



Eve Double PG-line



EV Charging Stations

Installation and User Manual





<b>1.</b>	<b>Safety and usage instructions</b>	<b>3</b>	5.5	Installation of the charging station	21
1.1	Disclaimer	3	5.6	Electrical installation	22
1.1.1	Disclaimer public charging stations	3			
1.2	Improper use	3	<b>6.</b>	<b>Commissioning</b>	<b>24</b>
1.3	Copyright	3	6.1	Safety instructions before use	24
1.4	Trademarks	3	6.2	Initial start-up	24
1.5	Languages	3	6.3	Testing the sockets	24
1.6	Purpose and intended audience	4	<b>7.</b>	<b>Connectivity</b>	<b>25</b>
1.7	Explanation of text instructions used	4	7.1	Configuring the charging station	25
1.7.1	Safety symbols	4	7.1.1	Wireless-connection	25
1.8	General safety	4	7.1.2	Wired network connection	25
1.9	Software and complementary documentation	4	7.1.3	Backoffice management systems	25
1.10	Operating conditions	5	7.2	Configuration tools	26
			7.2.1	Before using the MyEve app	26
			7.2.2	Before using the ACE Service Installer	26
<b>2.</b>	<b>Product overview</b>	<b>7</b>	<b>8.</b>	<b>Maintenance</b>	<b>27</b>
2.1	Exterior View Eve Double PG-line	7	8.1	Service	27
2.1.1	Valid for article numbers: 904462002, 904462003, 904462004, 904462005, 904462006, 904462007, 904462008, 904462009	7	<b>9.</b>	<b>Disposal</b>	<b>28</b>
2.2	Interior View Eve Double PG-line	9	9.1	Decommissioning and returning	28
2.2.1	Valid for article number: 904462002	9	9.2	Waste electrical and electronic equipment (WEEE)	28
2.2.2	Valid for article numbers: 904462003, 904462004, 904462005, 904462006, 904462007, 904462008, 904462009	10	<b>10.</b>	<b>Error codes and troubleshooting</b>	<b>29</b>
2.3	Identification label	11			
2.4	Surge Protection Device (SPD) Status Indicator	12			
<b>3.</b>	<b>User interface</b>	<b>13</b>			
3.1	Charging stations display during charging	13			
3.2	Status indicator symbols	13			
3.3	Access control for local authorization (charge cards)	13			
3.3.1	Installing the Master Key	14			
3.3.2	Removing the Master Key	14			
3.3.3	Adding and removing charge cards in the local database	14			
<b>4.</b>	<b>Operation</b>	<b>15</b>			
4.1	Payment options	15			
4.1.1	Starting and stopping the charging process with (mobile) bank card on the payment terminal	15			
4.1.2	Starting the charging process with QR code	15			
4.1.3	Finishing the charging process with QR code	17			
4.2	Start and stop charging with charge card	17			
<b>5.</b>	<b>Installing and Connecting</b>	<b>18</b>			
5.1	Safety announcements	18			
5.2	Scope of delivery	19			
5.3	Assembly and connecting prerequisites	20			
5.4	Mechanical installation	21			
5.4.1	Concrete base setup (option)	21			
5.4.2	Packaging removal	21			



## 1.1 Disclaimer

This document has been subjected to rigorous technical review before being published. It is revised at regular intervals, and any modifications and amendments are included in the subsequent issues. Although Alfen has made its best efforts to keep the document as precise and up-to-date as possible, Alfen does not assume any liability for defects and damage which results from the use of the information contained herein.

### NOTE

This manual is subject to updates and changes. Errors and omissions excepted.

Any deviation to the products as assembled by Alfen including, but not limited to, customer-specific modifications to the product such as the placement of stickers, SIM cards or the usage of different colors (all referred to as 'Customization') may affect the final product, its experience, appearance, quality and / or lifespan (the Customized Product). Alfen is not liable for any damage to, or caused by, the Customized Product if this damage is caused by this applied Customization.

Alfen shall not be liable in any way, for any kind of damage, and the (B2B) warranty for the product and the accessories shall not apply in the following cases:

- Failure to comply with the instructions in this manual in general and with the operating conditions specifically.
- Improper use.
- External damage.
- Installation, commissioning or faulty repair or maintenance by unqualified persons.
- Failures from the grid or the GPS / GPRS provider.
- Modification or configuration of the product or accessories without the knowledge of Alfen.
- Use of spare parts not approved or manufactured by Alfen.
- The charging station is used outside its operating conditions as stated in this manual.
- Situations have occurred that are beyond the control of Alfen(force majeure).
- Malfunction of an open charge point back office.
- Damage to the electrical vehicle.

### 1.1.1 Disclaimer public charging stations

Alfen ICU B.V. ("Alfen") has received the explicit request to use the open area in the Alfen Eve Double PG-line (the "EV Charger") for installing electrical components.

The indicated red marked area (the "Dedicated Area") in chapter Interior View Eve Double PG-line on page 9 may be used for the installation of electrical components within the Alfen Eve Double PG-line (the "charging station") which charging stations are placed in the public domain if the following conditions remain to be fulfilled throughout the Warranty Period:

- The charging station shall only be opened by authorized certified electricians who shall have completed the Alfen training (an "Engineer");
- Customer shall provide explicit consent to the Engineer for the placement of components in the Dedicated Area;
- The installation, the use and operation of the charging station (EV Charger) shall always be in accordance with all applicable laws, regulations and the manuals;
- Components may only be stored in the Dedicated Area before the main switch;
- All additional installed electrical components are IP20 at minimum and installed according local installation and safety regulations and laws.

If the above conditions remain fulfilled throughout the Warranty Period, Alfen confirms that the Dedicated Area may be used and the warranty for the charging station (EV Charger) remains valid.

## 1.2 Improper use

Using the charging station is safe when used as intended. Any other use or changes to the charging station are considered improper use and therefore not permitted. The operator, owner or qualified technician is responsible for any personal injury or material damage arising from improper use.

## 1.3 Copyright

The reproduction, distribution and utilization of this document, as well as the communication of its contents to other parties without explicit authorization by Alfen N.V. or one of its affiliates, is strictly prohibited. © Alfen N.V.

## 1.4 Trademarks

Eve®, ICU®, Alfen® are trademarks by Alfen N.V.. Any unauthorized use of the trademarks is therefore illegal.

## 1.5 Languages

The English version of this document is the original source. Documents in other languages are translations of this source.

# 1. SAFETY AND USAGE INSTRUCTIONS

## 1.6 Purpose and intended audience

This manual applies to the Eve Double PG-line (in this document also indicated as "charging station") produced by Alfen ICU B.V., Hefbrugweg 79, 1332 AM Almere, the Netherlands, reg. no. 64998363 ("Alfen"). The Alfen Eve Double PG-line is intended exclusively for charging electric vehicles and, when installed correctly, may be used by untrained individuals. Follow this manual to install and commission the charging station correctly.

Installation, commissioning and maintenance of this charging station may only be performed by a qualified electrician. It is essential that the qualified technician has:

- Expertise on all relevant general and specific rules regarding safety and incident prevention
- Comprehensive knowledge of applicable electrical regulations.
- The ability to identify risks and avoid potential hazards
- Received and read these installation and operation instructions

## 1.7 Explanation of text instructions used

Safety warnings and precautions are indicated in this document as follows:

### DANGER

Signal word used to indicate an imminently hazardous situation which, if not avoided, will result in death or serious injury.

### WARNING

Signal word used to indicate a potentially hazardous situation which, if not avoided, could result in death or serious injury

### CAUTION

Signal word used to indicate a potentially hazardous situation which, if not avoided, could result in minor or moderate injury.

### NOTE

Signal word used to provide additional information or information on possible product damage.

### 1.7.1 Safety symbols

The following warning pictograms are attached to (parts of) the charging station:

### Pictogram

### Description



Dangerous voltage



Protective earth

## 1.8 General safety

Follow the stated safety aspects when operating the charging station:

### DANGER

Risk of injuries, explosion or fire. Do not use the charging station in the vicinity of explosive or highly flammable substances.

### DANGER

Risk of electrocution. Do not use the charging station if it is partially submerged in water.

### DANGER

Risk of injury and electrocution. Do not use the charging station if it is damaged or plugs and cables are defective. Contact the charge point operator to repair the defects immediately.

### DANGER

Risk of injury and electrocution. Keep away children or individuals who are not able to assess the risks associated with using this product.

More extensive safety information is available in the relevant sections of this document.

## 1.9 Software and complementary documentation

### NOTE

You must have a wired network connection between the charging station and your laptop, tablet or smartphone to check whether a new firmware version is available.

- The MyEve app notifies if a new firmware version is available.
- The ACE Service Installer does not notify if a new firmware version is available. You need to check this via the menu "Device/Upload new firmware..."

# 1. SAFETY AND USAGE INSTRUCTIONS

## NOTE

It is possible to request a printed copy of this manual in your language by Alfen at any time. Refer to the contact information for your request.

By means of the following links you can obtain detailed information regarding the Eve Double PG-line charging stations.

YouTube channel



Alfen - Power to adapt

General information videos.

Data sheet



Datasheet - Eve Double PG-line

providing detailed information on models, technical features and equipment.

Knowledge Base



Knowledge Base

providing service and procedure instructions.

"Eichrecht Addendum"

For German market only



Handbuch Eve Eichrecht Addendum

Additional information document for the end user of the Eve Double PG-line with meters according to calibration regulations in Germany.

Firmware & Error code list



Firmware information and Error codes list

providing firmware information, update, error codes list.

Declaration of conformity



Declaration of Conformity Eve Double PG-line

Smart Charging configuration



Smart Charging Implementation Guide

Training for Alfen charging stations



Trainings charging stations equipment

class-room trainings provided by Alfen.

Warranty



B2B Warranty

The applicable Terms & Conditions of the Alfen B2B Warranty

## 1.10 Operating conditions

Operating temperature -25 °C to 40 °C

Relative atmospheric humidity 5 - 95%

Protection category I

Degree of protection (housing) IP54

IK protection (mechanical impact) IK10

Stand-by use Approx. 10 - 13 W

Environmental conditions For indoor use / For outdoor use

# 1. SAFETY AND USAGE INSTRUCTIONS

EN

---

Electromechanical environmental conditions	Residential environment (inland) Commercial and light industrial environment Industrial environment
--	---

---

Mechanical environmental conditions	Stationary equipment
-------------------------------------	----------------------

---

Access	Locations with restricted access Locations with non-restricted access
--------	--



### 2.1 Exterior View Eve Double PG-line

2.1.1 Valid for article numbers: 904462002, 904462003, 904462004, 904462005, 904462006, 904462007, 904462008, 904462009

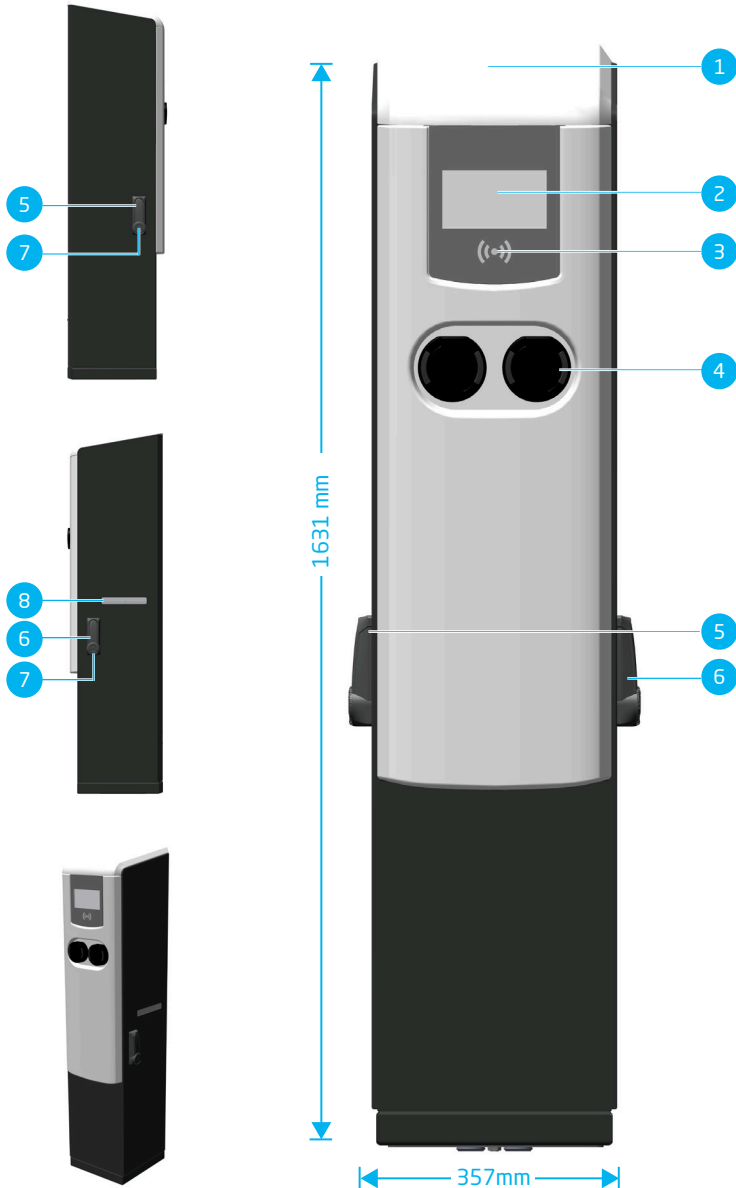

## 2. PRODUCT OVERVIEW

No.	Item
1	Top cover with lifting eye connection below
2	Color display
3	Charge card reader and authorization display
4	Type 2 plug connection with status LEDs, lockable

No.	Item
5	Lock power supply side
6	Lock Alfen side
7	Identification label
8	Window to read energy meter value

### 2.2 Interior View Eve Double PG-line

2.2.1 Valid for article number: 904462002

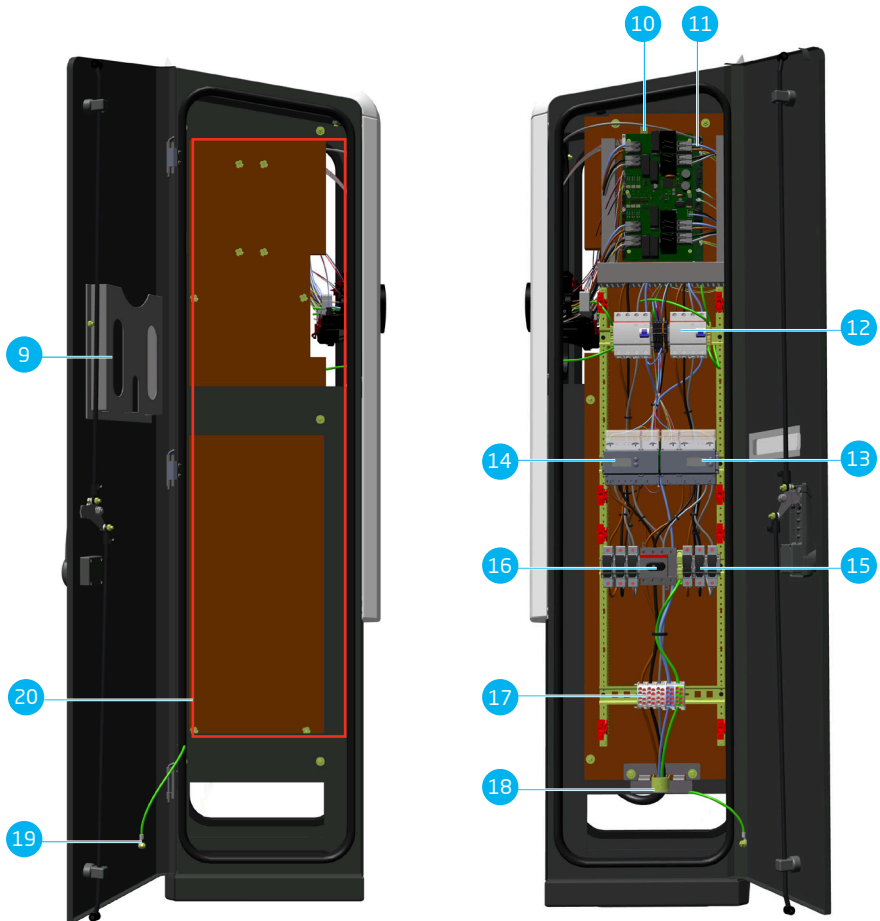

No.	Description
9	Document holder
10	SIM card holder
11	UTP (Ethernet) connector
12	Residual current device (RCD)
13	Left hand side energy meter, compliant with Measurement and calibration law (Eichrecht)
14	Right hand side energy meter, compliant with Measurement and calibration law (Eichrecht)
15	Cartridge fuses
16	Mains switch
17	Connection clamps
18	Strain relief

## 2. PRODUCT OVERVIEW

No. Description

19 Grounding cable

No. Description

20 Dedicated area (refer to extended warranty installation of electrical components in chapter "Disclaimer public charging stations on page 3")

2.2.2 Valid for article numbers: 904462003, 904462004, 904462005, 904462006, 904462007, 904462008, 904462009

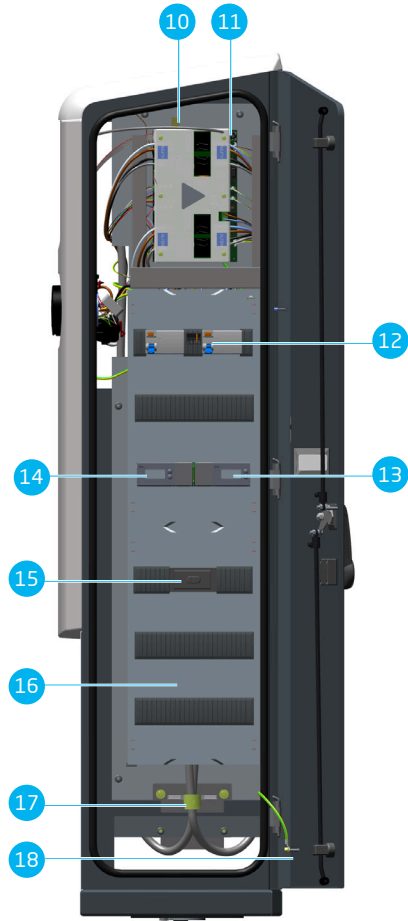
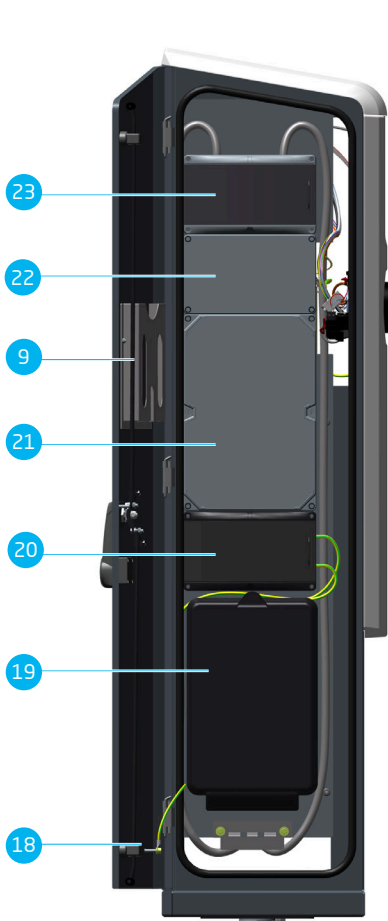

No. Item

9 Document holder

No. Item

10 SIM card holder

No.	Item
11	UTP (Ethernet) connector
12	Residual current device (RCD)
13	Left hand side energy meter compliant with Measurement and calibration law (Eichrecht)
14	Right hand side energy meter compliant with Measurement and calibration law (Eichrecht)
15	Mains switch
16	Connection clamps
17	Strain relief

No.	Item
18	Grounding cable
19	Grid connection box
20	Overvoltage protection
21	Space for domestic supply meter Single / Dual
22	Space for power meter connectivity equipment
23	Circuit breakers

### 2.3 Identification label

#### NOTE

When contacting your charge point supplier / operator, always have your type / article number and object number available to facilitate quick support.

The identification label shows the following information:

No.	Description
1	OCCP charge point model name (consisting of the platform name and the last five digits of the article number)
2	Type / Article number
3	Object number (unique number per charging station)
4	Production date
5	Technical specifications (such as the number of phases, maximum charging current and voltage)



## 2. PRODUCT OVERVIEW

### 2.4 Surge Protection Device (SPD) Status Indicator

On the Eve Double PG-line without grid connection box (article no. 904462002) over-voltage protection is provided by a Surge Protection Device (SPD).

The SPD limits the voltage supplied to the electrical devices to a certain threshold. This reduces damage to the charging station or equipment connected to it when an internal voltage peak occurs.

#### ! CAUTION

For the avoidance of misunderstanding and with reference to the Warranty, Alfen shall not be liable for any damage to a charging station or equipment connected thereto caused by an external power surge.

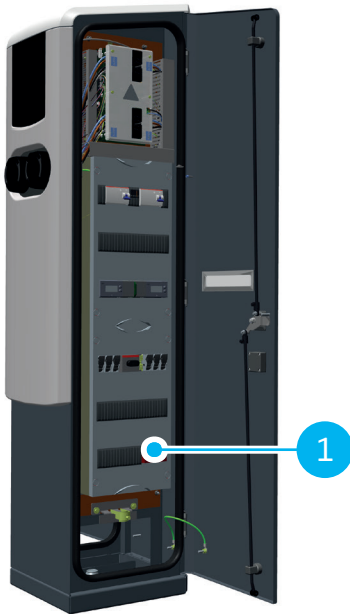

Figure 2.1: Location of the SPD inside the charging station

#### ! CAUTION

if an SPD has tripped it does no longer provide protection against over-voltage peaks.

The status is shown by the color of the inspection-indicator on the SPD. A green colored indicator means the SPD works normally. If the SPD has tripped, the indicator turns red.

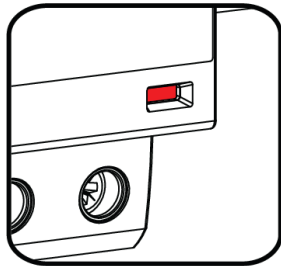
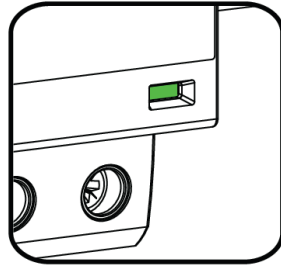

Figure 2.2: SPD Indicator

#### ! CAUTION

Visually inspect the SPD status indicator at least once a year, depending on grid quality and location of installation. Do this always in accordance with the SPD manufacturer's specifications.

No.	Item
1	Surge Protection Device

The state of the SPD can change over time. Excessive voltage peaks (such as by lightning or switching) can cause the SPD to trip.

## 3.1 Charging stations display during charging

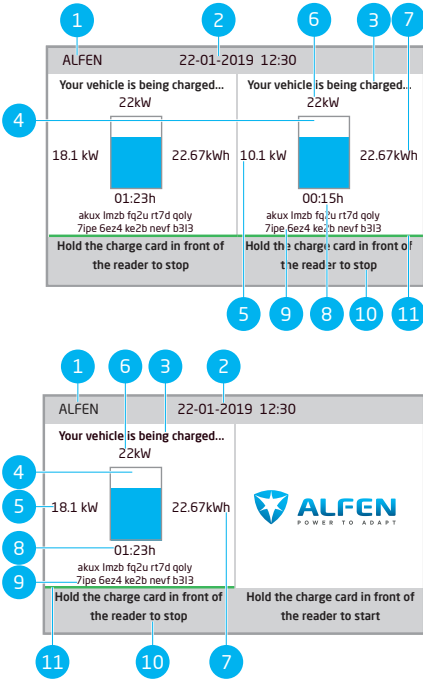

### No. Description

- Charge point ID:  
Identification is determined by the reseller or provider of the back-office management system. This ID can be shared, for example: if support is needed.
- Date and time:  
These are set automatically by a back-office management system or during installation, using the MyEve app or the ACE Service Installer. If the charging station does not have a current time, this field is invisible.
- Status information
- Status indicator (symbols)
- Current charging capacity to the connected vehicle
- Maximum charging capacity of the charge point

### No. Description

- Energy consumed during the current charging session
- Duration of the current charging session
- During a charging session the public key is shown on the display
- Usage instructions:  
In this field, instructions are displayed. If an error occurs, an error code and instruction will also be shown in this field.
- Progress bar:  
Displays the progress of the authorization process. A full progress bar indicates the background steps are completed and the charging session will start.

## 3.2 Status indicator symbols



Charge card accepted or cable connected



Warning. Notification with error code



Communicating with vehicle or charging complete



Error. Notification with error code



Charging session active, with charging speed indication



Progress bar

## 3.3 Access control for local authorization (charge cards)

To control local user access to an Alfen charging station, install a charge card as the 'Master key'. With this Master Key, you can grant access to other charge cards for using your charging station.

## 3. USER INTERFACE

### **NOTE**

Your charging station must be configured correctly in order to accept Master Keys.

#### 3.3.1 Installing the Master Key

1. Select a charge card, like the included Alfen charge card.
2. Hold the charge card in front of the card reader for 10 seconds.
3. After 10 seconds, the charge card will be registered as the Master Key. The following icon appears on the screen:



### **NOTE**

The charging station does not recognize the charge card and will give a warning first. Ignore the warning.

### **NOTE**

The charging station will only recognize one charge card as the Master Key.

Once the Master Key is registered, it can be used to add or remove charge cards from the local database.

#### 3.3.2 Removing the Master Key

A Master key can only be removed using the MyEve app or the ACE Service Installer. If necessary, you can ask for help from one of our technicians. This might, however, incur costs. Therefore, always keep the Master key in a safe location.

#### 3.3.3 Adding and removing charge cards in the local database

For every charge card held in front of the charging station, a sound signal will be given. Follow the on-screen instructions to manage access control:

### **NOTE**

The Master Key cannot be used for charging. It is only used for access control of the charging station.

1. Hold the Master key in front of the card reader



2. Hold the charge card you wish to add in front of the card reader. The following symbol is displayed:



3. Hold the charge card you wish to remove in front of the card reader. The following symbol is displayed.



4. To close the database, hold the Master Key again in front of the card reader.

### **NOTE**

If you have added or removed a charge card in error, you can immediately hold it in front of the card reader to undo the action.

### **NOTE**

To prevent the local database from being 'open' to access control, the menu will close automatically if no card has been detected or removed after 10 seconds. The symbol will disappear from the display.



## 4.1 Payment options

### 4.1.1 Starting and stopping the charging process with (mobile) bank card on the payment terminal

1. In order to authorize the payment,
  - present your (mobile) bank card to the card reader of the payment terminal.
2. Connect the charging cable to start the charging process. During charging the status indication on the charging station shows the progress. Charging will stop automatically when the battery has been charged completely.
3. When charging is completed or when you wish to stop the transaction:
  - present your (mobile) bank card to card reader of the payment terminal.
4. Unplug the charging cable.

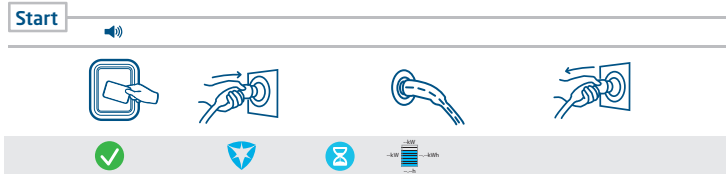





Figure 4.1: Customer Journey: Paying on payment terminal

### 4.1.2 Starting the charging process with QR code

The charging of the EV can be paid for by means of using a QR code. A smartphone (or similar device) is required, with a connection to the Internet and a camera to scan QR codes. Follow the steps described in the table below.

Where	Steps
 on the charging station	 The charging station shows a QR code.
	 Scan the QR code with a mobile device.
	 The mobile device decodes the QR code and opens a web page of the Charge Point Operator.

# 4. OPERATION

Where

Steps



The web page shows a form that asks for an email address. Enter the correct email address.

**NOTE**

The email address is necessary for delivering an invoice for the costs of the charging session.

on the web page of the Charge Point Operator



After the email address is accepted, the web page shows the available payment providers that can handle the payment. Select the preferred payment provider.



The mobile device opens the web page of the selected payment provider, typically a bank or an Internet payment service.

**NOTE**

The exact contents of this page depends on which payment provider has been selected.



Authorize the payment. This may require a password or a different means of confirming your identity, depending on which payment provider has been selected. This information is only communicated with the payment.



The authorization is checked and the web page of the Charge Point Operator shows that it is accepted. A start activation is sent to the charging station.



The charging station starts the charging process. It displays a green check mark and shows a message to insert the charging cable.

on the charging station









Insert the charging cable in the charging station and in the EV.



The charging process starts. The display of the charging station shows the details.

### 4.1.3 Finishing the charging process with QR code

Where	Steps
	 <p>Disconnect the charging cable from the vehicle. This stops the charging process.</p>
on the charging station	 <p>The charging station unlocks the charging cable.</p>
	 <p>The charging station shows a summary of the transaction and prompts to remove the charging cable from the charging station.</p>
	  <p>Remove the charging cable from the charging station.</p>
	 <p>The payment service provider settles the costs of the transaction. An invoice specifying these costs is sent to the email address that was specified earlier.</p>

### 4.2 Start and stop charging with charge card

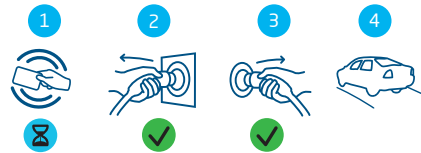
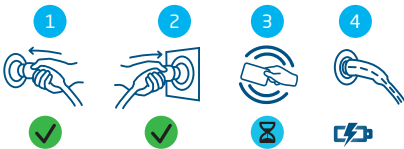

No.	Description
1	Plug the charging cable into the car
2	Plug the charging cable into the charge point
3	Scan the charge card on the charging stations card interface
4	Charging in progress

No.	Description
1	Scan the charge card on the charging stations card interface
2	Remove the charging cable from the charge point
3	Remove the charging cable from the car
4	Leave the charging place

# 5. INSTALLING AND CONNECTING

## 5.1 Safety announcements

### DANGER

Risk of injury and electrocution. Installation, (de)commissioning and maintenance of the charging station may only be performed by a qualified electrician.

### DANGER

Risk of injury and electrocution. Installing the charging station incorrectly may result in fatal injury! When working with electricity, failure to comply with relevant regulations can lead to dangerous and life-threatening situations.

### DANGER

Risk of electrocution. The electrical system must be disconnected from every power source before performing any installation or maintenance work!

### DANGER

Risk of injury and electrocution. The charging station contains electrical components that still contain a charge after being disconnected from the system. Always test with proper equipment there's no residual current before commencing to work.

### WARNING

Risk of injuries, explosion or fire. Never install in a potentially explosive atmosphere.

### WARNING

Risk of electrocution. Never install in areas prone to flooding without implementing compensatory measures.

### WARNING

Risk of injury and electrocution. Installation work may not be carried out during rain or if the air humidity exceeds 95%.

### WARNING

Risk of injury and electrocution. The installation must be performed by a qualified electrician who has read this manual and will execute the installation in accordance with the IEC 60364 (Electrical Installations for Buildings) standard.

### WARNING

Risk of damage or electrocution. A charging station must always be installed on separate power circuit.

### WARNING

Risk of damage or electrocution. Local conditions may affect the installation requirements. Your installation must comply with the standards and regulations of the location (country) where it is installed.

### CAUTION

Risk of injury and damage. The installer is always responsible for choosing the correct cable diameter and complying with the relevant standards and legislation.

### CAUTION

Risk of injury and damage. The installation and cables should be installed to match the maximum charging current to the input of the charging station. This should assume continuous load.

### CAUTION

Risk of injury and damage. Mechanical impact and/or collisions might cause damage to the equipment. Protect Alfen products installed in public areas and car park sites.

### CAUTION

Risk of damage. Adapters or conversion adapters are not allowed to be used.

## 5.2 Scope of delivery

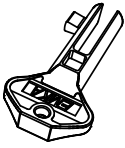

1



2



3

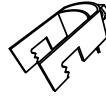

4

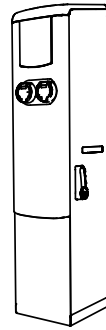

9



5



6

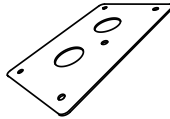

7

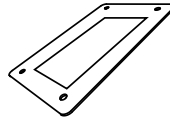

8

No.	Item	Quantity
1	Pin Lock Key	1
2	Gland M12 x 1.5	1
3	Union nut M12 x 1.5	1
4	Strain relief K24U	1
5	Lifting eyes	2

No.	Item	Quantity
6	Grommet 30 - 45 mm	2
7	Base plate	1
8	Gasket	1
9	Charging station	1

## 5. INSTALLING AND CONNECTING

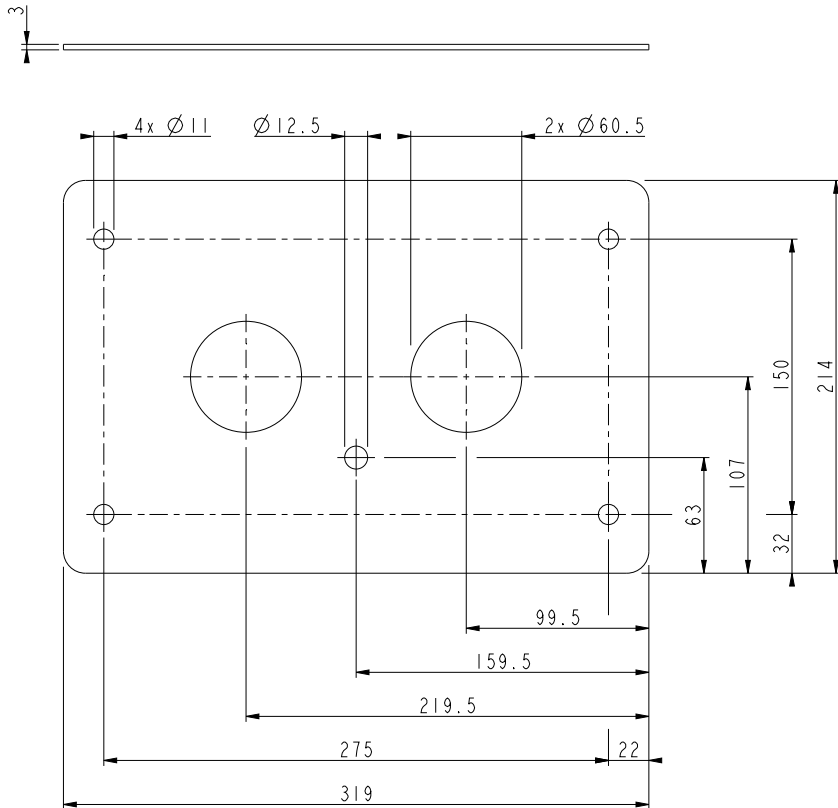

Figure 5.1: Detailed view of base plate

### 5.3 Assembly and connecting prerequisites

Make sure that the requirements for the installation of the charging station are met:

- The cable routing from the main distribution board to the charging station must be protected against short circuits and overcurrent.
  - A circuit breaker characteristic B or C (or according to local standards and laws).
  - Fusing cartridges type gG (or according to local standards and laws).

The charging stations with grid connection box do not need pre-protection.

- The cable routing and the charging station are part of a TN-S system; the device must be earthed via the main distribution board.

- The cable routing must be installed according to the usual professional standards applicable on site.

When selecting the installation location, you must consider the following:

- Never install in a potentially explosive atmosphere.
- Never install in areas prone to flooding, without resorting to additional measures.
- Fully comply with local technical requirements and safety regulations.
- The installation site must have a flat and solid base.
- The ambient temperature must be in a range of -25 °C and 40 °C.
- The temperature differences in 24 hours must not exceed a maximum of 35 °C.

## 5. INSTALLING AND CONNECTING

- Select the location of the charging station in such way that the charging cable (approximately 5 m) can be used without stretching it and thus causing tension.
- Prevent persons from driving over the cable.
- Prevent pedestrians from tripping over the cable.

### 5.4 Mechanical installation

Use the following tools and materials to install the charging station:

- Spirit level
- Phillips screwdriver
- Screwdriver for the terminal block
- Wire stripper
- Carpet knife

For installation on a concrete base (option), the following supplied parts are supplied:

- 4 x M10 x 30 mm RVS compression fitting with threaded end
- 4 x M10 RVS nut
- 4 x M10 RVS rings
- Shovel (not supplied)

#### 5.4.1 Concrete base setup (option)

##### **NOTE**

Due to the size of the concrete base, you must dig a hole that is approximately 600 mm deep.

##### **CAUTION**

Make sure you dig in a safe place. There is a risk that you may dig into underlying power cables. Proceed carefully.

1. Dig a hole of about 500 x 500 mm with a depth of 650 mm.
2. Place the concrete base in this hole.
3. Refill the hole with sand and stamp down any loose soil.
4. Position the earth electrode or use the TT system.
5. Place the grommets in the base plate and cut them to the desired size to allow the power cable and the grounding electrode to be run through them.
6. Feed the power cord and earth electrode through the pipe collar (not included), concrete base (option) and grommets into the base plate.

##### **NOTE**

Please refer to the specifications in the data sheet for the appropriate cable diameters.

7. Put the base plate on the base and place the gasket on the base plate.
8. The power cable must have an excess length of at least 250 mm (measured from the ground).

##### **NOTE**

Due to the installation of the strain relief, it is advisable not to cut the cable beforehand.

#### 5.4.2 Packaging removal

1. Loosen the screws from the packaging of the charging station and remove the packaging.
2. Remove the roof of the charging station.
3. Screw in the two lifting eyes provided into the corresponding holes at the top of the charging station.
4. Pass a lifting sling through the lifting eyes and carefully lift the charging station off the pallet.
5. Lower the charging station onto the concrete base or over the wire ends supplied onto the firm base.



#### 5.5 Installation of the charging station

1. Open both doors of the charging station with the supplied pin lock key and insert the four thread ends through the hole of the charging station into the concrete base.
2. Slide the supplied M10 rings over the thread ends, place the washers over the bolts and place them in the screw holes in the base. Tighten all M10 bolts with a tightening torque of 13 Nm.
3. Remove the lifting eyes.
4. Replace the top of the charging station and secure it with the supplied bolts and nylon washers.

## 5. INSTALLING AND CONNECTING

5. Remove the supply cable covering with a carpet knife and remove the sheathing of the separate wires with wire strippers.

### **WARNING**

Always attach the earth conductor first!

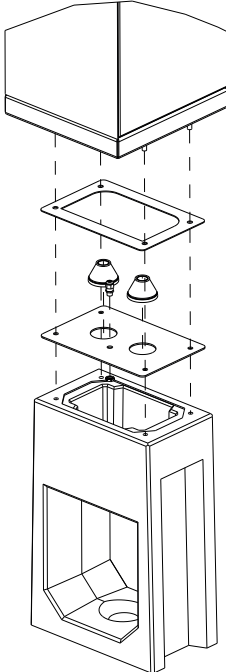

### 5.6 Electrical installation

1. The charging station must be earthed. Connect the earth electrode first. An earth connection is installed in the sub-distribution board; the earth electrode can be connected to it.
2. The grid operator's earth electrode may only be used for earthing after obtaining its prior written permission.
3. The earth electrode resistance must be below 100 ohms.
4. For products without grid connection box unit: Switch off the main protection in the installation
5. For products equipped with a grid connection box unit: remove the fusing cartridges from the sub-distributor
6. Connect the phase wires to the fusing cartridge holders in the sub-distributor.
7. A PUK strain relief is included in the scope of delivery.

8. In the case of charging stations supplied with a grid connection box, insert the fusing cartridges into the holders and close the holders.
9. Make sure that the power switch and the RCD switches are switched on.
10. Both door locks of the charging station can hold two cylinders. For example, place a cylinder of the grid operator and a customer cylinder on both sides (Alfen and energy provider side). See illustration.
11. Close the door and the lock and make sure that it is properly locked.



Figure 5.2: Example of a PUK strain relief

### **NOTE**

Make sure that the cables are not jammed in the door when closing the door

### **NOTE**

If no cylinders are installed, the door can be opened by unauthorized persons. Always install two cylinders in both doors.





## 5. INSTALLING AND CONNECTING

Space for two cylinders (Locking cylinder operator side: half cylinder 30/10 mm)

---

### **DANGER**

There must be absolutely no gaps between individual housing parts. This is harmful to the moisture and dust protection and affects the life cycle of your charging station

---

# 6. COMMISSIONING

## 6.1 Safety instructions before use

Carry out the following safety instructions before commissioning your charging station:

1. Check if the charging station is properly connected to the power supply as described in this manual.
2. Check if the distribution of the power supply is separately protected by an appropriate breaker (automatic or fuse cartridges).
3. Check if the charging station is installed in accordance with this manual.
4. Check if the casing is closed.
5. Measure the isolation resistance to verify that the charging cable is not twisted and that the cable, plug and casing are not damaged.

## 6.2 Initial start-up

1. Turn on the local power supply.

The charging station will run self diagnostics. It runs through the following steps during this process:

- The display will illuminate briefly and then turn off.
- Testing locks
- Testing internal relays; you will hear these click
- The display will illuminate briefly.

The charging station will display the following:

- The display will show the message 'Charging point is powering up' and then the start screen with logo.

Your charging station is now ready for testing.

## 6.3 Testing the sockets

1. Put the test charging cable or charging cable into the socket. Press firmly.
2. Hold the charge card in front of the card reader to start charging.
  - a. If you use a charging cable the texts 'Card accepted' and 'Charging in progress' are shown.
  - b. If you use a test charging cable 'Please plug cable into vehicle' is displayed. An electrical load needs to be connected to simulate the charging process, then the texts 'Card accepted' and 'Charging in progress' are shown.

The socket is functional.

3. Hold the charge card in front of the card reader to stop charging.

The text 'End of session' is displayed.

4. Pull out the test charging cable or charging cable.

The socket is now ready for use.

5. Repeat the same procedure for the other socket.

## 7.1 Configuring the charging station

### 7.1.1 Wireless-connection

How to establish a wireless (WiFi) connection between your device and the charging station:

#### NOTE

Currently the communication between the app and the charging station is only possible via a wired connection.

1. Download the MyEve app on your device. The device can be a smartphone, tablet or laptop.
2. Create an account in the MyEve app and login.
3. Find your newly installed charging station in the list of newly discovered devices.

#### NOTE

Bluetooth must be enabled on your mobile device.

4. Choose one of the options to connect your device:
  - a. connect with the MyEve app directly to the WiFi network of the charging station or
  - b. connect with the MyEve app to the same local area network (LAN) the charging station is connected to.
5. Enter the provided password.  
The network connection has now been established. Via the MyEve app you can configure the settings
6. After finishing the configuration, hand over the card with password (recovery) information to the customer.

### 7.1.2 Wired network connection

How to establish a wired network connection by connecting the charging station to your device using an UTP (Ethernet) cable:

The minimum requirement is a CAT5 UTP (Ethernet) cable

#### NOTE

For the use of a smartphone or tablet an adapter such as a USB-C to Ethernet or Lightning to Ethernet is required.

1. Log into the MyEve app or the ACE Service Installer.
2. Connect the UTP (Ethernet) cable to your router or directly to the charging station.

3. Connect the UTP (Ethernet) cable with the corresponding port.
4. Connect your device to the switch or router or directly to the charging station.
5. Select your charging station from the list in the MyEve app or the ACE Service Installer.

#### NOTE

If the charging station(s) is (are) not detected automatically, the MyEve app or the ACE Service Installer might be blocked by the Firewall on your laptop, tablet or smartphone. Check the settings of your laptop, tablet or smartphone and try again.

6. Enter the provided password.  
The network connection has now been established. Via the MyEve app or the ACE Service Installer you can configure the settings
7. After finishing the configuration, hand over the card with password (recovery) information to the customer.

### 7.1.3 Backoffice management systems

If additional services by a backoffice provider have been purchased, the charging station has been configured ex-factory to connect to the selected backoffice management system.

#### NOTE

A connection with a backoffice management system can only be established if arrangements with the supplier of this system have been made. The service of third parties is not provided by Alfen.

#### NOTE

If the charging station is set to connect with a backoffice management system, it will do so directly and automatically.

#### NOTE

Manually configuring and connecting to a backoffice management system can be done with the MyEve app. A SIM card needs to be installed during installation. If you do not have a SIM card, please contact your backoffice provider.

# 7. CONNECTIVITY

## **NOTE**

If a mobile communication (SIM card) Internet connection has been purchased, the charging station is already equipped with a SIM card and will automatically connect, once the charging station is being commissioned.

### 7.2 Configuration tools

The charging station can be accessed and configured:

- via the MyEve app
- via the ACE Service Installer

The app will guide you step-by-step through the configuration process.

## **NOTE**

Currently the communication between the MyEve app and the charging station is only possible via a wired connection.

#### 7.2.1 Before using the MyEve app

## **NOTE**

The MyEve app is designed to be used exclusively by the installer / electrician. Its purpose is to commission and configure Alfen charging stations.

The MyEve app is not intended for end users of the charging station.

1. Download the MyEve app in Google Play, Apple Store or Windows Store to your laptop, tablet or smartphone.



Google Play Store



Apple App Store



Microsoft Store

2. You will be requested to create an account.
3. If you have the MyEve app installed, make sure you update to the latest version. Use the above QR-codes to see if your MyEve app needs to be updated.
4. Make sure the Firewall settings on your laptop, tablet or smartphone are not blocking the MyEve app.

#### 7.2.2 Before using the ACE Service Installer

1. Download the ACE Service Installer from the Alfen website to your laptop:

<https://alfen.com/en-gb/search-downloads>

2. Request an account at this e-mail address: [ace.aftersales@alfen.com](mailto:ace.aftersales@alfen.com).

## **NOTE**

It may take some days until you receive the login-data.

3. If you have the ACE Service Installer installed, make sure you have the latest version. If updates are available, you will be asked to update when you log in.
4. Make sure the firewall settings on your device are not blocking the ACE Service Installer.

### 8.1 Service

The Eve Double PG-line charging stations are serviced by the local charge point supplier. Your charge point supplier provides support to you. When contacting your charge point supplier, always have the serial number of your charging station available to facilitate quick support. Optionally you can find support for all our products on [knowledge.alfen.com](https://knowledge.alfen.com).

# 9. DISPOSAL

## 9.1 Decommissioning and returning

### **WARNING**

Risk of injury and electrocution. Installation, (de)commissioning and maintenance of the charging station may only be performed by a qualified electrician.

For returning charging equipment to Alfen, create a 'Request for Service' ticket at [support.alfen.com](https://support.alfen.com).

For further instructions please view How do I return a charging station to have it repaired? You will receive all shipping instructions within the ticket.

## 9.2 Waste electrical and electronic equipment (WEEE)









Electrical and electronic equipment contains materials, components and substances that may be hazardous and present a risk to human health and the environment if not handled correctly.

Equipment marked with the illustrated crossed out wheeled bin is electrical and electronic equipment. The crossed out wheeled bin indicates that this waste must be collected separately and must not be discarded together with household waste.





Refer to your local authority for collection schemes under which residents can dispose waste electrical and electronic equipment at a recycling center or other collection points.

# 10. ERROR CODES AND TROUBLESHOOTING

Code	Error message displayed	Icon	Possible cause	Possible countermeasures
General error				
001	Not able to charge. Please call for support.		Unknown general error.	Contact the service department of your charge point supplier.
Charging station related error				
101	One moment please. Your charging session will resume shortly.		DC fault current (>6mA) detected by charging station.	<ul style="list-style-type: none"> <li>One specific vehicle: Contact your car dealership.</li> <li>Multiple vehicles: Contact the service department of your charge point supplier.</li> </ul>
102	Not able to charge. Please call for support.		Internal error. Unexpected or no voltage on output of power board.	<ul style="list-style-type: none"> <li>Contact the service department of your charge point supplier.</li> <li>Check powerboard.</li> </ul>
104	Not able to charge. Please call for support.		Internal error. Voltage to low on internal power supply (power board).	<ul style="list-style-type: none"> <li>Contact the service department of your charge point supplier.</li> <li>Check powerboard.</li> </ul>
105	Not able to charge. Please call for support.		Internal error. No communication with internal power meter.	<ul style="list-style-type: none"> <li>Contact the service department of your charge point supplier.</li> <li>Check if internal power meter is configured correctly.</li> <li>Check internal power meter.</li> </ul>
106	Not able to charge. Please call for support.		Power interrupted by internal RCD.	<ul style="list-style-type: none"> <li>Contact your installation engineer.</li> <li>Internal RCD (Type A: 30 mA AC) tripped.</li> </ul>
108	Not displayed.	Not displayed.	Charging station configured as Plug & Charge authorization mode and Plug & Charge ID is not configured.	<ul style="list-style-type: none"> <li>Contact the service department of your charge point supplier.</li> <li>Configure Plug &amp; Charge ID.</li> </ul>
109	Not displayed.	Not displayed.	No connection / connection lost to card reader.	<ul style="list-style-type: none"> <li>Contact the service department of your charge point supplier.</li> <li>Check if the card reader is connected correctly.</li> </ul>

## Installation related error







# 10. ERROR CODES AND TROUBLESHOOTING

Code	Error message displayed	Icon	Possible cause	Possible countermeasures
201	Error in installation. Please check installation or call for support.		Protective earth not connected or unstable.	<ul style="list-style-type: none"> <li>Contact your installation engineer.</li> <li>Recommended earth resistance of the installation &lt; 100 Ohm.</li> </ul>
202	Input voltage too low, not able to charge. Please call your installer.		Supply voltage below 210 VAC.	Contact your installation engineer.
206	Temporary set to unavailable. Contact CPO or try again later.		Charging station is set to inoperative by the charge point operator / the charging station is updating.	<ul style="list-style-type: none"> <li>Contact your charge point operator.</li> <li>Firmware update in progress.</li> </ul>
208	Not displayed.	Not displayed.	Supply voltage above 275 VAC.	<ul style="list-style-type: none"> <li>Contact the service department of your charge point supplier.</li> <li>Check voltage levels.</li> </ul>
209	Not displayed.	Not displayed.	No connection / connection lost to DSMR4.x / SMR5.0 (P1) smart energy Meter.	<ul style="list-style-type: none"> <li>Contact the service department of your charge point supplier.</li> <li>Check DSMR4.x / SMR5.0 (P1) smart energy Meter connection.</li> </ul>
210	Not displayed.	Not displayed	No connection / connection lost to Modbus TCP/IP energy meter / energy management system.	<ul style="list-style-type: none"> <li>Contact the service department of your charge point supplier.</li> <li>Check Modbus TCP/IP energy meter / energy management system.</li> </ul>
211	Not able to lock cable. Please call for support.		Unable to move locking motor during build-in self-test.	<ul style="list-style-type: none"> <li>Contact your installation engineer.</li> <li>Check if locking motor is connected correctly.</li> <li>Check if locking motor can move.</li> </ul>
212	Error in installation. Please check installation or call for support.		Missing phase in installation.	<ul style="list-style-type: none"> <li>Contact your installation engineer.</li> <li>Check voltage levels.</li> </ul>
213	Not displayed.	Not displayed.	No connection / connection lost to TIC smart energy Meter.	<ul style="list-style-type: none"> <li>Contact the service department of your charge point supplier.</li> <li>Check TIC smart energy Meter connection.</li> </ul>



Vehicle related error



## 10. ERROR CODES AND TROUBLESHOOTING

Code	Error message displayed	Icon	Possible cause	Possible countermeasures
301	One moment please your charging session will resume shortly.		Unknown error in communication with car.	<ul style="list-style-type: none"> <li>• Check car and charging cable.</li> <li>• Otherwise contact the service department of your charge point supplier.</li> </ul>
302	One moment please your charging session will resume shortly.		Safety measure, Vehicle draws more power than allowed / did not reduce power in time according to the IEC 61851 standard.	<ul style="list-style-type: none"> <li>• One specific vehicle: Contact your car dealership.</li> <li>• All vehicles: Contact the service department of your charge point supplier.</li> </ul>
303	One moment please your charging session will resume shortly.		Safety measure, vehicle has started and stopped charging to often within 1 minute.	<ul style="list-style-type: none"> <li>• Check car and charging cable.</li> <li>• Otherwise contact the service department of your charge point supplier.</li> </ul>
304	Charging not started yet to continue please reconnect cable.		Cable connected for more than 2 minutes without starting a charging session.	<ul style="list-style-type: none"> <li>• Reconnect cable and start charging session within 2 minutes.</li> <li>• Otherwise contact the service department of your charge point supplier.</li> </ul>
Ambient or equipment related error (user, plug, cable, weather conditions etc.)				
401	Inside temperature high. Charging will resume shortly.		Temperature inside the charge point above 70 degrees Celsius.	<p>Unexpected:</p> <ul style="list-style-type: none"> <li>• Ambient temperature.</li> <li>• No EV charging.</li> </ul> <p>Contact the service department of your charge point supplier.</p> <p>Expected:</p> <ul style="list-style-type: none"> <li>• Ambient temperature.</li> <li>• Installed in direct sunlight.</li> <li>• EV charging.</li> </ul> <p>Contact your installation engineer.</p>
402	Inside temperature low. Charging will resume shortly.		Temperature inside the charge point below -40 degrees Celsius.	<ul style="list-style-type: none"> <li>• Unexpected ambient temperature.</li> </ul> <p>Contact the service department of your charge point supplier.</p> <ul style="list-style-type: none"> <li>• Expected ambient temperature.</li> </ul>
404	Not able to lock cable. Please reconnect cable.		Unable to lock the charging cable.	<p>Contact the service department of your charge point supplier.</p> <ul style="list-style-type: none"> <li>• Check socket and charging cable plug.</li> <li>• Check if the lock motor can move freely.</li> </ul>

# 10. ERROR CODES AND TROUBLESHOOTING

Code	Error message displayed	Icon	Possible cause	Possible countermeasures
405	Cable not supported. Please try connecting your cable again.		Measure PP resistance of the charging cable is out of range according to the IEC 61851 standard.	<ul style="list-style-type: none"><li>• One specific cable: Issues with other charge points.</li></ul> Cable broken <ul style="list-style-type: none"><li>• All cables: No issue with other charge point.</li></ul> Contact the service department of your charge point supplier.
406	No communication with vehicle. Please check your charging cable.		Monitored CP voltage level is out of range according to the IEC 61851 standard.	<ul style="list-style-type: none"><li>• One specific cable: Issues with other charge points.</li></ul> Cable broken <ul style="list-style-type: none"><li>• All cables: No issue with other charge point.</li></ul> Contact the service department of your charge point supplier.
407	Not displayed.	Not displayed.		

# Contact

---

## Alfen ICU B.V.

Hefbrugweg 79  
1332 AM Almere  
The Netherlands

P.O. box 1042  
1300 BA Almere  
The Netherlands

Alfen Knowledge Base:	<a href="https://knowledge.alfen.com">knowledge.alfen.com</a>
Alfen Service Portal:	<a href="https://aftersales.alfen.com">aftersales.alfen.com</a>
Tel. Service:	+31 (0)36 54 93 402
Website:	<a href="https://alfen.com">alfen.com</a>