

Emma®





EN

P. 4

DE

P. 8

SE

P. 12

DK

P. 16



## DREAM-TIME IS HERE!

Your Emma Boxspring Bed is reality now and you are in for a great night of sleep!



### 7 REASONS YOU MADE THE RIGHT CHOICE:

1. Designed with carefully selected, durable, long-wearing materials.
2. Perfect height so that you can get in and out of bed easily.
3. Sturdy Wooden Feet which ensure great stability.
4. The Bonell-spring base makes it highly ergonomic.
5. Lean back and relax with our extra padded headboard.
6. Our 7-zone pocket spring mattress ensures your shoulders and hips are perfectly supported.
7. The optional Emma Flip Topper adds an extra layer of comfort.



## OUR RECOMMENDATION FOR THE PERFECT REST:



Clean your cover every six months.  
It is easily removeable and machine washable (40 °C).



Take time for yourself and enjoy a  
good book before going to sleep.



Try both sides of the topper and find  
your preferred firmness.



## HOW TO ASSEMBLE YOUR EMMA BOXSPRING BED

1

Align the left and right bed base so that the slider to attach the headboard is on the same side.

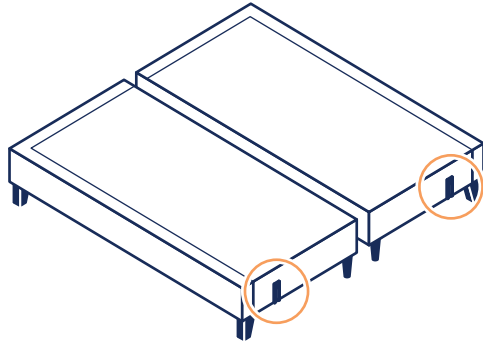

2

Attach the four wooden feet to the visible corners of the bed.

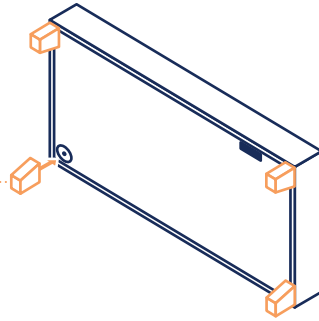

3

Place both Velcros close to where the middle feet would be screwed in. Once the feet have been inserted, the box spring can be firmly attached to each other.

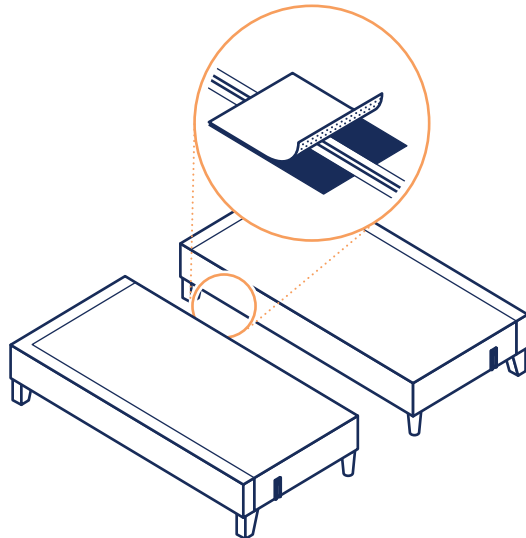

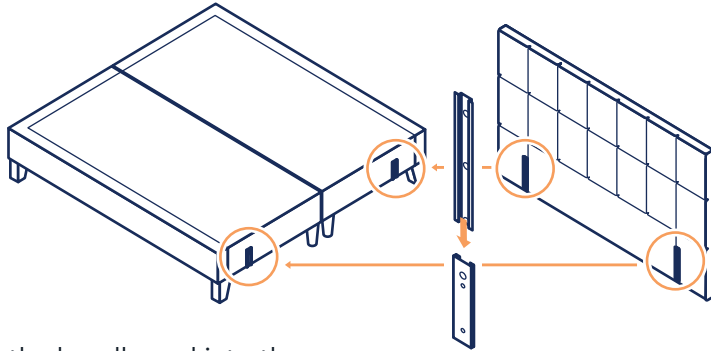

4

Push the headboard into the slider on the front of the bed until the headboard touches the floor.

5

Open the zipper of the cover to place the mattress inside of it. Close the zipper with the washable white fabric on the top.

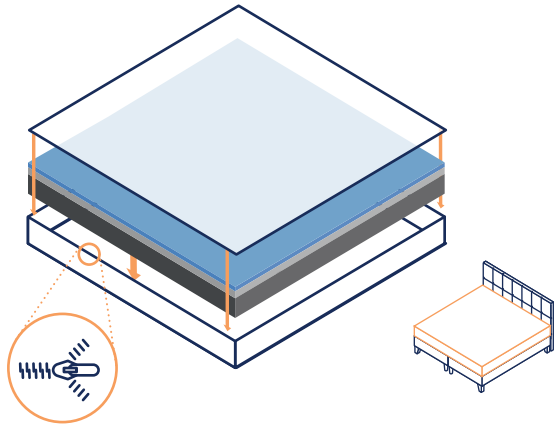

6

Finally, if you added a topper to your Boxspring Bed, place the topper on top.

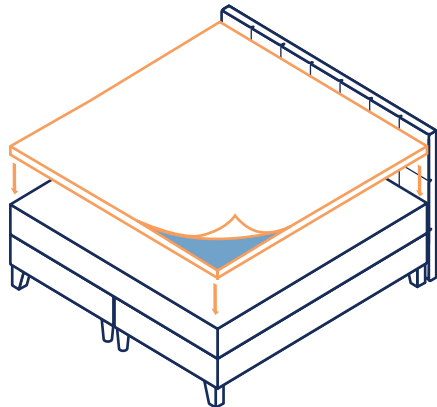

**Happy dreams!**  
**Your Emma Team**



## AUFWACHEN!

Dein Emma Boxspring-Bett ist jetzt Realität und Du kannst Dich auf erholsame Nächte freuen!



## 7 GRÜNDE, WARUM DU DIE RICHTIGE WAHL GETROFFEN HAST:



1. Sorgfältig ausgewählte Materialien für eine lange Lebensdauer.
2. Extra Komfort Höhe, um entspannt aus und ins Bett zu steigen.
3. Füße aus hochwertiger Holz geben Deinem Bett hervorragende Stabilität.
4. Bonell-Federkern für eine verbesserte Ergonomie.
5. Dein extra gepolstertes Kopfteil zum Anlehnen und Entspannen.
6. 7-Zonen-Taschenfederkern-Matratze für ultimative Unterstützung die ganze Nacht lang.
7. Der Emma Flip Topper sorgt für die Extraportion Komfort.



## UNSERE EMPFEHLUNG FÜR GUTEN SCHLAF:



Reinige Deinen Bezug alle sechs Monate.  
Er ist leicht abnehmbar und in der Maschine waschbar (40 °C).



Nimm Dir Zeit für Dich und genieße  
ein gutes Buch vor dem Schlafengehen.



Wende Deinen Topper  
alle drei Monate.



## AUFBAU ANLEITUNG EMMA BOXSPRINGBETT

1

Richte die linke und rechte Bettbasis so aus, dass sich die Halterungen für die Befestigung des Kopfteils an der selben Seite befinden.

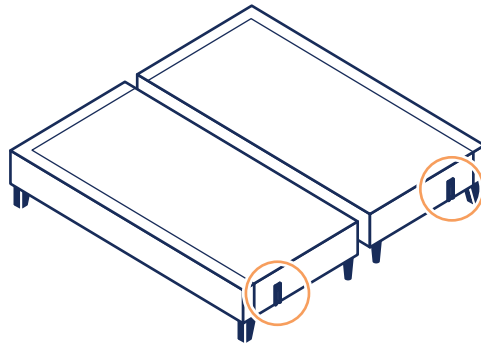

2

Befestige die vier Holzfüße an den sichtbaren Ecken der Bettgestelle.

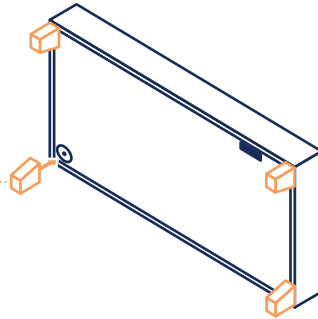

3

Platziere die Klettverschlüsse pro Bettbasis an der Stelle, wo die Mittelfüße eingeschraubt werden. Sind die Füße einmal eingeschraubt, können die beiden Bettteile aneinander fixiert werden.

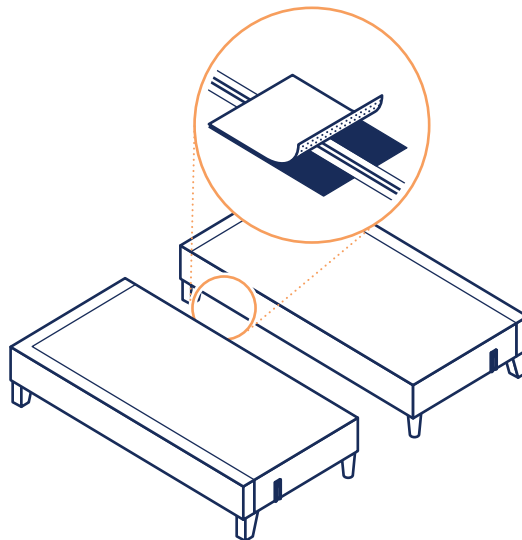

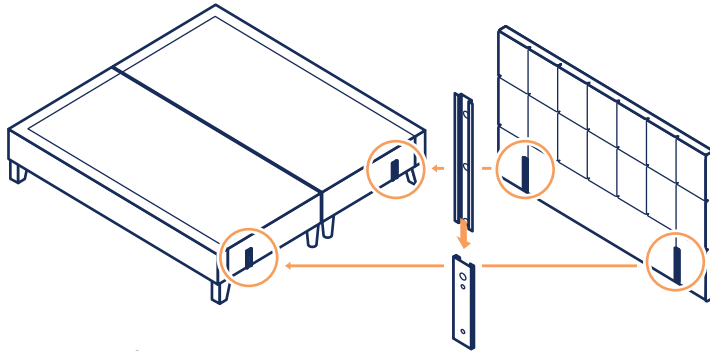

4

Schiebe das Kopfteil nun vorne in die Halterungen, bis das Kopfteil den Boden berührt.

5

Öffne nun den Reisverschluss des Bezuges, um die Matratze hineinzulegen. Schließe daraufhin den Bezug mit dem oberen weißen waschbaren Teil.

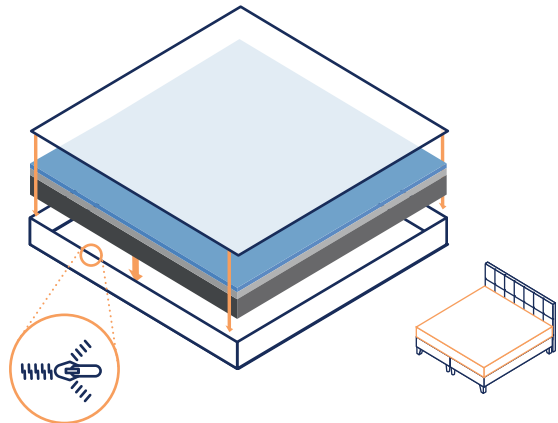

6

Lege den Topper auf die Matratze.

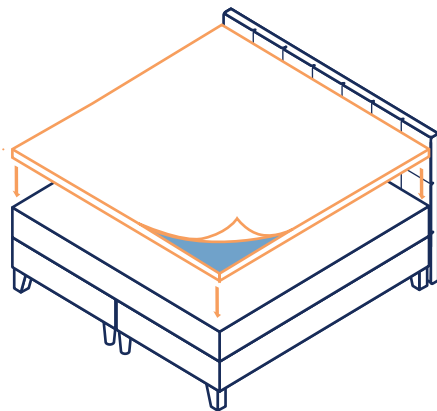

**Dein Tag**  
**Powered by Emma**



## NU ÄR DRÖMMEN HÄR!

Din Emma Boxspring-säng är nu en verklighet och tiden är inne för en god natts sömn.



### 7 SKÄL TILL ATT DU GJORDE ETT BRA VAL:



1. Noggrant utvalda material för lång hållbarhet.
2. En sänghöjd som skapar extra komfort och som gör det enkelt att ta sig i och ur sängen.
3. Sängben i trä för att ge din säng bra stabilitet.
4. Bonnellfjäderbasen för förbättrad ergonomi.
5. Vår extra vadderade huvudgavel som är skön att luta sig mot.
6. 7-zons fjädermadrass som ger dig maximalt stöd under hela natten.
7. Emma bäddmadrassen ger dig extra komfort.

## VÅR REKOMMENDATION FÖR DEN PERFEKTA SÖMNERN:



Tvätta bäddmadrassens  
fodral i maskinen var sjätte månad (40 °C).



Ta tid för dig själv och njut av  
en bra bok innan du blundar för natten.



Vänd bäddmadrassen  
var tredje månad.



## HUR MONTERAR DU DIN EMMA BOXSPRING SÄNG

1

Lägg de högra och vänstra bottenmadrasserna så att skenorna för huvudgaveln sitter på samma sida.

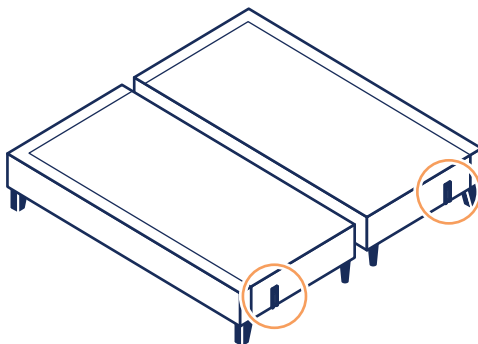

2

Fäst de 4 träbenen till de synliga hörnen på sängen.

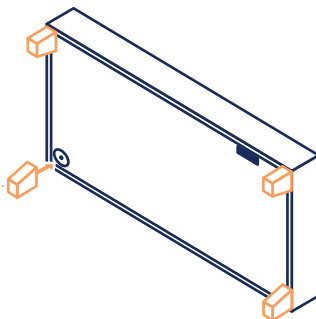

3

Placera båda kardborrebanden nära den plats där de mittersta fötterna ska skruvas fast. När fötterna har satts in kan resårerna fästas vid varandra.

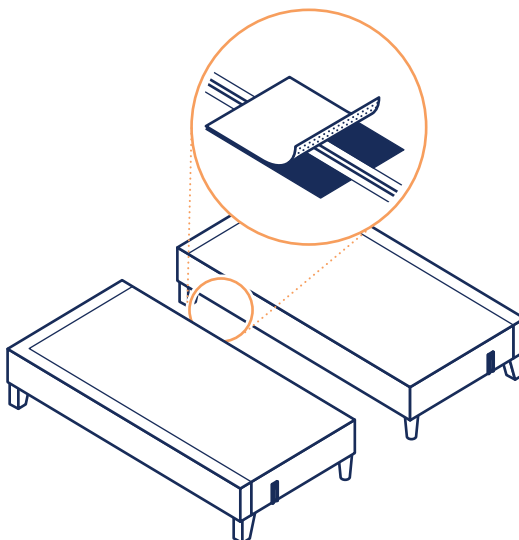

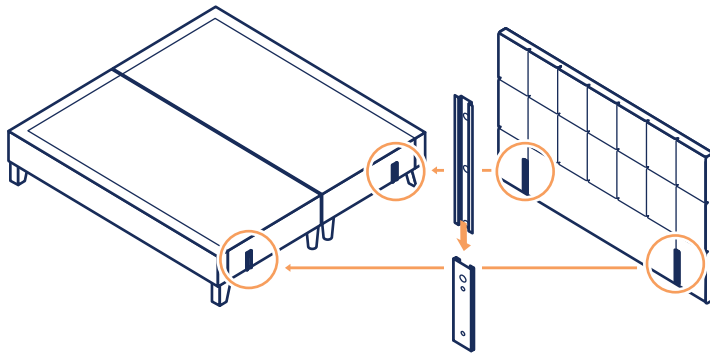

4

Fäst sedan huvudgaveln genom att dra den genom skenan tills huvudgaveln nuddar golvet.

5

Öppna upp madrassöverdraget genom att öppna dragkedjan. Läggs sedan madrassen inuti den och förslut den sedan med den vita tvättbara delen på toppen.

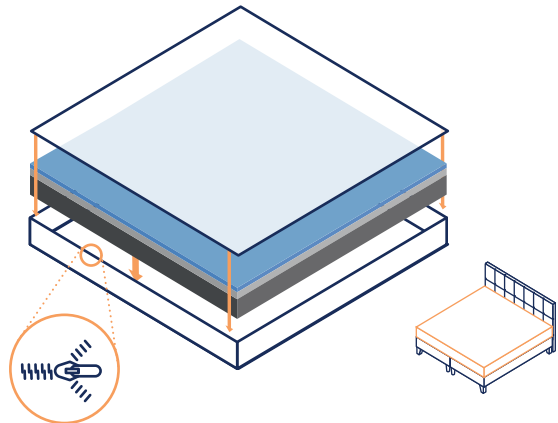

6

Slutligen är det bara att placera bäddmadrassen på toppen om du lade till den.

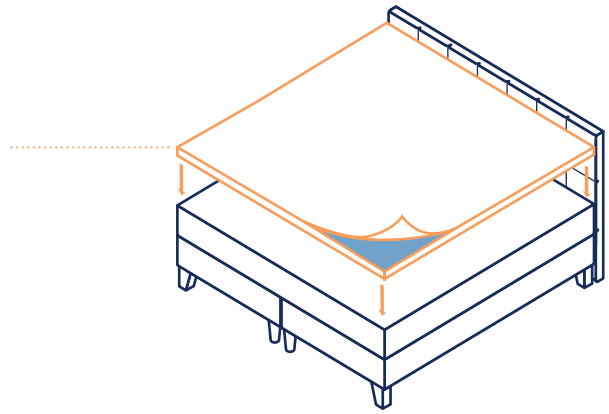

**Sov gott!**  
**Ditt Emma Team**



## VENTETIDEN ER FORBI.

Din Emma Kontinentalseng er nu virkelighed, og tiden er inde til en god nattesøvn!



## 7 GRUNDE TIL AT DU VALGTE DET RIGTIGE



1. Udvalgte materialer som kan holde længe.
2. Ekstra højde for mere komfort: så du nemmere kan komme i seng og op om morgen.
3. Træben for at give din seng god stabilitet.
4. Springbasen fra Bonell for forbedret ergonomi.
5. Vores ekstra bløde hovedgærde, så du kan læne dig tilbage og slappe af.
6. 7 zoners pocket springmadras for at give dig en bedste støtte hele natten.
7. Topmadrassen giver ekstra komfort.



## VORES ANBEFALING TIL DEN PERFEKTE SØVN:



Rengør betrækket hver 6 måned.  
Det er let at fjerne og kan maskinvaskes (40 °C).



Tag dig tid til dig selv  
og nyd en god bog inden søvn.



Vend din topmadras  
hver 3 måned.



## SÅDAN SAMLER DU DIN EMMA KONTINENTALSENG

1

Placer venstre og højre sengebund ved siden af hinanden, så skinnerne til at fastgøre hovedgærdet er på samme side.

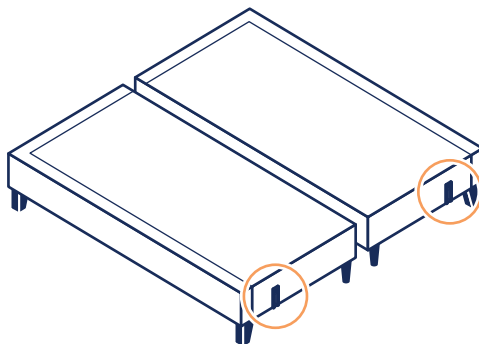

2

Fastgør de fire træben til sengens hjørner.

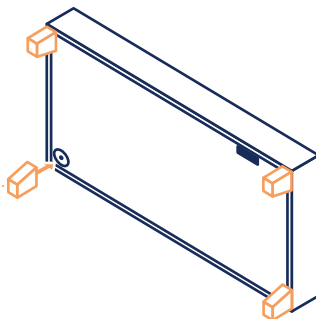

3

Placér begge velcrolukninger tæt på, hvor de midterste fødder skal skrues i. Når fødderne er sat på, kan delene fastgøres til hinanden.

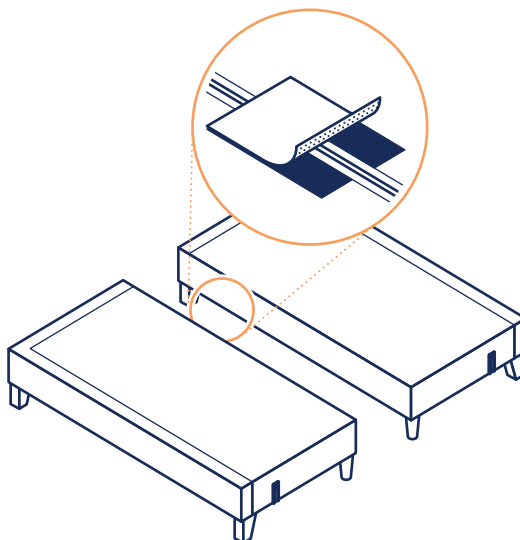

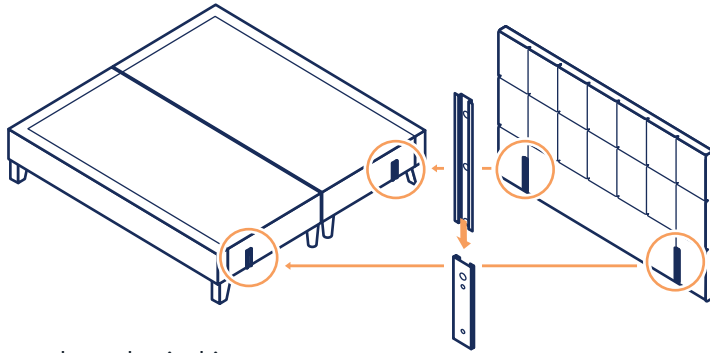

4

Skub hovedgærdet ind i skinnerne på forsiden af sengen indtil sengegavlen rører ved gulvet.

5

Åben lynlåsen på betrækket og placer madrassen indeni. Luk lynlås med den hvide side på toppen.

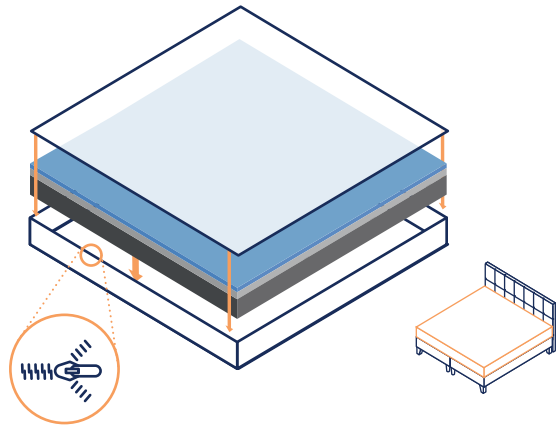

6

Til slut skal du placere din topmadræs ovenpå madrassen.

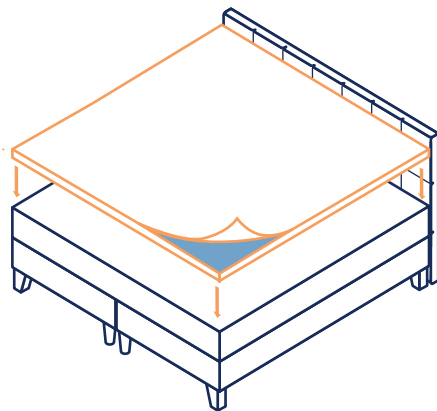

**Sov godt!**  
**Dit Emma Team**

Emma®