

Emma®

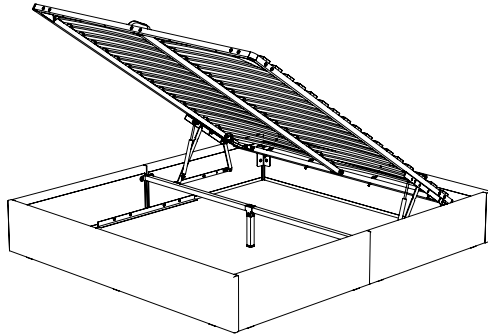

140×190 → pages 3 - 15

140×200 → pages 18 - 30

160×200, 180×200 → pages 33 - 45

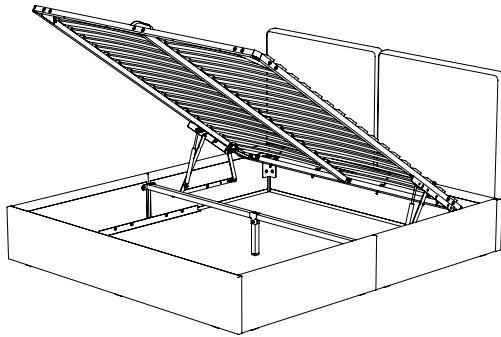

140×190 → pages 3 - 17

140×200 → pages 18 - 32

160×200, 180×200 → pages 33 - 47



EN

WARNING! (RETAIN FOR FUTURE REFERENCE):

Slatted frame must NOT be closed without the mattress. The mattress should be put on top of the open frame, then the bed can be closed by applying pressure on top of the mattress foot-end.

Do not pull the handle to close the slatted frame. Keep hands away from the mechanism when opening or closing. Never reach through mechanism to access storage area.

Always ensure that the ottoman is FULLY opened before accessing the storage area.

Do not sit on the opened bed frame. Do not place hands on the edges of the frame when closing.

DE

WARNUNG! (FÜR DIE ZUKUNFT GUT AUFBEWAHREN)

Der Lattenrost darf ohne Matratze NICHT gewaltsam geschlossen werden.

Die Matratze sollte auf den offenen Rahmen platziert werden, dann kann das Bett geschlossen werden, indem Druck auf das Fußende der Matratze ausgeübt wird.

Ziehen Sie nicht am Griff, um den Lattenrost zu schließen.

Halten Sie beim Öffnen und Schließen die Hände vom Schließmechanismus fern.

Nie durch den Schließmechanismus greifen, um an den Stauraum zu gelangen.

Vergewissern Sie sich immer, dass der Bettkasten VOLLSTÄNDIG geöffnet ist, bevor Sie auf den Stauraum zugreifen. Setzen Sie sich nicht auf den geöffneten Bettrahmen.

Legen Sie Ihre Hände beim Schließen nicht auf die Kanten des Bettrahmens.

FR

AVERTISSEMENT! (A CONSERVER POUR RÉFÉRENCE FUTURE) :

Le sommier ne doit PAS être refermé de force sans le matelas.

Le matelas doit être placé sur le dessus du sommier ouvert, puis le lit peut être fermé en appliquant une pression le dessus du matelas (au niveau des pieds).

Ne tirez pas sur la poignée pour fermer le sommier.

Ne pas approcher les mains du mécanisme lors de l'ouverture ou de la fermeture.

Ne passez jamais la main à travers le mécanisme pour accéder à l'espace de rangement.

Assurez vous toujours que le mécanisme est entièrement ouvert avant d'accéder à la zone de stockage. Ne vous asseyez pas sur le sommier ouvert.

Ne pas placer les mains sur les bords du cadre lors de la fermeture.

PT

AVISO! (GUARDAR PARA REFERÊNCIA FUTURA)

NÃO forçar o fecho do estrado quando este não tiver colchão em cima.

O colchão deve ser colocado com o estrado aberto para que depois a cama possa ser fechada através da aplicação de pressão na extremidade do colchão.

Não utilizar a pega para fechar o estrado.

Manter as mãos afastadas do mecanismo de abertura aquando da abertura ou fecho da cama.

Nunca utilizar a zona do mecanismo de abertura para aceder à zona de arrumação.

Ter sempre a certeza de que o estrado está COMPLETAMENTE ABERTO aquando do acesso à zona de arrumação.

Não sentar na cama enquanto esta tem o estrado aberto.

Não colocar as mãos na estrutura da cama aquando do fecho da mesma.



140×190

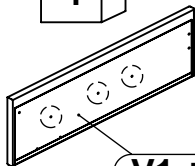

V1 + V2

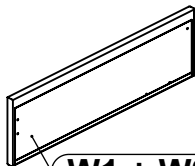

W1 + W2

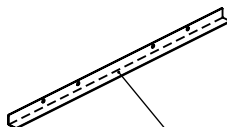

3x

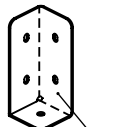

4x Y



2x E

a



28×M6
20mm

b



5×M6
40mm



1×M6
Inbus



1×M6
Wrench



1×M6
Washer



1×M6
Nut



10×Felt
Sticker

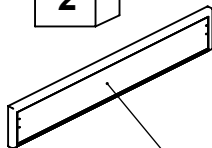

F

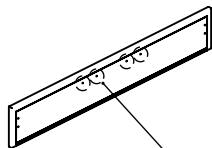

G

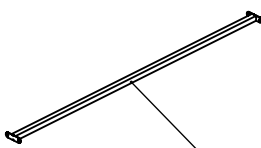

H

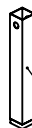

I

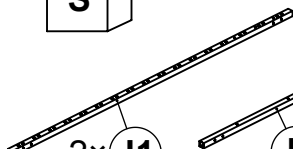

2x J1

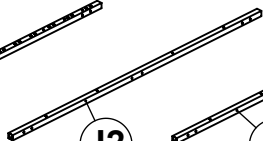

J2

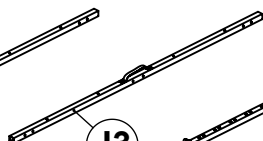

J3

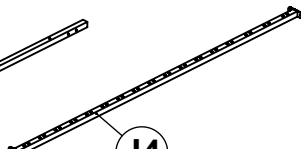

J4

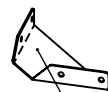

4x K

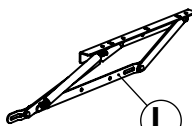

L

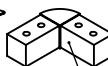

4x M



32×N1



16×N2



O



6×M6
20mm



26×M6
50mm



16×P

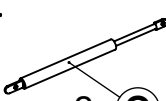

2×Q

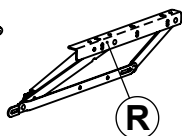

R



S



32×M6
Washer



32×M6
Nut

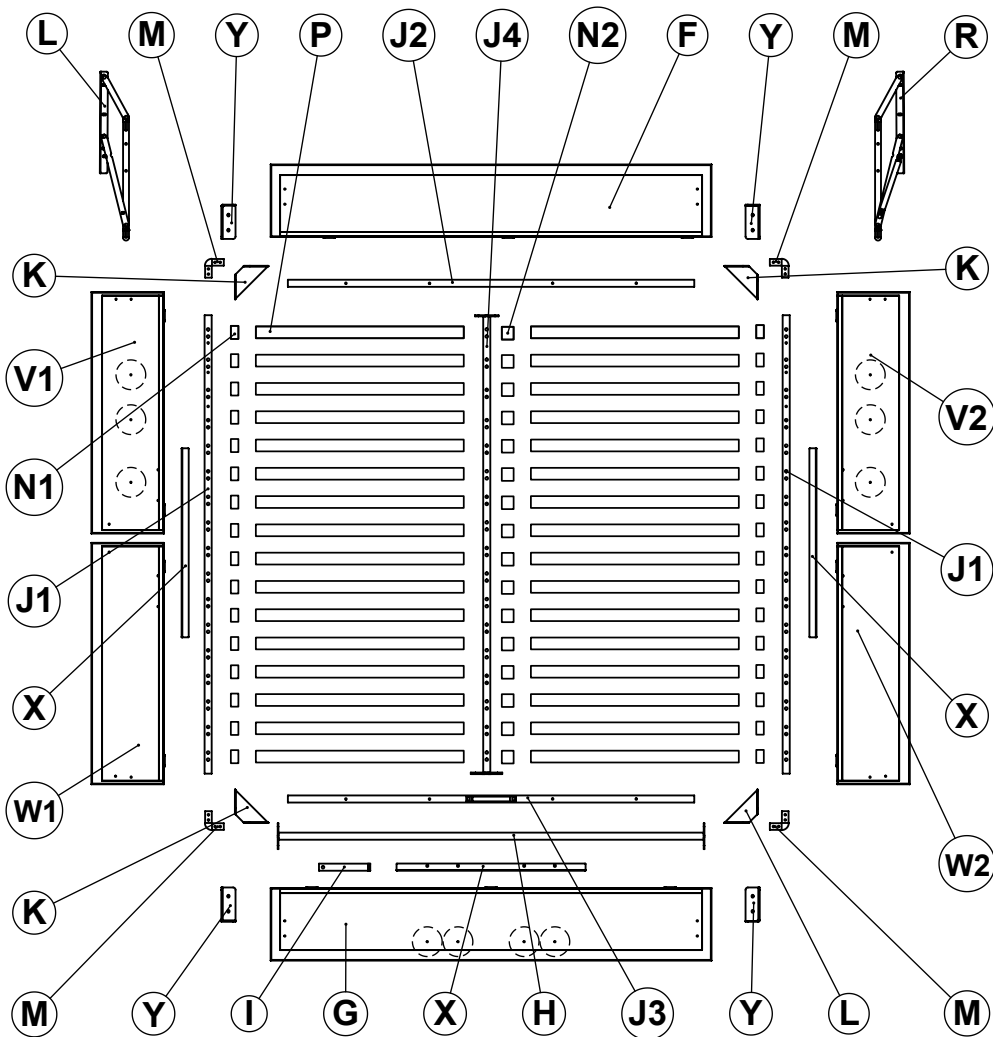
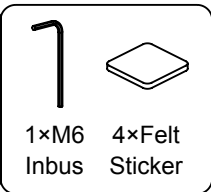
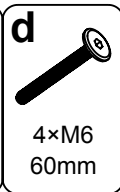
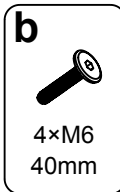
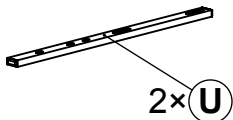
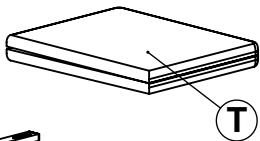

2x

1

4xM6
20mm

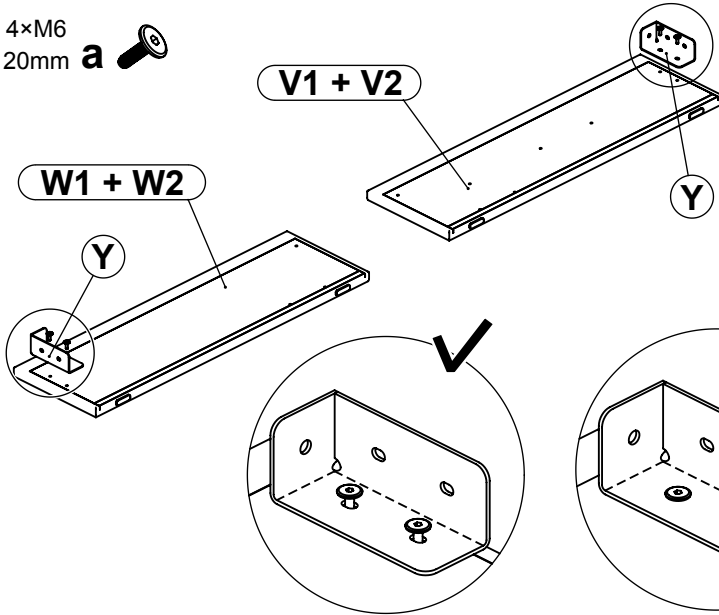

2

4xM6
20mm



4xM6
40mm

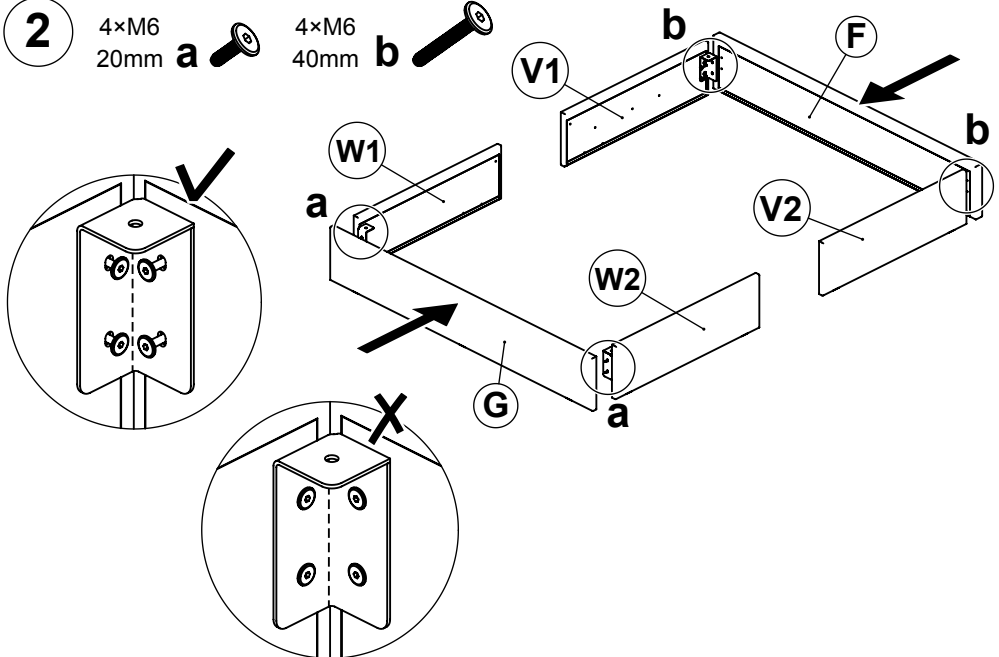

3

M6
Inbus

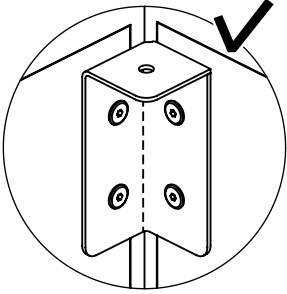
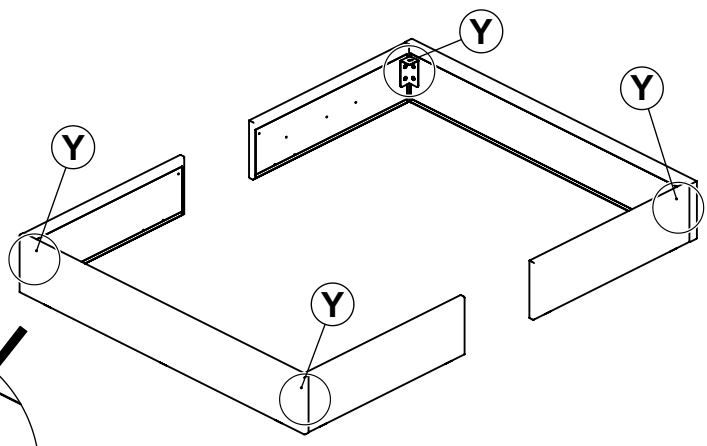
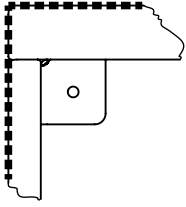

4

4×M6
20mm

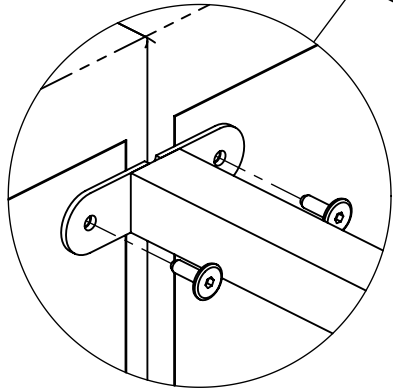
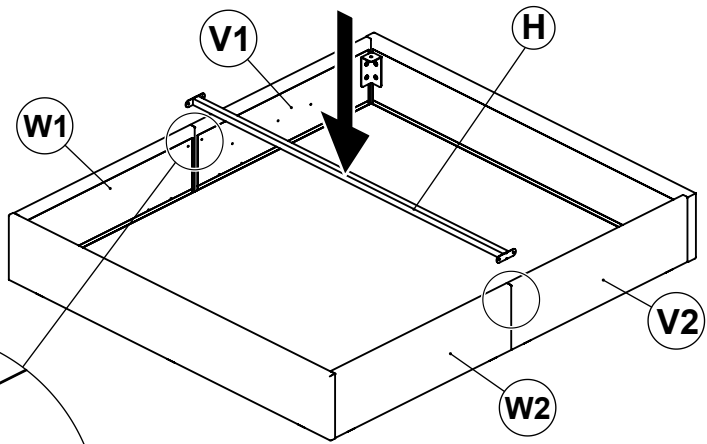

5

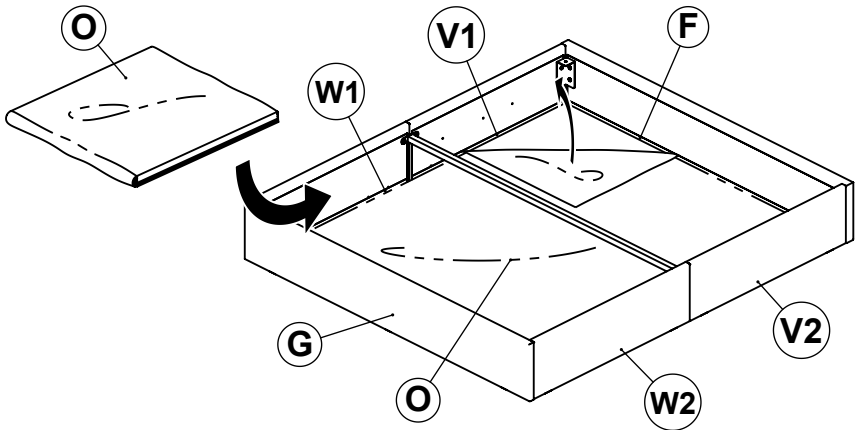

6

8×M6
20mm a 

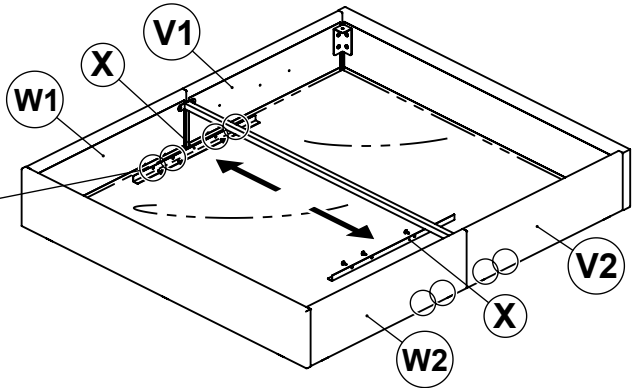
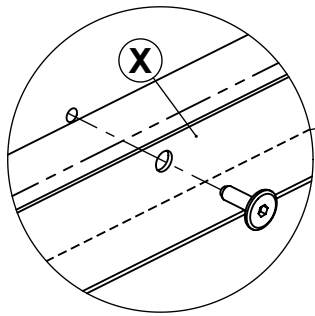

7

4×M6
20mm a 

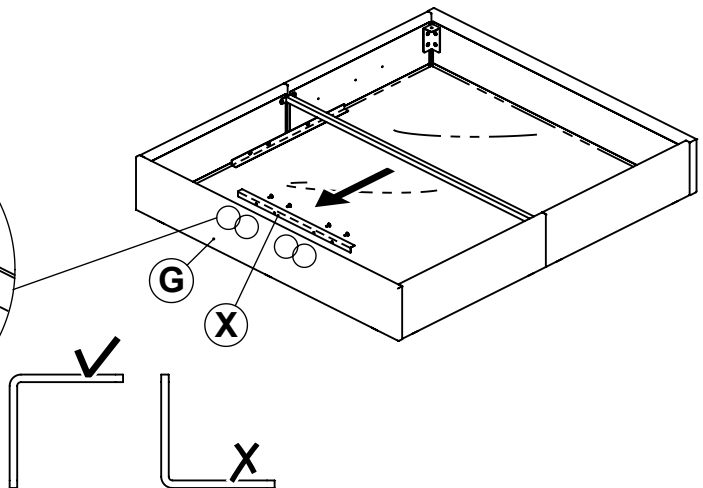
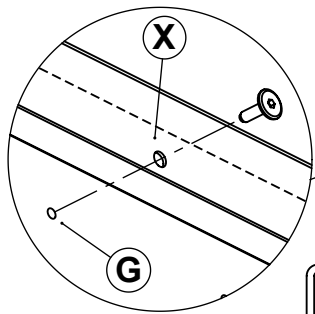

8

1×M6
40mm



1×M6
Washer



1×M6
Nut



M6
Wrench



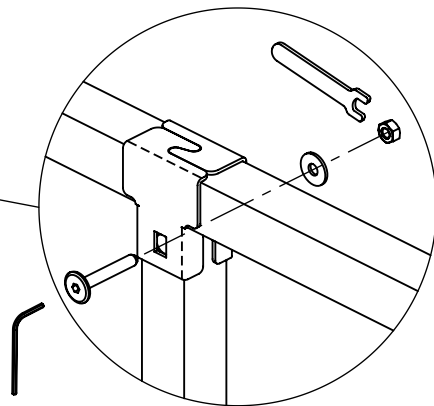
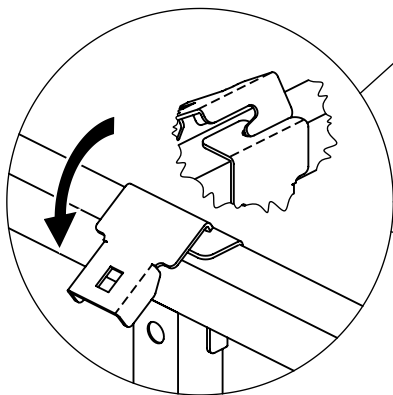
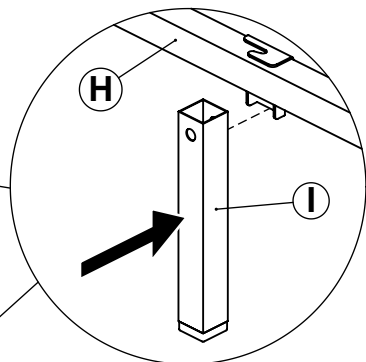
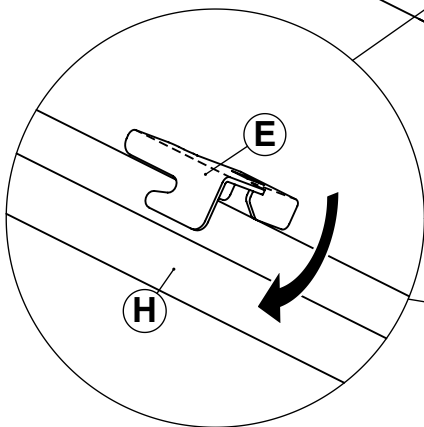
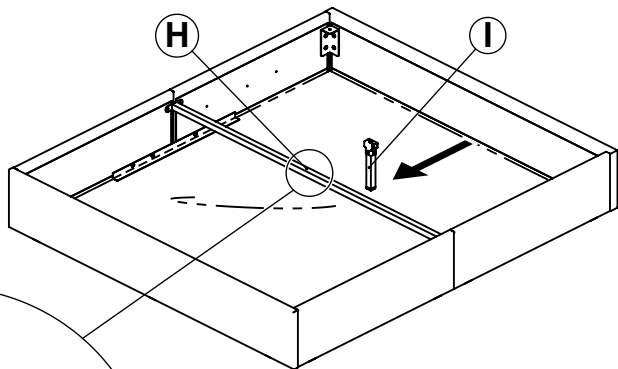

M6
Inbus

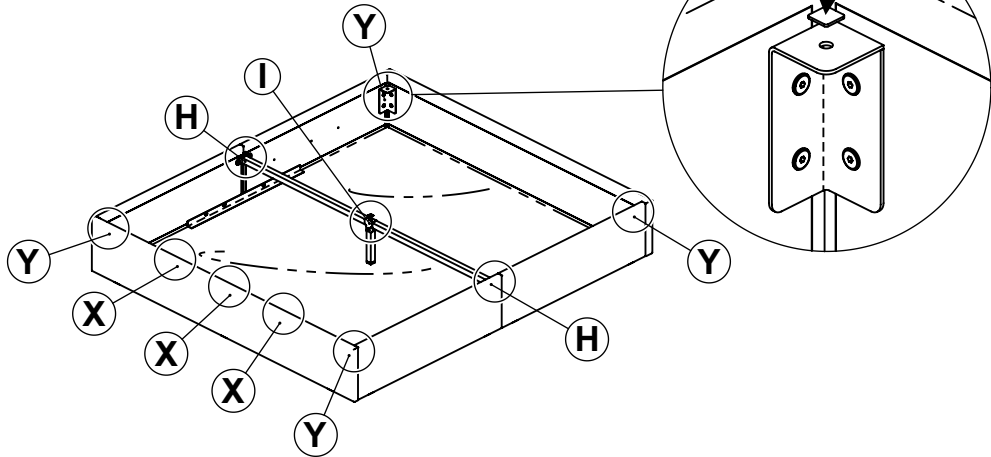

9 10×Felt
Sticker

10 16×M6
50mm  16×M6
Washer  16×M6
Nut 

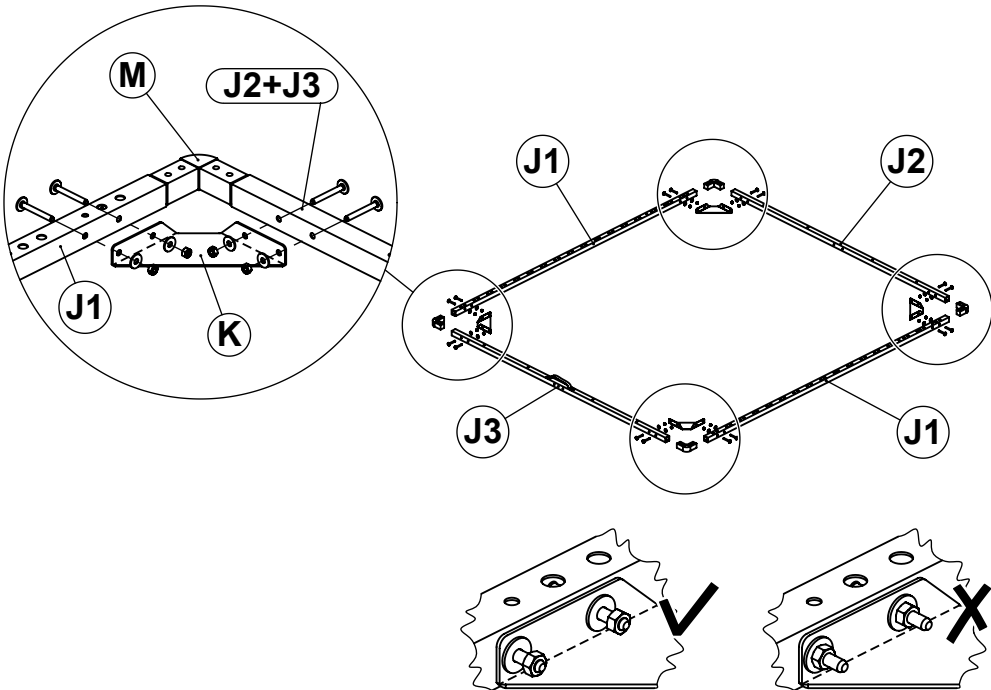

11

4×M6
50mm



4×M6
Washer



4×M6
Nut

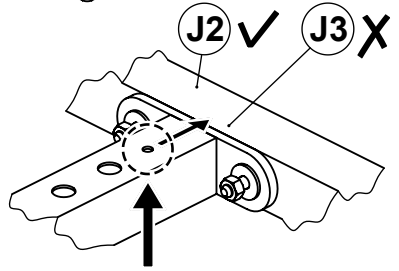
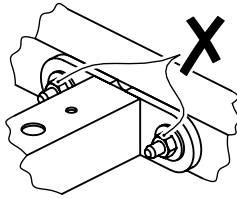
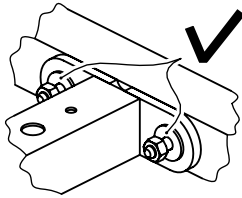
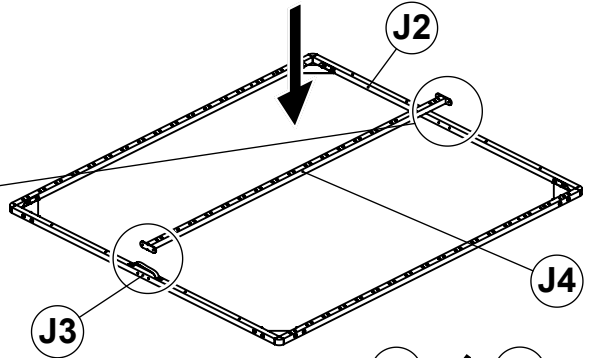
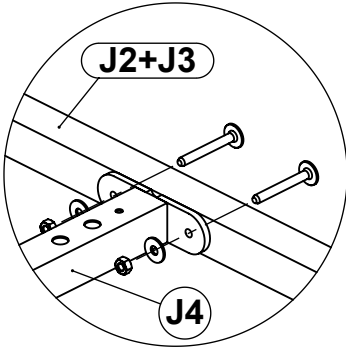

12

M6
Wrench



M6
Inbus

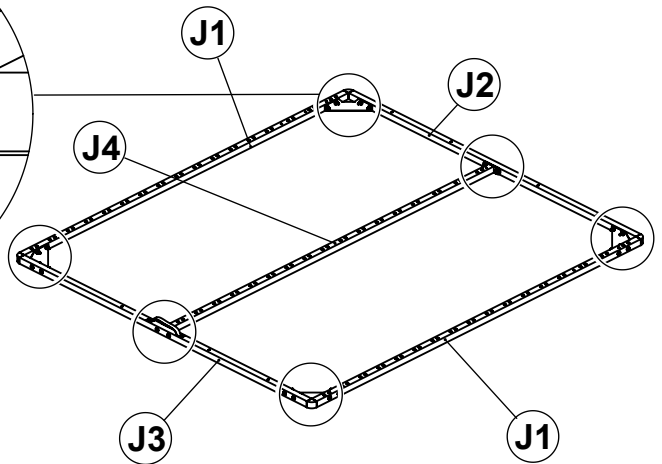
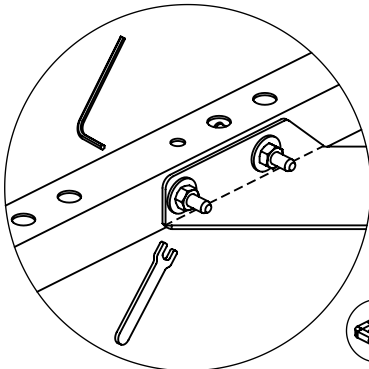

16x

13

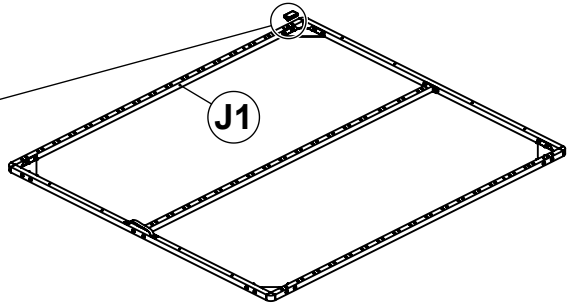
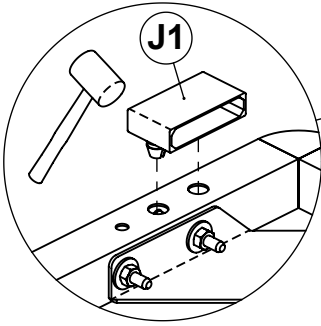

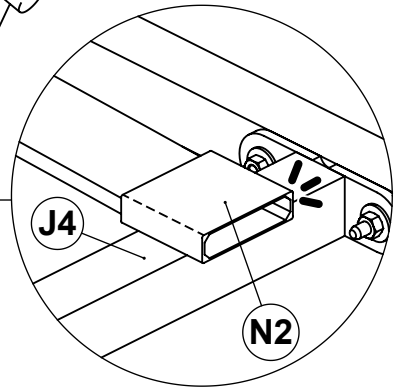
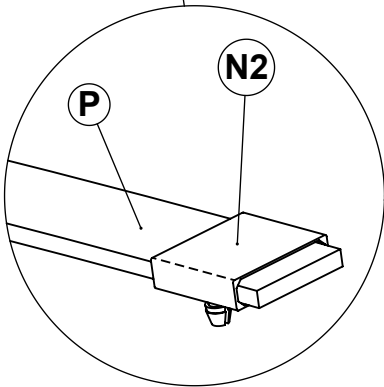
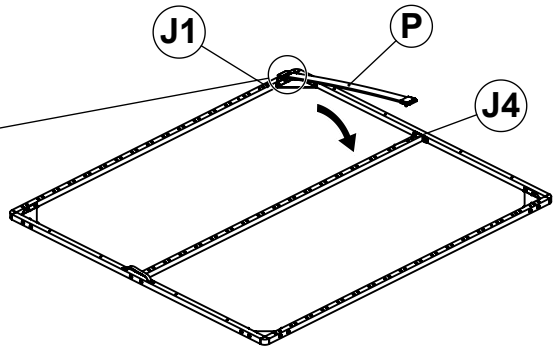
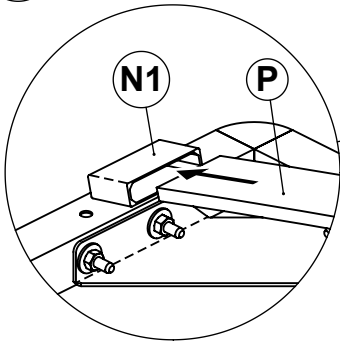

14

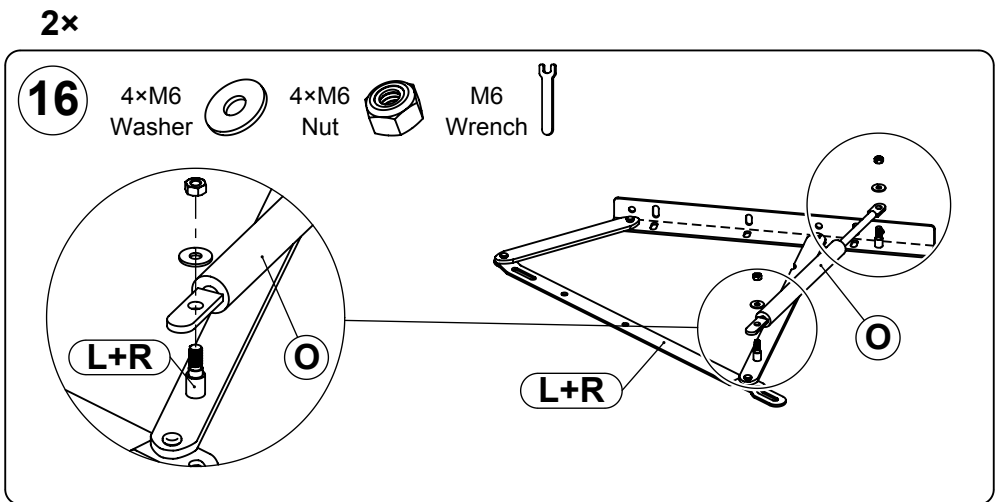
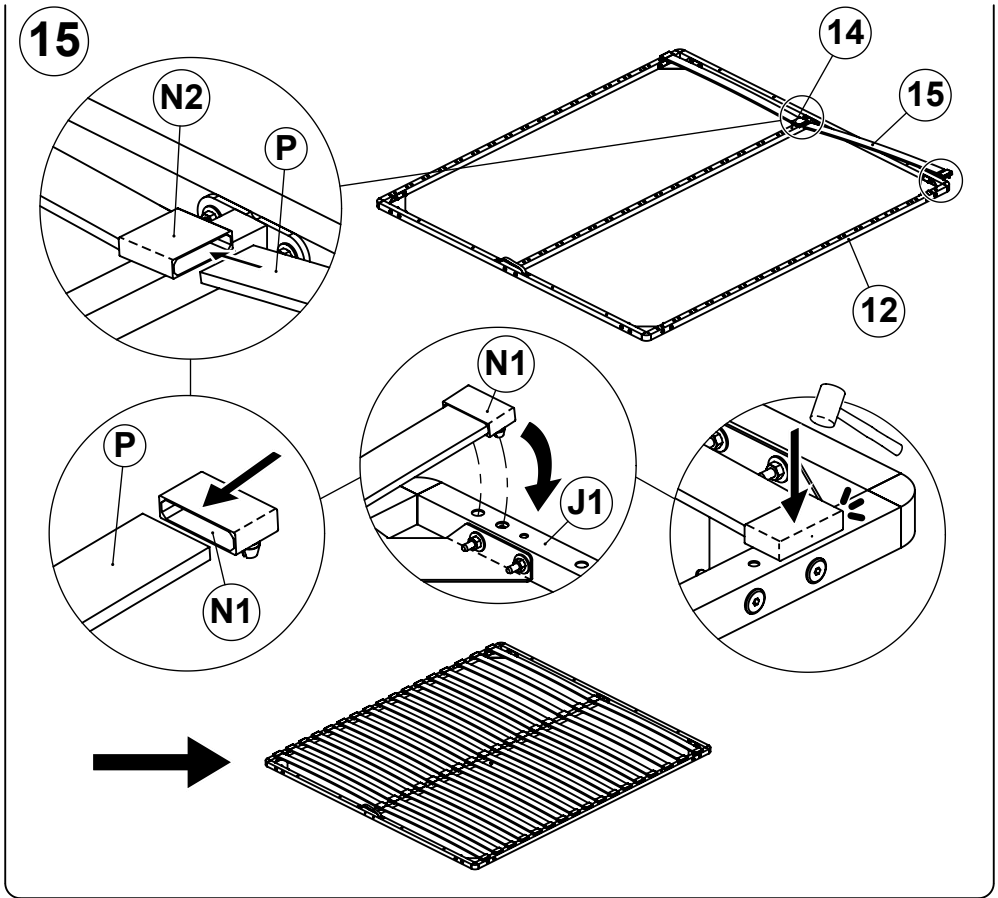

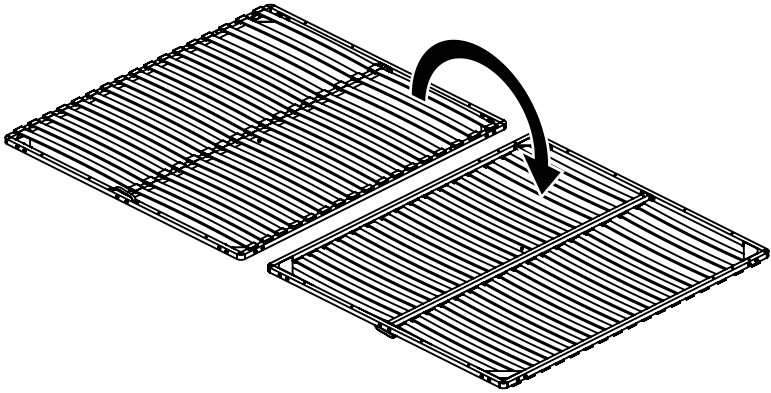

17



18 6×M6
50mm C 

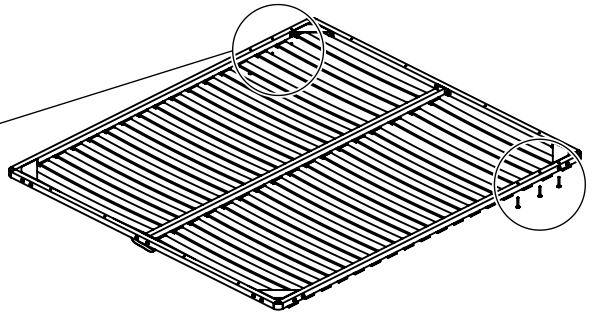
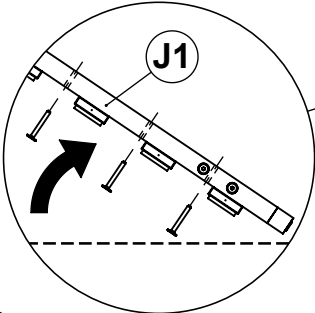

19 6×M6 Washer  6×M6 Nut 

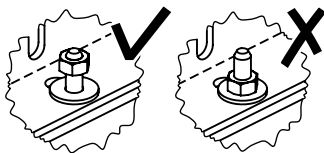
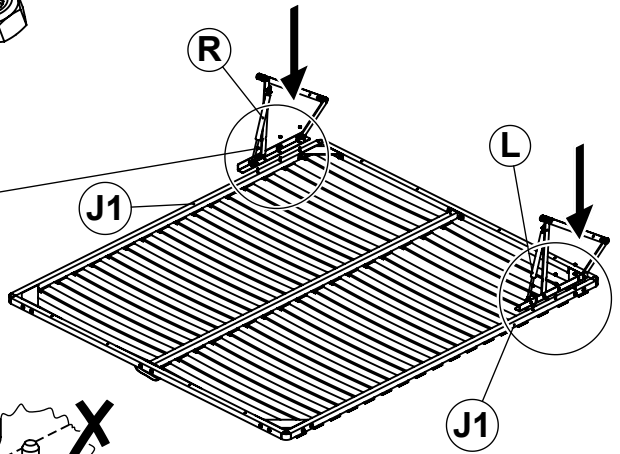
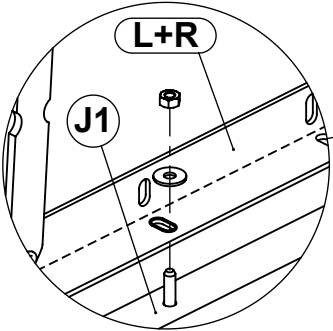

20

M6
Wrench



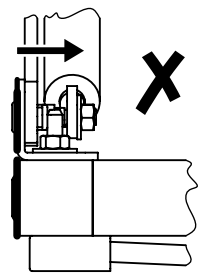
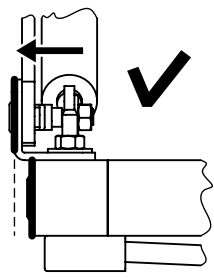
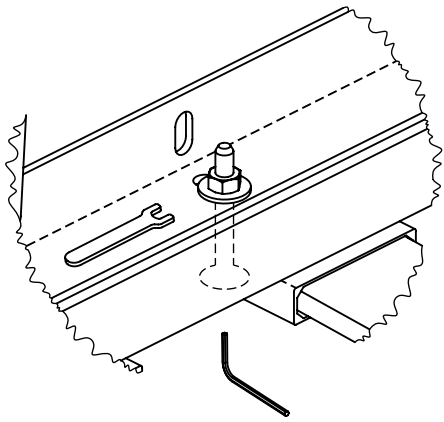

M6
Inbus

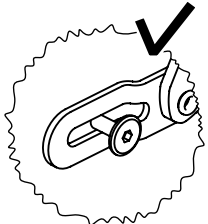
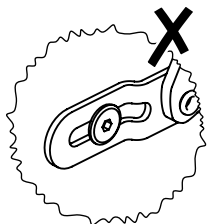
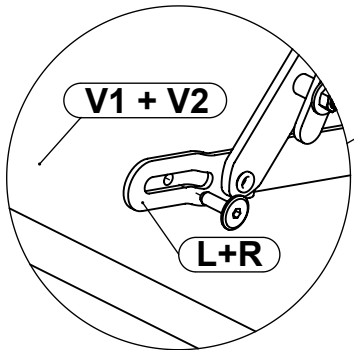
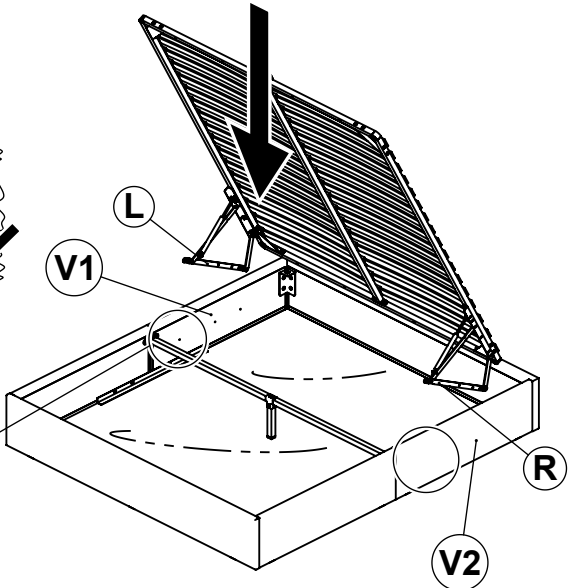
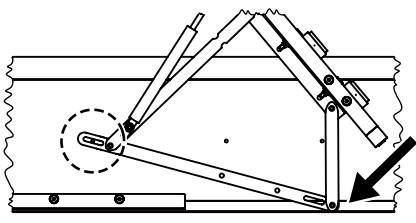

21

2×M6
20mm



22 4×M6
20mm **a** 

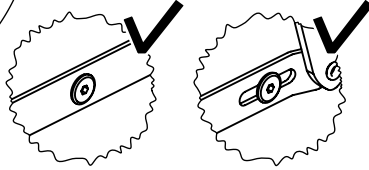
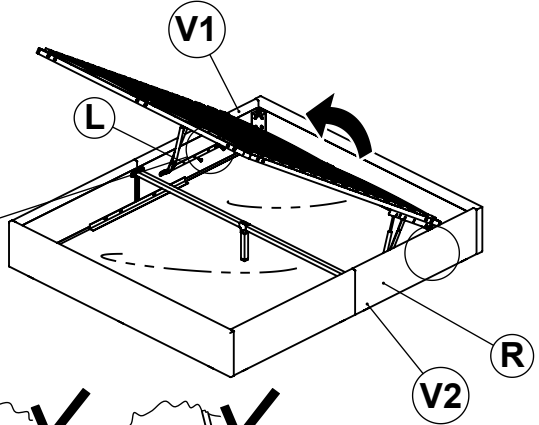
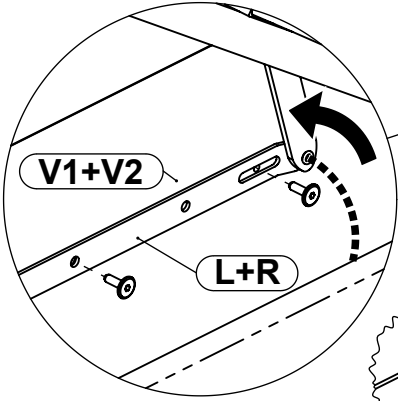

23 2×M6 Washer  2×M6 Nut 

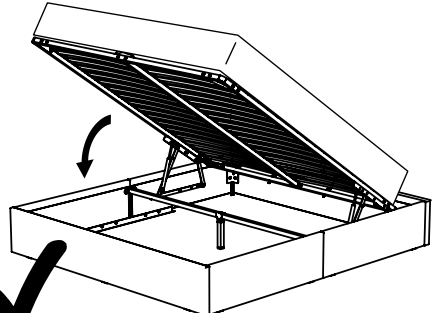
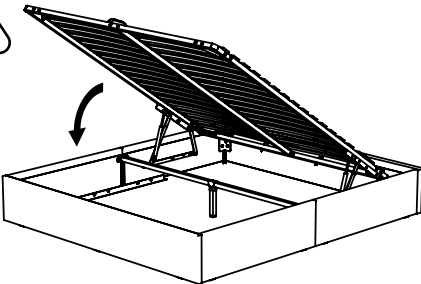
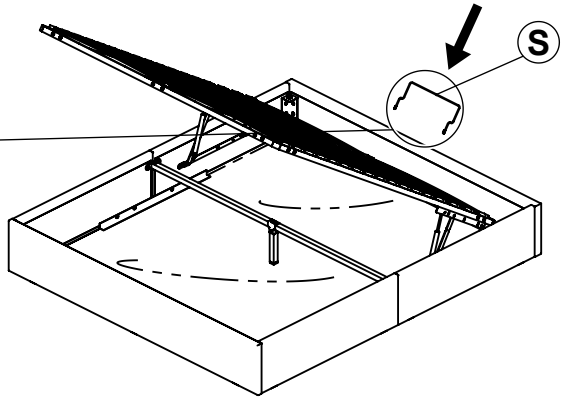
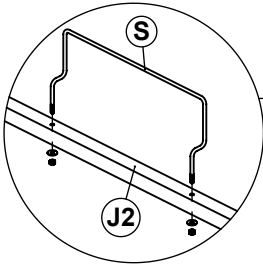

24

4×M6
60mm

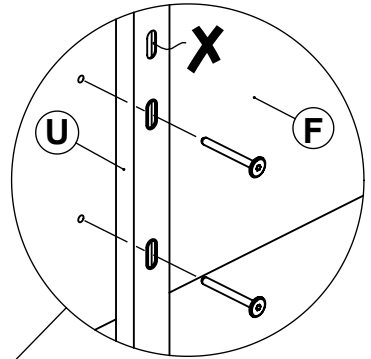
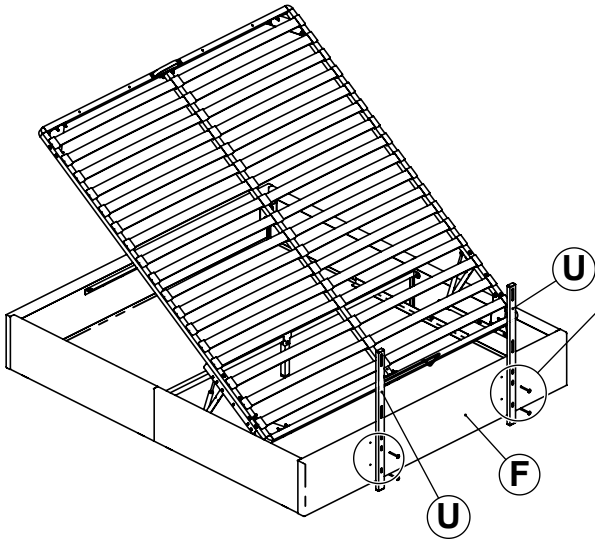

V1 + V2

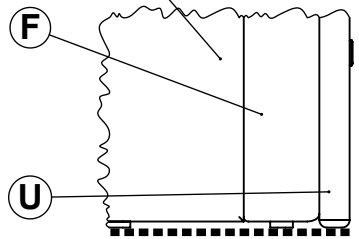

25

4×M6
40mm

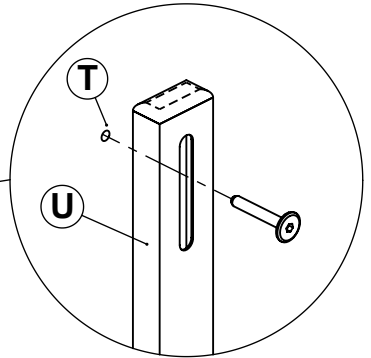
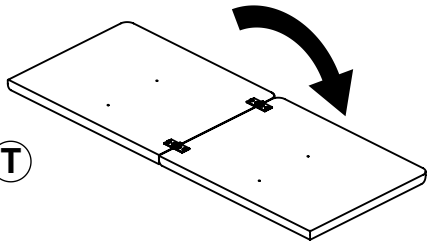
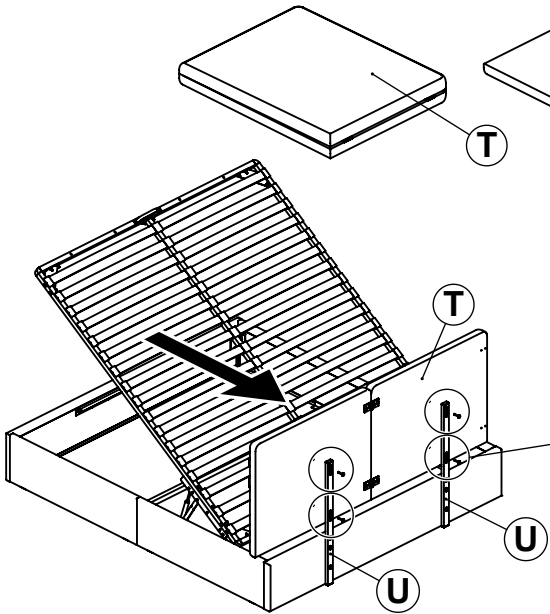

26

4×Felt
Sticker

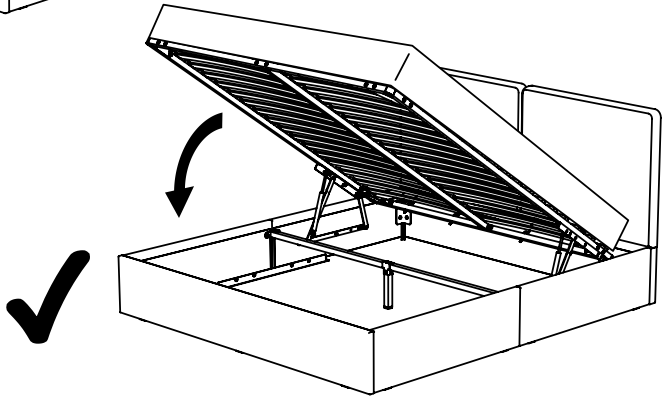
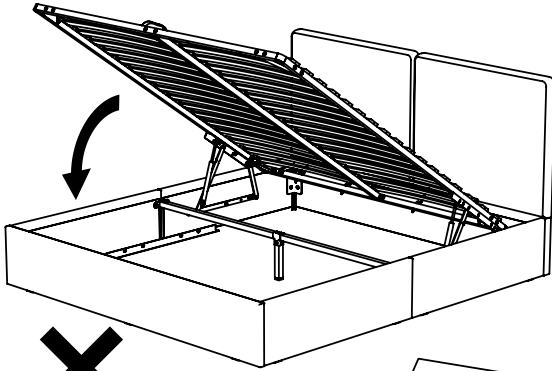
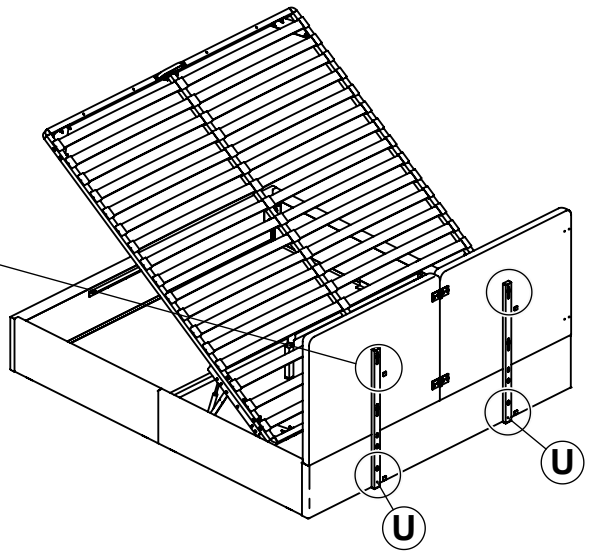
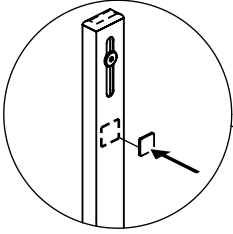



140x200

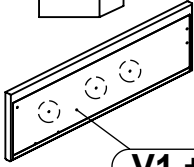

V1 + V2

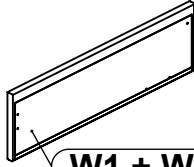

W1 + W2

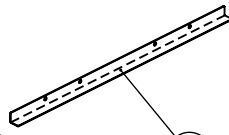

3x

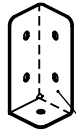

4x Y



2x E



28xM6
20mm



5xM6
40mm



1xM6
Inbus



1xM6
Wrench



1xM6
Washer



1xM6
Nut



10x Felt
Sticker

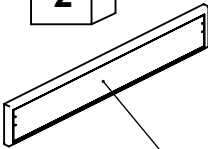

F

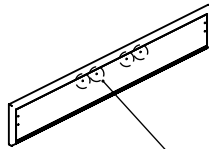

G

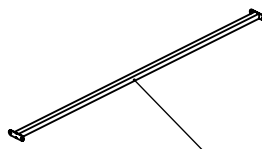

H

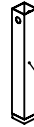

I

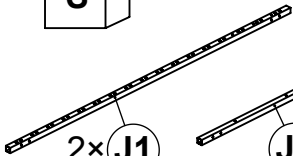
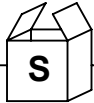

2x J1

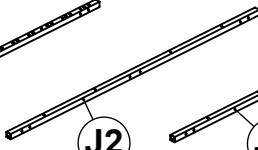

J2

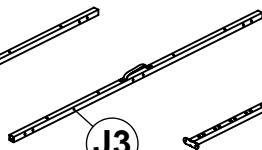

J3

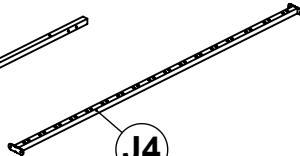

J4

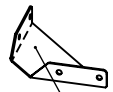

4x K

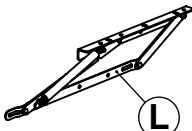

L



4x M



34x N1



17x N2



O

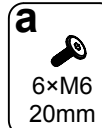

6xM6
20mm

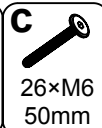

26xM6
50mm

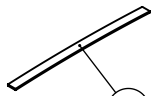

17x P

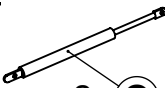

2x Q

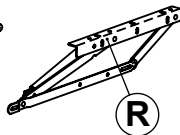

R

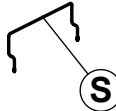

S

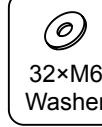

32xM6
Washer

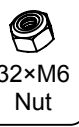

32xM6
Nut

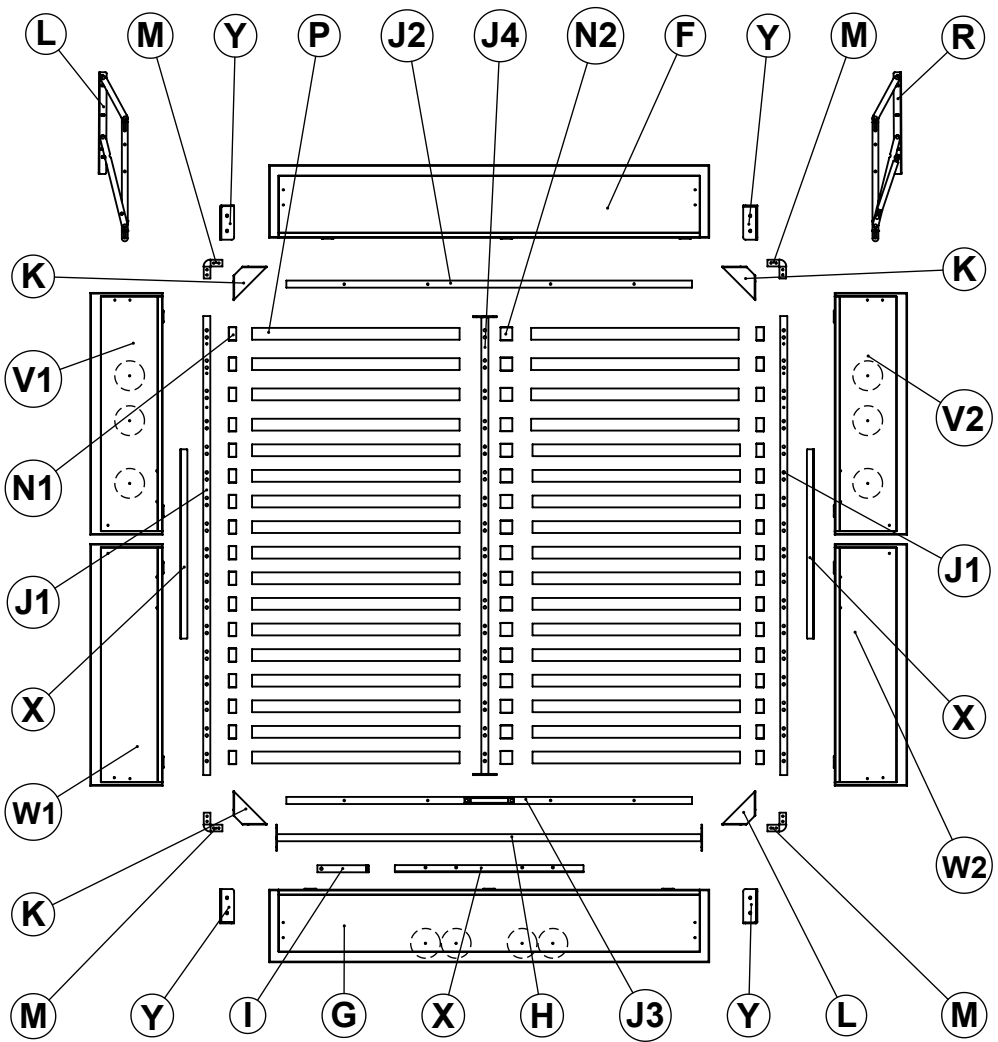
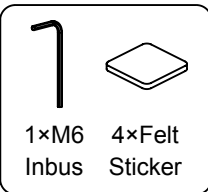
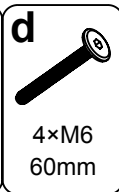
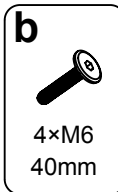
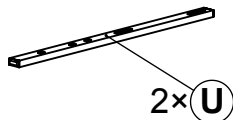
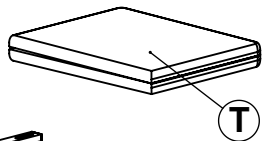
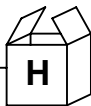

2x

1

4xM6
20mm

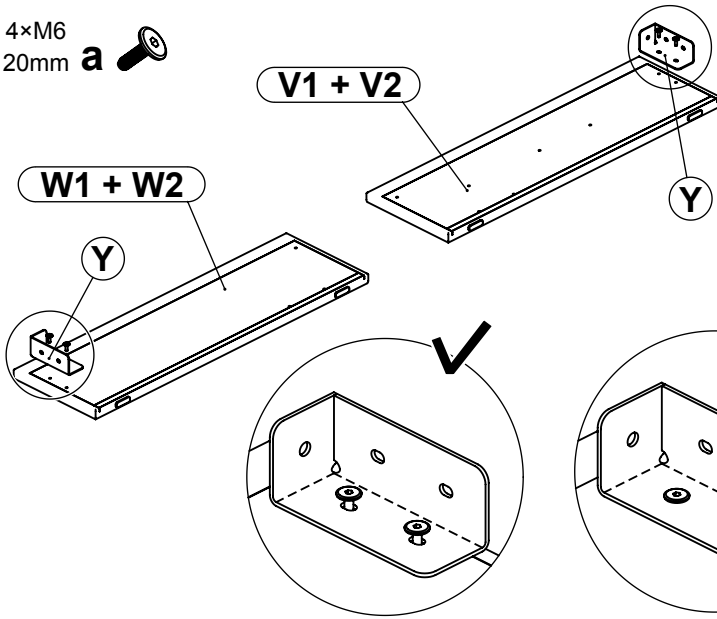

2

4xM6
20mm



4xM6
40mm

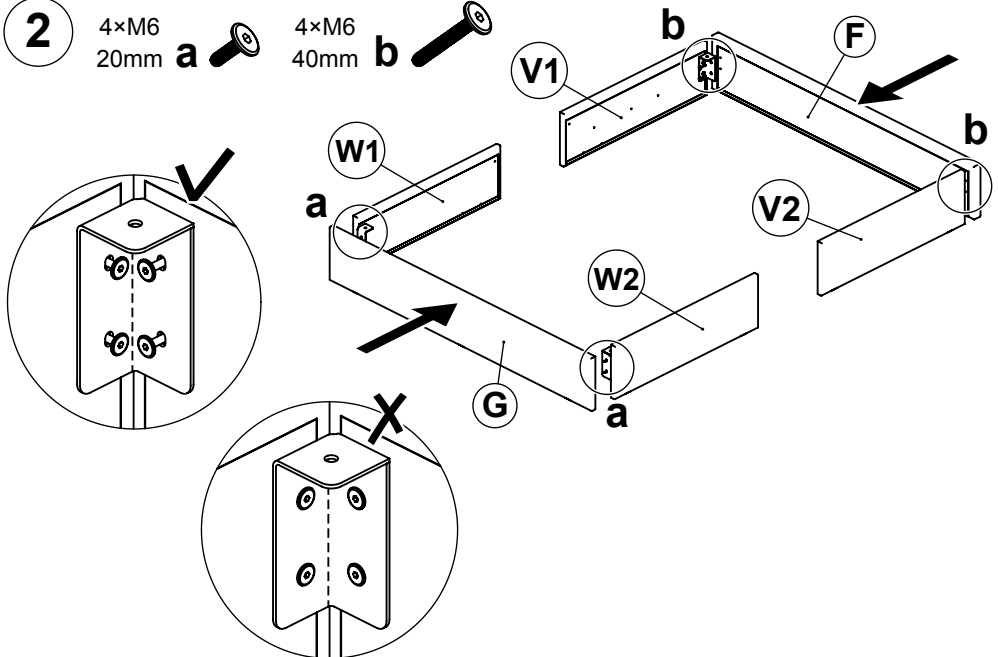

3

M6
Inbus

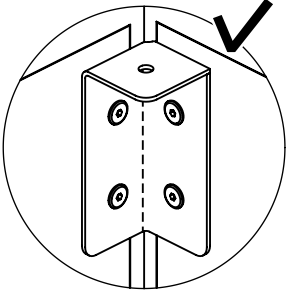
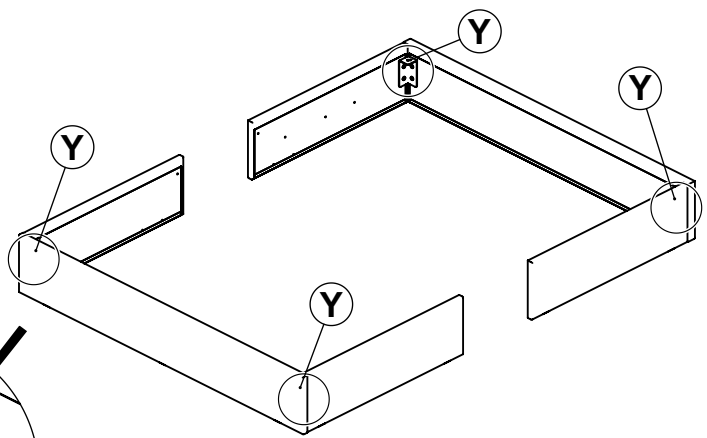
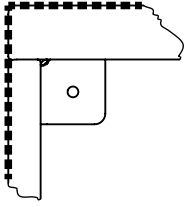

4

4×M6
20mm

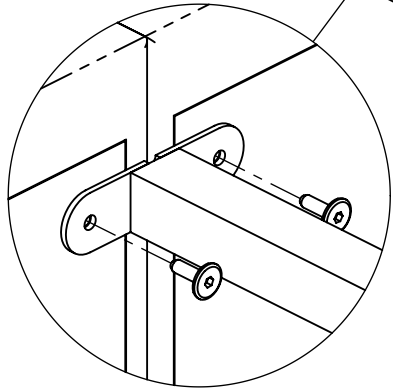
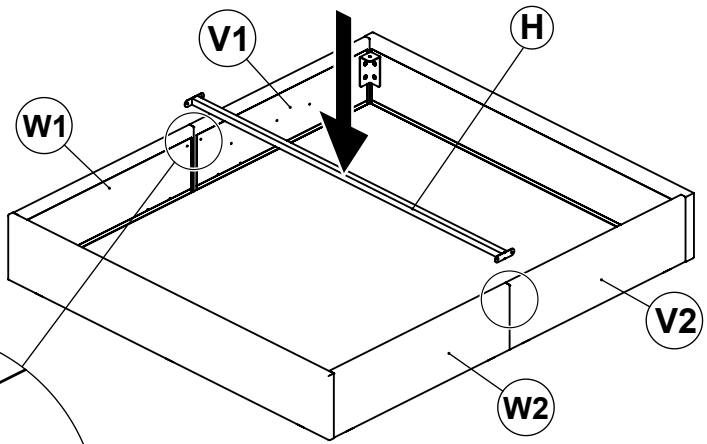

5

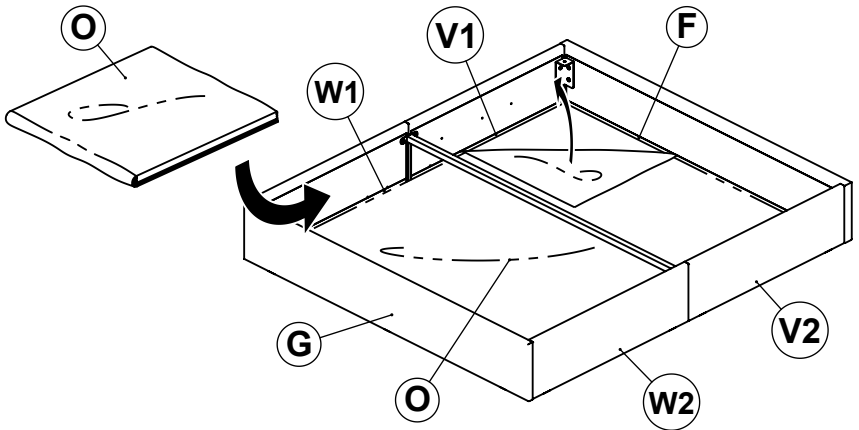

6

8×M6
20mm a

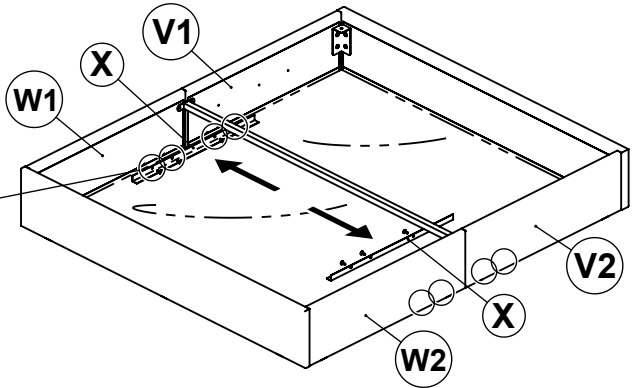
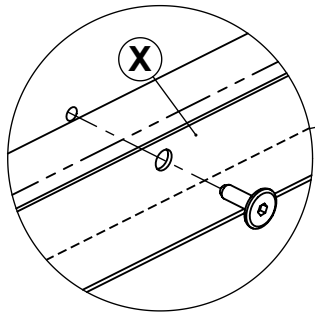

7

4×M6
20mm a

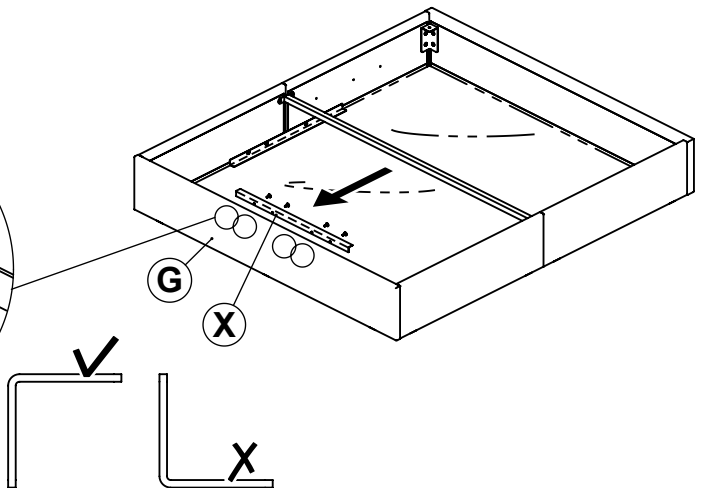
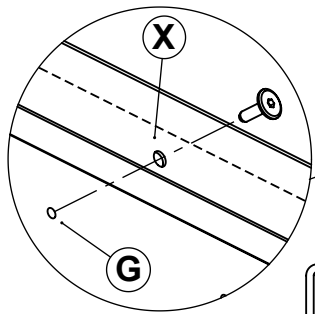

8

1×M6
40mm



1×M6
Washer



1×M6
Nut



M6
Wrench



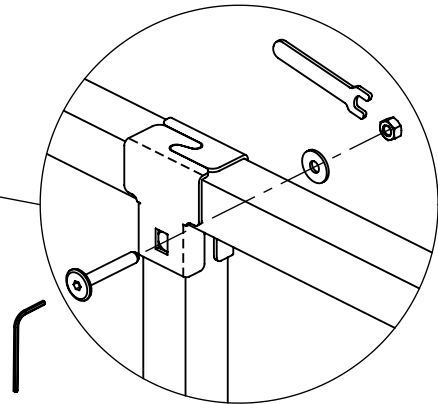
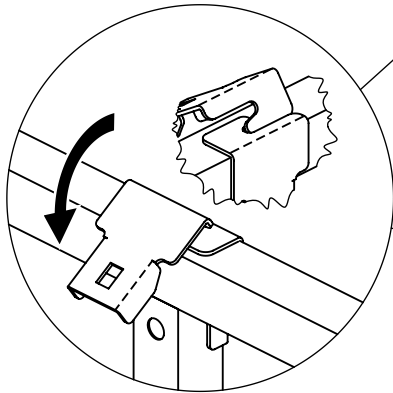
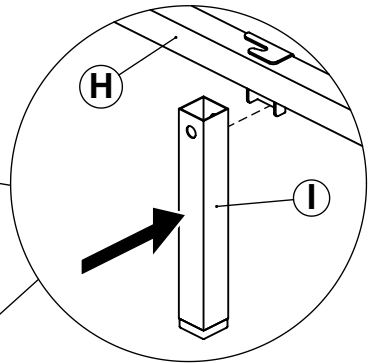
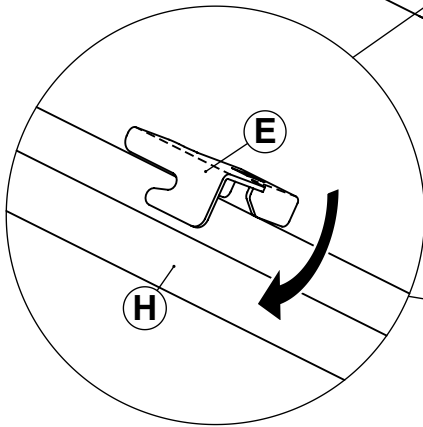
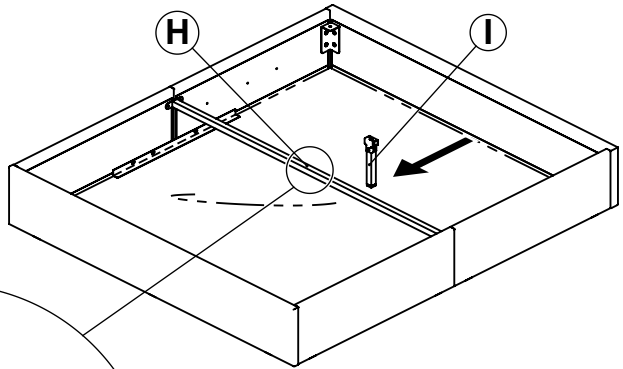

M6
Inbus

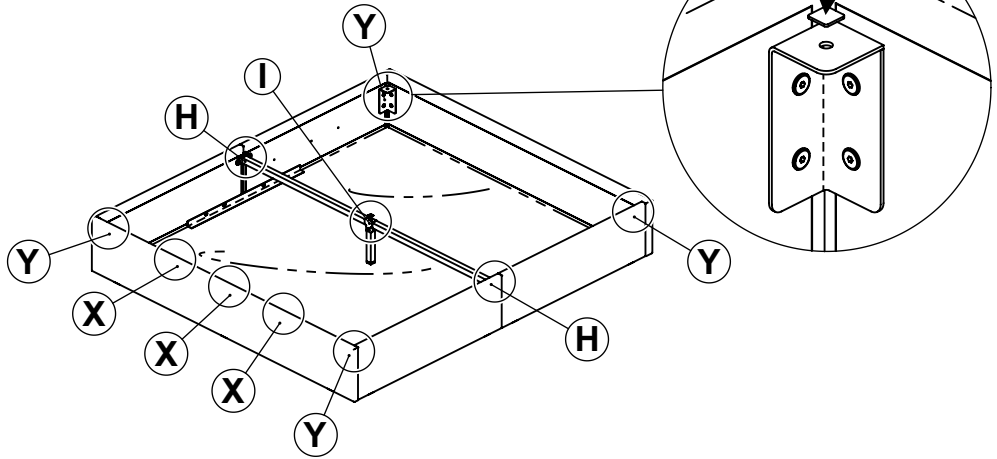

9 10×Felt
Sticker

10 16×M6
50mm  16×M6
Washer  16×M6
Nut 

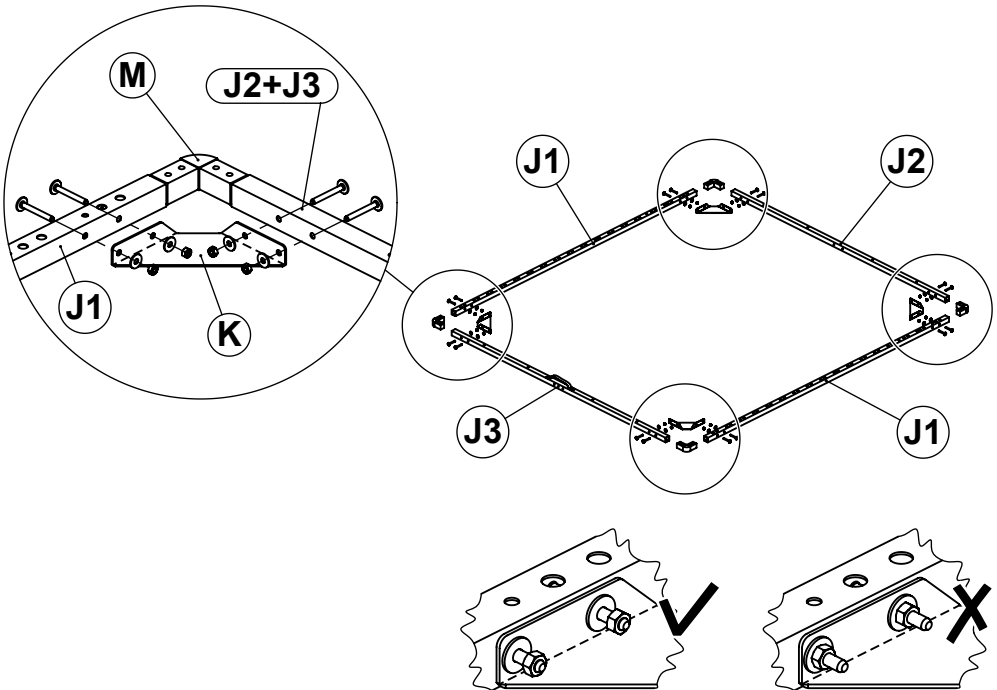

11

4×M6
50mm



4×M6
Washer



4×M6
Nut

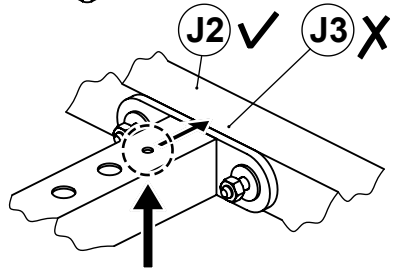
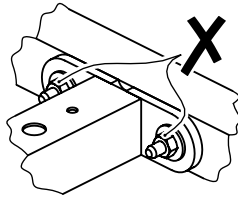
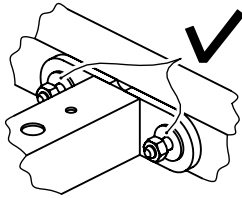
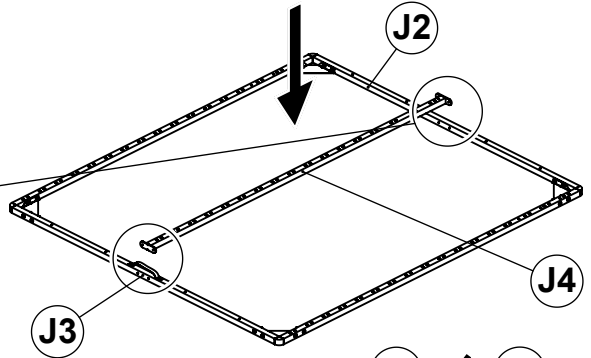
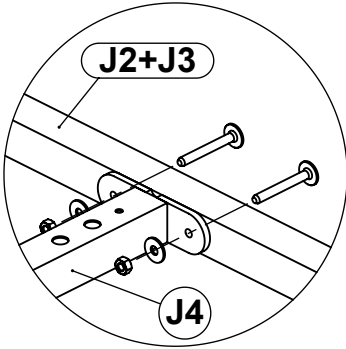

12

M6
Wrench



M6
Inbus

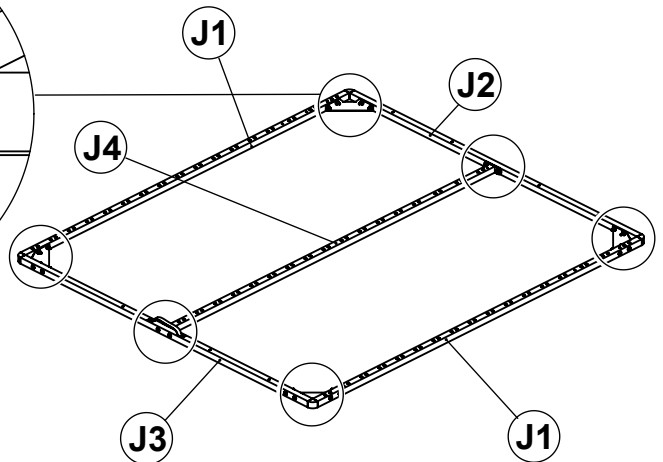
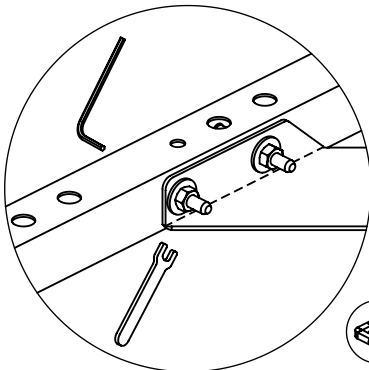

13

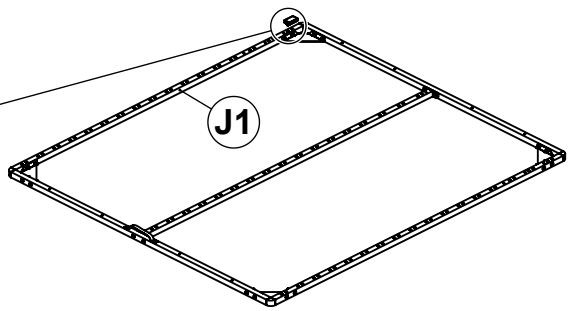
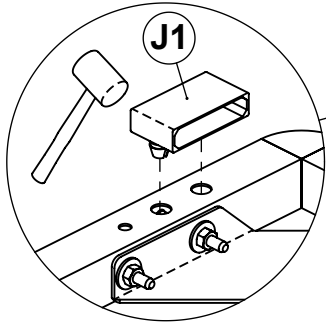

14

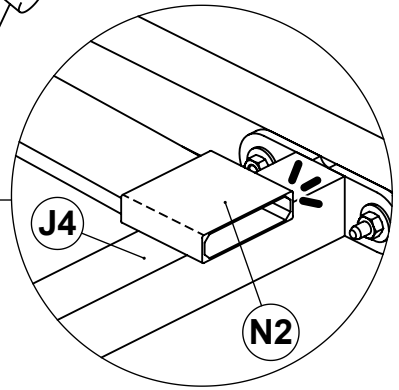
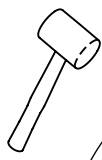
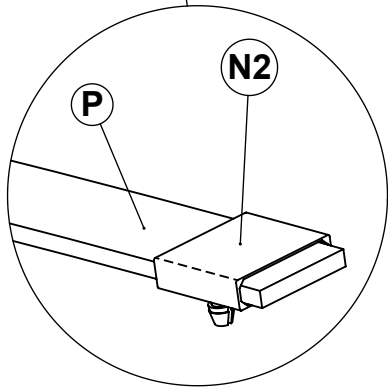
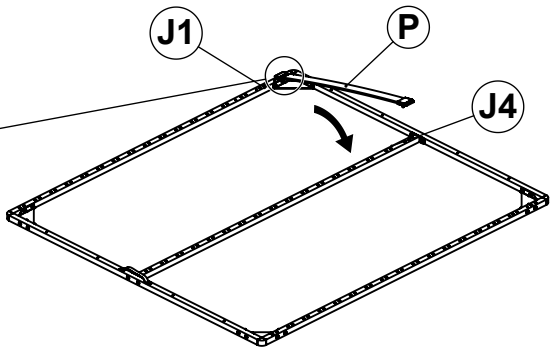
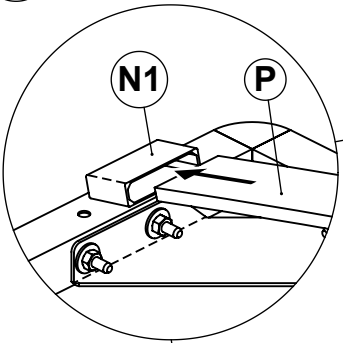

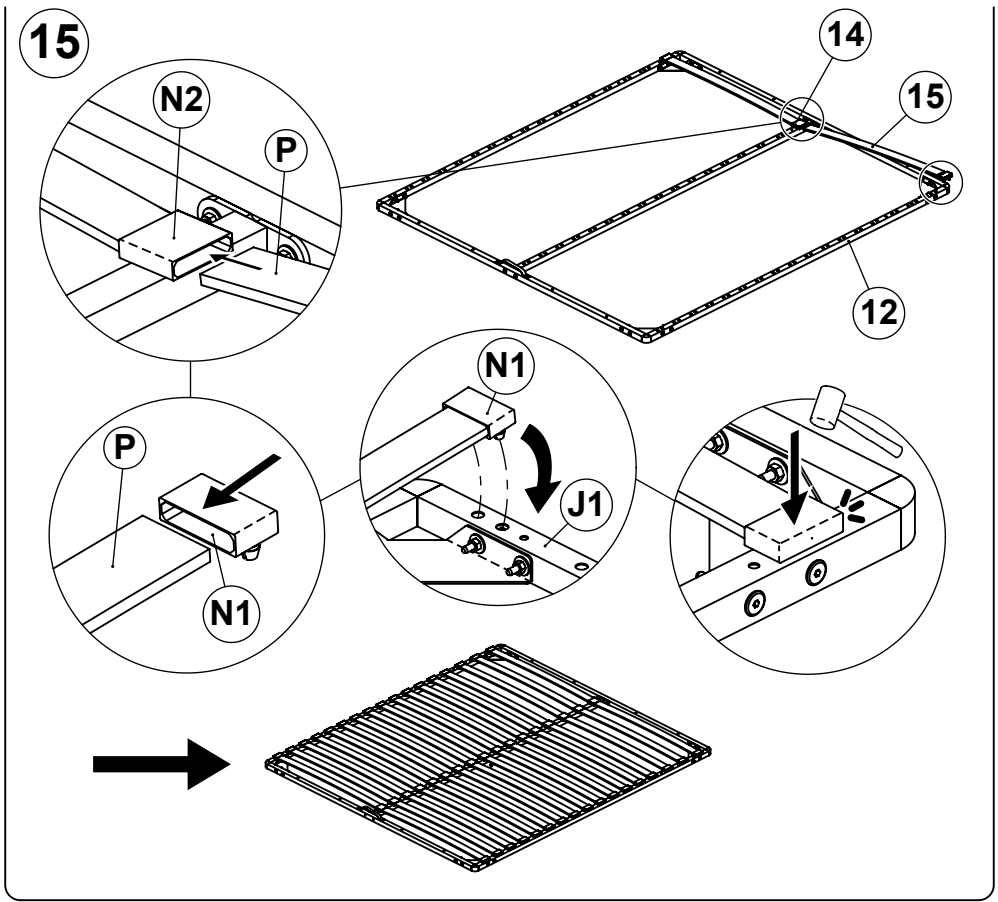

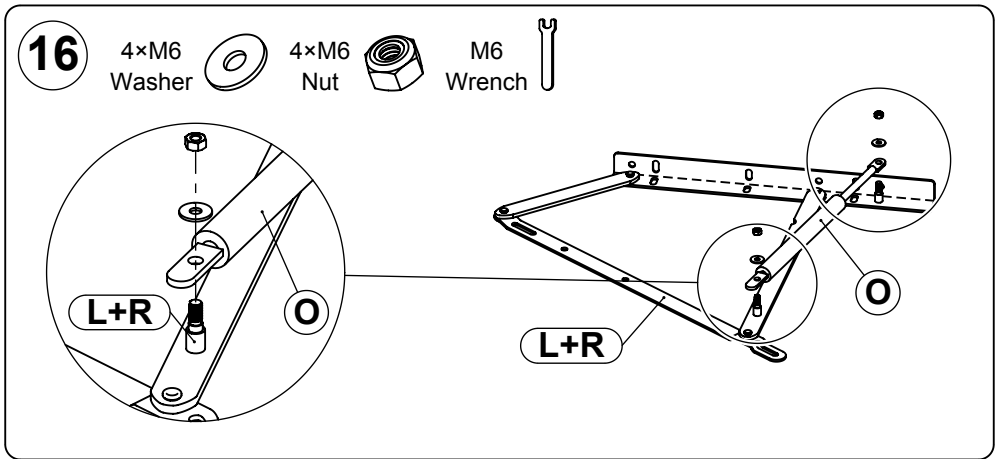

2x

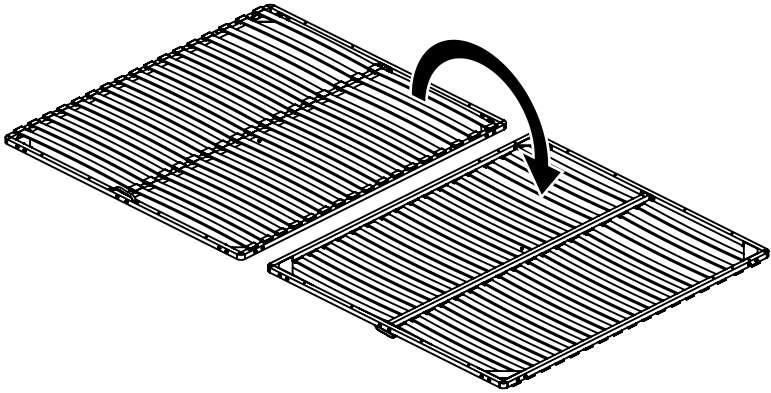

17



18 6×M6
50mm C 

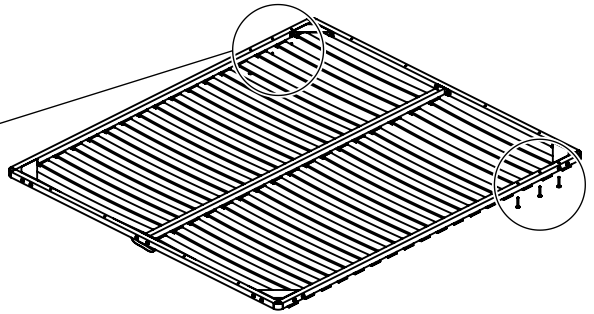
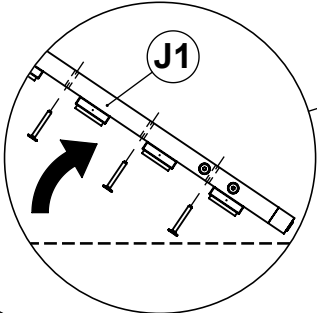

19 6×M6 Washer  6×M6 Nut 

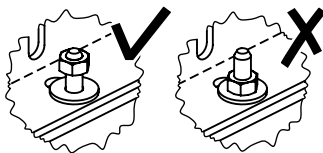
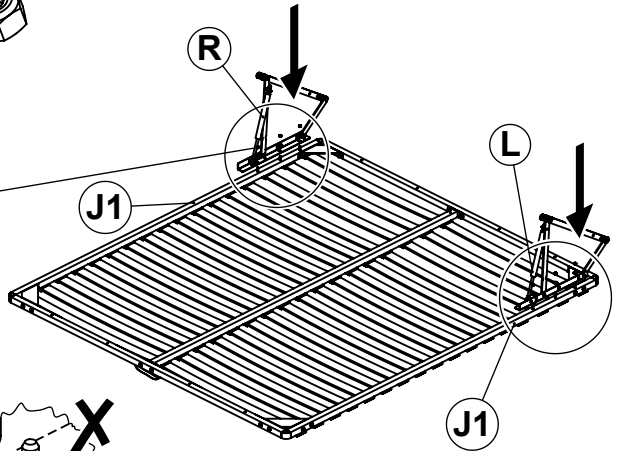
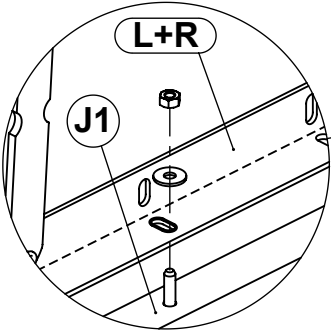

20

M6
Wrench



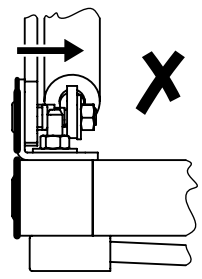
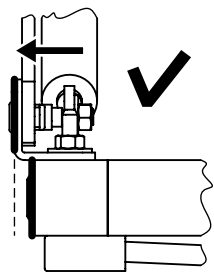
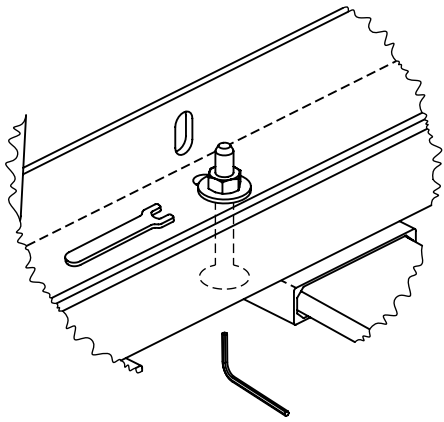

M6
Inbus

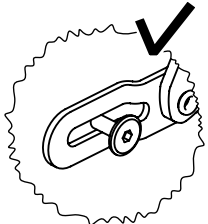
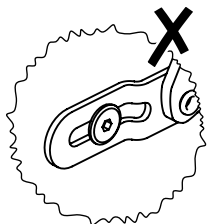
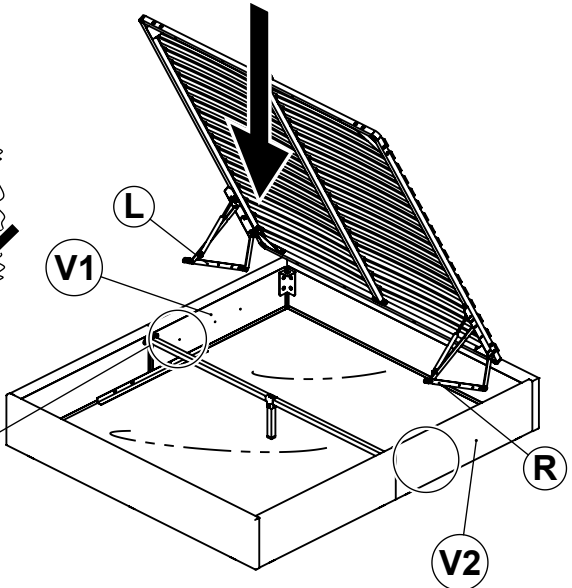
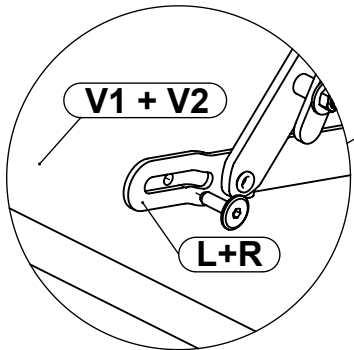
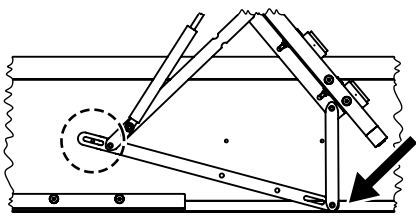

21

2×M6
20mm



22 4×M6
20mm **a** 

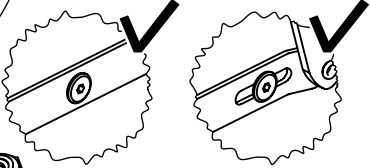
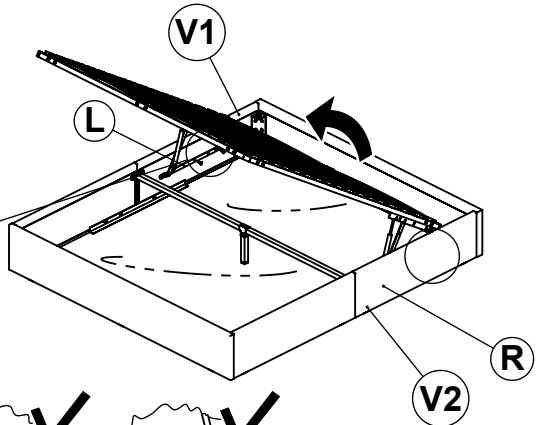
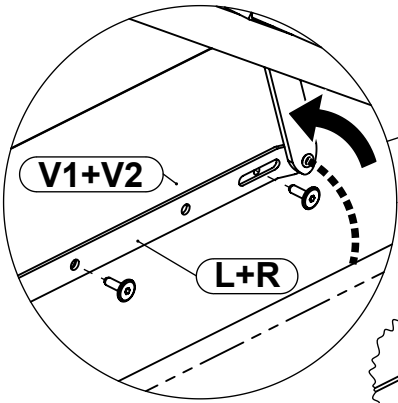

23 2×M6 Washer  2×M6 Nut 

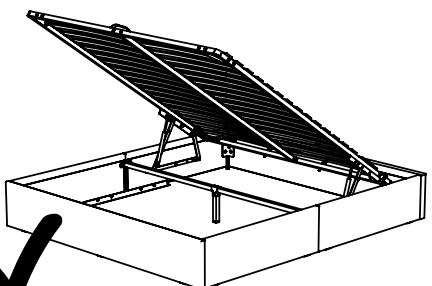
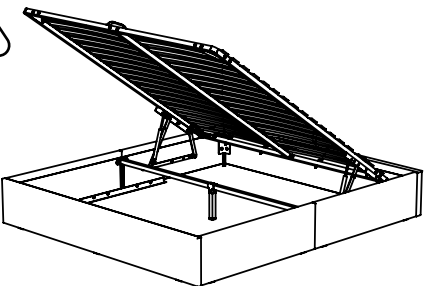
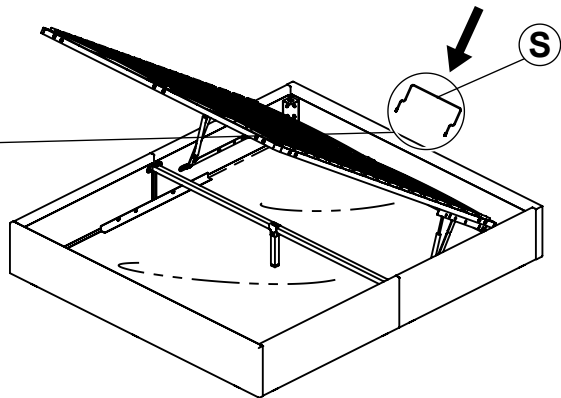
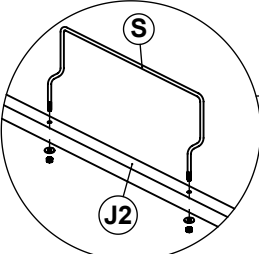

24

4×M6
60mm

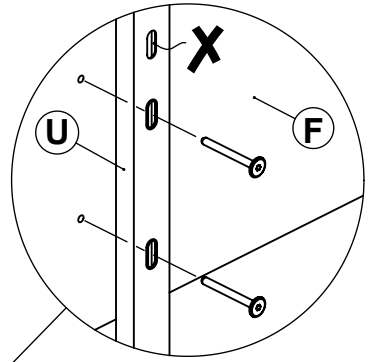
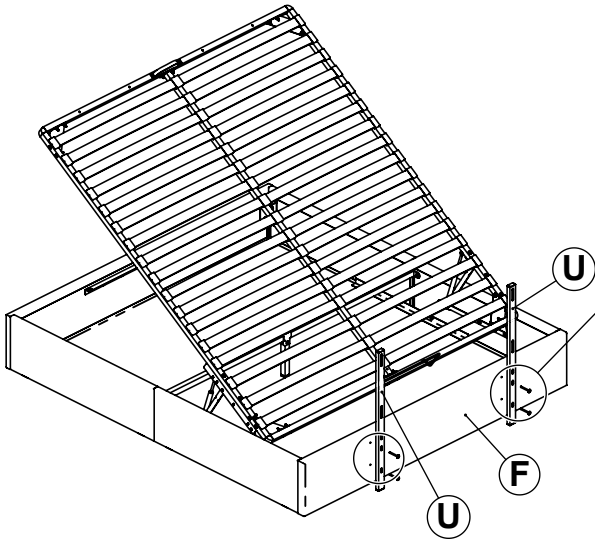

V1 + V2

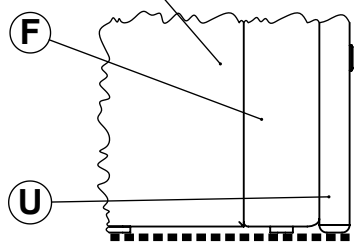

25

4×M6
40mm

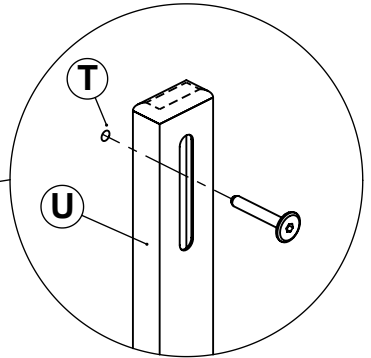
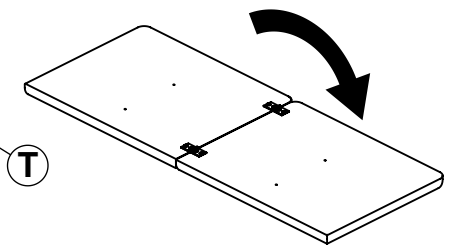
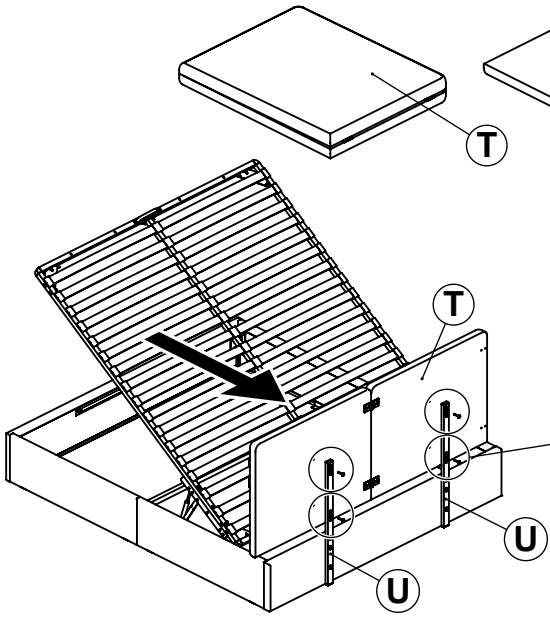

26

4×Felt
Sticker

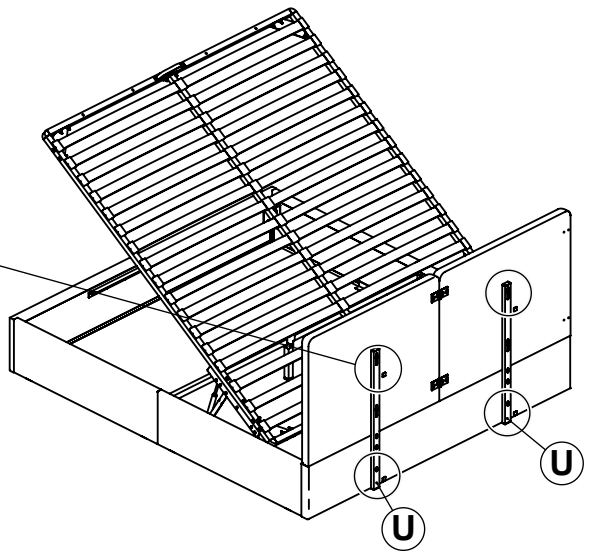
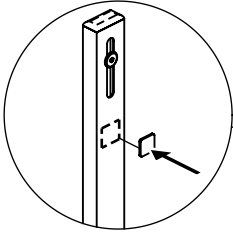

27

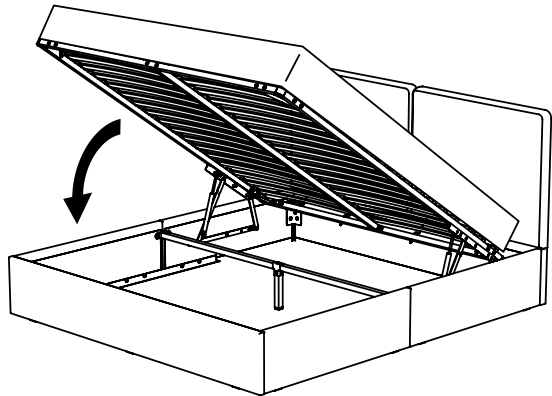
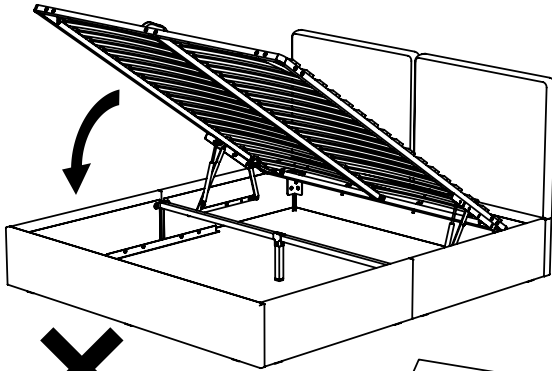



160×200 • 180×200

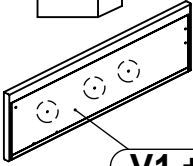

V1 + V2

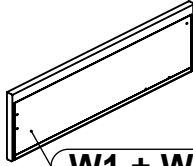

W1 + W2

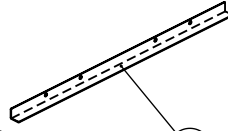

3x

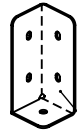

4x Y



2x E

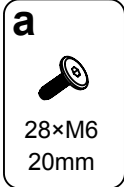

28xM6
20mm



5xM6
40mm



1xM6
Inbus



1xM6
Wrench



1xM6
Washer



1xM6
Nut



10x Felt
Sticker

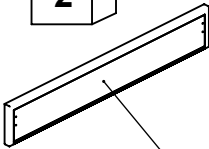

F

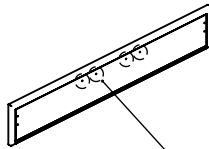

G

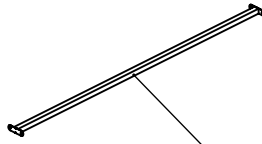

H

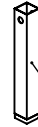

I

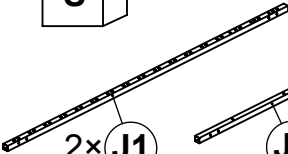

2x J1

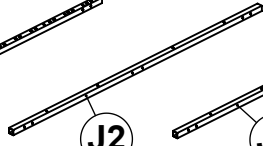

J2

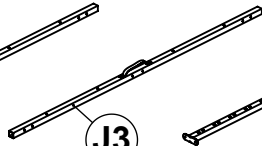

J3

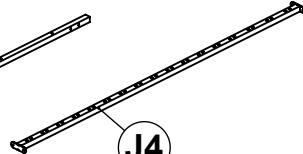

J4

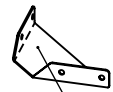

4x K

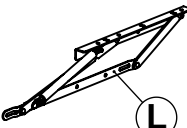

L

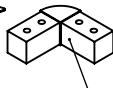

4x M



34x N1



17x N2



O

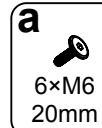

6xM6
20mm

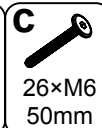

26xM6
50mm



17x P

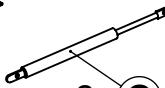

2x Q

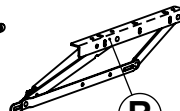

R



2x S

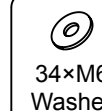

34xM6
Washer



34xM6
Nut

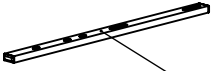
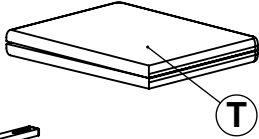

2×U

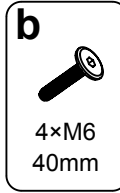

4×M6
40mm

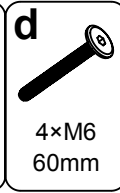

4×M6
60mm

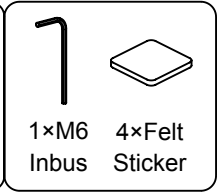

1×M6 Inbus
4×Felt Sticker

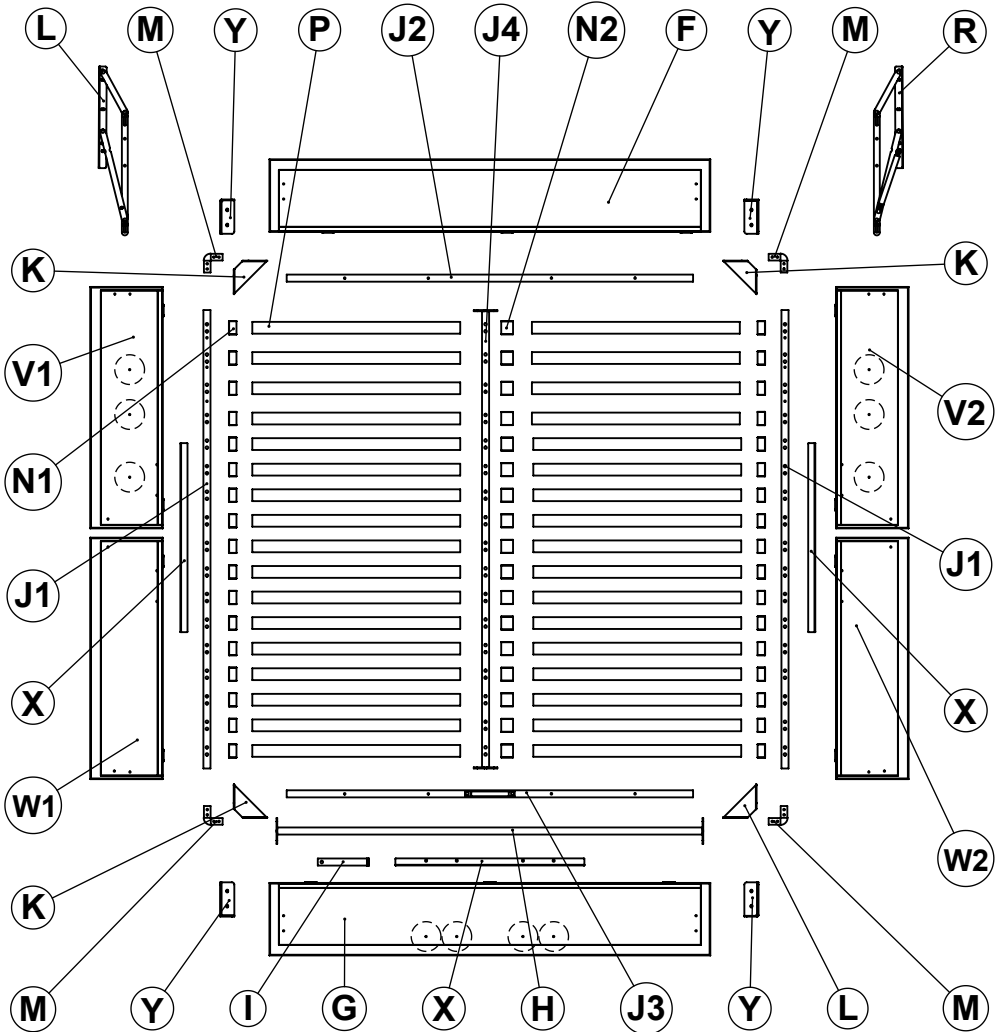

2x

1

4xM6
20mm **a**

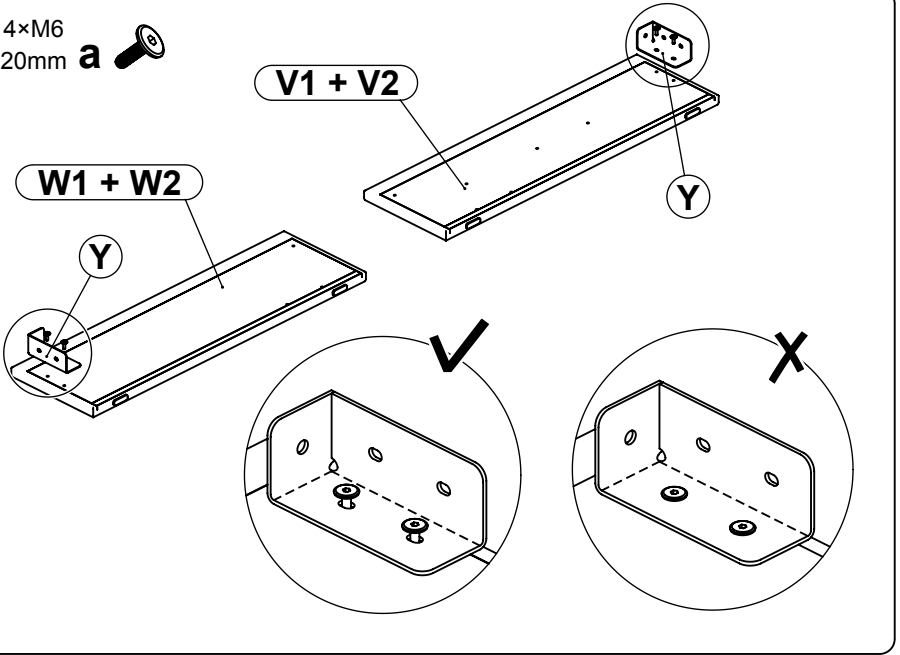

2

4xM6
20mm **a**

4xM6
40mm **b**

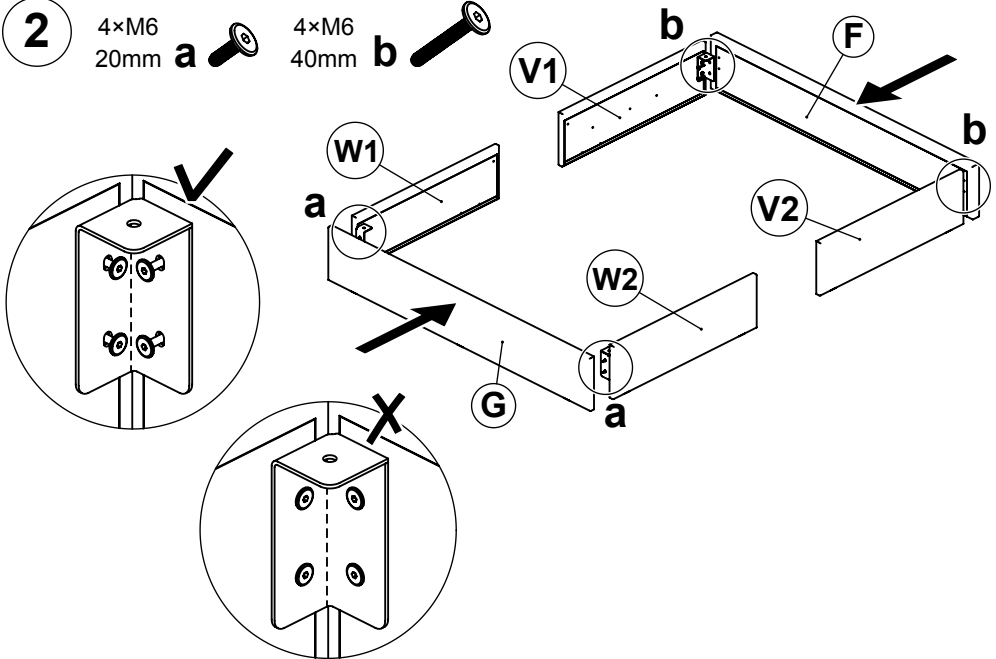

3

M6
Inbus

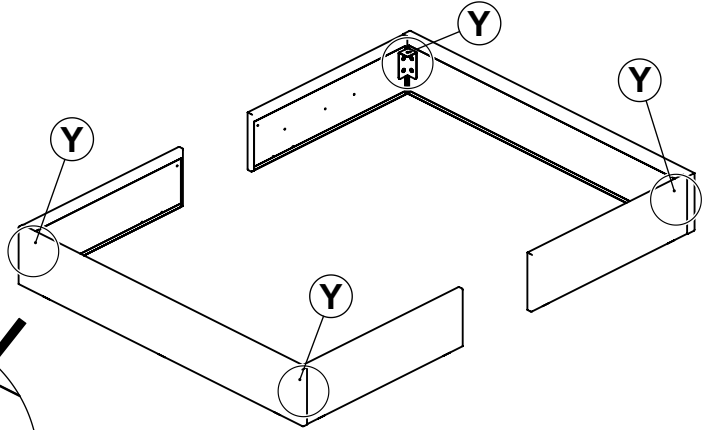
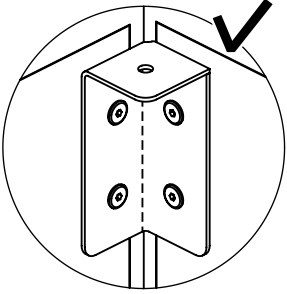
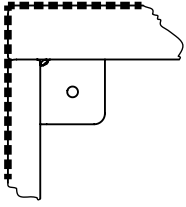

4

4×M6
20mm

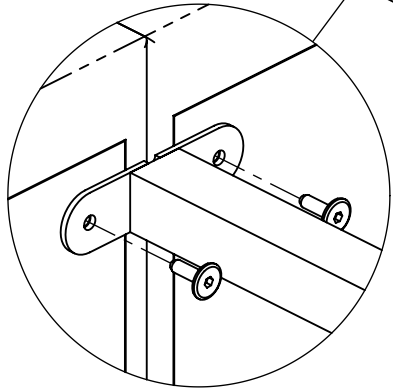
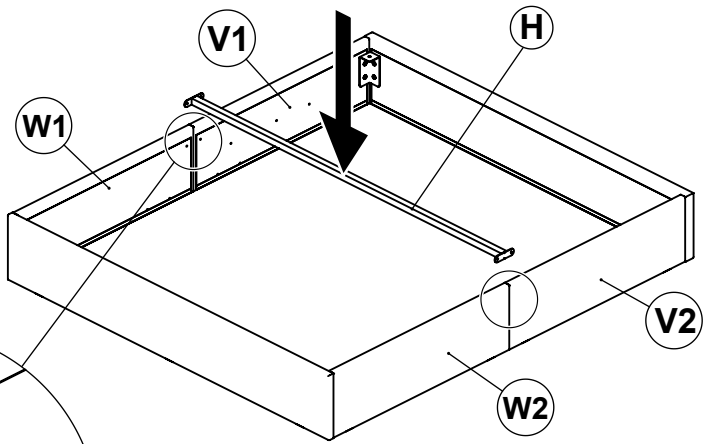

5

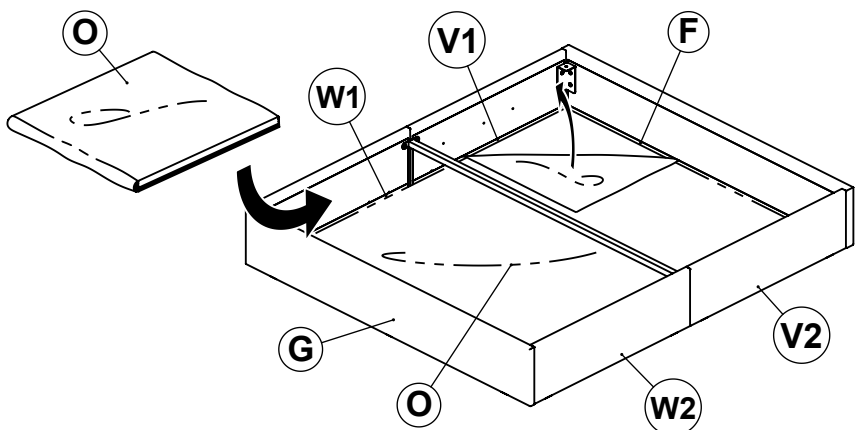

6

8×M6
20mm a 

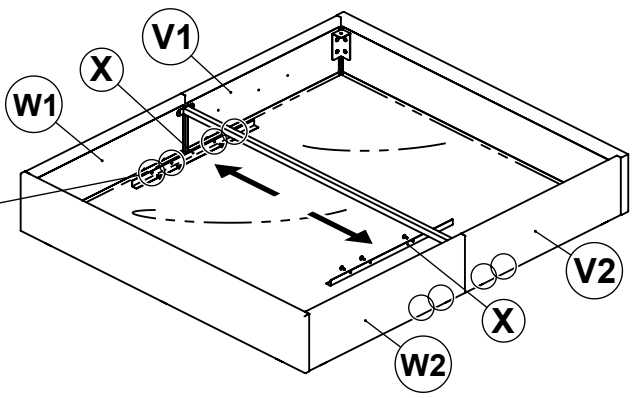
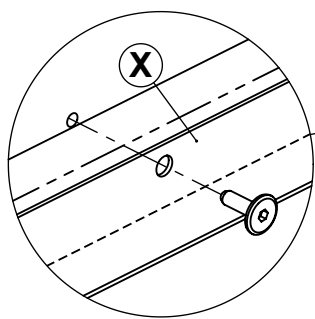

7

4×M6
20mm a 

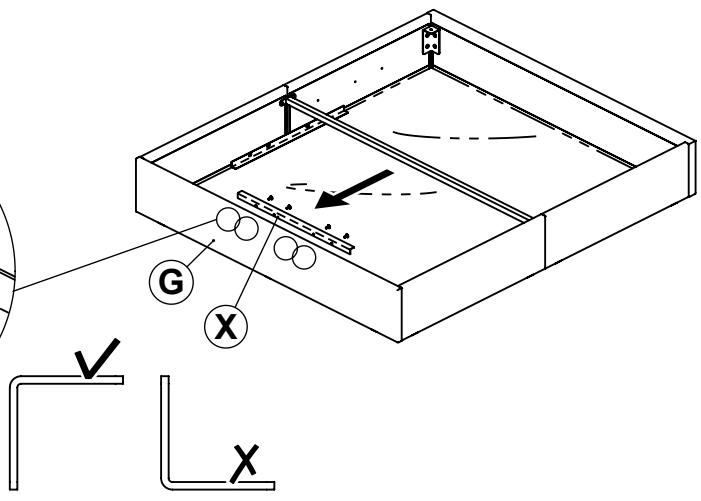
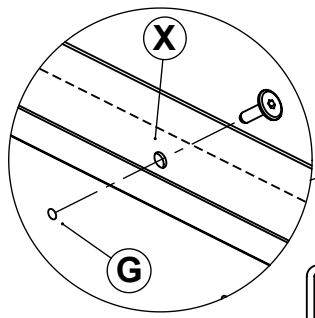

8

1×M6
40mm



1×M6
Washer



1×M6
Nut



M6
Wrench



M6
Inbus

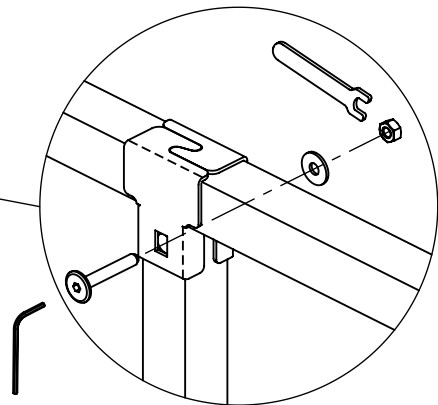
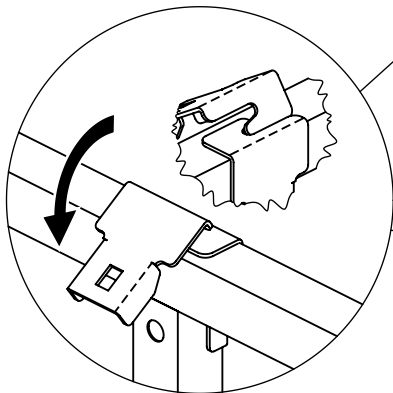
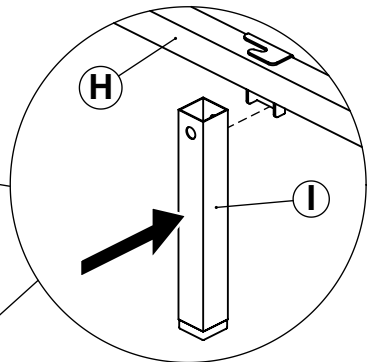
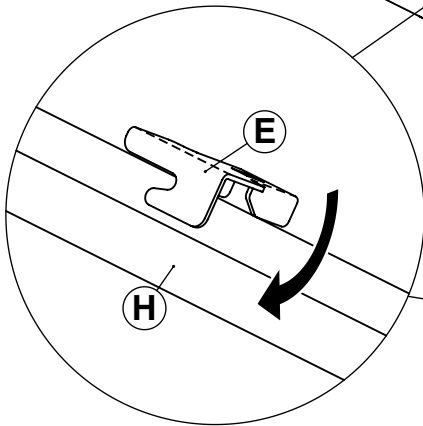
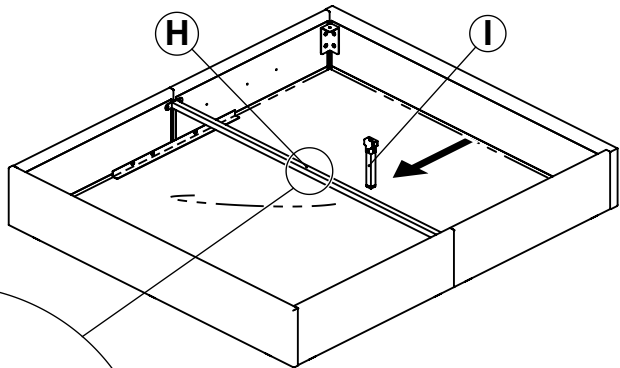

9 10×Felt
Sticker

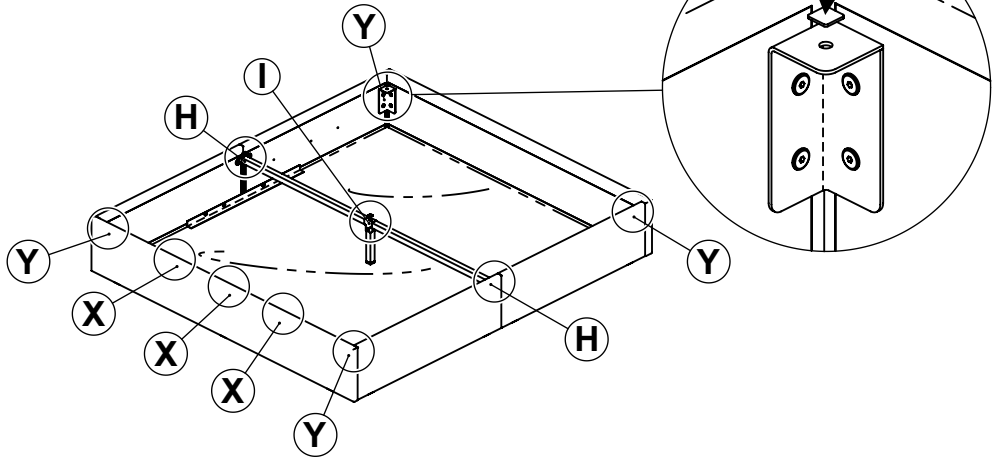
10 16×M6
50mm



16×M6
Washer

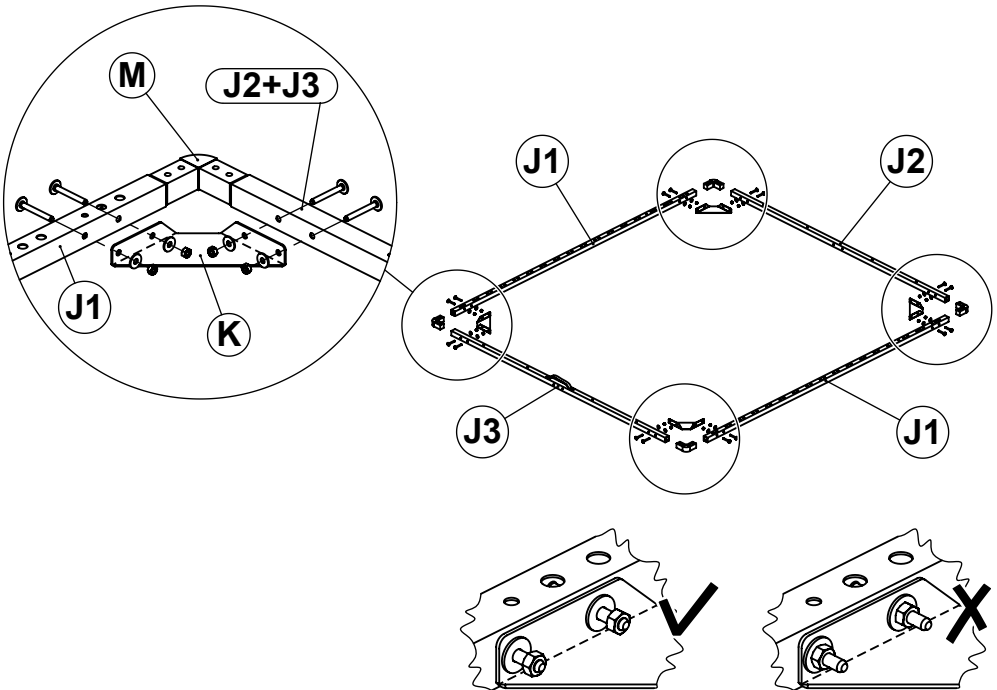

16×M6
Nut

11

4×M6
50mm



4×M6
Washer



4×M6
Nut

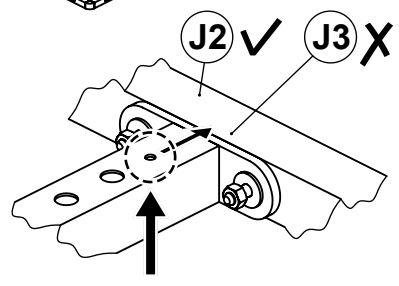
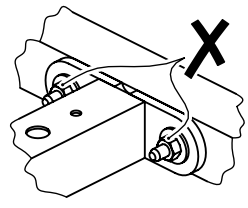
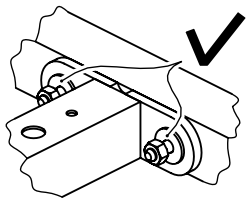
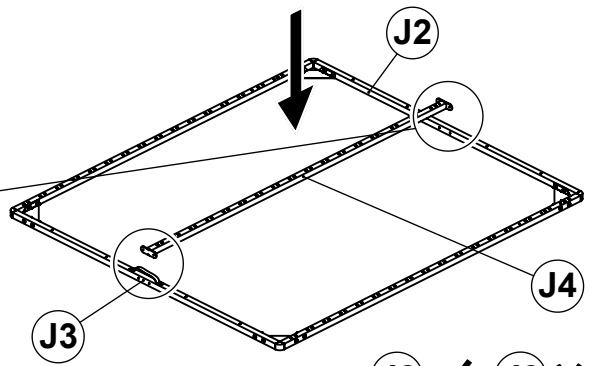
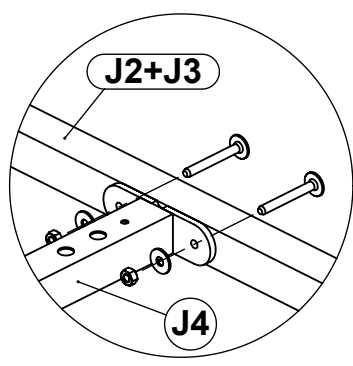

12

M6
Wrench



M6
Inbus

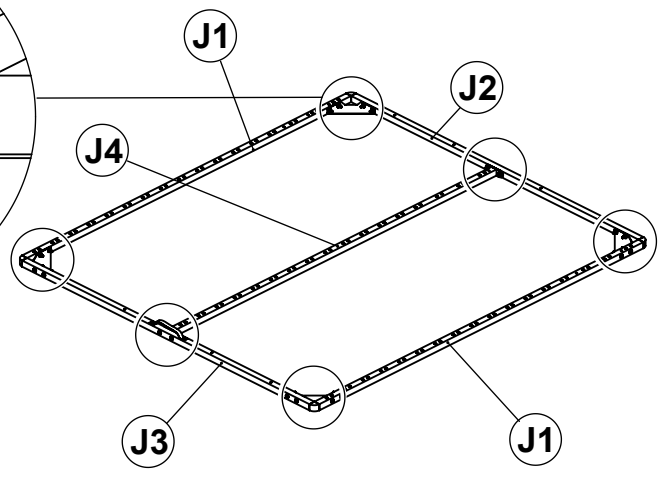
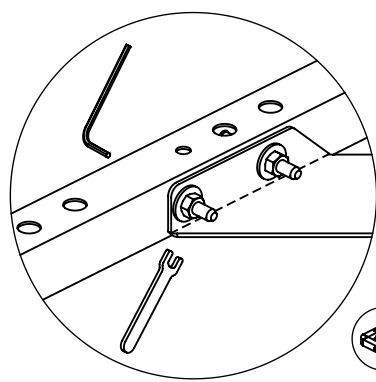

13

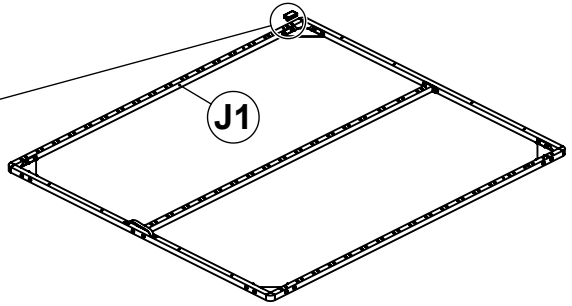
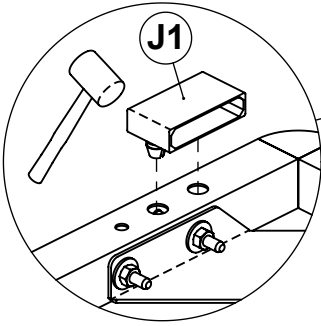

14

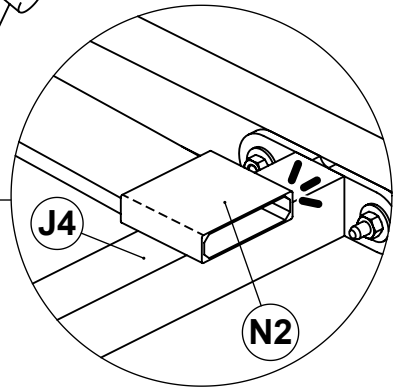
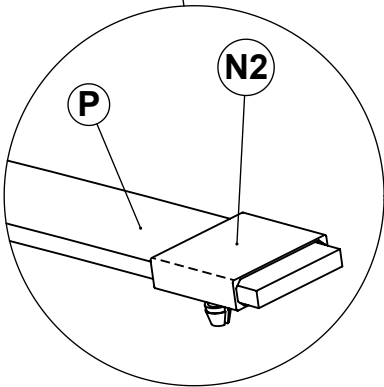
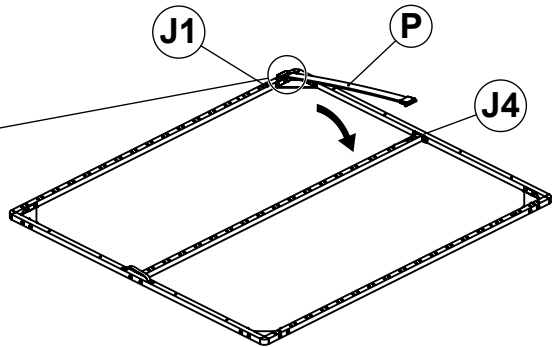
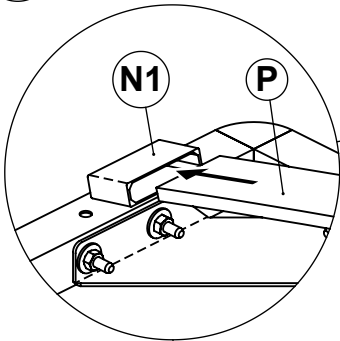

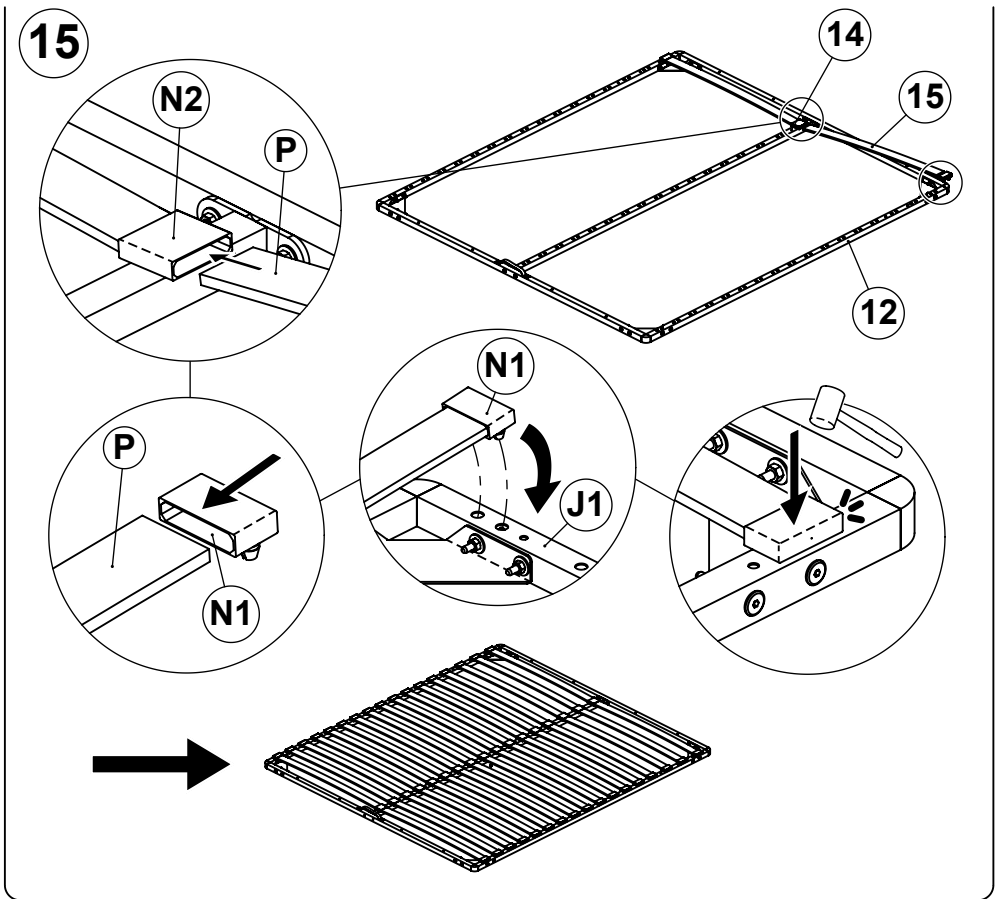

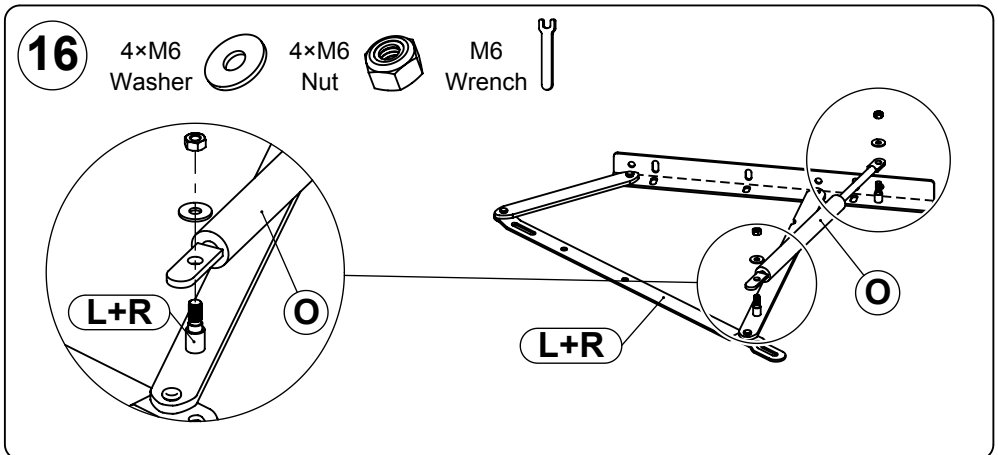

2x

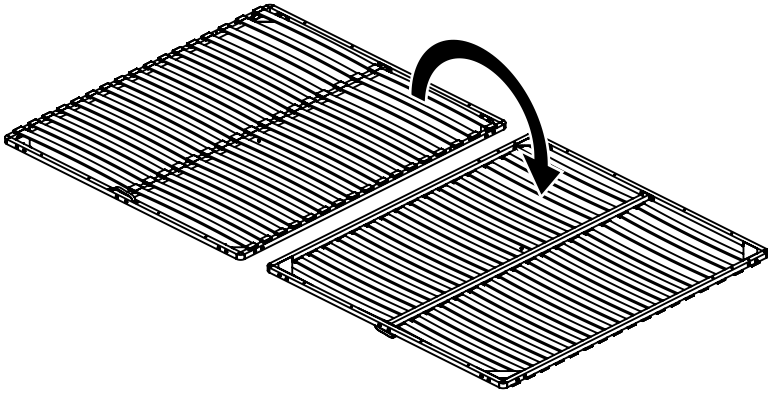

17



18 6×M6
50mm C 

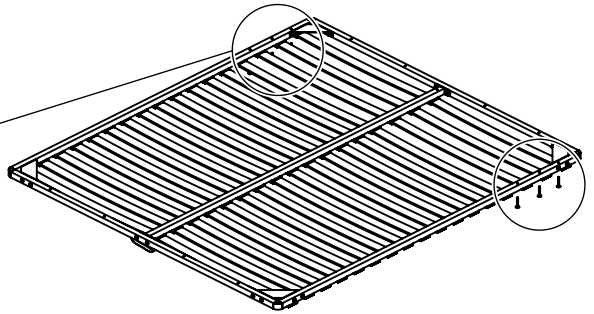
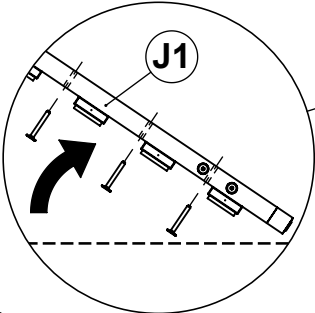

19 6×M6 Washer  6×M6 Nut 

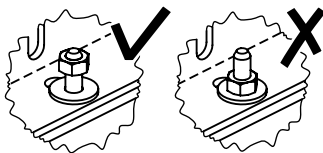
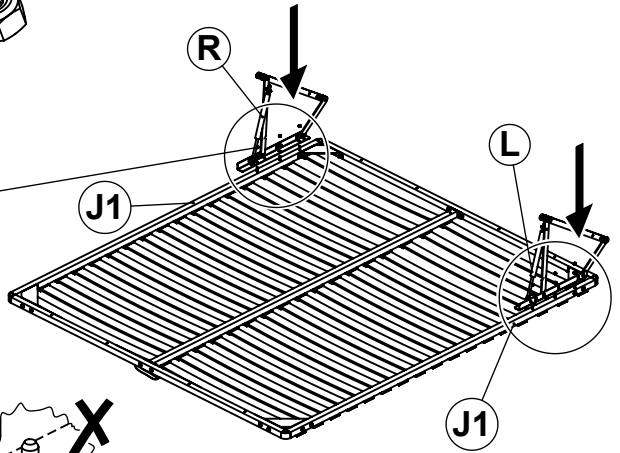
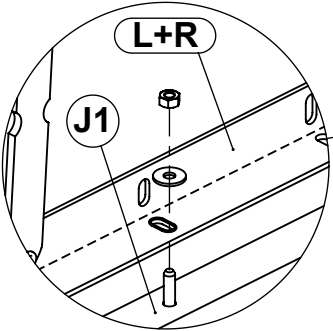

20

M6
Wrench



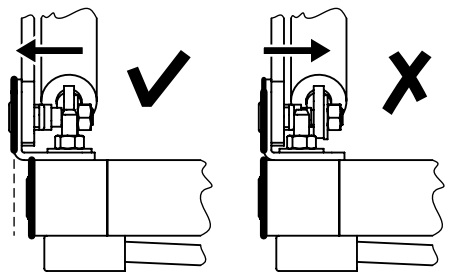
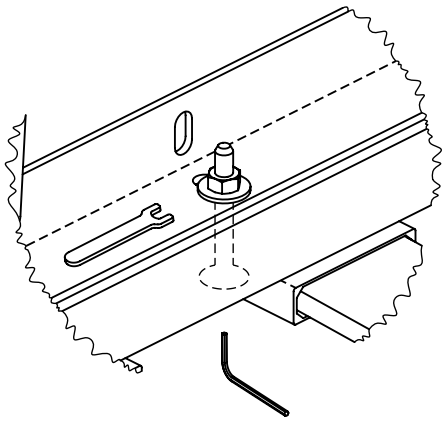

M6
Inbus

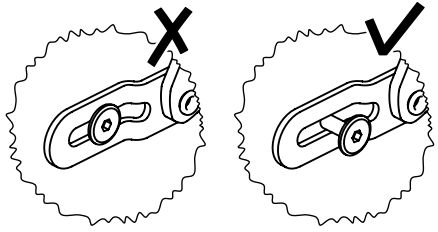
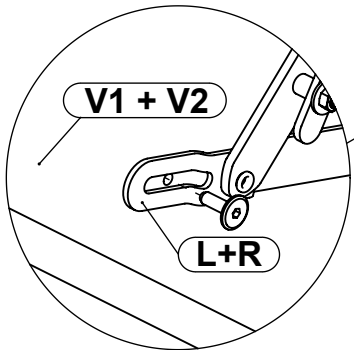
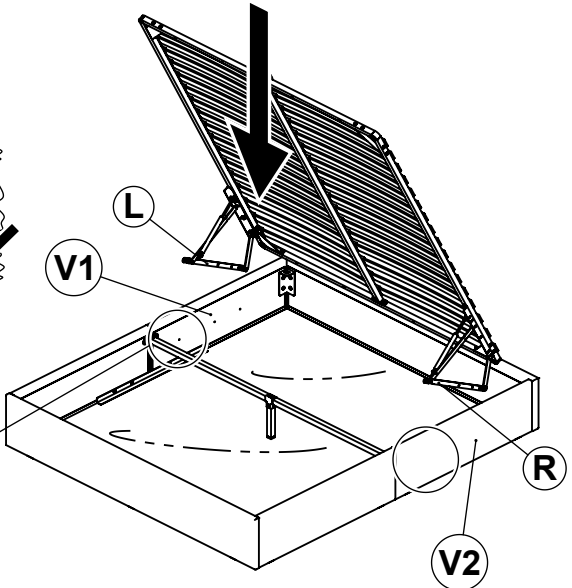
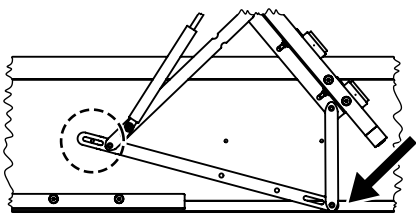

21

2×M6
20mm



22 4×M6
20mm **a** 

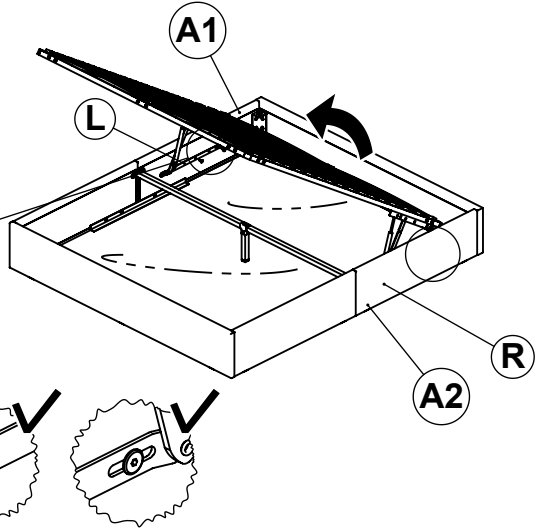
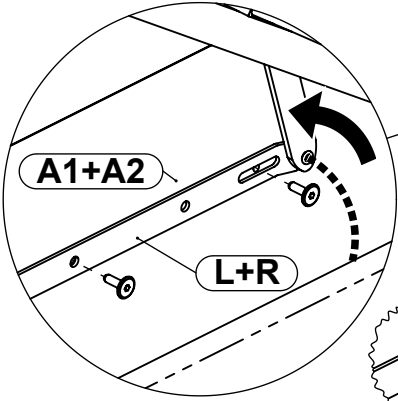

23 4×M6 Washer  4×M6 Nut 

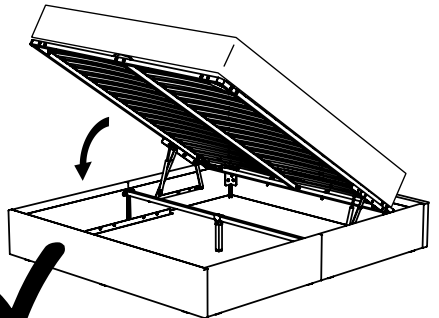
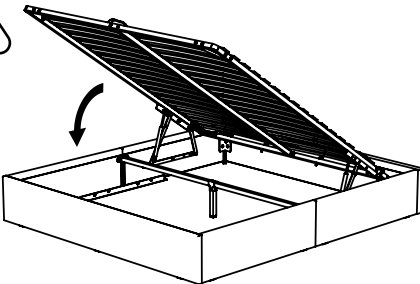
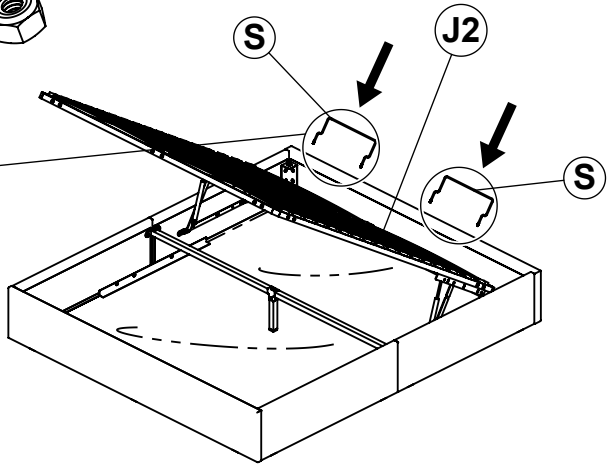
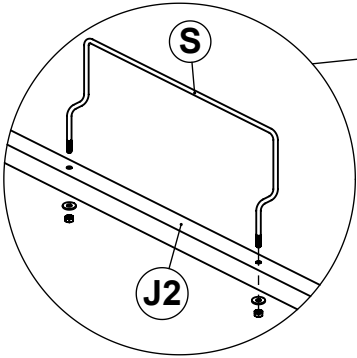

24

4×M6
60mm

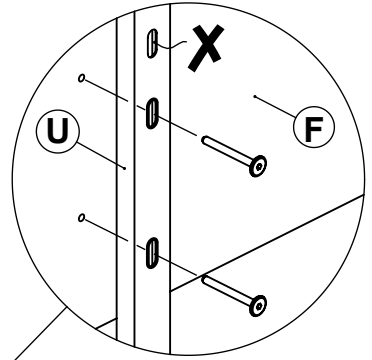
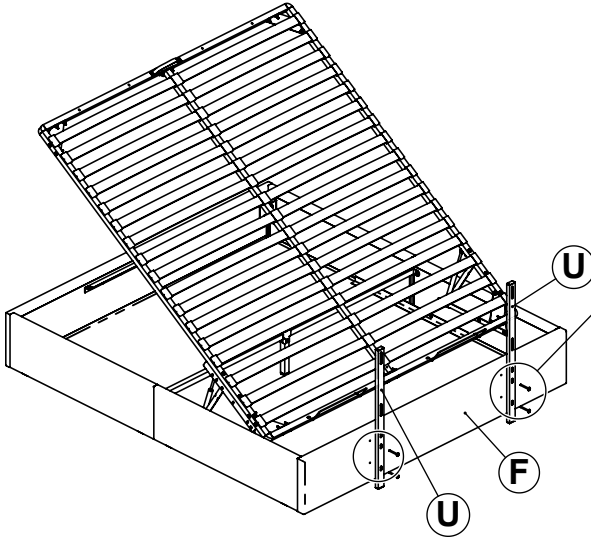

V1 + V2

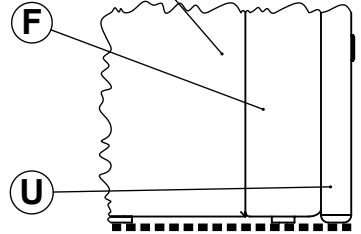

25

4×M6
40mm

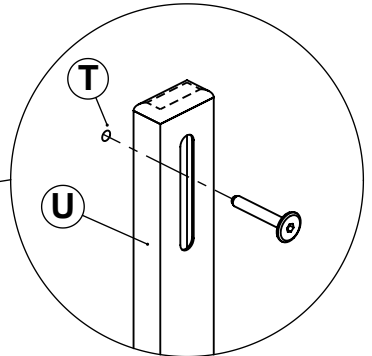
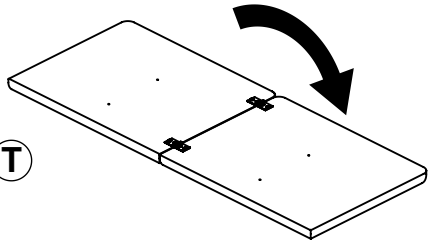
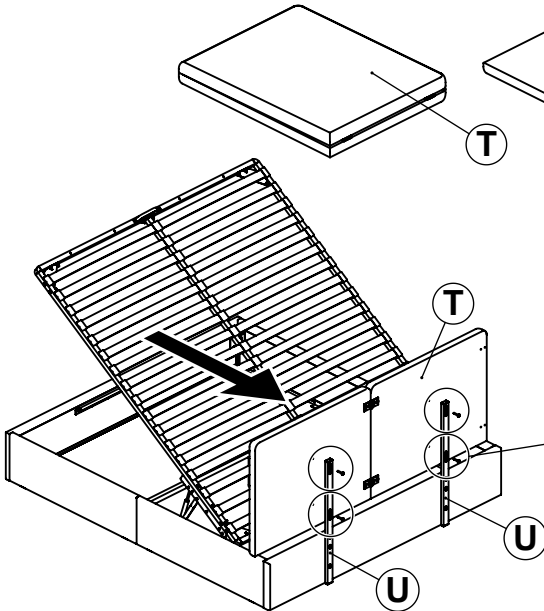

26

4×Felt
Sticker

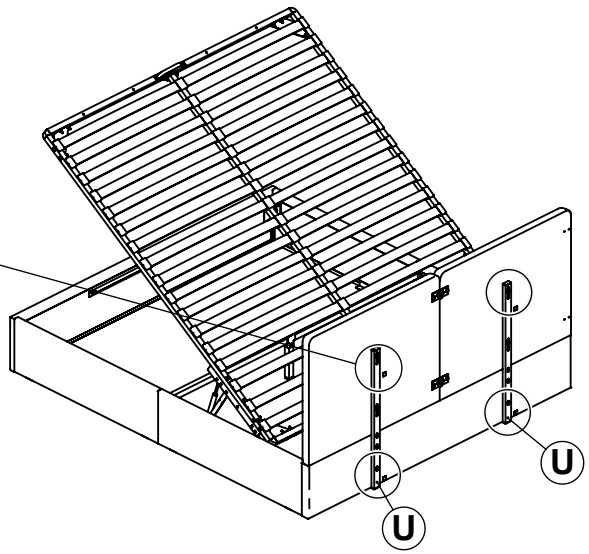
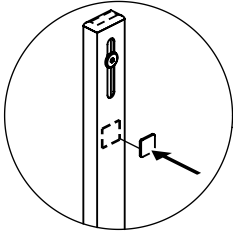

27

