

R-CJ-84-3 and R-CJR-3 3-jaw chucks



Contents

| | |
|--|----|
| Legal notices | 4 |
| Terms and conditions and warranty | 4 |
| Intended use | 4 |
| Changes to Renishaw products | 4 |
| Registration, evaluation, authorisation and restriction of chemicals (REACH) regulations | 4 |
| Packaging | 5 |
| Chuck safety | 5 |
| Cleaning | 5 |
| Specifications | 5 |
| R-CJ-84-3 3-jaw chuck | 6 |
| Installation | 6 |
| Mounting to a plate | 6 |
| Operation | 7 |
| Clamping and releasing | 7 |
| Reversing the jaws | 7 |
| Working diameters | 8 |
| Outer diameter | 8 |
| Inner diameter | 8 |
| Working heights | 9 |
| Ancillaries | 9 |
| Included with R-CJ-84-3 3-jaw chuck | 9 |
| R-CJ-84-STAND accessory | 10 |
| Mounting the R-CJ-84-3 3-jaw chuck to the stand | 10 |
| Mounting the stand | 10 |
| Working volume | 11 |
| Included with R-CJ-84-STAND accessory | 11 |

| | |
|--|----|
| R-CJR-3 3-jaw chuck | 12 |
| Mounting the chuck | 12 |
| Operation | 12 |
| Reversing the jaws | 13 |
| Clamping diameters | 13 |
| Outer diameters | 13 |
| Inner diameters | 14 |
| Working volume | 14 |
| Ancillaries | 16 |
| Included with R-CJR-3 3-jaw chuck | 16 |
| Replacement and alternative jaws and pins | 16 |
| Support | 16 |
| Further information | 16 |

Legal notices

Terms and conditions and warranty

Unless you and Renishaw have agreed and signed a separate written agreement, the equipment and/or software are sold subject to the Renishaw Standard Terms and Conditions supplied with such equipment and/or software, or available on request from your local Renishaw office.

Renishaw warrants its equipment and software for a limited period (as set out in the Standard Terms and Conditions), provided that they are installed and used exactly as defined in associated Renishaw documentation. You should consult these Standard Terms and Conditions to find out the full details of your warranty.

Equipment and/or software purchased by you from a third-party supplier is subject to separate terms and conditions supplied with such equipment and/or software. You should contact your third-party supplier for details.

Intended use

Renishaw's range of chuck fixtures are designed to hold a workpiece in a stable position, allowing it to be inspected by a Co-ordinate Measureing Machine (CMM), Equator™ gauge or vision inspection system. It must be installed, operated, and maintained as specified in Renishaw documentation and in accordance with the Standard Terms and Conditions of the Warranty and all other relevant legal requirements.

Changes to Renishaw products

Renishaw reserves the right to improve, change or modify its hardware or software without incurring any obligations to make changes to Renishaw equipment previously sold.

Registration, evaluation, authorisation and restriction of chemicals (REACH) regulations

Information required by Article 33(1) of Regulation (EC) No. 1907/2006 ("REACH") relating to products containing substances of very high concern (SVHCs) is available at www.renishaw.com/REACH.

Packaging

To aid end-user recycling and disposal, the materials used in the different components of the packaging are stated here:

| Packaging component | Material | 94/62/EC code | 94/62/EC number |
|---------------------|-------------------------------------|---------------|-----------------|
| Outer box | Cardboard | PAP | 20 |
| Inserts | Cardboard | PAP | 20 |
| Accessory packaging | High-density polyethylene bag | HDPE | 02 |
| Accessory packaging | Low-density polyethylene bubble bag | LDPE | 04 |

Chuck safety

WARNING: There are several pinch points on the Renishaw fixturing chucks. Care must be taken to keep hands clear of moving parts when opening and closing the chucks, and when clamping and removing workpieces.

Cleaning

Clean the outside faces and jaws of the chucks occasionally, using isopropyl alcohol (IPA) and a lint-free cloth to remove build-up of workshop fluids and dirt.

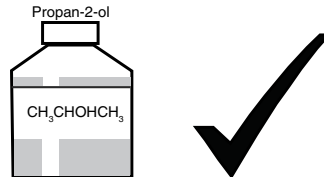

Specifications

| | R-CJ-84-3 | R-CJR-3 |
|--------------------------------|-----------------|---------------|
| Weight | 1.17 kg | 0.65 kg |
| Operating temperature | 10 °C to 40 °C | |
| Storage temperature | -25 °C to 70 °C | |
| Workpiece outer diameter range | 1 mm to 102 mm | 1 mm to 57 mm |
| Workpiece inner diameter range | 7 mm to 105 mm | 8 mm to 63 mm |

R-CJ-84-3 3-jaw chuck

Installation

The R-CJ-84-3 3-jaw chuck can be mounted on any Renishaw modular fixturing plate. The 3-jaw chuck features locating slots for each standard thread type.

The R-CJ-84-STAND accessory mounts the chuck with a horizontal clamping axis.

Mounting to a plate

The chuck is mounted using two screws and comes supplied with fixings to attach it directly to M4, M6, M8 and 1/4-20 UNC fixturing plates.

The alignment screw prevents the chuck from rotating when mounted. The screw is screwed directly onto the plate and the relevant slot in the back of the chuck is located over it. Always use the cap head screw provided.

The mounting screw locates through the centre hole of the chuck. Washers are required for the M6, 1/4-20 UNC and M4 options. For the M4 thread type, use the button head screw provided.

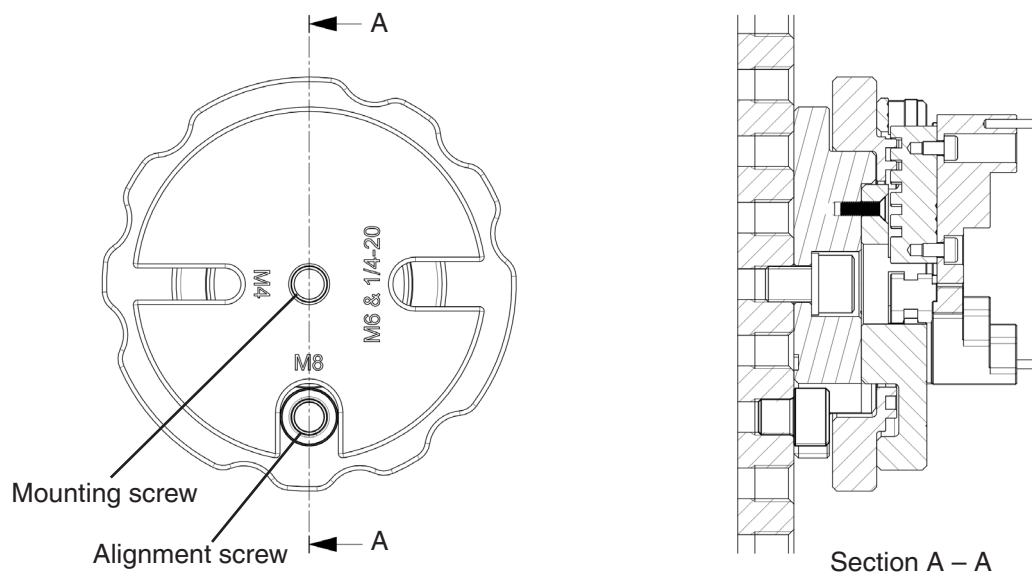

NOTE: The thread sizes are marked on the rear of the chuck. The plate has been removed in the first image for illustrative purposes.

Operation

Clamping and releasing

Hold the workpiece in the correct position and turn the clamping wheel anticlockwise (when viewed from the front) to clamp an outer diameter. The supplied tightening tools can be screwed into the threaded holes on the clamping wheel to aid clamping.

To release, hold onto the workpiece while turning the clamping wheel in the reverse direction.

Reversing the jaws

The jaws can be removed using a 2.5 mm hex key and reversed to switch between clamping outside diameters and inside diameters.

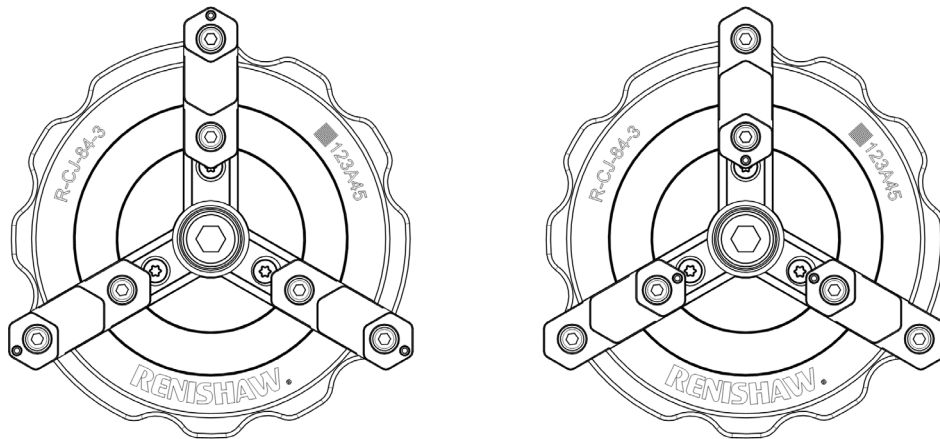

Working diameters

Outer diameter

| Position | Minimum (mm) | Maximum (mm) | Diameter minimum (mm) | Diameter maximum (mm) |
|----------------|--------------|--------------|-----------------------|-----------------------|
| O ₁ | 0.5 | 16.0 | 1.0 | 32.0 |
| O ₂ | 13.0 | 28.5 | 26.0 | 57.0 |
| O ₃ | 25.5 | 41.0 | 51.0 | 82.0 |
| O ₄ | 35.5 | 51.0 | 71.0 | 102.0 |

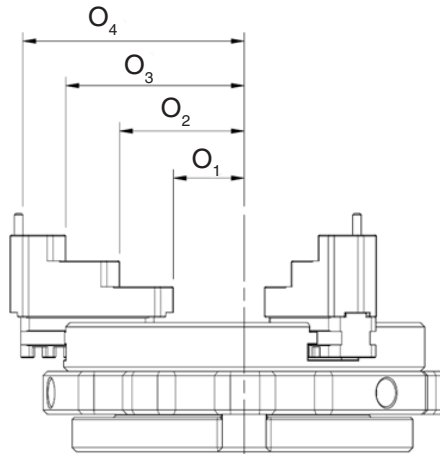

Inner diameter

| Position | Minimum (mm) | Maximum (mm) | Diameter minimum (mm) | Diameter maximum (mm) |
|----------------|--------------|--------------|-----------------------|-----------------------|
| I ₁ | 3.5 | 19.0 | 7.0 | 38.0 |
| I ₂ | 13.5 | 29.0 | 27.0 | 58.0 |
| I ₃ | 26.0 | 41.5 | 52.0 | 83.0 |
| I ₄ | 38.5 | 52.5 | 77.0 | 105.0 |

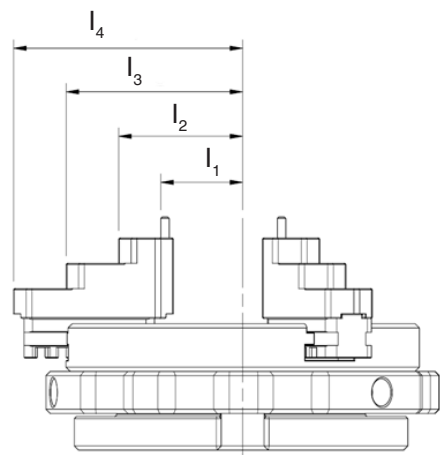

Working heights

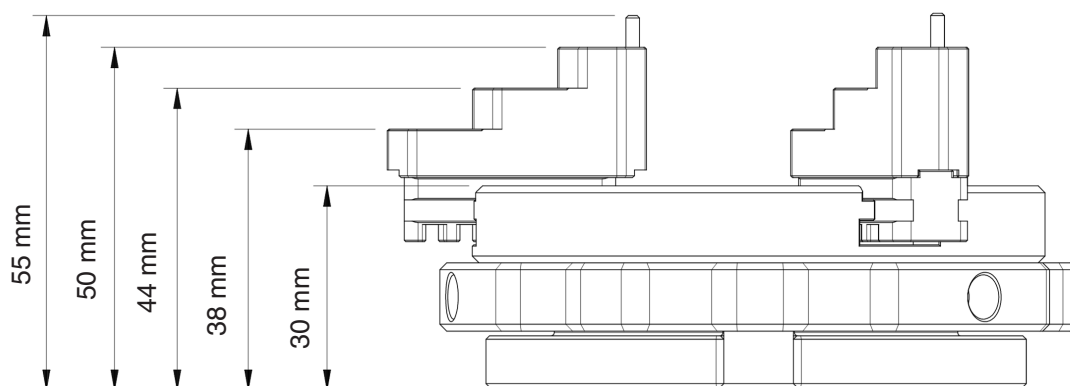

Ancillaries

Included with R-CJ-84-3 3-jaw chuck

| Description | Quantity | Use |
|---|----------|--------------------|
| M4 × 4 mm cap head screw (black) | 1 | Aligning the chuck |
| M4 × 10 mm button screw (black) | 1 | Mounting the chuck |
| M4 oversized washer (black) | 2 | Mounting the chuck |
| M6 × 6 mm cap head screw (black) | 1 | Aligning the chuck |
| M6 × 12 mm cap head screw (black) | 1 | Mounting the chuck |
| M6/1/4 20 oversized washer (black) | 2 | Mounting the chuck |
| 1/4-20 UNC × 1/4 in cap head screw (silver) | 1 | Aligning the chuck |
| 1/4-20 UNC × 7/16 in 20 cap head screw (silver) | 1 | Mounting the chuck |
| M8 × 8 mm cap head screw (black) | 1 | Aligning the chuck |
| M8 × 12 mm cap head screw (black) | 1 | Mounting the chuck |
| M8 washer (black) | 2 | Mounting the chuck |
| Ø2 × 12 mm pins | 6 | |
| Tightening tool | 2 | |

R-CJ-84-STAND accessory

Mounting the R-CJ-84-3 3-jaw chuck to the stand

When mounting the chuck to the stand accessory, an M8 screw is used through the central hole of the chuck. The chuck alignment is set by locating the pre-installed M8 cap head screw in the relevant locating slot.

Mounting the stand

The stand can be mounted to any Renishaw fixturing plate using the hole and slot features in the base.

Using the correct washer (supplied) for the required thread type, screw through the hole to locate the stand on the plate, and then through the slot to fully attach to the plate.

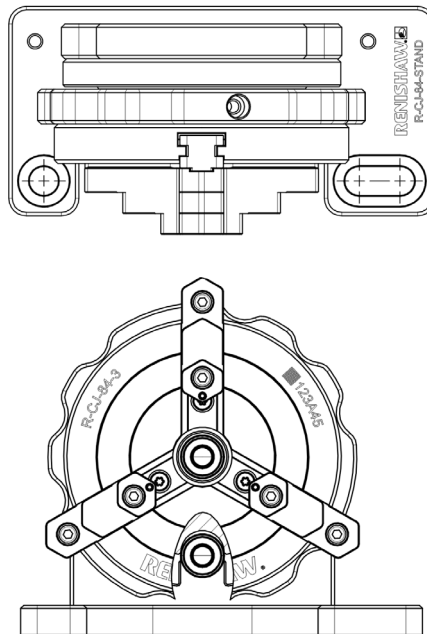

Working volume

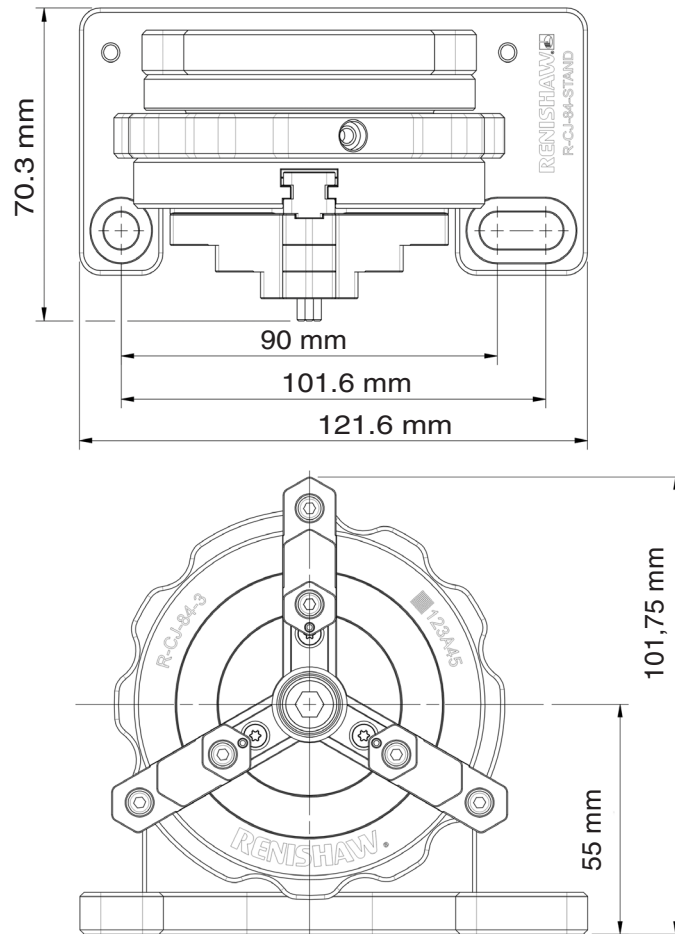

Included with R-CJ-84-STAND accessory

| Description | Quantity | Use |
|--|----------|---|
| M4 × 10 mm button screw (black) | 2 | Mounting the stand |
| M4 oversized washer (black) | 4 | Mounting the stand |
| M6 × 12 mm socket screw (black) | 2 | Mounting the stand |
| M6/1/4-20 UNC oversized washer (black) | 4 | Mounting the stand |
| M8 × 12 mm cap head screw (black) | 3 | Mounting the chuck to the stand [1] Mounting the stand [2] |
| M8 washer (black) | 4 | Mounting the stand |
| 1/4-20 UNC × 7/6 in cap head (silver) | 2 | Mounting the stand |

R-CJR-3 3-jaw chuck

The R-CJR-3 3-jaw chuck is a 50 mm diameter chuck integrated into a stand. The stand allows the workpiece to be indexed without being removed from the chuck.

Mounting the chuck

The chuck body has mounting features that allow the chuck to be operated in either a vertical or horizontal orientation. The chuck can be mounted to any Renishaw fixturing plate using the supplied screws and washers.

Operation

Ensure the thumbscrew is loose so that the chuck can rotate freely.

Place the workpiece between the jaws and tighten using the clamping wheel. If additional torque is required, use the supplied tightening tools, one in the front face of the chuck and one in the clamping wheel.

The chuck can be rotated within the stand, with the rotation being tracked using the angle reading on the top of the main body. Tighten the thumbscrew once positioning is complete.

To release, hold onto the workpiece and then turn the clamping wheel in the reverse direction.

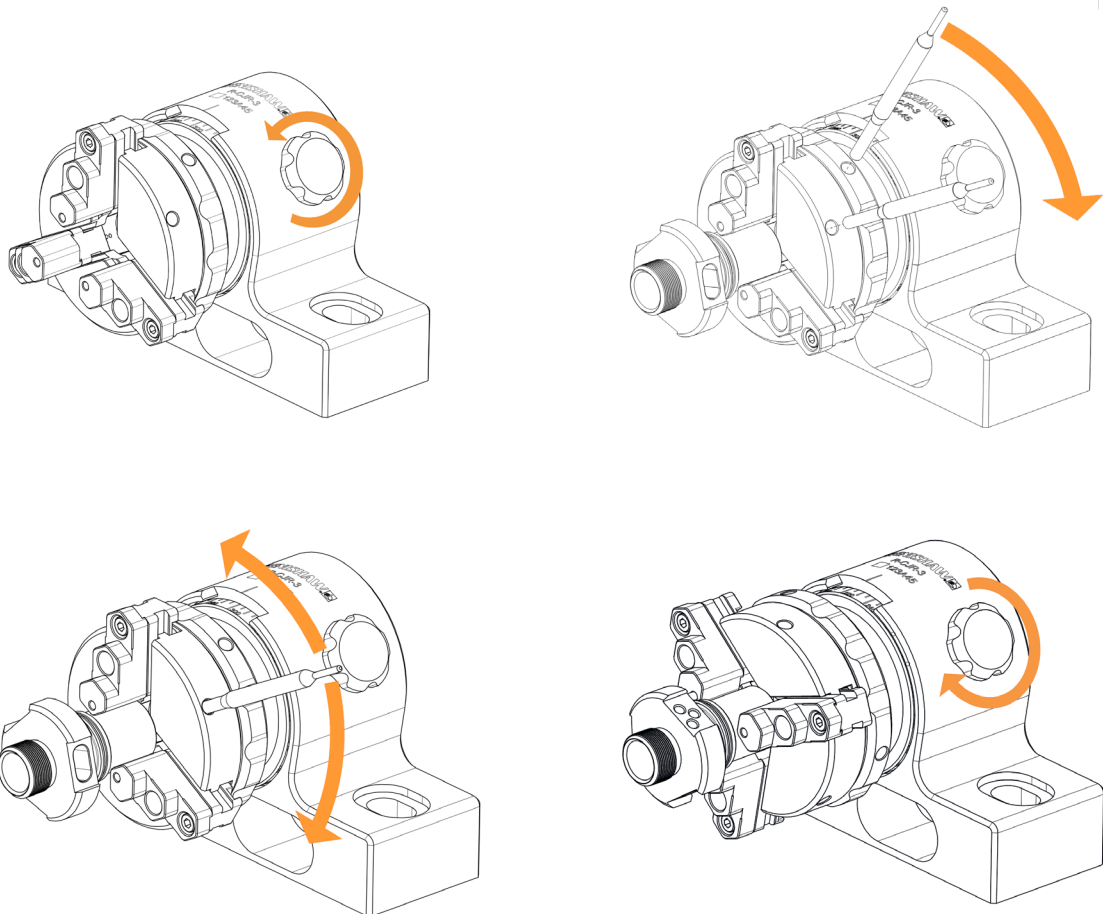

Reversing the jaws

The jaws can be removed using a 3 mm hex key (not provided) and reversed to switch between clamping outside diameters and inside diameters.

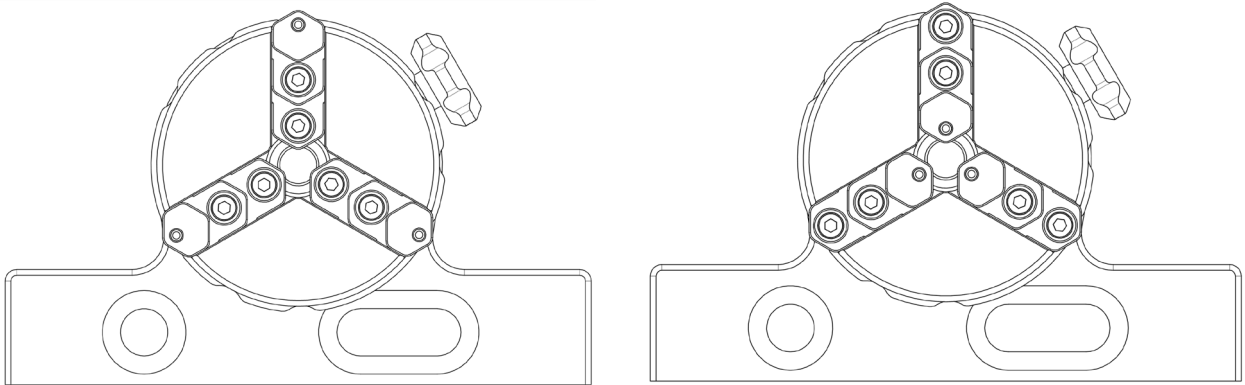

Clamping diameters

Outer diameters

| Position | Minimum (mm) | Maximum (mm) | Diameter minimum (mm) | Diameter maximum (mm) |
|----------------|--------------|--------------|-----------------------|-----------------------|
| O ₁ | 0.5 | 8.0 | 1.0 | 16.0 |
| O ₂ | 8.0 | 15.5 | 16.0 | 31.0 |
| O ₃ | 15.5 | 23.0 | 31.0 | 46.0 |
| O ₄ | 21.0 | 28.5 | 42.0 | 57.0 |

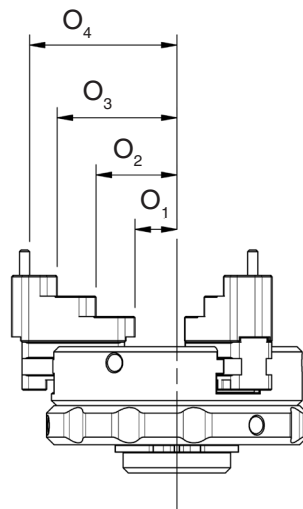

Inner diameters

| Position | Minimum (mm) | Maximum (mm) | Diameter minimum (mm) | Diameter maximum (mm) |
|----------|--------------|--------------|-----------------------|-----------------------|
| l_1 | 4.0 | 11.5 | 8.0 | 23.0 |
| l_2 | 9.5 | 17.0 | 19.0 | 34.0 |
| l_3 | 17.0 | 24.5 | 34.0 | 49.0 |
| l_4 | 24.5 | 31.5 | 49.0 | 63.0 |

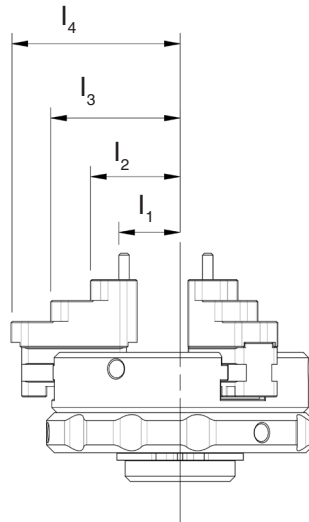

Working volume

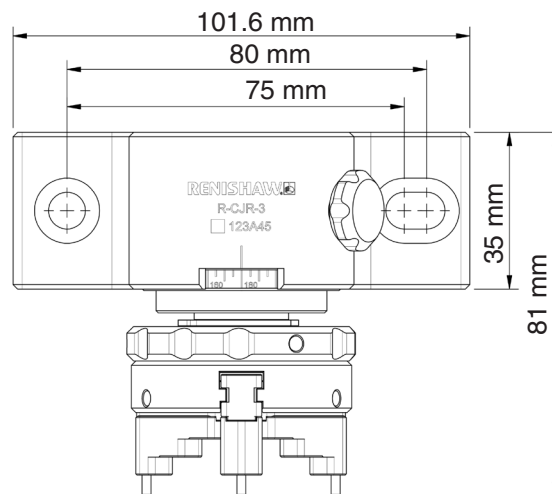

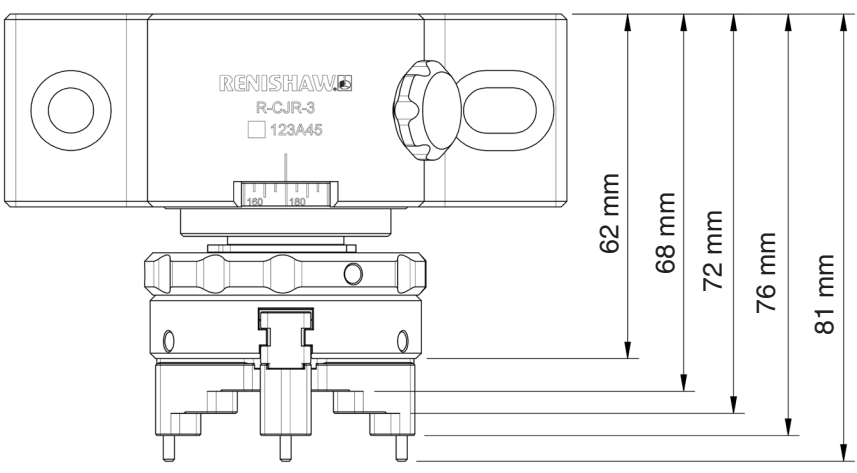
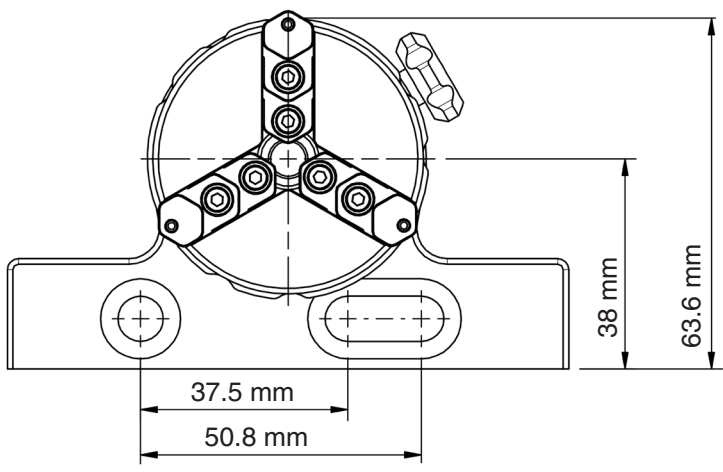

Ancillaries

Included with R-CJR-3 3-jaw chuck

| Description | Quantity |
|---|----------|
| M4 × 22 mm button screw (black) | 4 |
| M4 oversized washer (black) | 4 |
| M6 × 25 mm cap head screw (black) | 4 |
| M6/1/4-20 UNC oversized washer (black) | 4 |
| M8 × 25 mm cap head screw (black) | 4 |
| M8 washer (black) | 4 |
| 1/4-20 UNC × 1 in cap head screw (silver) | 4 |
| Ø2 × 12 mm pins | 6 |
| Tightening tool | 2 |

Replacement and alternative jaws and pins

Replacement jaws are available in different materials for both the R-CJ-84-3 and R-CJR-3 3-jaw chucks. Replacement jaws are sold as packs of three, and pins as packs of nine.

| Part number | Description |
|--------------|---------------------------------|
| R-CJ-84-SJAW | Stainless steel CJ jaws |
| R-CJ-84-AJAW | Aluminium CJ jaws (standard) |
| R-CJR-SJAW | Stainless steel CJR jaws |
| R-CJR-AJAW | Aluminium CJR jaws (standard) |
| R-PINS-2 | Stainless steel Ø2 × 12 mm pins |





Support

Further information

Further information relating to chucks is available from your local Renishaw representative.

www.renishaw.com/contact

 #renishaw

UK  +44 (0) 1453 524524  uk@renishaw.com **USA**  +1 847 286 9953  usa@renishaw.com

© 2026 Renishaw plc. All rights reserved. This document may not be copied or reproduced in whole or in part, or transferred to any other media or language by any means, without the prior written permission of Renishaw.

RENISHAW® and the probe symbol are registered trade marks of Renishaw plc. Renishaw product names, designations and the mark 'apply innovation' are trade marks of Renishaw plc or its subsidiaries. Other brand, product or company names are trade marks of their respective owners.

WHILE CONSIDERABLE EFFORT WAS MADE TO VERIFY THE ACCURACY OF THIS DOCUMENT AT PUBLICATION, ALL WARRANTIES, CONDITIONS, REPRESENTATIONS AND LIABILITY, HOWSOEVER ARISING, ARE EXCLUDED TO THE EXTENT PERMITTED BY LAW. RENISHAW RESERVES THE RIGHT TO MAKE CHANGES TO THIS DOCUMENT AND TO THE EQUIPMENT, AND/OR SOFTWARE AND THE SPECIFICATION DESCRIBED HEREIN WITHOUT OBLIGATION TO PROVIDE NOTICE OF SUCH CHANGES.

Renishaw plc. Registered in England and Wales. Company no: 1106260. Registered office: New Mills, Wotton-under-Edge, Glos, GL12 8JR, UK.

Part no.: H-1000-0421-01-B

Issued: 06.2026