

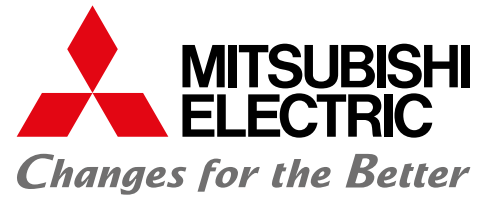

for a greener tomorrow



FACTORY AUTOMATION

MELFA FAMILY

Industrial robots



- Articulated-arm robots
- SCARA robots
- High-performance controllers
- Programming software
- Simulation

Global impact of Mitsubishi Electric



Through Mitsubishi Electric's vision, "Changes for the Better" are possible for a brighter future.

Changes for the Better

We bring together the best minds to create the best technologies. At Mitsubishi Electric, we understand that technology is the driving force of change in our lives. By bringing greater comfort to daily life, maximising the efficiency of businesses and keeping things running across society, we integrate technology and innovation to bring changes for the better.

Mitsubishi Electric is involved in many areas including the following

Energy and electric systems

A wide range of power and electrical products from generators to large-scale displays.

Electronic devices

A wide portfolio of cutting-edge semiconductor devices for systems and products.

Home appliance

Dependable consumer products like air conditioners and home entertainment systems.



Information and communication systems

Commercial and consumer-centric equipment, products and systems.

Industrial automation systems

Maximising productivity and efficiency with cutting-edge automation technology.

Contents

Features in detail	4-5	
Precision and flexibility	6-7	
The technology in detail	8-9	
Software for industrial robots	10	
Your solution partner	11	

Features in detail

Robots from € 1.65/hr

Calculated on the basis of their average service life, around 6–7 years in typical applications, Mitsubishi Electric robots have a surprisingly low total cost of ownership at around € 1.65 per hour for both purchasing and operation.

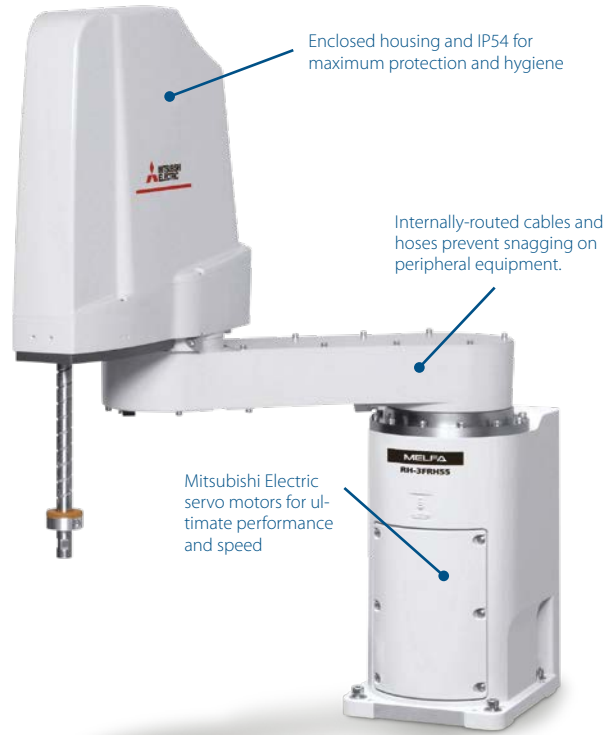

Versatility

Small robots have been used in more than 30,000 applications in widely differing fields since 1978 – and what is more they work around the clock, 24 hours a day, 7 days a week.



Suitable for high-precision component placement with repeatability performance of ± 0.005 mm and a cycle period of just 0.28 s.



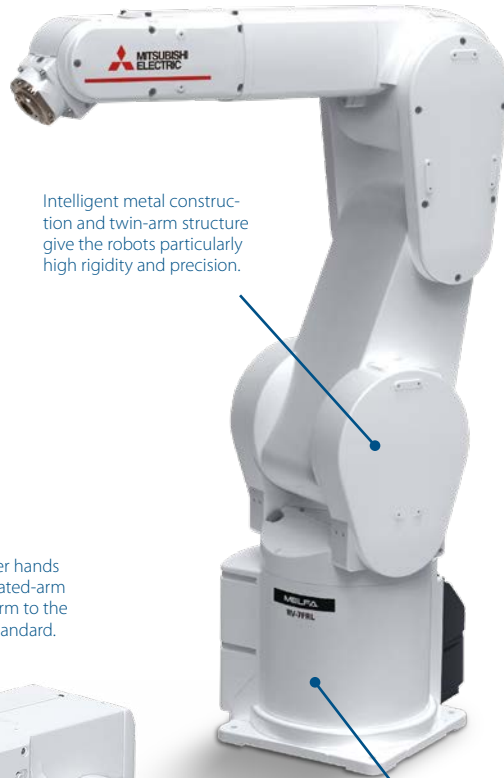

Intelligent metal construction and twin-arm structure give the robots particularly high rigidity and precision.

All the gripper hands of the articulated-arm robots conform to the ISO 9409-1 standard.



The high-precision Harmonic Drive transmission helps to provide exceptional repeatability performance.

A very compact design takes up minimum space for applications in cramped quarters.

Simple programming

A powerful range of robots needs an equally powerful and user-friendly programming interface. Mitsubishi Electric's RT Toolbox3 packages are powerful programming and simulation software tools tailored precisely for the needs of your robots.



Network capabilities

Network connections like Ethernet, ProfiBus, ProfiNet, DeviceNet™ and CC-Link make it easy to integrate Mitsubishi Electric robot controllers in to larger systems, providing users with access to every step of the process.



Precision and flexibility

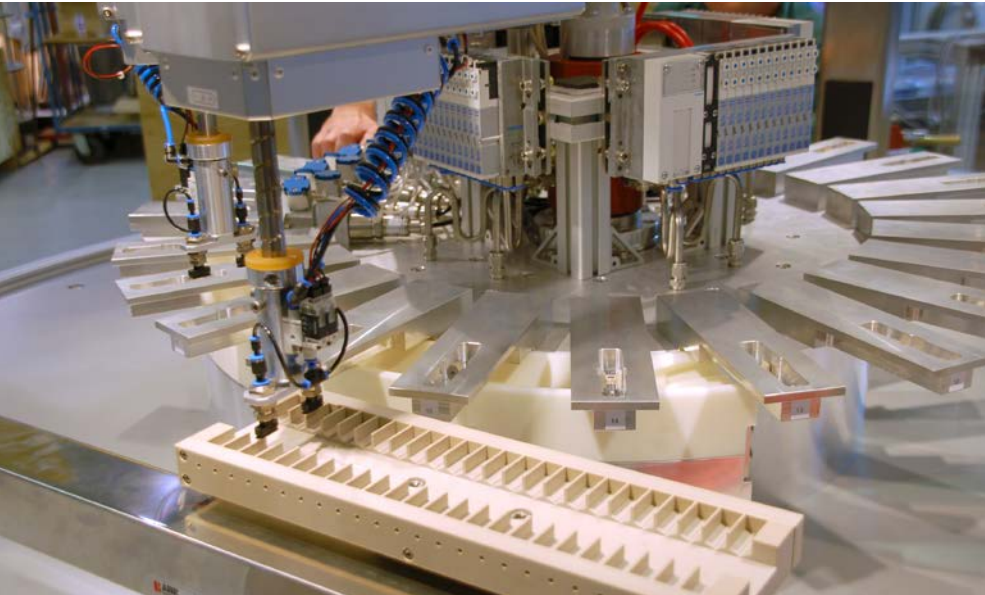

Pharmaceutical industry

Modular control concepts and pharmaceutical industry certification make MELFA robots the ideal partner in the life sciences sector. Integral database connection and an all-embracing control concept facilitate modular and flexible applications in any field where quality and production data have to be backed up in a comprehensible manner.



Food and drink

Increasing hygiene demands, a variety of products and the traceability of production processes are ensured with MELFA robots – now and in the future.

Innovative details and stringent guidelines for MELFA robots guarantee assured quality even in ultra-clean applications.

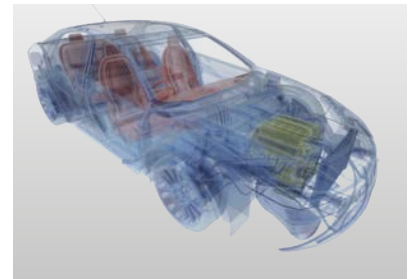

Automotive industry

Highly accurate and extremely flexible MELFA robots are used whenever every little detail matters – haptic measurement, quality assurance and assembly of complex components. MELFA robots carry out their tasks around the clock and at full speed.

Packaging

High-performance and flexibility are a matter of course for MELFA robots. It goes equally without saying that all Mitsubishi Electric automation components can be incorporated. These include additional axes, PLC controllers and operating terminals. Furthermore, cameras can be connected and robots synchronised with conveyor belts. These functions enable packaging tasks to be carried out reliably, quickly and continuously.

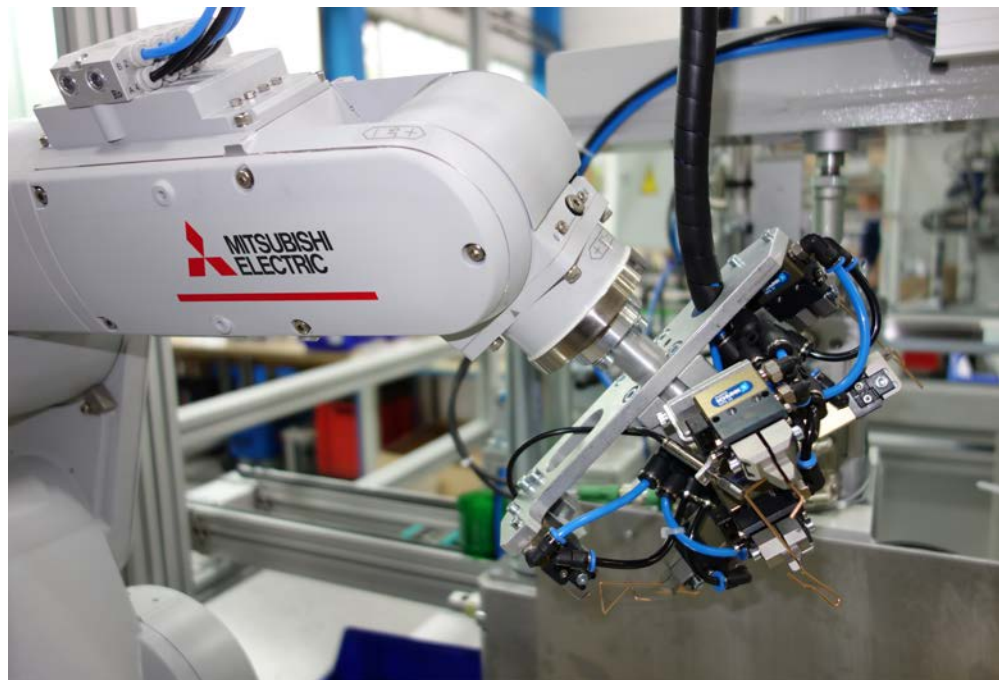

Electronics and mechanical engineering

Mitsubishi Electric provides a wide range of products from parallel-arm robots for the micro assembly of miniature components to fully sealed articulated arm robots. There are no applications which are not suitable for MELFA robots. Whether cleanroom or dirty, oily and dusty environments, the product range always includes the right robot for your application.

Training

Learning from practical experience – a goal which can be achieved in a training environment with the compact, lightweight MELFA robots. Simple programming, simulation options and experienced teachers make entry into the field of robotics easy.

No limits – thanks to standard real-time interfaces and simple programming, MELFA robots provide all sorts of options for using the robots as manipulators, even for complex university research projects.

The technology in detail



Based on these functions, saving of safety equipment and a reduction of safeguarded space is possible which leads to a reduction of cost and space while meeting all safety requirements at the same time.

Sensor-controlled robots with image processing

Mitsubishi Electric's industrial robots can be connected to any object recognition camera system via the Ethernet port or the robot controller's RS232 interface. This enables static and moving parts to be detected with the correct positional information.

The possible uses of sensor-controlled robots in factory automation are manifold. They range from component assembly via quality control and the reworking of workpieces to the location and removal of objects from a conveyor belt.



More safety

The DIN ISO-10218 safety standard is common to all robots and therefore guarantees safe operation in all applications. Mitsubishi Electric's supplementary product range including safety controllers enables the robots to be integrated into a common safety concept. Ready-made example projects make it possible for anyone to put together even complex systems quickly and effectively.

The optional "MELFA SafePlus" safety technology for the F series robot controllers has functions available like reduced safe speed control, safe limited control range and safe torque monitoring, which can be activated via safety inputs. Logic for each safe I/O can be edited and in combination with the position monitoring function a safe system can be constructed without using a Safety PLC.

F-Q series – full PLC functionality in the robot

As robots are never installed on a stand-alone basis, the system must be easy to integrate into its working environment to enable it to communicate with PLC and motion systems as well as operating panels and other systems. Together with the modular robot CPU, the Mitsubishi Electric iQ Platform provides the ideal basis for integrating the full functionality of a PLC into the robot controller – once again demonstrating the company's role as a pioneer in automation technology.

Simple integration into complex applications

Up to eight additional axes can be connected directly to the robot controller with just one cable. Of these, two axes can be used as additional interpolating axes, e.g. as the seventh and eighth robot axis.

The special feature compared with other systems is that all additionally connected axes can be programmed in exactly the same way as the robot, using the same Teach-Box or the standard RT ToolBox3 software. This avoids the additional expense of software, training and programming.

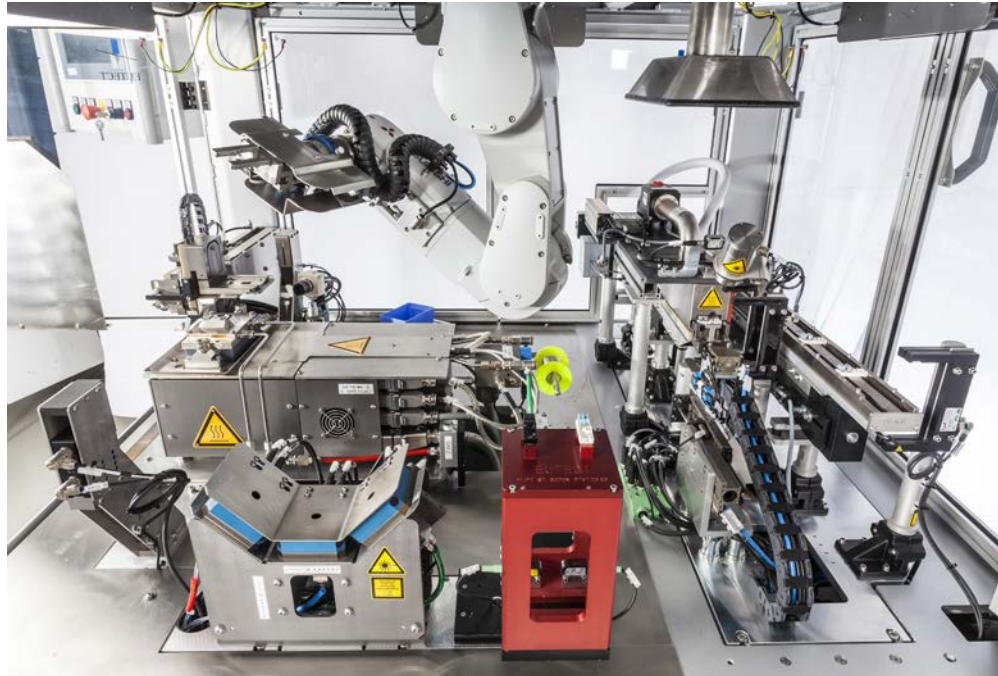

More efficient monitoring and maintenance functions

Direct connection of the company's infrastructure GOT operating terminal via Ethernet opens up a number of monitoring, control and maintenance functions for the robot. The correction of taught points, the backup and restore function, the entry of production data, and the selection and control of processes are just some of the options provided by the Mitsubishi Electric operating terminal in conjunction with MELFA robots.

Open communication for PC connection

The robot controller can be connected to an MES system, for example for easily and quickly changing manufacturing sequences without stopping production.

Furthermore, the robot can be initiated for any kind of movement in real time. Flexible and complex movements, which are generated graphically on the PC, for example, can be realised in this way.

Programming and simulation

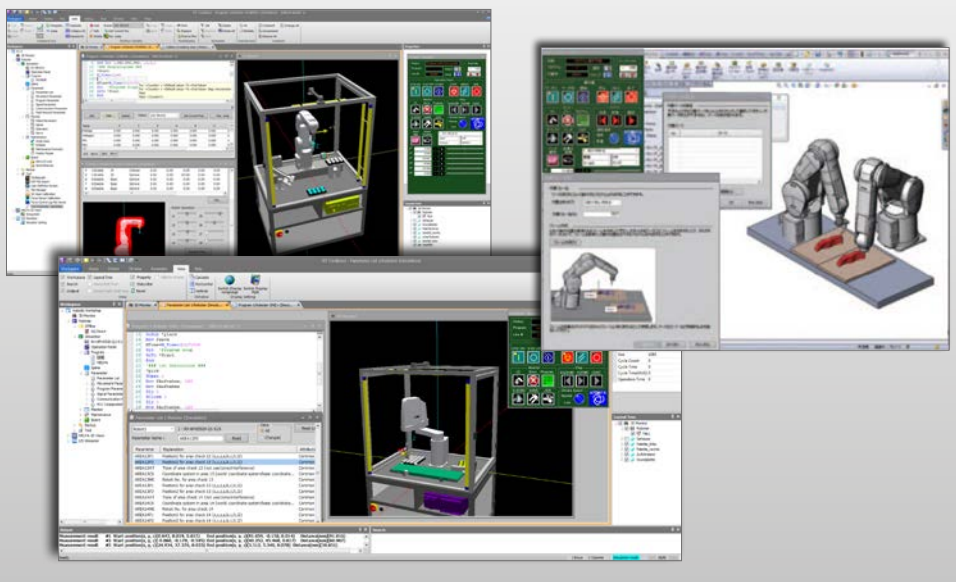

Simulation of a Mitsubishi Electric industrial robot directly in an application

High-performance industrial robots also require high-performance software. For this reason, more and more automation engineers are opting for the versatile and convenient Mitsubishi Electric software. All tasks, such as the creation of projects, programming and simulation, are implemented intuitively and mesh perfectly with one another. This results in optimum movement sequences in the shortest possible installation and commissioning time.

Programming

Offline and online programming with simulation

Simulation

3D-CAD import and up to 16 robots can be simulated in one project; additional axes can be connected and positions taught directly in the simulation.

Parameters

Parameter structure for the simple parameterisation of functions; complete overview of all parameters with display of modified values only.

Maintenance

Full backup and restore function and monitoring of service intervals, production runtimes and product cycles.

Monitoring

Display of load currents, position values, variables and variable positions. Monitoring of switching signals, program execution and fault history.

Documentation

Full project documentation with output of modified parameters, program code and positions.

3D-simulation with RT Toolbox3 Pro

The RT Toolbox3 Pro add-in tool for SolidWorks enables a robot in a production system to be simulated on a PC, and converts the workpiece paths into robot position data.

Supplementing the SolidWorks platform by the addition of RT Toolbox3 Pro extends the simulation functions and opens up new simulation possibilities.

- The CAD data of the system can be directly imported
- Grippers can be connected directly to the robot
- Handling of workpieces
- Offline teaching in a 3D environment
- Creation of robot programs
- Collision-checking between robot and system environment

The convenient operating terminal for mobile teaching

The R56TB is a powerful operating panel for carrying out all tasks directly at the robot, from controlling the robot and displaying the loads by means of the input/output display to complete program creation and parameterisation. The comprehensive functions ensure optimum utilisation of the robot system and thus reduce setup times.

The integral USB port enables data to be exchanged conveniently, and complete controller backups can be uploaded and downloaded through a memory stick.





Technical Information Section

Further publications within the industrial automation range

Brochures

HMI family

Product catalogue for operator terminals, supervision software and accessories

MR family

Product catalogue for servo amplifiers and servo motors as well as motion controller and accessories

FX family

Product catalogue for programmable logic controllers and accessories for the MELSEC FX family

Q/L family

Product catalogues for programmable logic controllers and accessories for the further MELSEC PLC series

FR family

Product catalogue for frequency inverters and accessories

LVS family

Product catalogue for low voltage switchgears, magnetic contactors and circuit breakers

Automation Book

Overview on all Mitsubishi Electric automation products, like frequency inverters, servo/motion, robots etc.

Further service supplies

This product catalogue is designed to give an overview of the extensive range of Mitsubishi Electric MELFA RV-FR, RH-FRH and RP-ADH series. If you cannot find the information you require in this catalogue, there are a number of ways you can get further details on configuration and technical issues, pricing and availability.

For technical issues visit the <https://eu3a.mitsubishielectric.com> website.

Our website provides a simple and fast way of accessing further technical data and up to the minute details on our products and services. Manuals and catalogues are available in several different languages and can be downloaded for free.

For technical, configuration, pricing and availability issues contact our distributors and partners.

Mitsubishi Electric partners and distributors are pleased to answer your technical questions or help with configuration building. For a list of Mitsubishi Electric partners please see the back of this catalogue or alternatively take a look at the "contact us" section of our website.

About this product catalogue

This catalogue is a guide to the range of products available. For detailed configuration rules, system building, installation and configuration the associated product manuals must be read. You must satisfy yourself that any system you design with the products in this catalogue is fit for purpose, meets your requires and conforms to the product configuration rules as defined in the product manuals. Specifications are subject to change without notice. All trademarks acknowledged.

© Mitsubishi Electric Europe B.V., Factory Automation - European Business Group

The products of Mitsubishi Electric Europe B.V., that are listed and described in this document, are neither subject to approval for export nor subject to the Dual-Use List.

1 Robots

- ♦ Overview robots 4
- ♦ Special functions 7
- ♦ Industrial robots RV-2FR(L)(B) 15
- ♦ Industrial robots RV-4FRLM 17
- ♦ Industrial robots RV-7FRM/7FRLM/7FRLLM 19
- ♦ Industrial robots RV-13FRM/RV-13FRLM/RV-20FRM 21
- ♦ Industrial robots RV-35F/50F/70F 23
- ♦ Industrial robots RP-1ADH/RP-3ADH/RP-5ADH 25
- ♦ Industrial robots RH-1FRHR 27
- ♦ Industrial robots RH-3FRHR 29
- ♦ Industrial robots RH-FRH 31
- ♦ Industrial robots RD-1F500/RD-1F800/RD-1F1100/RD-1F1300 34
- ♦ System overview 31

2 Controller

- ♦ Controller 36
- ♦ Dimensions of the control units 37

3 Accessories

- ♦ Teaching box 38
- ♦ Force sensor, MELFA SafePlus, MELFA Smart Plus Card 39
- ♦ Wiring set 40
- ♦ Pneumatic valve sets, bellows 41
- ♦ Interface boards 42
- ♦ Adaptor cables, connectors 43
- ♦ Tubes, extension cables 44
- ♦ PC and I/O connection cables, controller protection box, buffer batteries 45
- ♦ General overview of options 46

4 Programming language

- ♦ MELFA-BASIC 48

5 Software

- ♦ RT Toolbox3 49
- ♦ RT Toolbox3 Pro 50

- Index 51

Overview robots

A complete lineup

Large range of robot models makes selection easy

Mitsubishi Electric produces a comprehensive range of robot models to cater to the full spectrum of modern needs. All Mitsubishi Electric robots are powerful, fast and compact – that goes almost without saying.

The product range includes the almost universal articulated-arm robots with 6 degrees of freedom and payloads of 2 kg to 70 kg and SCARA robots with 4 degrees of freedom and payloads of 3 kg to 20 kg for assembly and palletising tasks.

Three special models are the unique high-precision robots with their parallel arm structure for very fast micro handling tasks with payloads of 1 kg to 5 kg as well as the flexible high-speed SCARA robots for ceiling mounting.



Vertical, multiple-joint type (RV)



Type	RV-2FR(B)	RV-2FRL(B)	RV-4FRLM	RV-7FRM	RV-7FRLM	RV-7FRLLM
Number of axis	6					
Payload kg	2		4	7	7	7
Maximum reach radius mm	504	649	649	713	908	1503
Environmental specifications	Standard	IP30		IP67	IP67	IP67
	Clean	—		(ISO class 3 optional)	(ISO class 3 optional)	(ISO class 3 optional)
						
Controller	CR800-D/CR800-R + R16RTCPU					

Horizontal, multiple-joint type (RH/RP)



Type	RP-1ADH	RP-3ADH	RP-5ADH	RH-1FRHR	RH-3FRHR	
Number of axis	4					
Payload kg	1	3	5	1	3	
Maximum reach radius mm	150x105 (corresponds to DIN A6)	210x148 (corresponds to DIN A5)	297x210 (corresponds to DIN A4)	550	350	
Environmental specifications	Standard	IP30	IP30	IP20 (IP65 optional)	IP20 (IP65 optional)	
	Clean	—	—	—	(ISO class 5 optional)	
 						
Controller	CR1DA			CR800-D/CR800-R + R16RTCPU		

Advanced intelligence, safety and integration

The concept of FR robots offers a simple approach to advanced and flexible production to handle all automation needs. This concept is based on 3 key features

- Intelligence: "MELFA Smart Plus" offers greater accuracy and shorter startup times, making installation simpler and more advanced tasks possible.

- Safety: A comprehensive range of safety functions, including position and speed monitoring, allow work to be conducted in cooperation with people

- Integration: MELSEC iQ-R compatible robot controller and the e-F@ctory integrated FA solution offers seamless integration of robots and IT systems.



RV-13FRM	RV-13FRLM	RV-20FRM	RV-35FM ^①	RV-50FM ^①	RV-70FM ^①
6	6	6	6	6	6
13	13	20	35	50	70
1094	1388	1094	2050	2050	2050
IP67	IP67	IP67	IP40/IP67	IP40/IP67	IP40/IP67
(ISO class 3 optional)	(ISO class 3 optional)	(ISO class 3 optional)	—	—	—



CR800-D/CR800-R + R16RTCPU	CR760^①
-----------------------------------	--------------------------



RH-3FRH5515	RH-6FRH5520	RH-12FRH8535	RH-20FRH10035	RD-1F500 ^①	RD-1F800 ^①	RD-1F1100 ^①	RD-1F1300 ^①
4	4	4	4	4	4	4	4
3	6	12	20	2	3	3	3
550	550	850	1000	500	800	1100	1300
IP20	IP54 (IP65 optional)	IP54 (IP65 optional)	IP54 (IP65 optional)	IP65	IP65	IP65	IP65
(ISO class 3 optional)	(ISO class 3 optional)	(ISO class 3 optional)	(ISO class 3 optional)	(IP69K optional)	(IP69K optional)	(IP69K optional)	(IP69K optional)



CR800-D/CR800-R + R16RTCPU	CR750^①
-----------------------------------	--------------------------

① Please contact your Mitsubishi Electric representative for more details.

Model designation



RV-7FRLM-D



RH-1FRHR5515-D



RH-6FRH5520N-R

Vertical, multiple-joint type (RV)

RV-□FR□M-□-S□□□

- : special type, SH□□: internal wiring
- Controller type: D: CR800-D, R:CR800-R
- Env. spec.: Blank: standard, C: clean room spec., M: oil mist (IP67)
- Arm length: Blank: standard arm, L: long arm, LL: super long arm
- FR: FR series
- Max. payload: (2: 2 kg, 4: 4 kg, 7: 7 kg, 13: 13 kg, 20: 20 kg)
- RV: vertical, multiple joint type

Horizontal, multiple-joint type (RH)

RH-□FRH□□N-□-S□□□

- : special type
- Controller type: D: CR800-D, R:CR800-R
- Env. spec.: Blank: standard, C: clean room spec., M: oil mist (IP67), N: IP54 and H1 grease
- Stroke length: 12: 120 mm, 15: 150 mm, 20: 200 mm, 34: 340 mm, 35: 350 mm, 45: 450 mm
- Arm length: 35: 350 mm, 45: 450 mm, 55: 550 mm, 70: 700 mm, 85: 850 mm, 100: 1000 mm
- FRH: FR series, FRHR: FR series ceiling type
- Max. payload (1: 1 kg, 3: 3 kg, 6: 6 kg, 12: 12 kg, 20: 20 kg)
- RH: horizontal, multiple joint type

Shortened takt times

Improved control performance

Produced the fastest operating performance in its class using high-performance motors and unique driver control technology developed by Mitsubishi Electric.

- Enabled high torque output at high rotational speed, shortening acceleration/deceleration time
- Shortened positioning time for improved device throughput
- Continuous operability improved

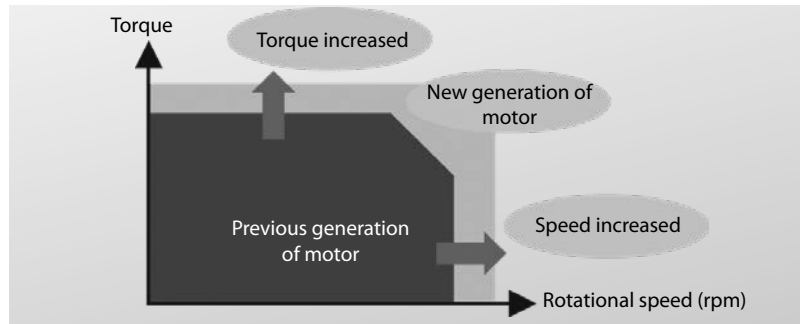

Improved tooling performance

Internal routing of hand wiring and signal cable

- Internal routing of cables and air hoses
- No interference with cables around devices
- Reduced risk of wiring disconnection
- Optional models of RV with internal wiring and hoses up to the hand are available (-SH□□)



Flexibility with internal Ethernet cable tools

Internal installation of wiring and piping for connecting to vision sensors enabled.

- Hand: 8 input points/8 output points
- Ethernet cable for the vision sensor
- Additional cables to control vision systems or other sensors

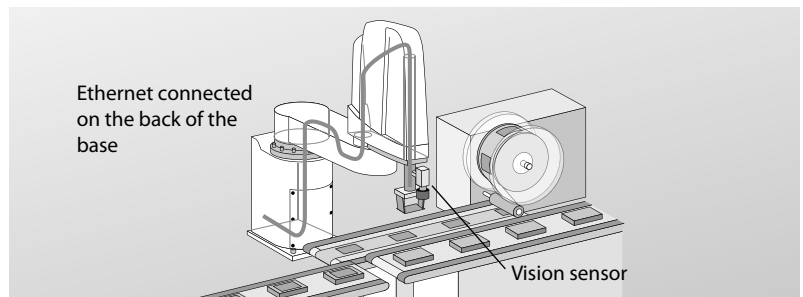

Full use of installation space

Expanded pivotal operating range

- Improved flexibility for robot layout design
- More effective use of access space around the entire perimeter
- Shortened movement distances, enabling takt times to be shortened

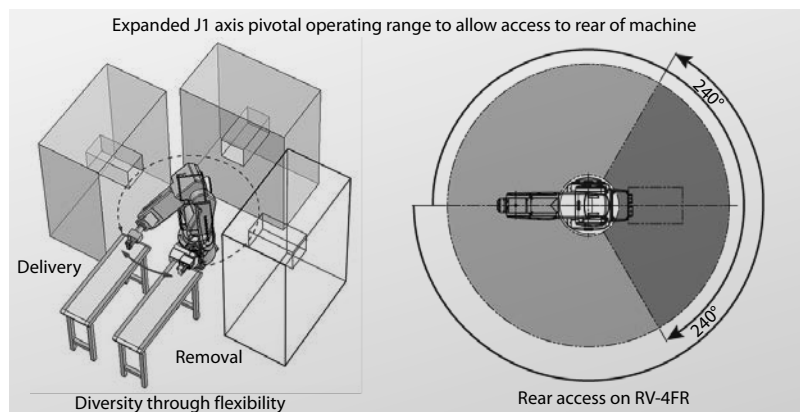

Special functions

■ Improved user friendliness

Simple automatic operation from the teaching box

- Same functions as on the operating panel of the robot controller
- Monitoring screens can be set up individually to match the needs of user debugging conditions
- Enabled for R32TB and R56TB
- User definition screens for customized operation screens and monitoring

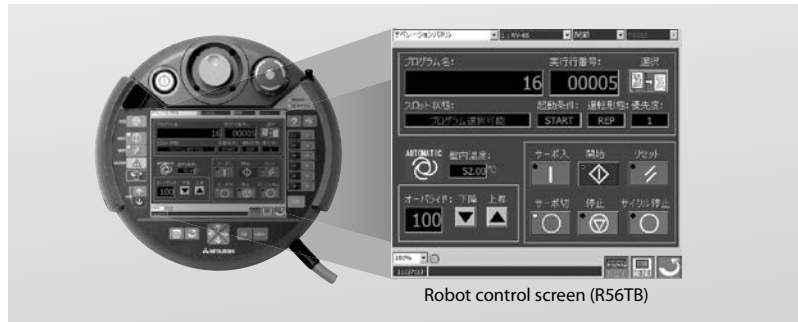

Enables automatic operation of servo motor on/off, startup and shutdown, reset, program selection, and other operations.

GOT backup/restore functions (Supported on GT14, GT15, GT16, GT21, GT23, GT25 and GT27)

Robot data on the GOT can be backed up to and restored from a CF-/SD-card or USB memory stick. Due to the direct Ethernet connection a PC is not required

- This helps prevent data from being lost due to the empty battery/battery or robot malfunction.
- Data can be saved after periodic maintenance tasks are performed or when unexpected errors occur. Dramatically improves serviceability



Maintenance (log function)

Information before and after errors occur (state changes, I/O, external system variables, etc.) and program run states can automatically be transferred to an FTP server as log data or saved on an SD card. Operation logs can also be downloaded, enabling efficient analysis of error causes.

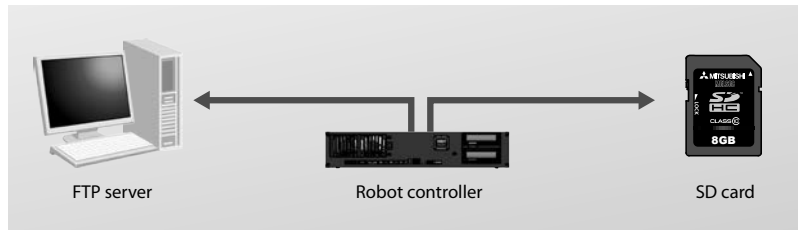

Easier robot information management

Memory is included in the robot body and used to store robot-specific information. This makes it easy to switch robot controllers.

Information can also be collected without visiting the workplace, simplifying the formulation of maintenance plans.

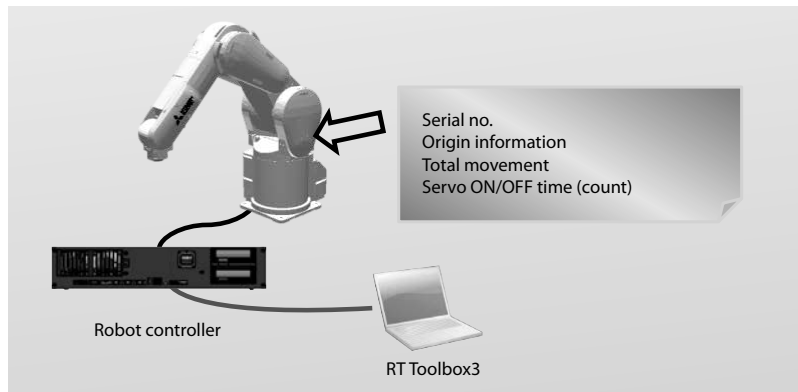

Improved accuracy

Active gain control

- Optimal motor control tuning settings in real-time based on robot operating position, posture and load conditions
- Improved palletization accuracy
- Improved trajectory accuracy

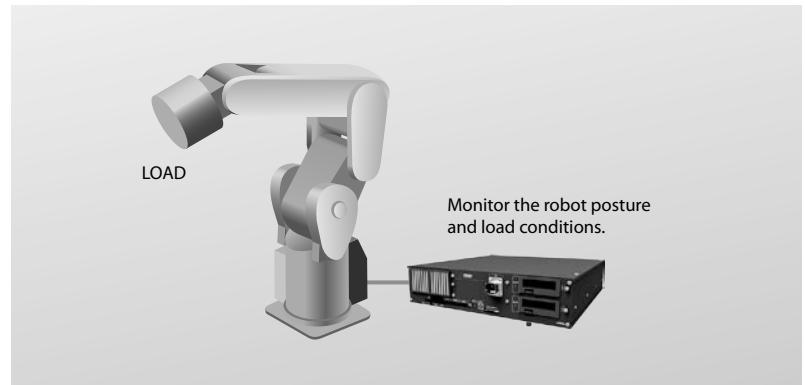

Simplified tool length setting

Tool settings for the tool coordinate system can be set by attaching the tool and using three to eight of the same teaching points.

- Eliminates errors introduced when the tool was made.
- Higher precision
- Saving time, since measuring the tool is not necessary.

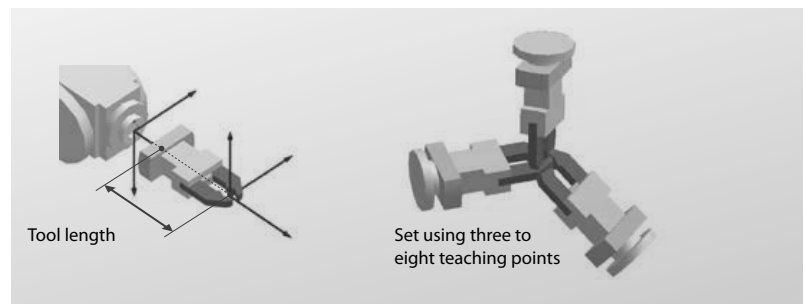

Adaptation to operation

Compliance control

This function reduces the rigidity of the robot arm and tracks external forces.

- Special hands and sensors are unnecessary
- Reduced tooling costs
- Shortened line stop times

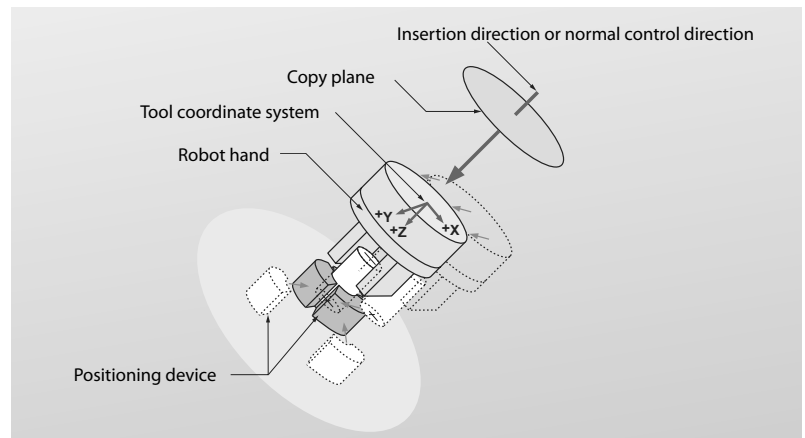

Special functions

■ Connection to peripheral devices

Network vision sensor

The robot and camera can be easily simultaneously calibrated through a simple process using vision sensor setting tools.

- Simple connection between the robot and camera using Ethernet
- Simple control using vision control commands in the robot programs
- Shortened takt times
- Reduced system costs

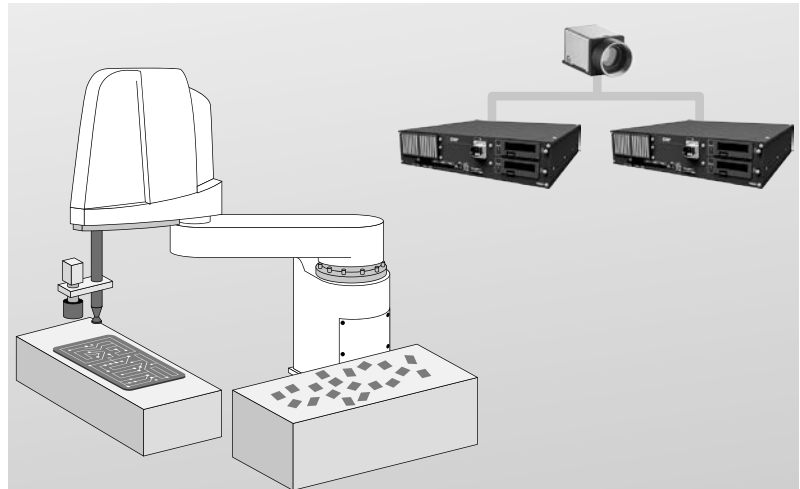

Tracking

Transport, alignment, and installation work, etc. can be performed while robots are tracked with the workpiece on the conveyor without stopping the conveyor.

- Higher throughput of components
- Easy programm creation (MELFA BASIC V/VI)
- No need for an additional positioning device
- Prediction of workpiece position for better tact times
- Circular tracking available

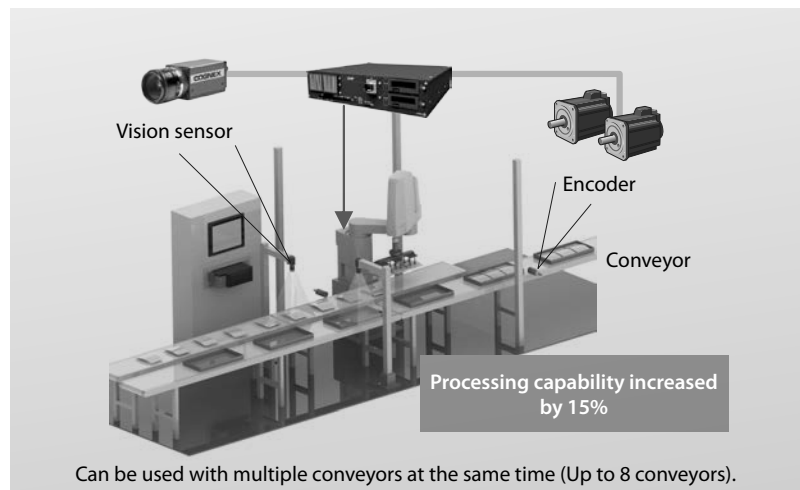

Additional axis function

The layout can be set up to include the robot traveling axis and turntable as well as user machines separate from the robot such as loaders and positioning devices.

- Up to 8 additional axes can be controlled by the controller
- No additional motion control hardware necessary
- Plug-and-play compatibility with the MELSERVO MR-J4-B servos
- Two axes can be controlled simultaneously with the robot
- No need of special programming knowledge, because robot software is used.

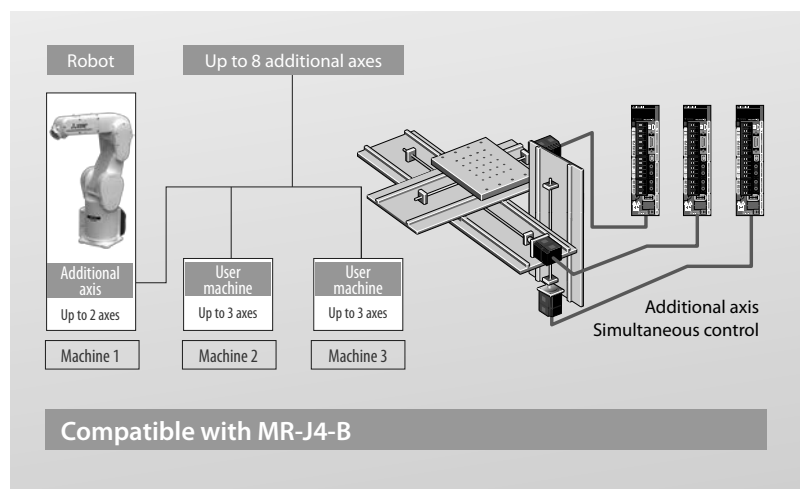

■ CC-Link IE Field Network Basic function

FR series robot controller supports the slave stations of “CC-Link IE Field Network Basic” as a built-in function

- CC-Link IE Field Network Basic compatible products and Ethernet compatible products can be connected on the same Ethernet communications line
- MELSEC iQ-R/iQ-F/Q/L series PLC CPU and the MELFA FR series robot controller have built-in Ethernet as standard, so no dedicated option is required
- enabling a highly-flexible and cost-effective system

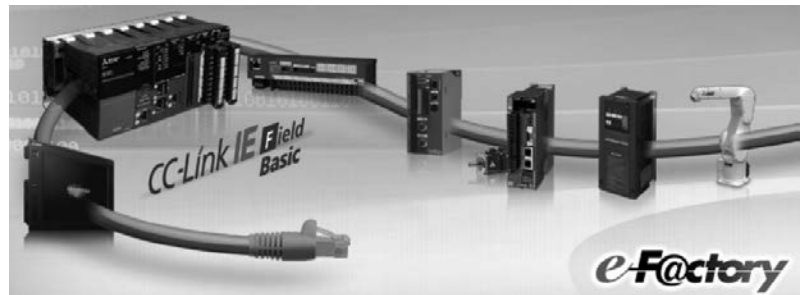

■ Collision avoidance (R type controllers only)

The robot is stopped, even before collisions can occur. This is possible due to the fast position control, that is implemented in the iQ Platform as a standard feature.

- Robots can operate together in a confined space without interfering with each other
- Reduces the number of recovery man-hours required after a collision
- Already represented in the simulation of the RT Toolbox3
- Can be used in Teach-Mode already

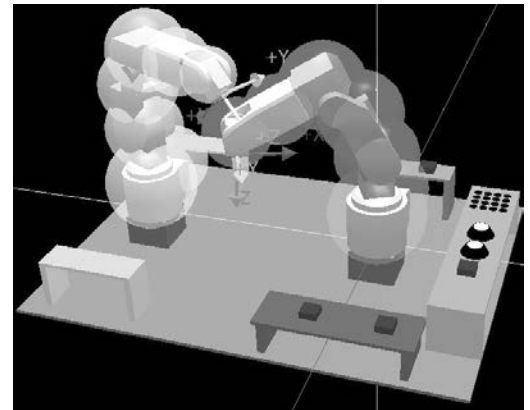

Possible collisions with other robots are avoided.

■ Coordinated control (R type controllers only)

Enables coordinated control between multiple robots through CPU connection between the robots.

- Easy to operate by predefined default function
- Enables transport of lengthy or heavy objects using small-sized robots
- Programming as already known by using standard commands



Enables installation work to be completed while gripper positions between robots are maintained.

Special functions

Intelligent technology

Force sensor

- Monitors the force applied to the robot gripper to handle processes like a human operator
- Keeps the force constant so that the workpiece can be handled without causing damage
- Complex assembly tasks achieved through techniques such as phase matching
- Force log function for checking the quality check

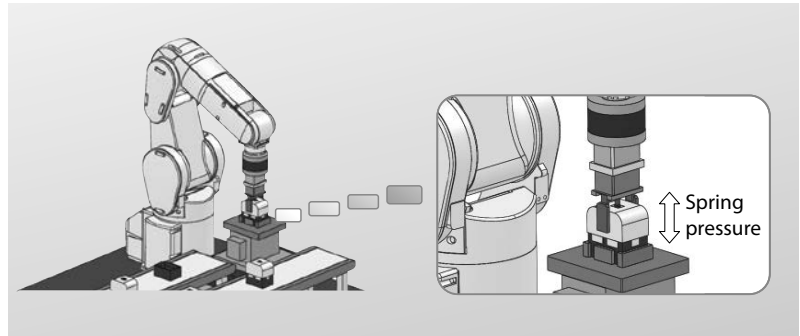

Arm temperature compensation

- Monitors temperature of motor encoders
- Improves positioning accuracy by compensating for thermal expansion in the robot arm

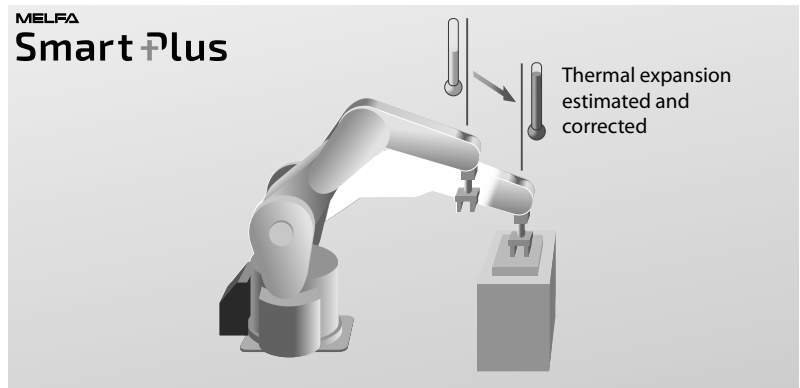

Calibration assistance

- Reduces the time for calibration during start up and improves position accuracy
- Automatically correcting the robot and camera coordinates
- Automatically correcting the robot and workpiece coordinates
- Adjust the robot location relative to other robots

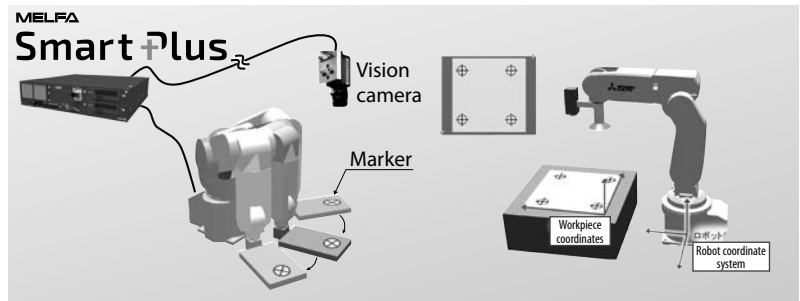

Coordinate control for additional axes

- Allows synchronized operation when a robot is installed on an additional axis (linear axis) to handle large workpieces which exceed robot's working range
- Allows synchronized operation when tracking of the robot with a workpieces on an additional axis (linear axis) is executed

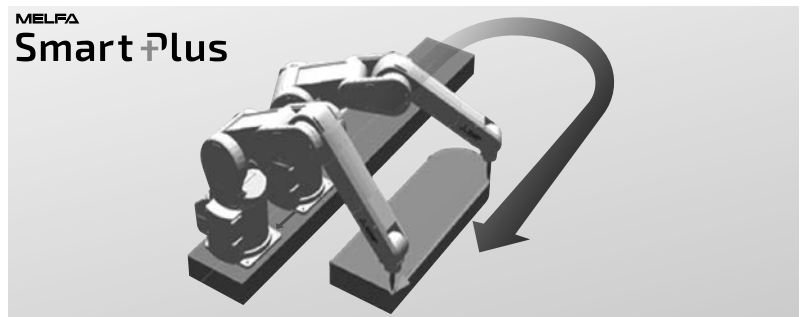

MELFA SafePlus features

“MELFA SafePlus” safety technology for the FR series robot controllers

- Supported Safety functions:
 - STO (Safe Torque Off), SS1 (Safe Stop 1), SS2 (Safe Stop 2), SOS (Safe Operation Stop), SLS (Safely-Limited Speed), SLP (Safely-Limited Position)
- All functions follow the safety standards EN ISO 10218-1 (Industrial robots), EN ISO 13849-1 (Safety of machinery), EN 62061/IEC 61508 (Functional safety) and EN 61800-5-2 (Safety function drive).



Reduced speed control (safe limited speed, SLS)

Function to control the robot speed with safe limited speed to secure operator's safety when signaled via safety input signals. Up to four different zones with different limited speed can be activated. Operator can be interactive while the robot is running in automatic mode, but with safe low speed.

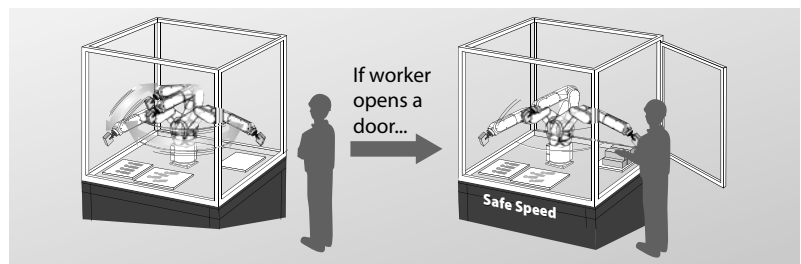

Limited range control (safe limited position, SLP)

Function to control the robot movement range and to ensure that the robot does not exceed the set limit activated by the safety input signal. This function monitors the robot arm. If the robot or the attached hand exceeds any set plane, the robot will stop immediately.

Independent areas can be defined for different safety situations.

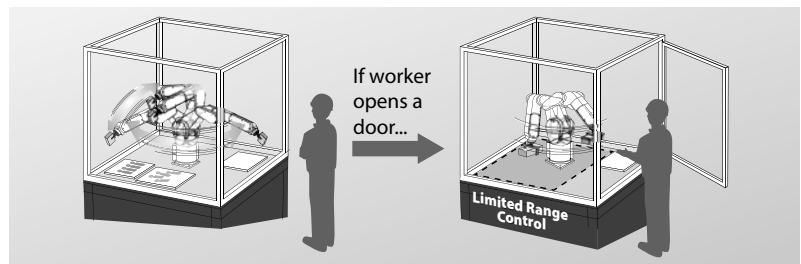

Safety logic editing

Expands the dual safety channels to 8 inputs and 4 outputs. Logic for each safe I/O can be edited and in combination with the position monitoring function a safe system can be constructed without using a Safety PLC.

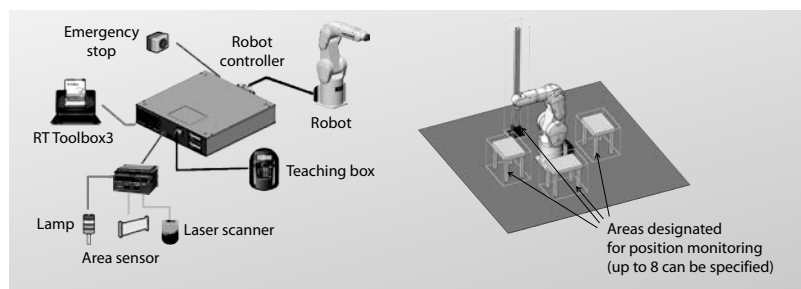

Collision detection function (Standard feature)

This function detects if the arm collides with an obstacle while teaching or operation, and helps to reduce damaging the robot arm and tools. The detection level can be changed according to the protection targets.

The operation which should follow after the collision detection can be programmed to suit to the application, for example stop immediately and show error or retract and show then the error.

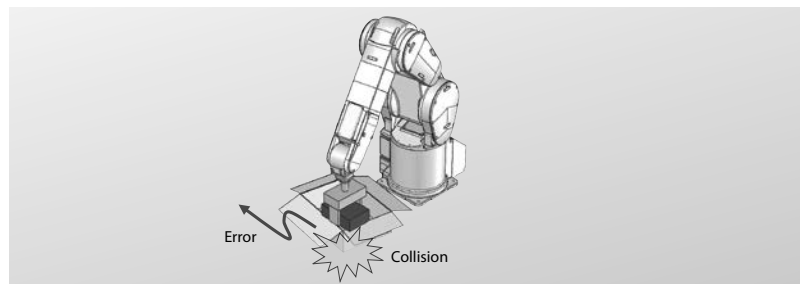

Special functions with GOT terminals and the iQ Platform

Shared memory expansion

Enhanced efficiency of monitoring and maintenance operations onsite using a single GOT (display device) as the Human Machine Interface (HMI).

- Enables the robot to be controlled from the GOT even without a teaching box
- Current robot position data, error information, and other items can be displayed easily on the GOT
- Connection with a single Ethernet cable and direct access to the control unit
- 8192 input an output points can be exchanged via Ethernet connection

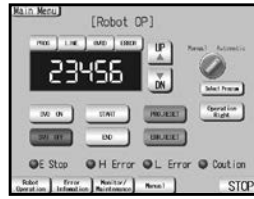

Operation panel screen

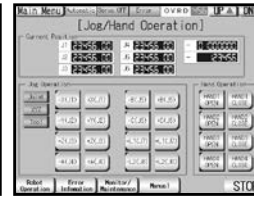

Jog/hand operation screen



Current position monitor screen

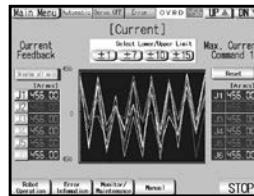

Current value and load factor monitor screen



Maintenance forecast screen

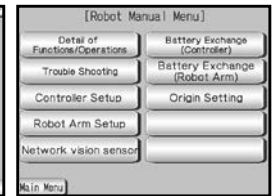

Manual/video display menu

Direct execution function for programmable controllers

Robots can be controlled easily using programmable controller language.

- Control of system operation using an single programmable controller
- Direct changing of system specifications via programmable controller
- Direct handling of troubleshooting
- Simple movement to taught positions by PLC program
- No need to use any robot programs

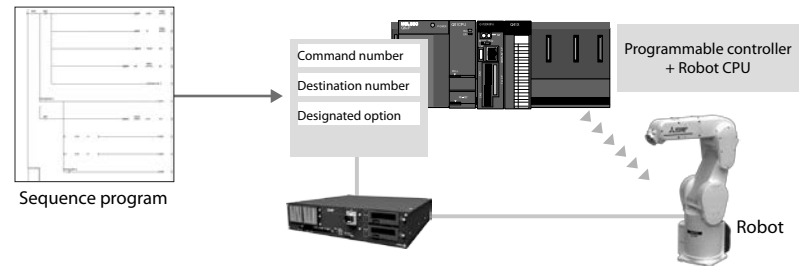

Details	
Operation	Joint-interpolated motion Linear-interpolated motion
Motion control	Designated override Designated acceleration/deceleration settings Designated speed Tool settings Designated auxiliary motion Opening/closing of hand

Industrial robots RV-2FR(B)/RV-2FRL(B)



RV-2FR(B)

The articulated arm robots RV-2FR(B)/RV-2FRL(B)

The compact and light RV-2FR(B)/RV-2FRL(B) can be seamlessly integrated into different automation systems. Flexibility and the wide range of motion permits acting in applications with limited space, like mounting, assembling, palletising, sorting or bonding. Even the basic model is available with a fully equipped standard controller or as PLC robot with integration onto the iQ Platform.

Highlights:

- 2 different arm length with 504 mm and 649 mm
- Only 19/21 kg weight and extremely compact
- Highest flexibility
- Floor, wall and ceiling installation possible
- Position repeatability of ± 0.02 mm

Characteristics/Functions	Specifications			
	RV-2FR-D/ RV-2FR-R	RV-2FRB-D-S25/ RV-2FRB-R-S25	RV-2FRL-D-S25/ RV-2FRL-R-S25	RV-2FRLB-D-S25/ RV-2FRLB-R-S25
Degrees of freedom (no. of axes)	6			
Installation posture	Floor, ceiling or wall mounting possible			
Structure	Vertical multiple-joint type			
Drive system	AC servo axes J1, J4, J6: no brake	AC servo (brakes on all axes)	AC servo axes J1, J4, J6: no brake	AC servo (brakes on all axes)
Position detection method	Absolute encoder			
Payload capacity	rated	2		
	maximum	3		
Arm reachable radius (to the center point of the J5 axis)	mm	504	649	
Operating range	waist (J1)	480 (-240–240)	480 (-240–240)	
	shoulder (J2)	240 (-120–120)	237 (-117–120)	
	elbow (J3)	160 (0–160)	160 (0–160)	
	wrist twist (J4)	400 (-200–200)	400 (-200–200)	
	wrist pitch (J5)	240 (-120–120)	240 (-120–120)	
	wrist roll (J6)	720 (-360–360)	720 (-360–360)	
Maximum speed	waist (J1)	300	225	
	shoulder (J2)	150	105	
	elbow (J3)	300	165	
	wrist twist (J4)	450	412	
	wrist pitch (J5)	450	450	
	wrist roll (J6)	720	720	
Maximum composite speed	mm/s	4955	4200	
Cycle time (25x300x25 mm with 1 kg load)	sec	0.6	0.7	
Position repeatability	mm	± 0.02		
Ambient temperature	$^{\circ}\text{C}$	0 to 40		
Weight	kg	19	21	
Tolerable moment	wrist twist (J4)	4.17		
	wrist pitch (J5)	4.17		
	wrist roll (J6)	2.45		
Tolerable inertia	wrist twist (J4)	0.18 (0.27)		
	wrist pitch (J5)	0.18 (0.27)		
	wrist roll (J6)	0.04 (0.1)		
Tool wiring		Hand input 4 points/hand output 4 points		
Tool pneumatic pipes		\varnothing 4x4 (from the base level to the gripper hand area)		
Supply pneumatic pressure	MPa	0.5 \pm 10 %		
Gripper flange		ISO 9409-1-31.5		
Protection rating		IP30		
Robot controller		CR800-D/CR800-R + R16RTCPU		
Order information	Art. no.	313052/ 314029	313053/ 314030	313054/ 314031
				313085/ 314032

Dimensions and movement ranges

Robot arms RV-2FR(L)(B)

RV-2FR(B)

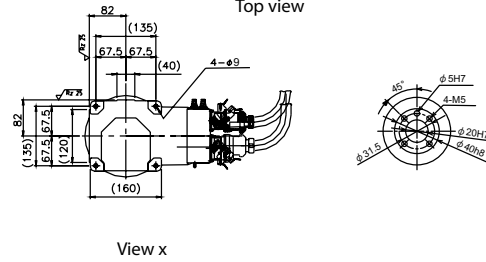
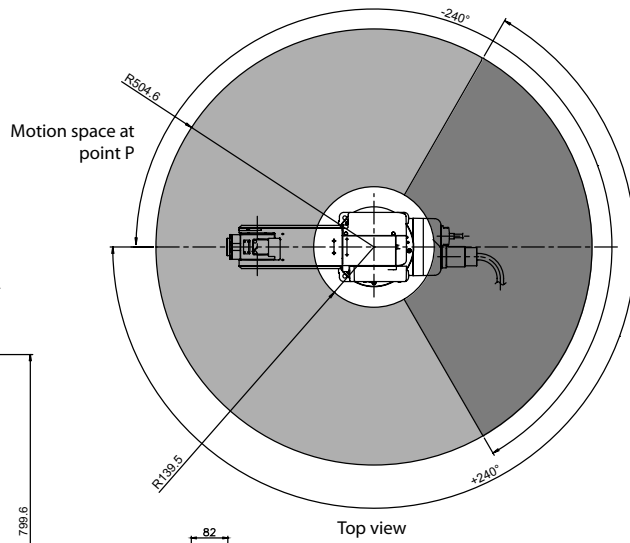
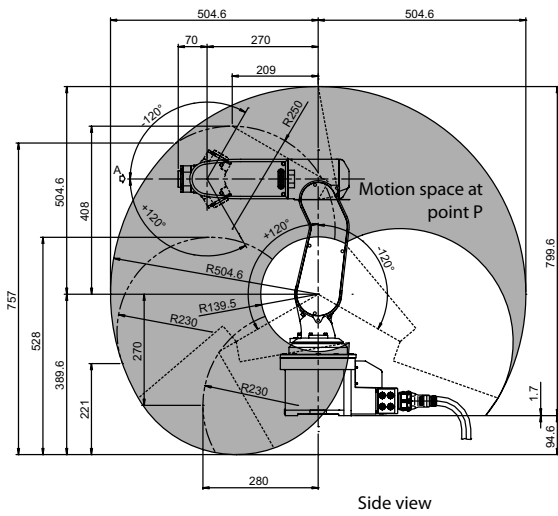

Dimensions: mm

RV-2FRL(B)

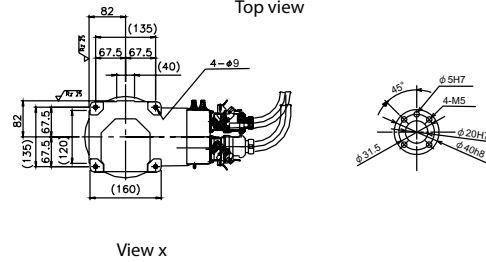
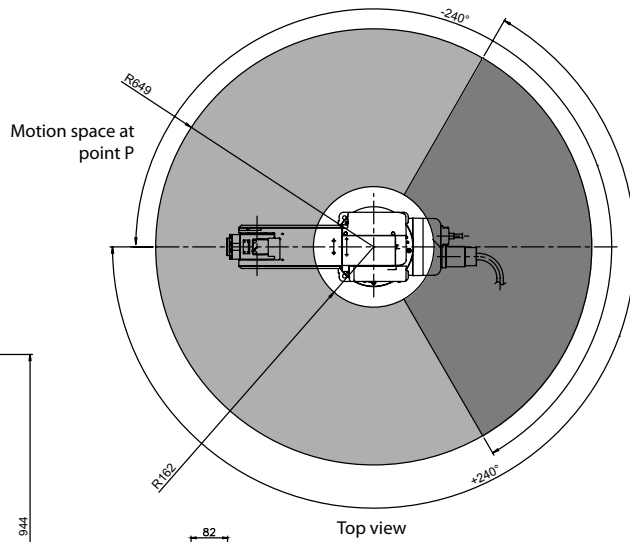
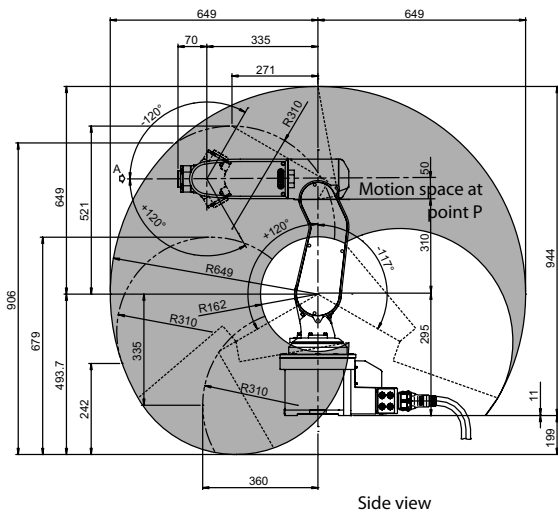

Dimensions: mm

Industrial robots RV-4FRLM



RV-4FRLM

The articulated arm robots RV-4FRLM

The robots of the RV-4 FR series are designed for easy integration into existing work cells or innovative and compact applications. Features such as the direct control over local I/Os allows the robot to interact directly with sensors and actuators, speeding up and simplifying system building. A new innovative design allows a maximum of flexibility, so that the robot can expand his workspace to work faster and more flexible.

Highlights:

- Slim arm design
- IP67 protection
- Internal routed cables and air hoses
- Extended maintenance intervals
- 4 kg rated and maximal payload

Characteristics/Functions	Specifications	
	RV-4FRLM-D	RV-4FRLM-R
Degrees of freedom (no. of axes)	6	
Installation posture	Floor, ceiling or wall mounting possible (wall mounting with limitations in the J1 axis)	
Structure	Vertical multiple-joint type	
Drive system	AC servo (brakes on all axes)	
Position detection method	Absolute encoder	
Payload capacity	maximum	kg
Arm reachable radius (to the center point of the J5 axis)		mm
Operating range	waist (J1)	degree
	shoulder (J2)	degree
	elbow (J3)	degree
	wrist twist (J4)	degree
	wrist pitch (J5)	degree
	wrist roll (J6)	degree
Maximum speed	waist (J1)	degree/s
	shoulder (J2)	degree/s
	elbow (J3)	degree/s
	wrist twist (J4)	degree/s
	wrist pitch (J5)	degree/s
	wrist roll (J6)	degree/s
Maximum composite speed		mm/s
Cycle time (25x300x25 mm with 1 kg load)		sec
Position repeatability		mm
Ambient temperature		°C
Weight		kg
Tolerable moment	wrist twist (J4)	Nm
	wrist pitch (J5)	Nm
	wrist roll (J6)	Nm
Tolerable inertia	wrist twist (J4)	kgm ²
	wrist pitch (J5)	kgm ²
	wrist roll (J6)	kgm ²
Tool wiring	Hand input 8 points/hand output 8 points	
Tool pneumatic pipes	Ø 6x2 for robot connection (Ø4x8 from base portion to forearm)	
Supply pneumatic pressure		MPa
Gripper flange	ISO 9409-1-31.5	
Protection rating	IP67 (Optional clean room model available)	
Robot controller	CR800-D	CR800-R + R16RTCPU
Order information	Art. no.	
	313089	314056

Dimensions and movement ranges

Robot arms RV-4FRLM

RV-4FRL

1 Robots

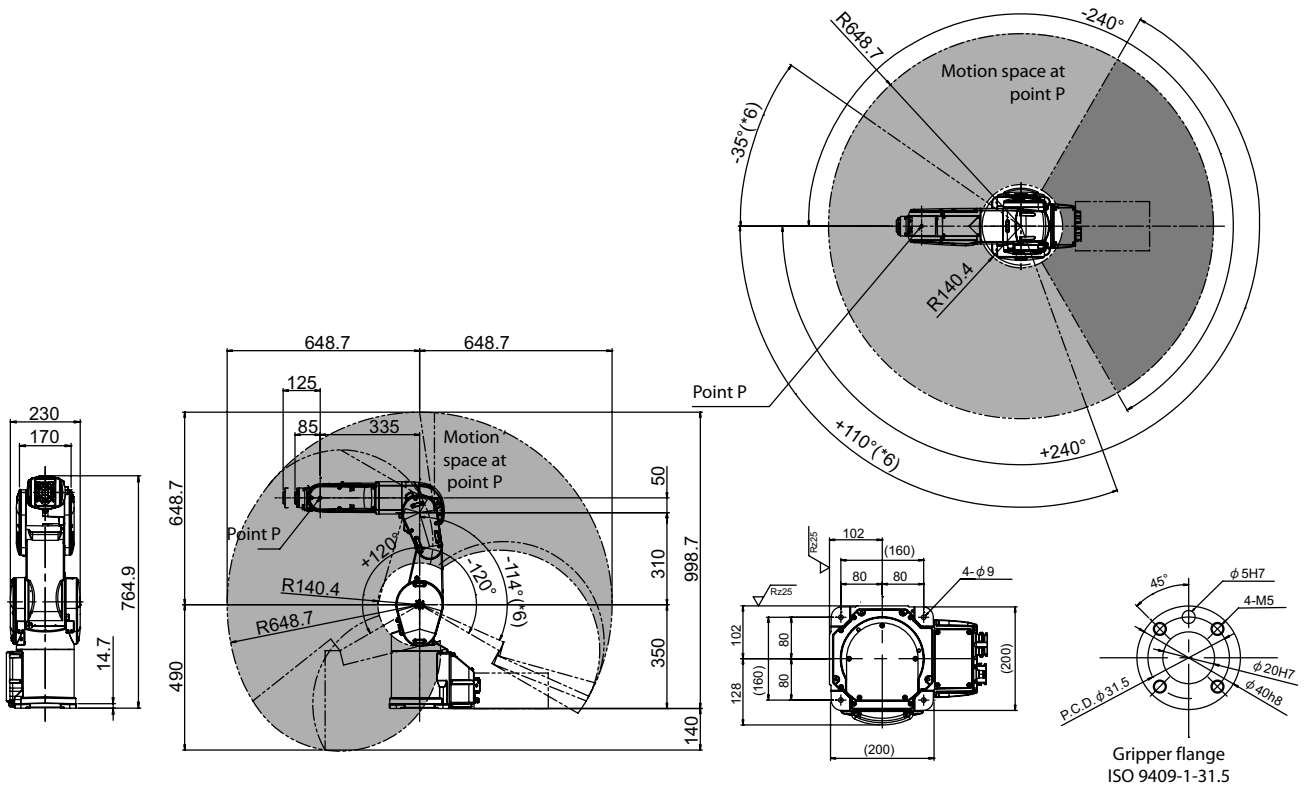

Dimensions: mm

Industrial robots RV-7FRM/7FRLM/7FRLLM



RV-7FRLM

The articulated arm robots RV-7FRM/7FRLM/7FRLLM

The RV-7FRM with a nominal and maximum payload of 7 kg sets new benchmark standards for speed, flexibility, ease of integration and simplicity of programming. For an optimum work radius the robot is available in three versions with ranges from 713 mm to 1503 mm. Ethernet, USB, tracking, camera connection and additional axis connections are standard in all MELFA Robot Series.

Highlights:

- Cycle time of only 0.32 s (RV-7FRM) for a 12-inch cycle
- Drastically increased working range for J1 and J4 axis for a maximum working area
- Internal wiring
- IP67 protection
- Workspace radius of up to 1503 mm (RV-7FRLLM)

Characteristics/Functions	Specifications			
	RV-7FRM-D/ RV-7FRM-R	RV-7FRLM-D/ RV-7FRLM-R	RV-7FRLLM-D RV-7FRLLM-R	
Degrees of freedom (no. of axes)	6			
Installation posture	Floor, ceiling or wall mounting possible (wall mounting with limitations in the J1 axis)			
Structure	Vertical multiple-joint type			
Drive system	AC servo (brakes on all axes)			
Position detection method	Absolute encoder			
Payload capacity	maximum	kg	7	
Arm reachable radius (to the center point of the J5 axis)	mm	713	908	
Operating range	waist (J1)	480 (±240)	380 (±190)	
	shoulder (J2)	240 (-115–125)	240 (-110–130)	
	elbow (J3)	156 (0–156)	162 (0–162)	
	wrist twist (J4)	400 (±200)		
	wrist pitch (J5)	240 (-120–120)		
	wrist roll (J6)	720 (±360)		
Maximum speed	waist (J1)	360	288	
	shoulder (J2)	401	321	
	elbow (J3)	450	360	
	wrist twist (J4)	337		
	wrist pitch (J5)	450		
	wrist roll (J6)	720		
Maximum composite speed	mm/s	11064	10977	
Cycle time (25x300x25 mm with 1 kg load)	sec	0.32	0.35	
Position repeatability	mm	±0.02	±0.06	
Ambient temperature	°C	0–40		
Weight	kg	65	67	
Tolerable moment	wrist twist (J4)	16.2		
	wrist pitch (J5)	16.2		
	wrist roll (J6)	6.86		
Tolerable inertia	wrist twist (J4)	0.45		
	wrist pitch (J5)	0.45		
	wrist roll (J6)	0.10		
Tool wiring	Hand input 8 points/hand output 8 points			
Tool pneumatic pipes	Ø 6x2 for robot connection (Ø4x8 from base portion to forearm)			
Supply pneumatic pressure	MPa	0.54 (as overpressure if required)		
Gripper flange	ISO 9409-1-31.5			
Protection rating	IP67 (Optional clean room model available)			
Robot controller	CR800-D/CR800-R + R16RTCPU			
Order information	Art. no.	313091/ 314058	313093/ 314060	313095/ 314062

Dimensions and movement ranges

Robot arms RV-7FRM/7FRLM/7FRLLM

Robots

RV-7FRM

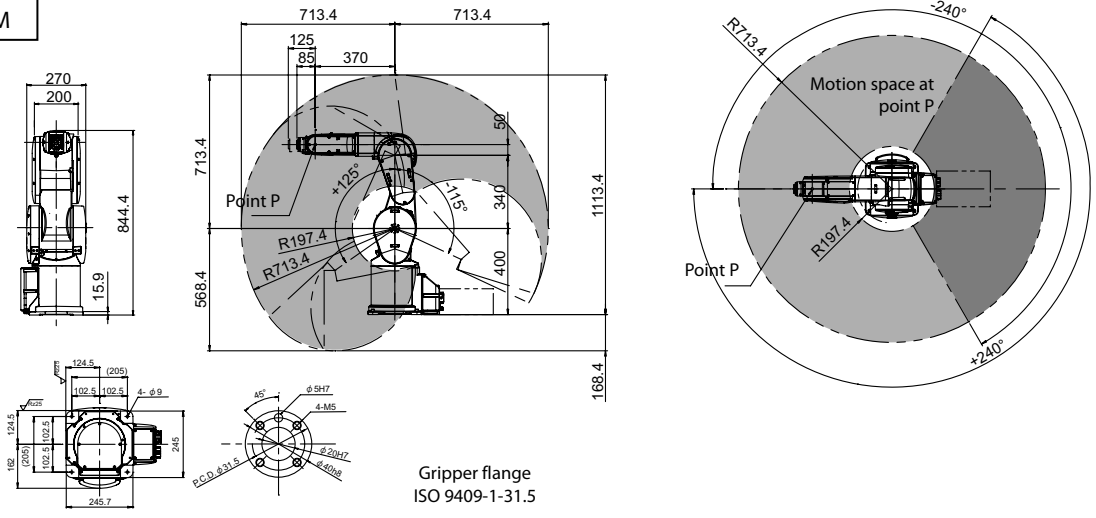

RV-7FRLM

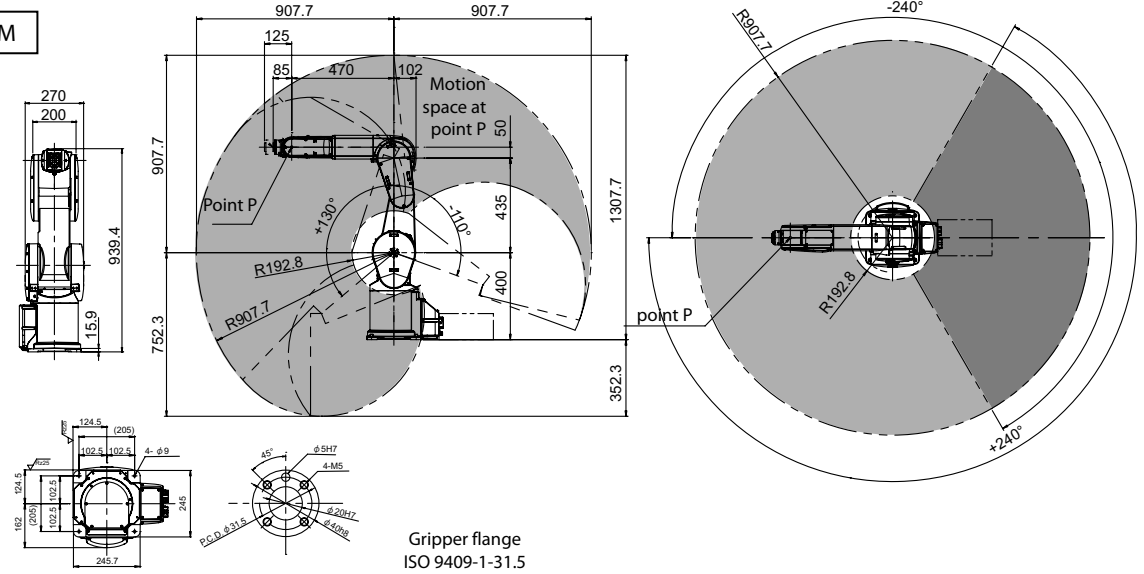

RV-7FRLLM

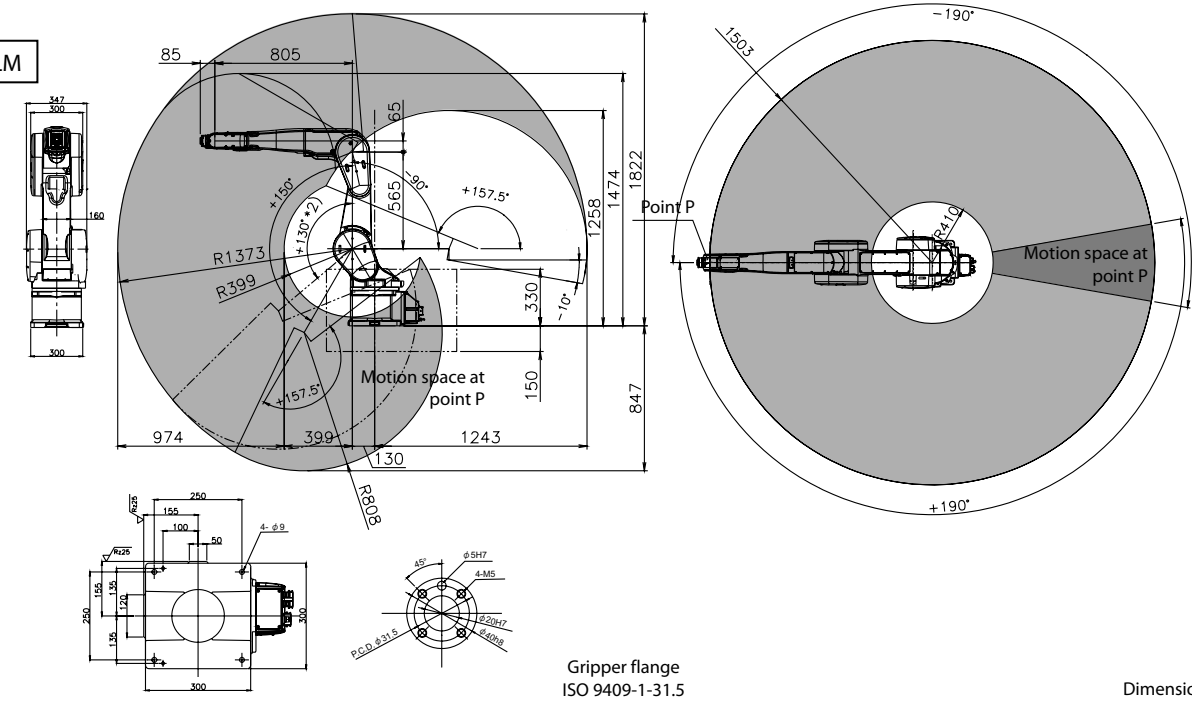

Dimensions: mm

Industrial robots RV-13FRM/RV-13FRLM/RV-20FRM



RV-20FRM

The articulated arm robots RV-13FRM/RV-13FRLM/RV-20FRM

The high-performance robots RV-13 and RV-20 are specially suited for handling heavy loads. Due to the compact body and slim arm design, the robots can operate in a large work area. The anti-collision function of the iQ Platform models prevents collisions between robots which are working close together.

Highlights:

- internal routing of cables and air hoses through the robot arm
- New gears for quiet, precise positioning and movement
- maximum payload of 20 kg (RV-20FRM)
- Protection rating IP67 standard

Characteristics/Functions	Specifications			
	RV-13FRM-D RV-13FRM-R	RV-13FRLM-D RV-13FRLM-R	RV-20FRM-D RV-20FRM-R	
Degrees of freedom (no. of axes)	6			
Installation posture	Floor, ceiling or wall mounting possible (wall mounting with limitations in the J1 axis)			
Structure	Vertical multiple-joint type			
Drive system	AC servo (all axes with brakes)			
Position detection method	Absolute encoder			
Payload capacity	rated	12	15	
	maximum	13	20	
kg				
Arm reachable radius (to the center point of the J5 axis)	mm	1094	1388	
Operating range	waist (J1)	380(±190)		
	shoulder (J2)	240 (-90–150)		
	elbow (J3)	167.5 (-10–157.5)		
	wrist twist (J4)	400 (±200)		
	wrist pitch (J5)	240 (-120–120)		
	wrist roll (J6)	720 (±360)		
Maximum speed	waist (J1)	290	234	
	shoulder (J2)	234	164	
	elbow (J3)	312	219	
	wrist twist (J4)	375	124	
	wrist pitch (J5)	375	125	
	wrist roll (J6)	720	360	
degree/s				
Maximum composite speed	mm/s	10450	9700	
Cycle time (25x300x25 mm with 1 kg load)	sec	0.53	0.68	
Position repeatability	mm	±0.05		
Ambient temperature	°C	0–40		
Weight	kg	120	130	
Tolerable moment	wrist twist (J4)	19.3	49.0	
	wrist pitch (J5)	19.3	49.0	
	wrist roll (J6)	11		
Tolerable inertia	wrist twist (J4)	0.47	1.40	
	wrist pitch (J5)	0.47	1.40	
	wrist roll (J6)	0.14		
kgm ²				
Tool wiring	Hand input 8 points / hand output 8 points			
Tool pneumatic pipes	Primary: Ø 6x2, secondary: Ø 6x8			
Supply pneumatic pressure	MPa	0.54 (as overpressure if required)		
Gripper flange	ISO 9409-1-40			
Protection rating	IP67 (Optional clean room model available)			
Robot controller	CR800-D/CR800-R + R16RTCPU			
Order information	Art. no.	313097/ 314064	313099/ 314066	312663/ 314068

Dimensions and movement ranges

Robot arms RV-13FRM/RV-13FRLM/RV-20FRM

RV-13FRM/20FRM/13FRLM

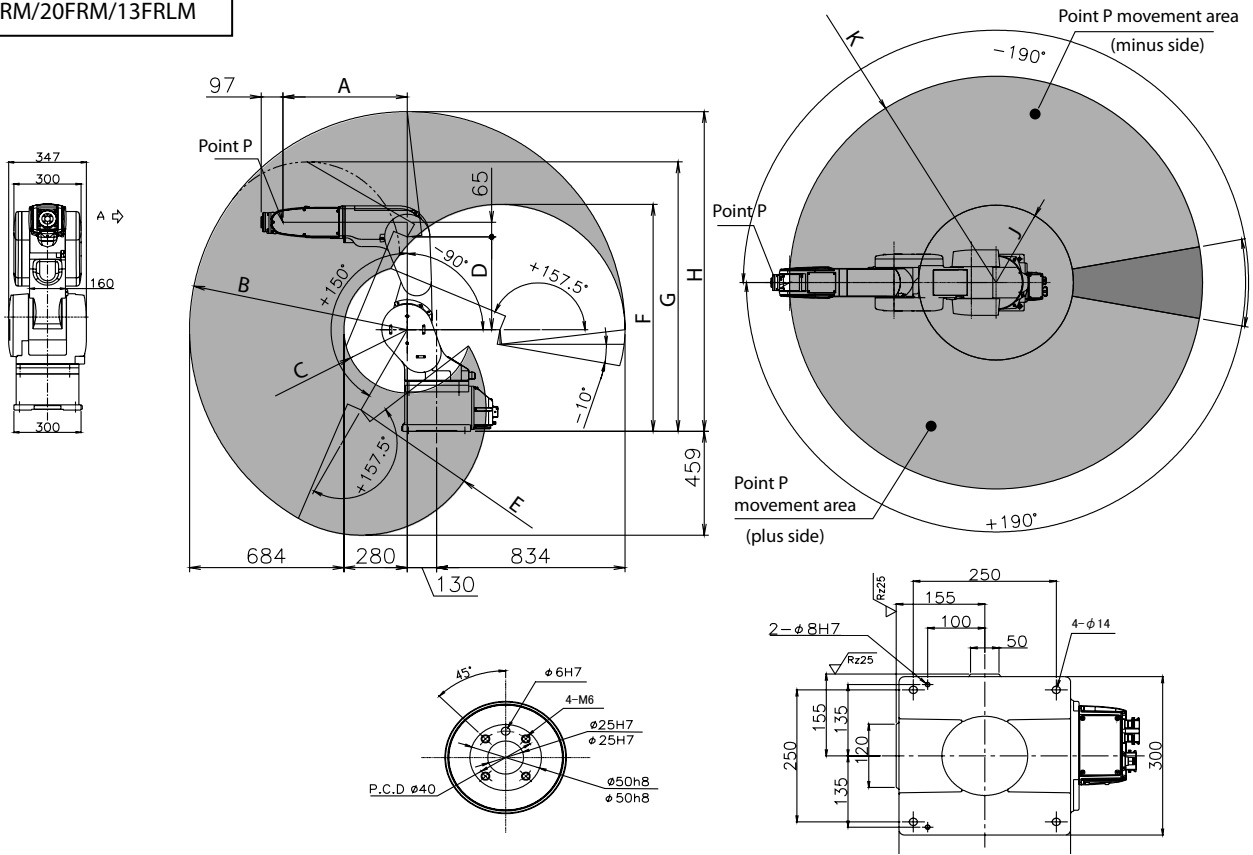

Dimensions: mm

Variable dimensions

Robot series	A	B	C	D	E	F	G	H	J	K
RV-13FRM/20FRM	550	R964	R280	410	R554	1004	1191	1414	R410	R1094
RV-13FRLM	690	R1258	R328	565	R693	1143	1416	1708	R458	R1388

Industrial robots RV-35F/RV-50F/RV-70F



RV-35F/RV-50F/RV-70F

High capacity robots RV-35F/RV-50F/RV-70F

These robots with payload from 35 kg up to 70 kg are addressing applications that require higher payloads and longer reaches, including CNC machine tending, large material handling, palletizing and end of line packaging.

Highlights:

- Long reach arm up to 2050 mm for tasks can be spread farther apart and can accommodate larger parts and processes
- Multiple environmental protection ratings – available in IP40 and IP67 protection ratings for various application requirements
- Seamless integration in the Mitsubishi Electric automation world

Characteristics/Functions	Specifications		
	RV-35F ^①	RV-50F ^①	RV-70F ^①
Degrees of freedom (no. of axes)	6		
Installation posture	Floor		
Structure	Vertical multiple-joint type		
Drive system	AC servo (all axes with brakes)		
Position detection method	Absolute encoder		
Payload capacity	kg	35	50
Arm reachable radius (to the center point of the J5 axis)	mm	2050	
Operating range	waist (J1)	330(±165)	
	shoulder (J2)	215 (-80–135)	
	elbow (J3)	261(-90–171)	
	wrist twist (J4)	720 (±360)	
	wrist pitch (J5)	250 (±125)	
	wrist roll (J6)	900 (±450)	
Maximum speed	waist (J1)	185	180
	shoulder (J2)	180	180
	elbow (J3)	190	180
	wrist twist (J4)	305	255
	wrist pitch (J5)	305	255
	wrist roll (J6)	420	370
Maximum composite speed	mm/s	13450	13000
Position repeatability	mm	±0.07	
Ambient temperature	°C	0–40	
Weight	kg	640	
Tolerable moment	wrist twist (J4)	160	210
	wrist pitch (J5)	160	210
	wrist roll (J6)	90	130
Tolerable inertia	wrist twist (J4)	16	30
	wrist pitch (J5)	16	30
	wrist roll (J6)	5	12
Tool wiring	16 input points/16 output points		
Tool pneumatic pipes	Ø 10x2		
Supply pneumatic pressure	MPa	Max. 0.49	
Protection rating	IP67		
Robot controller	CR760 ^①		
Order information	Art. no.	On request	On request

① Please contact your Mitsubishi Electric representative for more details.

Dimensions and movement ranges

Robot arms RV-35F/RV-50F/RV-70F

RV-35F/RV-50F/RV-70F

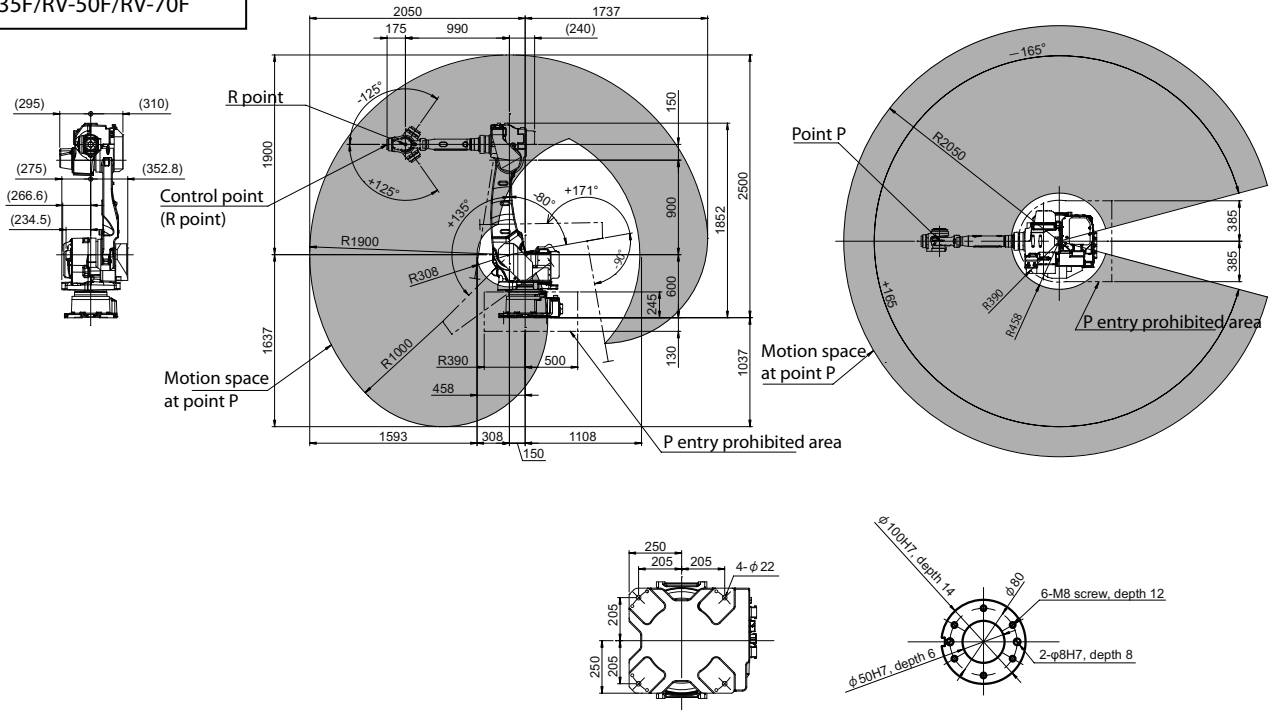

Dimensions: mm

Industrial robots RP-1ADH/RP-3ADH/RP-5ADH



RP-5ADH

The SCARA robots RP-1ADH, RP-3ADH and RP-5ADH

The RP-1ADH, RP-3ADH and RP-5ADH SCARA robots are in their element in all applications calling for fast and precise placement of components in limited space. The unique mechanical design of these robots gives them a significant edge for improved productivity and micro-handling quality.

Highlights:

- Repeatability ± 0.005 mm (RP-1ADH)
- Footprint just 200x160 mm (RP-1ADH)
- Pick & Place cycle time <0.5 s
- unique concept

Characteristics/Functions	Specifications		
	RP-1ADH	RP-3ADH	RP-5ADH
Degrees of freedom (no. of axes)	4		
Installation posture	Floor mounting		
Drive system	AC servo		
Position detection method	Absolute encoder		
Brake attachment	All axes		
Payload capacity	rated	1.0	2.0
	maximum	3.0	5.0
Operating range	width depth	150x105 (DIN-A6)	297x210 (DIN-A4)
	vertical	30	50
	twist	± 200	
Maximum speed	J1/J2	480	432
	J3	800	960
	J4	3000	1330
Cycle time (25 x 100 x 25 mm)	0.28	0.33	1230
Inertial moment	wrist	3.10×10^{-4}	1.60×10^{-3}
			3.20×10^{-3}
Position repeatability	X, Y direction	± 0.005	± 0.008
	Z direction	± 0.01	± 0.01
	direction of the wrist twist	± 0.02	± 0.03
Ambient temperature	$^{\circ}\text{C}$ 0–40		
Weight	12	24	25
Tool wiring	8 inputs/8 outputs		
Supply pneumatic pressure	0.5 \pm 10 %		
Robot controller	CR1DA		
Order information	Art. no.	252843	252844
			252885

Dimensions and movement ranges

Robot arms RP-1ADH/RP-3ADH/RP-5ADH

RP-1ADH

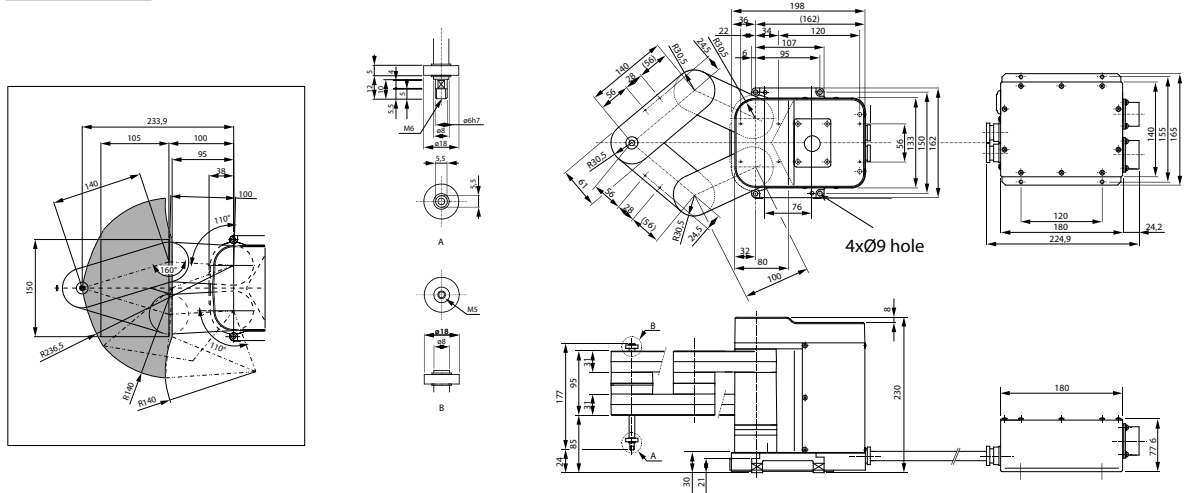

RP-3ADH/RP-5ADH

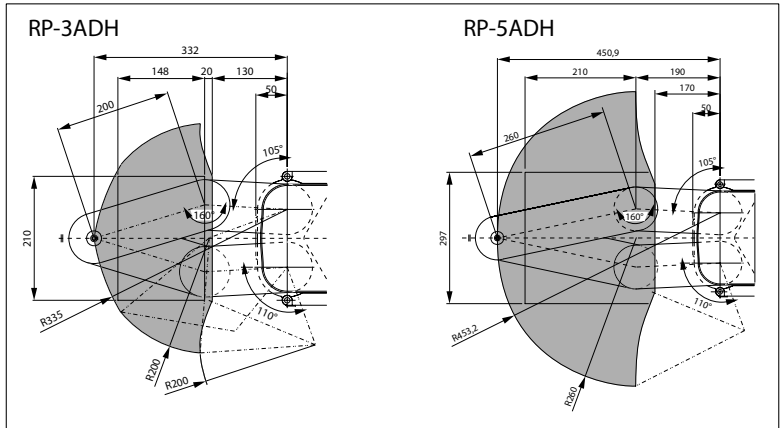
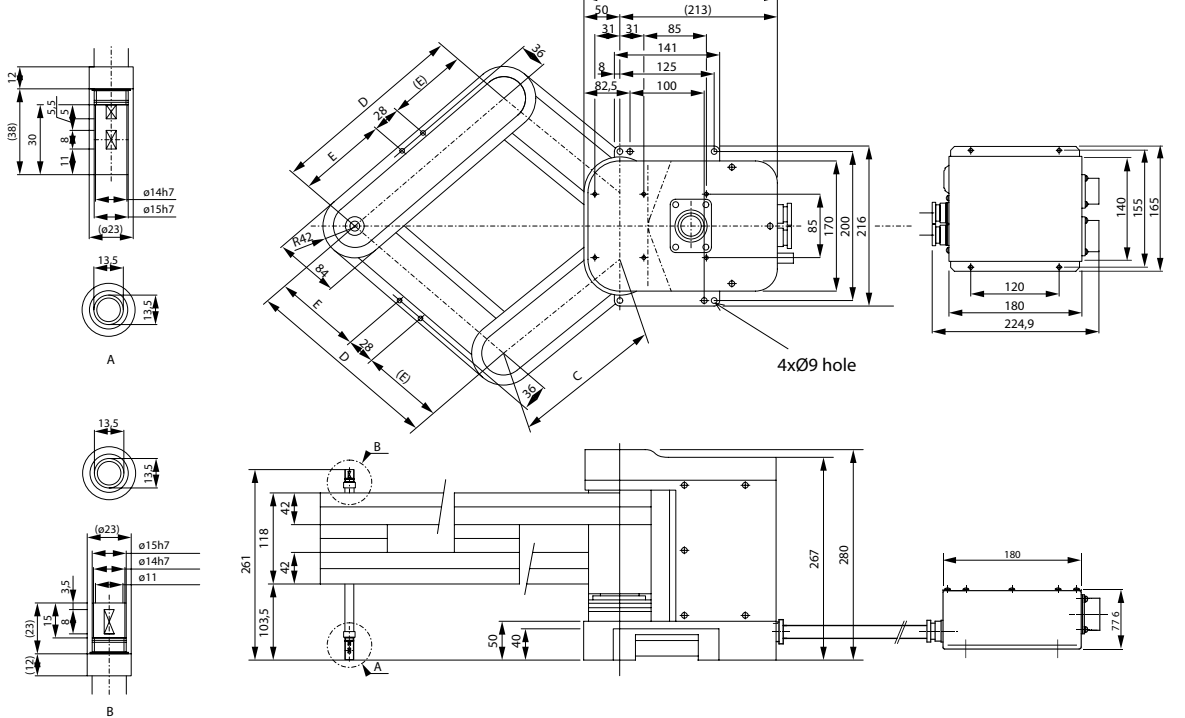

Variable dimensions

Robot series	C	D	E
RP-3ADH	140	200	86
RP-5ADH	200	260	116

Dimensions: mm

Industrial robots RH-1FRHR



SCARA robot for overhead installation

With its special compact design and support for overhead installation above the application, the robot RH-1FRHR doesn't take up any valuable space in the work area next to the installation location, enabling even smaller work cell dimensions.

The RH-1FRHR5515 is a high-speed robot dedicated for handling of small parts up to 1 kg. Up to 150 picks/min with conveyor tracking including hand open/close are possible.

Highlights:

- High-speed 4 axis robots for fastest pick and place (cycle times of only 0.28 s)
- Up to 150 picks/min. with conveyor tracking including hand open/close
- Space saving and flexible installation method
- Optional integrated vacuum valve and bellow for highest requirements in pharmaceutical and F&B application

Characteristics/Functions	Specifications		
	RH-1FRHR5515-D	RH-1FRHR5515-R	
Degrees of freedom (no. of axes)	4		
Installation posture	On floor, ceiling mounting, wall mounting		
Structure	Horizontal articulated arm (SCARA)		
Drive system	AC servo		
Position detection method	Absolute encoder		
Brake attachment	Axes J1, J2, J4: no brake; axis J3: with brake		
Payload capacity	rated	1	
	maximum	3	
Maximum reach	mm	550	
Operating range	J1	degree	±177
	J2	degree	±145
	J3 (Z)	mm	150
	J4 (θ axis)	degree	±360
Maximum speed	J1	degree/s	337.5
	J2	degree/s	720
	J3 (Z)	mm/s	765
	J4 (θ axis)	degree/s	3000
Maximum composite speed	mm/s	6267	
Cycle time (25x300x25 mm with 1 kg load)	sec	0.28	
Allowable wrist moment of inertia	rated	kgm ²	0.005
	maximum		0.005
Position repeatability	X, Y direction	mm	±0.012
	J3 (Z direction)	mm	±0.01
	J4 (θ axis)	degree	±0.004
Ambient temperature	°C	0-40	
Weight	kg	49	
Tool wiring	Hand: 8 inputs/8 outputs, 8 signal cables		
Tool pneumatic pipes	Primary: Ø 6x2 (secondary: Ø 4x8 by option)		
Supply pneumatic pressure	MPa	5 ±10 % for the pneumatic gripper	
Protection rating	IP20 (IP65/ISO class 5 with additional bellow)		
Robot controller	CR800-D	CR800-R + R16RTCPU	
Order information	Art. no.	312997	313661

Dimensions and movement ranges

Robot arms RH-1FRHR

RH-1FRHR

1 Robots

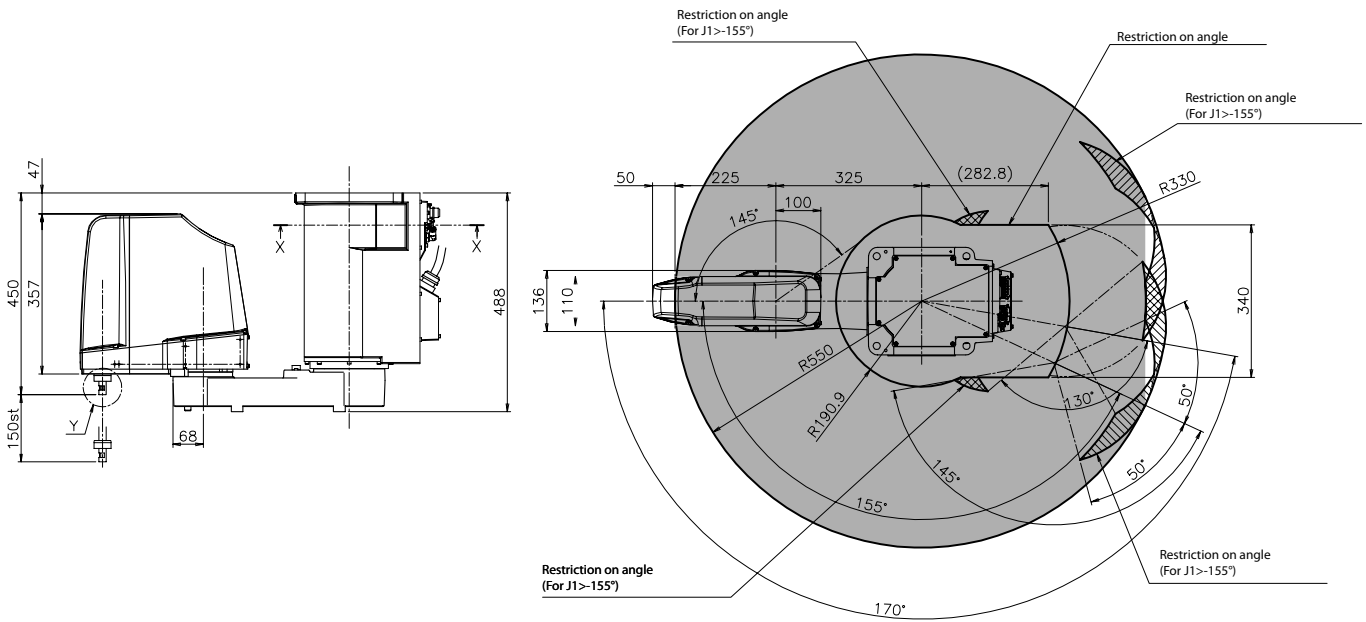

Dimensions: mm

Industrial robots RH-3FRHR



RH-3FRHR

The SCARA robots RH-3FRHR

With its special compact design and support for overhead installation above the application, the robot RH-3FRHR doesn't take up any valuable space in the work area next to the installation location, enabling even smaller work cell dimensions. The robot's perfectly circular cylindrical work space is 150 mm high with a diameter of 700 mm. It can access any point in this space with a repeatability of just ± 0.01 mm while manipulating a payload of up to 3 kg.

Highlights:

- Overhead installation for minimum space requirements
- Only 24 kg weight
- Cycle times of only 0.32 s
- High stability due to compact design
- Pneumatic hoses and signal wires are routed inside the robot

Characteristics/Functions	Specifications	
	RH-3FRHR3515-D-S25	RH-3FRHR3515-R-S25
Degrees of freedom (no. of axes)	4	4
Installation posture	Overhead	
Structure	Horizontal multiple-joint type	
Drive system	AC servo	
Position detection method	Absolute encoder	
Brake attachment	Axes J1, J2, J4: no brake; axis J3: with brake	
Payload capacity	rated	kg
	maximum	1
Maximum reach	arm 1 + arm 2	mm
		350
Operating range	J1	degree
	J2	degree
	J3 (Z)	mm
	J4 (θ axis)	degree
Maximum speed	J1	degree/s
	J2	degree/s
	J3 (Z)	mm/s
	J4 (θ axis)	degree/s
Maximum composite speed	mm/s	6267 (J1, J2)
Cycle time (25x300x25 mm with 1 kg load)	sec	0.32
Allowable wrist moment of inertia	rated	kgm ²
	maximum	0.005
Position repeatability	X, Y direction	mm
	J3 (Z direction)	mm
	J4 (θ axis)	degree
		± 0.01
Ambient temperature	°C	0–40
Weight	kg	24
Tool wiring	Input 8 points/output 8 points (option: output 8 points), 8 spare wires	
Tool pneumatic pipes	Primary: \varnothing 6x2 (secondary: \varnothing 4x8 by option)	
Supply pneumatic pressure	MPa	5 \pm 10 % for the pneumatic gripper
Protection rating	IP20 (Optional IP65 and clean room model available)	
Robot controller	CR800-D	CR800-R + R16RTCPU
Order information	Art. no.	312998
		314028

Dimensions and movement ranges

Robot arms RH-3FRHR

RH-3FRHR

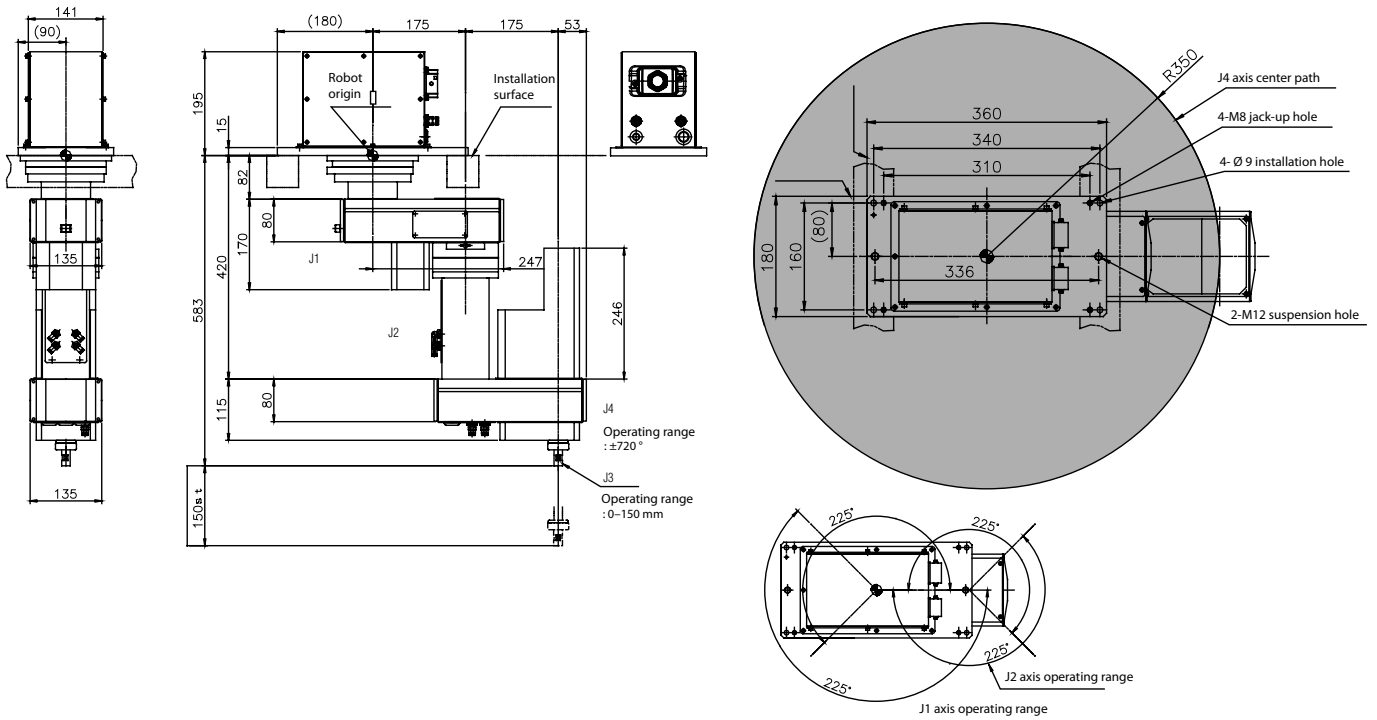

Dimensions: mm

Industrial robots RH-FRH



The SCARA robots RH-FRH

SCARA robots are ideal for sorting, palletising and component installation due their short cycle time. The robots of the RH-FRH series achieve the highest speeds in their class thanks to the new motors developed by Mitsubishi Electric, high arm rigidity and unique control technology.

The resulting reduced cycle time of only 0.29 seconds for a 12" cycle make for significantly increased productivity and improved continuous operation.

Highlights:

- Connections for pneumatic grippers, Ethernet, USB, tracking functions, camera interface, hand I/O, additional axis controller and an interface for GOT HMIs
- Fully enclosed cabling to end of spindle for protection and safety
- RH-6/12/20FRH has the tried-and-tested protection class IP54 (IP65 optional)

Characteristics/Functions	Specifications			
	RH-3FRH3515-D/ RH-3FRH5515-R	RH-6FRH5520N-D/ RH-6FRH5520N-R	RH-12FRH8535N-D/ RH-12FRH8535N-R	RH-20FRH10035N-D/ RH-20FRH10035N-R
Degrees of freedom (no. of axes)	4	4	4	4
Installation posture	Floor mounting			
Structure	Horizontal multiple-joint type			
Drive system	AC servo			
Position detection method	Absolute encoder			
Brake attachment	Axes J1, J2, J4: no brake; axis J3: with brake			
Payload capacity	rated	1	3	5
	maximum	3	6	20
Maximum reach	arm 1 + arm 2	550	550	1000
		mm		
Operating range	J1	340 (±170)		
	J2	290 (±145)		306 (±153)
	J3 (Z)	150	200	350
	J4 (θ axis)	720 (±360)		
Maximum speed	J1	400	400	280
	J2	720	670	450
	J3 (Z)	1100	2400	2800
	J4 (θ axis)	3000	2500	2400
Maximum composite speed	8300	8300	11350	13283
Cycle time (25x300x25 mm with max. 2 kg load)	0.51	0.29	0.30	0.36
Allowable wrist moment of inertia	rated	0.005	0.01	0.025
	maximum	0.06	0.12	0.3
Position repeatability	X, Y direction	±0.012	±0.012	±0.015
	J3 (Z direction)	±0.010		
	J4 (θ axis)	±0.004		±0.005
Ambient temperature	°C 0–40			
Weight	32	37	69	77
Tool wiring	Input 8 points/output 8 points (total 20 scores)			
Tool pneumatic pipes	Primary: Ø 6x2, secondary: Ø 4x8			
Supply pneumatic pressure	MPa 5 ±10 % for the pneumatic gripper			
Protection rating	IP20			
Robot controller	IP54 (IP65 with additional bellow, optional clean room model available)			
	CR800-D/CR800-R + R16RTCPU			

Order information	Art. no.	312930/ 313651	312985/ 313666	312991/ 313672	312995/ 313676
-------------------	----------	-------------------	-------------------	-------------------	-------------------

Dimensions and movement ranges

Robot arms RH-FRH

RH-3FRH

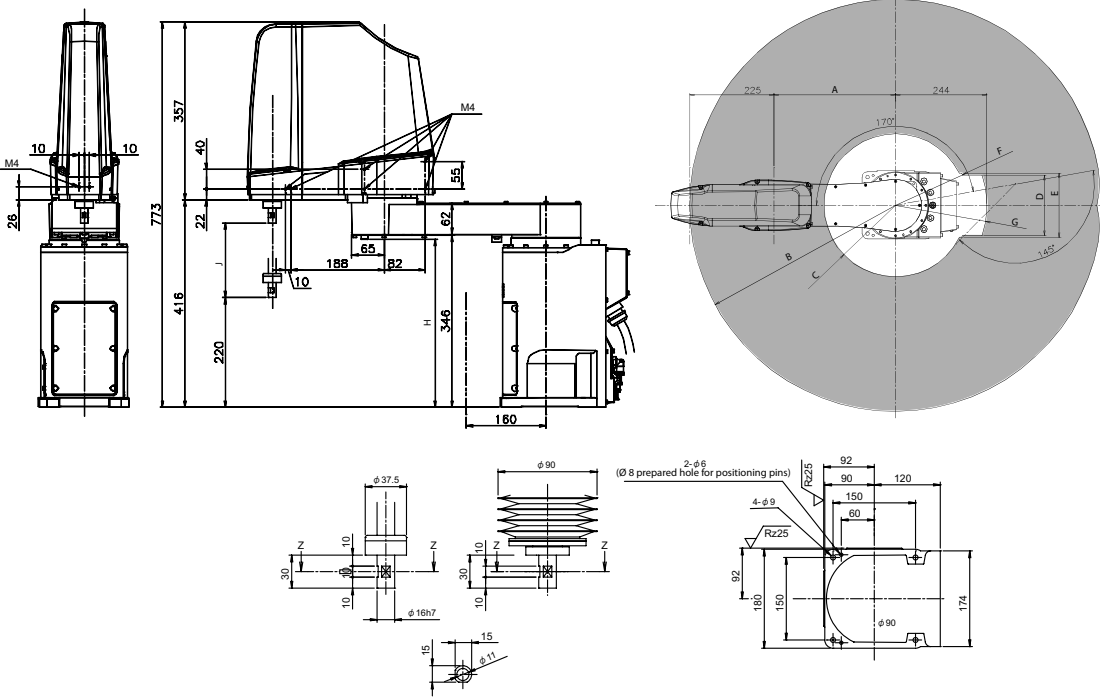

Dimensions: mm

Variable dimensions

Robot series	A	B	C	D	E	F	G	H	J
RH-3FRH515	125	R550	R142	210	R253	220	R174	342	150

RH-6FRH

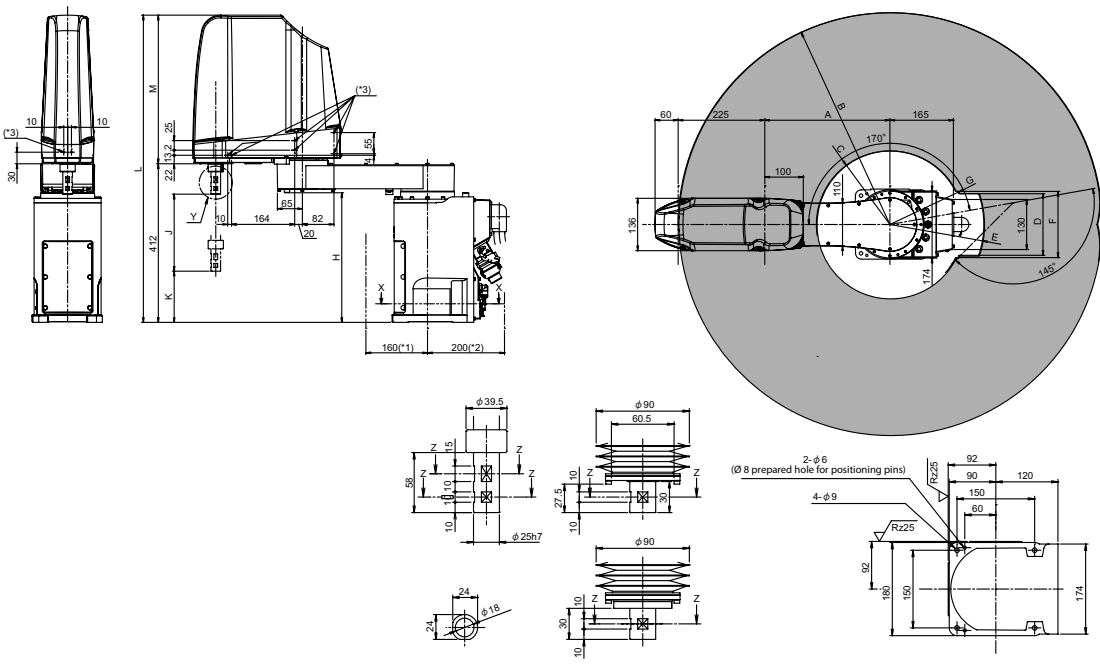

Dimensions: mm

Variable dimensions

Robot series	A	B	C	D	E	F	G	H	J	K	L	M
RH-6FRH520	325	R550	R191	160	R244	172	R197	337	200	133	798	386

RH-12FRH/20FRH

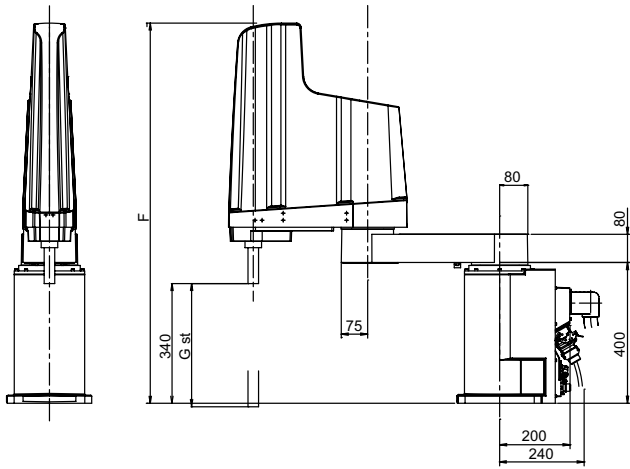

RH-12FH

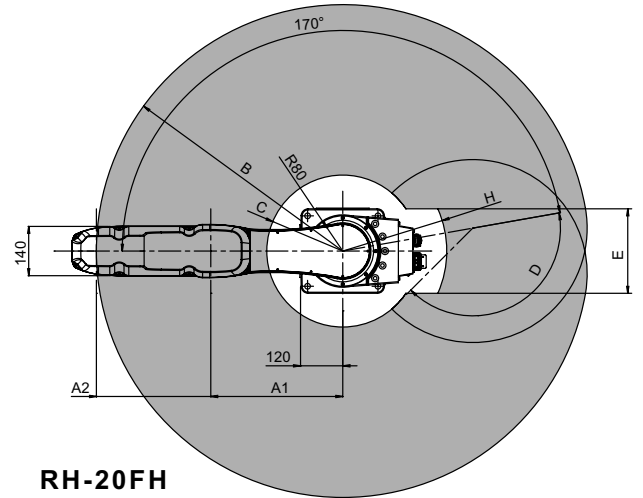

RH-20FH

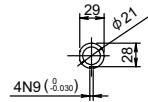
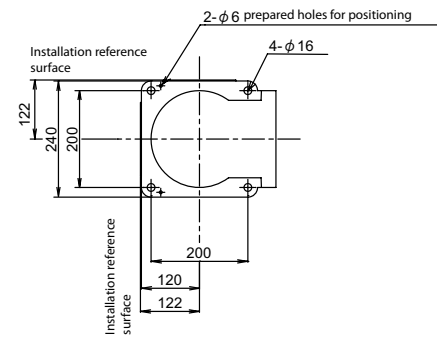
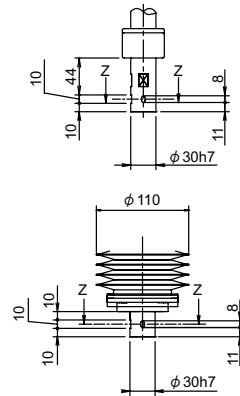
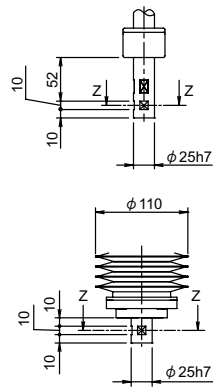

Dimensions: mm

Variable dimensions

Robot series	A1	A2	B	C	D	E	F	G	H
RH-12FRH/20FRH85□	525	325	R850	R278	153°	—	1080/1180	350/340	—
RH-20FRH100□	525	475	R1000	R238	153°	240	1080/1180	350/340	R295

Industrial robots RD-1F500/RD-1F800/RD-1F1100/RD-1F1300



RD-1F800

Delta robots

When items to be picked and placed for packing and assembly are relatively lightweight with simple geometries, then delta robots can offer an effective and reliable high quality, high speed solution. Users can take the advantage of Mitsubishi Electric's highly dynamic servo technology to drive the parallel kinematic axis, and control via Mitsubishi Electric's standard robot controller.

Highlights:

- Lightweight and simple construction for high speed pick-and-place applications.
- Seamless integration in Mitsubishi Electric robot controller
- Fully integrated in RT Toolbox3 inclusive simulation
- Dedicated HD models with IP69K and stainless steel for F&B industry

Characteristics/Functions	Specifications			
	RD-1F500 ①	RD-1F800 ①	RD-1F1100 ①	RD-1F1300 ①
Degrees of freedom (no. of axes)	4	4	4	4
Installation posture	Ceiling mounting			
Structure	Delta kinematic			
Drive system	AC servo motor (J1/J2/J3: with brake; rotation axis: without brake)			
Position detection method	Absolute encoder			
Payload capacity	rated	1	1	
	maximum	2	3	
Maximum reach	mm	Ø 500x130	Ø 800x250	Ø 1100x250
Cycle time (25x300x25 mm with max. 1 kg load)	sec	Max. 200	Max. 200	Max. 180
Position repeatability	X, Y direction	mm	±0.2	±0.1
	J3 (Z direction)	mm	±0.3	
Ambient temperature	°C	5–45		
Weight	kg	45	80	80
Protection rating		IP65		
Robot controller		CR750 ①		
Order information	Art. no.	On request	On request	On request

① Please contact your Mitsubishi Electric representative for more details.

FR-D series system configuration

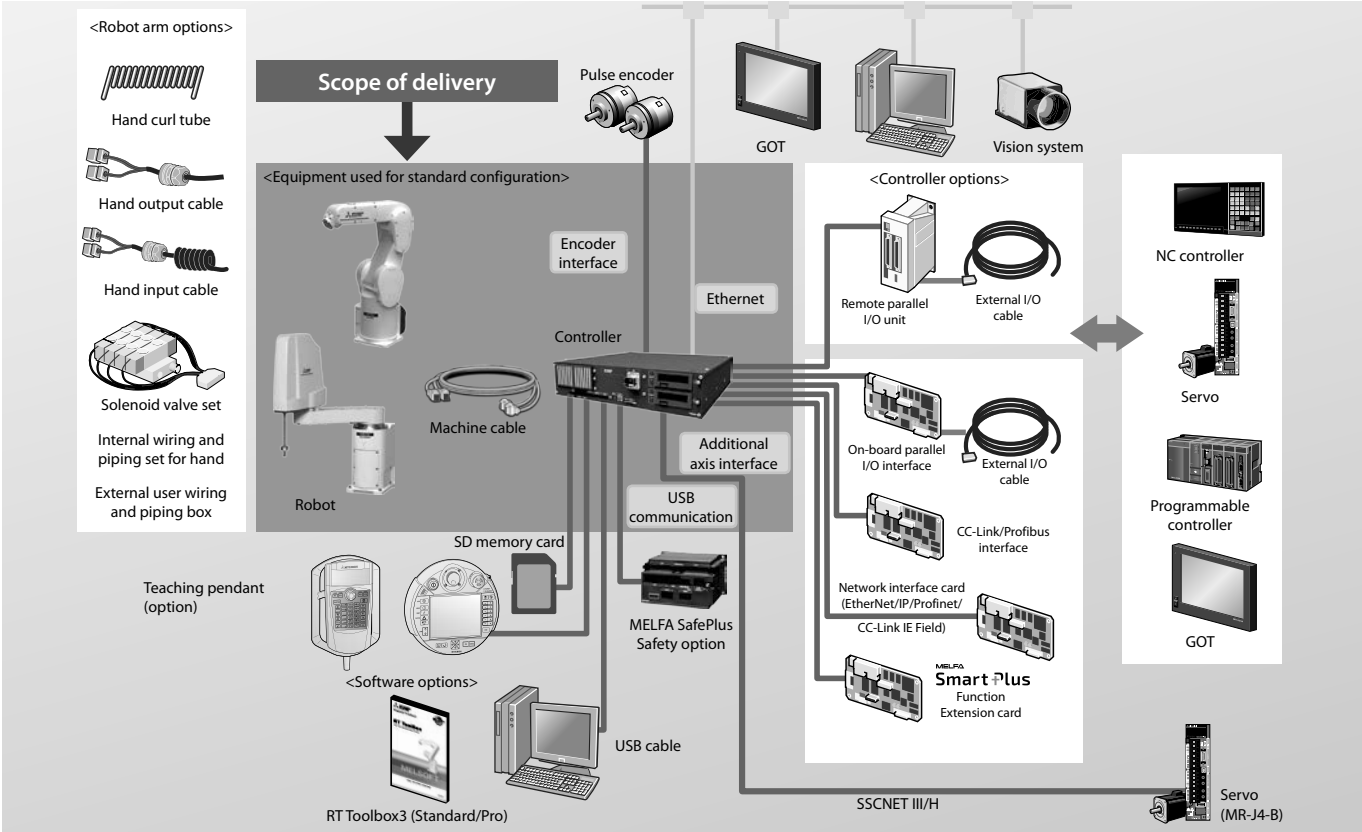

1 Robots

FR-R series system configuration (iQ-R Platform)

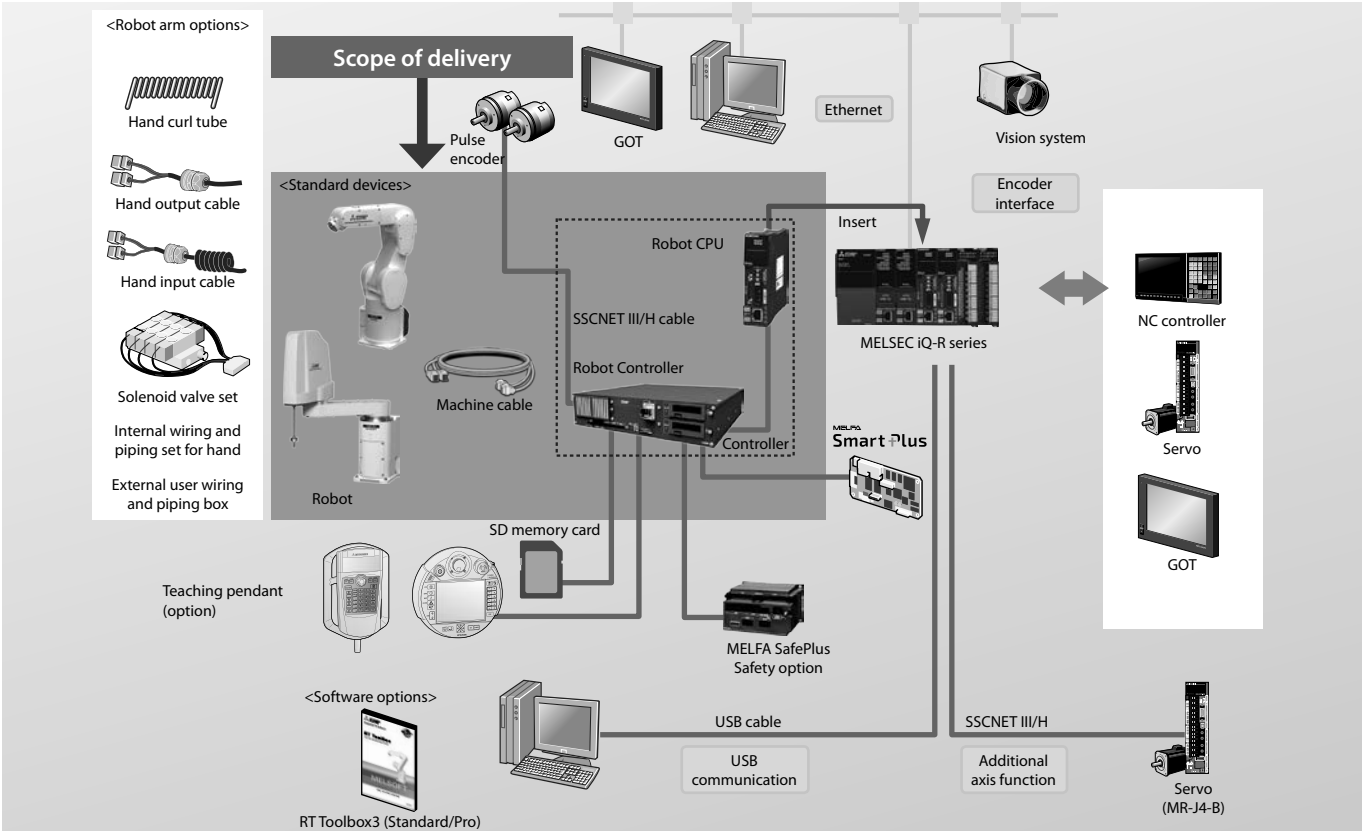

Controller specifications



CR1DA



Controller CR800

Powerful controller

Every robot system has its own compact, modular robot controller, which contains the CPU and the power electronics for controlling the robot.

Mitsubishi Electric's robot controllers have a particularly slim, compact design. No matter which Mitsubishi robot you use the programming language and options are always the same. You can add special application functions by inserting expansion option cards in the slots in the controllers. Therefore it is possible, to integrate the controller into different types of networks.

All controllers have already implemented functions like Ethernet and USB connection, additional axes control over SSCNET III/H and tracking encoder interface as a standard.

The control unit CR800 also includes the input and output card for the connection of a pneumatic or electric gripper.

Characteristics/Functions	CR800-D	CR800-R	CR1DA	
Shipped with robot	RV-2FR/2FRL/4FR/4FRL/7FR/7FRL/7FRL/13FR/13FRL/20FR RH-1FHR/3FRHR/3FRH/6FRH/12FRH/20FRH		RP-1ADH/3ADH/5ADH	
Robot CPU	—	R16RTCPU	—	
Path control method	PTP control and CP control			
Number of controllable axes	6 robot axes + 2 interpolation axes + 6 independent axes			
Programming language	MELFA-BASIC V/VI		MELFA-BASIC IV/V	
Position teaching method	Teaching method, MDI method			
Memory capacity	no. of teaching points	39000	13000	
	no. program steps	78000	26000	
	no. of programs	512	256	
External inputs/outputs	general purpose I/Os	Up to 256 optional	Up to 256	
	dedicated I/Os	Assigned to general-purpose I/O	Assigned to multiple CPU common device	
	hand open/close	8 inputs/8 outputs	8 inputs/0 outputs	
	emergency stop I/Os	1 (redundant)		
	door switch input	1 (redundant)		
	enabling device input	—	1 (redundant)	
	mode output	1 (redundant)		
	robot error output	1 (redundant)		
synchronization of additional axes	1 (redundant)			
Ethernet	1 (10BASE-T/ 100BASE-TX/1000BASE-T)		1 (10BASE-T/100BASE-TX)	
USB	1 (Ver. 2.0 device functions only, mini B terminal)	1 (USB port of programmable controller CPU unit can be used.)	1 (Ver. 2.0 device functions only, mini B terminal)	
SD Memory slot	1	1	—	
Ambient temperature	°C 0–40	0–40 (controller)/0–55 (Robot CPU)	0–40	
Relative humidity	% RH 45–85			
Power supply	input voltage range	RV-2F(L)/4F(L)/7F(L), RH-1FRHR/3FRH/3FRHR/6FRH/12FRH/20FRH: 1-phase 180–253 V AC RV-7FRL/13FR(L)/20FR: 3-phase 180–253 V AC or 1-phase 207–253 V AC		RP-1/3/5ADH, RH-3SDHR: 1-phase 180–253 V AC
	power capacity	RV-2F(L), RH-3FRH: 0.5; RV-4F(L), RH-3FRHR/6FRH: 1.0; RH-1FRHR/12FRH/20FRH: 1.5; RV-7FR(L): 2.0; RV-7FRL/13FR(L)/20FR: 3.0		1.0
Dimensions (WxHxD) including legs	mm 430x99.5x425	430x99.5x425	270x290x200	
Weight	kg 12.5	12.5	9	
Structure (protective specification)	Self-contained floor type/open structure (Vertical and horizontal position can be placed) (IP20) + IP54 protection box available as an option			
Grounding	Ω 100 or less (class D grounding)			

Controller dimensions

CR800

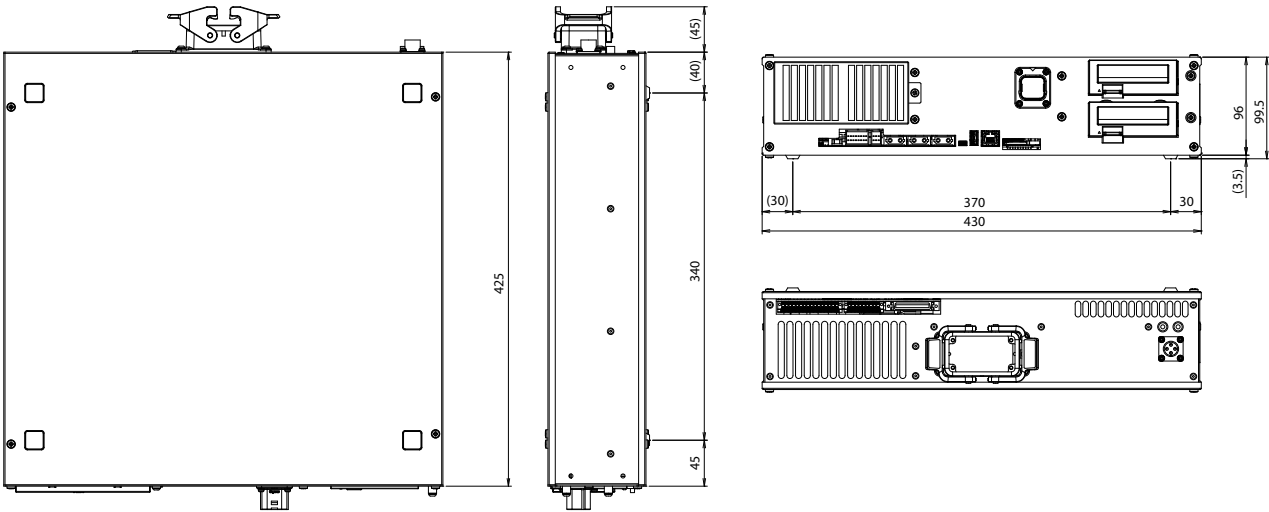

CR1DA

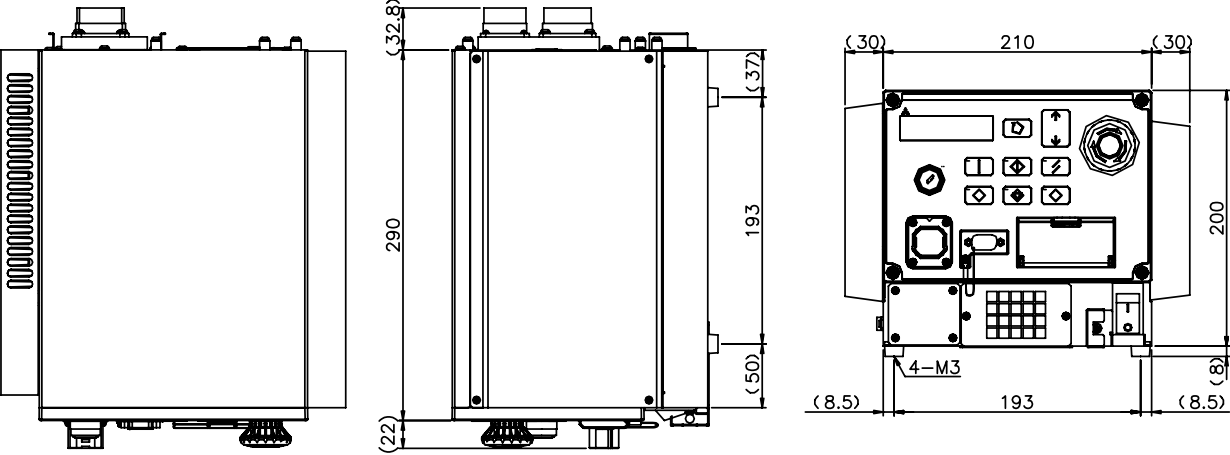

Teaching box for FR series, F series, SD/SQ series and ADH series robots



R56TB



R32TB



R56TB Wall mount

Operation and programming

The R56TB teach panel is a multifunctional control and programming terminal for all Mitsubishi Electric FR series, F series, SD/SQ series and ADH series robots. Its intuitive user interface makes it easy to control robot movements and perform extensive diagnostics and monitoring functions for users of all levels. All safety-critical functions such as robot movements are assigned to keys.

Programming and monitoring functions are accessed and adjusted quickly and easily via the bright 6.5" touchscreen display.

In addition to controlling robot movements the terminal has many other functions: For example, writing programs with a virtual on-screen keyboard and monitoring all system status parameters, inputs and outputs, including those accessed via the network.

A complete backup of the robot can simply be loaded or stored on an USB stick via the R56TB.

Specifications	R56TB	R32TB
Compatibility	All Mitsubishi Electric FR series, F series, SD/SQ series and ADH series robots	
Functions	Operation, programming and monitoring of all robot functions	
Programming and monitoring	Read out information, also during operation; program editing with virtual keyboard; display up to 14 lines of program code; I/O monitoring for up to 256 inputs and 256 outputs; service display with information on maintenance intervals; error display with details of the last 128 alarms	Read out information, also during operation, program editing with T9-Key standard, supervising of I/Os, display of error alarms, right-/left-Hand usage, 36 keys for operation selection
Software	Integrated operating system software with menu-based user interface	
Menu navigation (language)	German, English, French, Italian	English, Japanese
Display	type/dimensions	6.5" TFT display (640x480 pixels)
	technology	Touchscreen with backlight
Interfaces	USB, Ethernet for connection to the robot controller	Monochrome LCD graphic display (24 characters x 8 lines) LCD with backlight
Connection	Direct connection to the robot controller, cable length 7 m	
Protection rating	IP65	RS422 for connection to the robot controller
Weight	kg 1.25	IP65
Order information	Art. no. 218854	214968
Accessories wall mount	Art. no. 204294	274317

Force sensor



Force sensor set

With the force sensor our RV-FR and RH-FR robots can be controlled to reach pre-set values of reaction force and softness when the robot contacts surrounding objects.

Features

- Function for controlling robots while applying a specified force
- Function for controlling the stiffness of robot appendages
- Function for changing control characteristics while the robot is running

- Function for acquiring force sensor and robot positions while contact made
- Function for display force sensor data and maintaining maximum values
- Function for acquiring force sensor information synchronized to position
- Information as log data and displaying it in graph form
- Allows logging start/stop commands to be specified in robot programs
- Function for transferring acquired log files to the FTP server

Specifications	4F-FS002H-W200	4F-FS002H-W1000
Robots	RV-FR and RH-FR	
Controller	CR800-D/R	
Max. static load (Fx, Fy, Fz / Mx, My, Mz)	200N/4Nm	1000N/30Nm
Set includes:	Force sensor, Force sensor interface unit, Sensor attachment adapter, Adapter cable for internal wiring, 24 V DC Power supply incl. 1 m cable, Serial cable between unit and sensor 5 m, SSCNET III cable 10 m	
Order information	Art. no. 313064	313105

MELFA SafePlus



“MELFA SafePlus” safety technology for the FR series robot controllers

Functions like reduced safe speed control, safe limited control range and safe torque monitoring are the main functions which can be activated via safety inputs, as a

result the FR series robots can be easily integrated in safety systems.

Simple safety logic to control safety I/Os can be programmed in the robot controller without using a dedicated Safety PLC.

Specifications	4F-SF002-01
Robots	RV-FR and RH-FR
Controller	CR800-D/R
Redundant safety In-/Outputs	8 inputs / 4 outputs
Order information	Art. no. 313061

MELFA Smart Plus Card



Advanced intelligent functions are provided by MELFA Smart Plus

Integrated functions for the various sensors and autonomous startup adjustment functions are included:

- Robot mechanism temperature compensation function
- Calibration assistance function
- Coordinated control for additional axes

Specifications	2F-DQ510	2F-DQ511
Robots	RV-FR and RH-FR	
Controller	CR800-D/R	
Number of functions enabled	All functions	1 function
Order information	Art. no. 325728	325729

Internal/external wiring

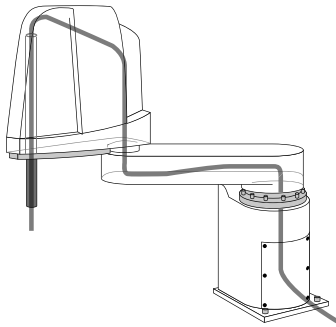

Internal wiring/piping set for hand

This set consists of hand input cables and hoses that can be routed through the spindle until the end of the arm 2.

A bracket to fix the set on the arm 2 is included. The set can be used with an optional solenoid valve.

Specifications	1F-HS304S-01	1F-HS408S-01	1F-HS604S-01
Robots	RH-1FRHR/RH-3FRH	RH-6FRH	RH-12FRH/20FRH
Stroke	mm —	200	350
Length from the shaft end	mm 300	300	400
Attachment	4 air hoses (Ø 3), 8 hand input cables (0.2 mm ²) 2 power cables (0.3 mm ²)	4 air hoses (Ø 4), 8 hand input cables (0.2 mm ²) 2 power cables (0.3 mm ²)	4 air hoses (Ø 6), 8 hand input cables (0.2 mm ²) 2 power cables (0.3 mm ²)
Remarks	Both ends are free. Eight reducers (Ø 3 to Ø 4) are attached. The robot arm side is connector (HC1, HC2), and one side is free.	Both ends are free. The robot arm side is connector (HC1, HC2), and one side is free.	Both ends are free. The robot arm side is connector (HC1, HC2), and one side is free.
Weight	kg 0.4		
Order information	Art. no. 250468	250469	254396

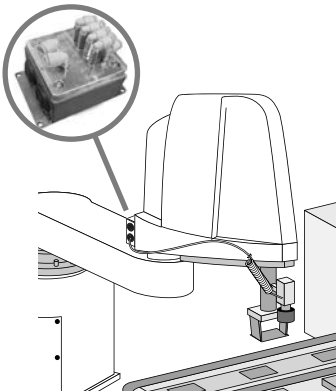

External wiring/piping box

With this option hand output and input cables and pneumatic hoses can be routed from the back of arm 2 to the spindle end outside the robot casing. Connections for connecting the external hoses and brackets for attaching the cables and hoses are

included. The option can also be used for oil mist and clean room models. A bracket to fix the set on the arm 2 is included. The set can be used with an optional solenoid valve.

Specifications	1F-UT-BOX	1F-UT-BOX-01
Robots	RH-3FRH/6FRH	RH-12FRH/20FRH
Attachment	Eight air hoses (connect to solenoid valve) Installation screws (conical spring washer, plain washer)	
Weight	kg 0.5	
Order information	Art. no. 251104	254398

Pulled out from robot arm

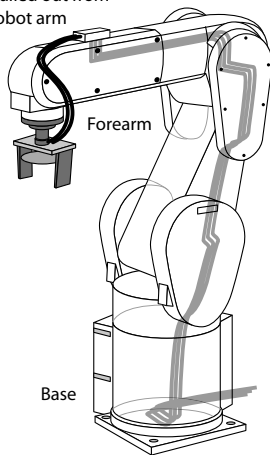

Forearm external wiring set/base external wiring set

With these options the hand input signal cables and the communication cables etc. can be led out of the bottom of the forearm and from the side of the base.

Use the recommended pairing in the table to led out the same cables on the arm side and at the base.

Specifications	1F-HB01S-01	1F-HA01S-01
Robots	RV-4FRL/7FR/7FRL/7FRL/13FR/13FRL/20FR	
Part name	Forearm external wiring set	Base external wiring set
Hand input signal cable	8	—
Vision sensor camera cable	1	1
Additional cable	4	4
Recommended pairing	●	●
Order information	Art. no. 257936	257935

Solenoid valve sets



Solenoid gripper control valve sets

This option is used to control the gripper tool installed on the robot arm. The valve set comes with all the components required for installation, including the branch manifold, couplings and dampers.

The valves are fitted with plug-in control cables for quick and easy wiring. The solenoid valve sets are for use with oil-free compressed air.

Specifications	1A-VDO□E-RP				1F-VV0□E-01		1E-VDO□E		
	1	2	3	4	1	2	1	2	
No. of valves	1	2	3	4	1	2	1		
Range of use (robot type)	RP-1/3/5ADH				RH-1FHR		RV-2FR(B)/RV-2FRL(B)		
Valve function	Double solenoid				Vacuum valve		Double solenoid		
Operating method	Internal pilot method				Two-stage ejector		Internal pilot method		
Effective sectional area (CV value)	1.5 mm				1.5 mm		1.5 mm		
Operating pressure range	2–7 bar				3–6 bar		2–7 bar		
Maximum pressure	10 bar				10 bar		10 bar		
Response time	<12 ms at 24 V DC				<2.5 ms at 24 V DC		<12 ms at 24 V DC		
Max. operating frequency	5 Hz				5 Hz		5 Hz		
Ambient temperature	-10–50 °C				-5–50 °C		-10–50 °C		
Coil rated voltage	24 V DC ±10 %				24 V DC ±10 %		24 V DC ±10 %		
Order information	Art. no.	129780	129781	129792	129793	277712	277713	47397	47398

Specifications	1S-VDO□E-05	1F-VDO□E-01				1S-VDO□E-01				1F-VDO□E-02				1F-VDO□E-03				
	4	1	2	3	4	1	2	3	4	1	2	3	4	1	2	3	4	
No. of valves	4	1	2	3	4	1	2	3	4	1	2	3	4	1	2	3	4	
Range of use (see page)	RH-3FRHR	RH-1FRHR, RH-3FRH, RH-6FRH				RH-12/RH-20FRH				RV-4FRL, RV-7FR, RV-7FRL				RV-13FR, RV-20FR				
Valve function	Double solenoid	Double solenoid				Double solenoid				Double solenoid				Double solenoid				
Operating method	Internal pilot method	Internal pilot method				Internal pilot method				Internal pilot method				Internal pilot method				
Effective sectional area (CV value)	0.64 mm	0.64 mm				0.64 mm				0.64 mm				0.64 mm				
Operating pressure range	1–7 bar	1–7 bar				1–7 bar				1–7 bar				1–7 bar				
Maximum pressure	10 bar	10 bar				10 bar				10 bar				10 bar				
Response time	<22 ms at 5 bar	<22 ms at 5 bar				<22 ms at 5 bar				<22 ms at 5 bar				<22 ms at 5 bar				
Max. operating frequency	5 Hz	5 Hz				5 Hz				5 Hz				5 Hz				
Ambient temperature	-10–50 °C	-10–50 °C				-10–50 °C				-10–50 °C				-10–50 °C				
Coil rated voltage	24 V DC ±10 %	24 V DC ±10 %				24 V DC ±10 %				24 V DC ±10 %				24 V DC ±10 %				
Order information	Art. no.	238375	250470	250471	250472	250473	153057	153058	153059	153062	255281	255282	255283	255284	268829	268830	268831	268832

Bellows



Bellows

By adding the bellows to the Z axis, the IP protection can be increased to IP65 for the SCARA robots RH-1FRHR, RH-6FRH, RH-12FRH, and RH-20FRH.

Bellow type	Robot type	Z-Axis length	Art. no.
1F-JS-21	RH-1FRHR	150 mm	277714
1F-JS-01	RH-6FRH	200 mm	251456
1F-JS-02	RH-6FRH	340 mm	251457
1F-JS-05	RH-12FRH	350 mm	255689
1F-JS-06	RH-12FRH	450 mm	255690
1F-JS-09	RH-20FRH	350 mm	255639
1F-JS-10	RH-20FRH	450 mm	255694

Expansion option cards

Interface boards for robot controllers



I/O interface

You can increase the number of I/Os to a maximum of 64 by adding 2D-TZ378 interface modules.

By adding 2A-RZ371 slot-in cards you can increase the number of remote I/Os to 256 (depends on the controller model).

Specifications	2A-RZ371	2D-TZ378
Application	Interface for additional inputs/outputs	
Type	Decentralized I/O box with 32 inputs and 32 outputs	Slot-in card with 32 inputs and 32 outputs
Range of use	All MELFA robots except R series	
Rated load voltage	Inputs: 12 V/24 V; outputs: 12 V/24 V, max. 0.1 A/per output	
Max. no. of usable I/O boxes	7	2
Order information	Art. no. 124658	218862

For I/O connection cables see page 45

Pneumatic hand interface

The 2A-RZ375 interface card is used to operate the robot's pneumatic gripper. It controls the solenoid valve set (see page 41).

Specifications	2A-RZ375
Application	Interface for pneumatic hand (pneumatic valves)
Range of use	All MELFA robots except FR series and F series
Connections	Up to 4 pneumatic valves
Order information	Art. no. 124657

CC-Link interface

The 2D-TZ576 interface makes it possible to integrate the CR□-D robot controller in a CC-Link network.

The CC-Link interface is a high-speed bit (for I/Os) and word (for data registers) network card.

Specifications	2D-TZ576
Application	CC-Link interface
Range of use	All MELFA robots except R series
Communications cable	Shielded 3-core twisted cable
Max. number of I/O points and data registers	126 I/Os/16 data register
Refresh rate	7.2 ms
Communications distances	100 m at 10 Mbps, 150 m at 5 Mbps, 250 m at 2.5 Mbps, 600 m at 0.62 Mbps, 1500 m at 0.15 Mbps
Order information	Art. no. 219063

Profibus interface

These interface cards make it possible to integrate the robot controller in a Profibus network.

Specifications	2D-TZ577
Application	Profibus DP interface
Range of use	All MELFA robots except Q series
Communications cable	Twisted pair cable
Communications distances	1200 m at 9.6/19.2/93.75 Kbps, 1000 m at 187.5 Kbps, 400 m at 500 Kbps, 200 m at 1500 Kbps
Max. no. of communications words	122
Order information	Art. no. 218861

Profinet I/O / EtherNet/IP / CC-Link IE Field interface

These interface cards make it possible to integrate the robot controller in a Profinet I/O, in a Ethernet/IP or in a CC-Link IE Field network.

Specifications	2D-TZ535-PN-SET	2D-TZ535-EIP-SET	2F-DQ535-CCIEF-SET
Application	Profinet I/O	EtherNet/IP	CC-Link IE Field
Range of use	All MELFA robots except R series		
Communications cable	Industrial Ethernet twisted pair cable		
Transmission speed	100 Mbit/s	1 Gbit/s	
Number of I/O data	Max. 256 bytes send and max. 256 bytes receive		
Order information	Art. no. 269546	282409	324560

■ Gripper signal cables



Connection cables

A variety of different cables are available for connecting the control and status monitoring signals of the gripper tools.

When the pneumatic gripper is used you need to monitor the position of the gripper.

You should thus always connect a gripper signal input cable when you use the pneumatic gripper. One end of the cable set is fitted with a plug for the gripper's sensor signals. The other end is without connectors and can be wired as required for your system.

Specifications	1A-GR200-RP	1E-GR355	1F-GR355-02	1F-GR605-01	1S-GR355-02
Type	Hand signal output cable				
Range of use (robot type)	RP-1/3/5ADH	RV-2FR(B)/RV-2FRL(B)	RV-4FRL, RV-7FR/RV-7FRL/7FRL, RV-13FR/13FRL, RV-20FR	RH-1FRHR, RH-3FRH/RH-6FRH/RH-12FRH/RH-20FRH	RH-3FRHR
Design	Single sided with connector	Single sided with connector	Single sided with connector	Single sided with connector	Single sided with connector
Application	Custom-made magnetic valve set	Custom-made magnetic valve set	Custom-made magnetic valve set	Custom-made magnetic valve set	Custom-made magnetic valve set
Length	mm 2000	350	500	1050	450
Order information	Art. no. 129778	47391	255285	250467	166272

Specifications	1A-HC200-RP	1F-HC35C-01	1F-HC35C-02	1F-HC35S-02	1S-HC00S-01	1S-HC30C-11
Type	Hand signal input cable					
Range of use (robot type)	RP-1/3/5ADH	RH-1FRHR, RH-3FRH, RH-6FRH	RH-12FRH/RH-20FRH	RV-4FRL, RV-7FR, RV-7FRL/7FRL, RV-13FR/13FRL, RV-20FR	RH-3FRHR	RV-2FR(B)/RV-2FRL(B)
Design	Single sided with connector	Single sided with connector	Single sided with connector	Single sided with connector	Single sided with connector	Single sided with connector
Application	Monitoring of the gripper condition	Monitoring of the gripper condition	Monitoring of the gripper condition	Monitoring of the gripper condition	Monitoring of the gripper condition	Monitoring of the gripper condition
No. of cores	10	12	12	10	6	11
Length	mm 2000	1650	1800	1000	1210	300
Order information	Art. no. 129779	250474	254395	255286	238376	257063

■ Connectors and valve signal cables

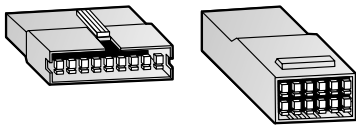

The connection to your system

Choose additional components to configure the optimal interface between the robot system and your application. The wide range of options makes it possible to configure the robot precisely for the individual requirements of your application.

The connectors listed in the following table can be used for making your own cables for the gripper input and output signals (see also the table above).

Specifications	R-SMR-09V-B	R-SMR-10V-N	S-series Hand OUTPUT	S-series Hand INPUT	RV-F / RV-FR Connector Set	RH-FH / RH-FRH Connector Set
Type	Gripper output connector	Gripper output connector	Hand signal output connector	Hand signal input connector	Connector set for OP1/2/3/4 & GR1/2 signals and LAN	Connector set for HC1/2 & GR1/2 signals
Range of use (robot type)	RP-1/3/5ADH	RP-1/3/5ADH	All MELFA robots except RP-ADH and RV-FR series	All MELFA robots except RP-ADH and RV-FR series	All MELFA RV-FR robots	All MELFA RH-FRH robots
Design	Black, 9 pins	White, 10 pins	8 pins	6 pins	Complete set	Complete set
Shipping contents	Plug and contacts	Plug and contacts	Plug and contacts	Plug and contacts	Plug and contacts	Plug and contacts
Order information	Art. no. 132112	132113	164814	164815	268039	273182

Tubes, extension cables

Hand curl tube

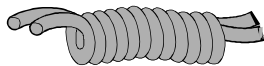

Replacement gripper hoses

These spiral hoses are for use with the pneumatic gripper. They are also suitable for use with clean room robots.

Specifications	1E-ST0404C	1E-ST0408C-300	1N-ST0608C-01	1S-ST0304S
Type	Spiral hose			
Range of use (robot type)	RV-2FR(B)/2FRL(B), RV-4FRL, RV-7FR/7FRL/7FRL	RH-1FRHR, RH-3FRH/6FRH	RH-12FRH/20FRH, RV-13FR/20FR	RH-3FRHR
Application	For double pneumatic gripper	For quadruple pneumatic gripper	For quadruple pneumatic gripper	For double pneumatic gripper
Dimensions	mm 4xØ 4	8xØ 4	8xØ 6	4xØ 3
Order information	Art. no. 47389	270236	269556	238377

Machine cables for robots and controllers



Replacement cables for power and signal connections

These machine cables make it possible to decrease/increase the distance between the controller and the robot arm. Versions are available for either flexible and fixed routing of the cables between the controller and the robot arm.

Use the flexible versions for installation of the cables in drag chains and similar configurations. These cables replace the standard cables supplied with the robot.

Specifications	1F-02UCBL-41	1F-10UCBL-41	1F-15UCBL-41	1F-20UCBL-41
Type	Replacement cable for a fixed installation			
Range of use (robot type)	RV-2FR, RV-2FRL, RV-4FRL, RV-7FR/7FRL/7FRL, RV-13FR/13FRL, RV-20FR, RH-3FRHR, RH-6FRH, RH-12FRH, RH-20FRH			
Minimum bending radius	More than 150 mm			
Protection rating	Oil-proof specification sheath			
Length	m 2	10	15	20
Order information	Art. no. 325730	313106	313107	327863

Specifications	1F-10LUCBL-41	1F-15LUCBL-41	1F-20LUCBL-41	1A-05LCBL-1
Type	Replacement cable for a flexible installation in a drag chain			
Range of use (robot type)	RV-2FR, RV-2FRL, RV-4FRL, RV-7FR/7FRL/7FRL, RV-13FR/13FRL, RV-20FR, RH-3FRHR, RH-6FRH, RH-12FRH, RH-20FRH			RP-ADH
Minimum bending radius	More than 100 mm			
Cable bear isovolumetric ration	≤50 %			
Max. movement speed	2000 mm/s			
Guidance of life count	7.5 million times			
Protection rating	Oil-proof specification sheath			
Length	m 10	15	20	5
Order information	Art. no. 157582	313109	327864	167304

■ Connection cables for PCs and inputs/outputs



Connection cables, connectors

The RV-CAB□ cable is for establishing an RS232C serial connection between the robot controller and a personal computer, whereby the MR-J3USBCBL3M can be used for USB connection.

The I/O connection cable is for connecting peripherals to the parallel I/O interface.

One end of the cable is fitted with a connector for the controller's parallel I/O port. The other end is supplied without a connector so that you can connect the appropriate connectors for your equipment.

Specifications	MR-J3USBCBL3M	2A-CBL05	2A-CBL15	2D-CBL05	2D-CBL15	
Type	USB Cable					
Application	USB connection PC-controller	I/O cable for 2A-RZ371		I/O cable for 2D-TZ378		
Range of use	FR series	All MELFA robots except R series				
Design	Mini USB	Plug on one side				
Length	m	3	5	5	15	
Order information	Art. no.	160229	47387	59947	218857	218858

■ Controller protection box (IP54)



The controller protection box for the control unit CR800 prevents the penetration of oil mist or other influences from the operating environment.

The front of the housing is equipped with a mode switch and a connector for the teaching box.

Specifications	CR800-MB
Type	Controller protection box
Application	Controller CR800
Dimensions (WxHxD)	mm 495x250x725
Order information	Art. no. 313062

■ Buffer batteries



Batteries

The backup batteries are used to maintain the encoder and memory power supply. One battery supplies the control unit and up to five batteries are installed in the robot arm.

Specifications	RP-ADH series	RH-FRH series	RV-FR series	Art. no.
MR-BAT6V1	Number	4	4	248692
AGBAT	Number	3	—	4077
Q6BAT	Number	1	—	130376
Battery-Set RH-FR/RV-FR	for RH-FR series and RV-FR series consists of 4 pcs. MR-BAT6V1			327911

Configurations options

Options overview for all robots

Option	Marking	RV-2FR(B)/ RV-2FRL(B)	RV-4FRLM	RV-7FRM/ RV-7FRLM	RV-13FRM/ RV-13FRLM/ RV-20FRM	RH-3FRH	RH-6FRH	RH-12FRH/ RH-20FRH	RH-1FRHR	RH-3FRHR	RP- 1/3/SADH	Art. no.	See Page
Teaching Box	R32TB	●	●	●	●	●	●	●	●	●	●	214968	38
Teaching Box	R56TB	●	●	●	●	●	●	●	●	●	●	218854	38
Force sensor	4F-FS002H-W200	●	●	●	●	●	●	●	●	●	●	313064	39
	4F-FS002H-W1000	●	●	●	●	●	●	●	●	●	●	313105	39
MELFA SafePlus	4F-SF002-01	●	●	●	●	●	●	●	●	●	●	313061	39
MELFA Smart Plus Card	2F-DQ510	●	●	●	●	●	●	●	●	●	●	325728	39
	2F-DQ511	●	●	●	●	●	●	●	●	●	●	325729	39
Single valve set	1A-VD01E-RP										●	129780	41
Double valve set	1A-VD02E-RP										●	129781	41
Triple valve set	1A-VD03E-RP										●	129792	41
Quadruple valve set	1A-VD04E-RP										●	129793	41
	1S-VD04E-05									●		238375	41
Single valve set	1E-VD01E	●										47397	41
Double valve set	1E-VD02E	●										47398	41
Single valve set	1F-VD01E-01					●	●		●			250470	41
Double valve set	1F-VD02E-01					●	●		●			250471	41
Triple valve set	1F-VD03E-01					●	●		●			250472	41
Quadruple valve set	1F-VD04E-01					●	●		●			250473	41
Single valve set	1F-VD01E-02		●	●								255281	41
Double valve set	1F-VD02E-02		●	●								255282	41
Triple valve set	1F-VD03E-02		●	●								255283	41
Quadruple valve set	1F-VD04E-02		●	●								255284	41
Single valve set	1F-VD01E-03				●							268829	41
Double valve set	1F-VD02E-03				●							268830	41
Quadruple valve set	1S-VD04E-01							●				153062	41
Single vacuum valve set	1F-VV01E-01								●			277712	41
Double vacuum valve set	1F-VV02E-01								●			277713	41
Bellows	1F-JS-21								●			277714	41
	1F-JS-01						●					251456	41
	1F-JS-02						●					251457	41
	1F-JS-05							●				255689	41
	1F-JS-06							●				255690	41
	1F-JS-09							●				255639	41
	1F-JS-10							●				255694	41
CC-Link interface ①	2D-TZ576	●	●	●	●	●	●	●	●	●	●	219063	42
CC-Link IE Field interface	2F-DQ535-CCIEF-SET	●	●	●	●	●	●	●	●	●	●	324560	42
Profibus interface ①	2D-TZ577	●	●	●	●	●	●	●	●	●	●	218861	42
Profinet interface	2D-TZ535-PN-SET	●	●	●	●	●	●	●	●	●	●	269546	42
Ethernet/IP interface	2D-TZ535-EIP-SET	●	●	●	●	●	●	●	●	●	●	282409	42
I/O interface ①	2D-TZ378	●	●	●	●	●	●	●	●	●	●	218862	42
	2A-RZ371	●	●	●	●	●	●	●	●	●	●	124658	42
Pneumatic hand interface	2A-RZ375									●	●	124657	42
Hand signal output cable	1A-GR200-RP										●	129778	43
	1E-GR355	●										47391	43
	1F-GR355-02		●	●	●							255285	43
	1F-GR605-01					●	●	●	●			250467	43
	1S-GR355-02									●		166272	43
Hand signal input cable	1A-HC200-RP										●	129779	43
	1F-HC35C-01					●	●		●			250474	43
	1F-HC35C-02							●				254395	43
	1F-HC355-02		●	●	●							255286	43
	1S-HC005-01									●		238376	43
1S-HC30C-11	●										257063	43	
Gripper output connector	R-SMR-09V-B										●	132112	43
Gripper input connector	R-SMR-10V-N										●	132113	43
Hand signal output connector	S-series Hand OUTPUT		●	●	●	●	●			●		164814	43
Hand signal input connector	S-series Hand INPUT		●	●	●	●	●			●		164815	43

3 Accessories

Options overview for all robots

Option	Marking	RV-2FR(B)/ RV-2FRL(B)	RV-4FRLM	RV-7FRM/ RV-7FRLM RV-7FRLLM	RV-13FRM/ RV-13FRLM/ RV-20FRM	RH-3FRH	RH-6FRH	RH-12FRH/ RH-20FRH	RH-1FRHR	RH-3FRHR	RP- 1/3/SADH	Art. no.	See Page
Connector sets	RH-FRH Hand connector set					●	●	●	●	●		273182	43
	RV-F/RV-FR connector set		●	●	●							268039	43
Hand curl tube ^①	1E-ST0404C	●	●	●								47389	44
	1E-ST0408C-300					●	●		●			270236	44
	1S-ST0304S									●		238377	44
	1N-ST0608C-01				●			●				269556	44
Internal wiring and piping set	1F-HS304S-01					●			●			250468	40
	1F-HS408S-01						●					250469	40
	1F-HS604S-01							●				254396	40
External wiring/piping box	1F-UT-BOX					●	●					251104	40
	1F-UT-BOX-01							●				254398	40
Forearm external wiring set	1F-HB01S-01		●	●	●							257936	40
Base external wiring set	1F-HA01S-01		●	●	●							257935	40
Extension cable for fixed installation	1F-02UCBL-41		●	●	●		●	●		●		325730	44
	1F-10UCBL-41		●	●	●		●	●		●		313106	44
	1F-15UCBL-41		●	●	●		●	●		●		313107	44
	1F-20UCBL-41		●	●	●		●	●		●		327863	44
Extension cable for flexible installation in a drag chain	1A-05LCBL-1										●	167304	44
	1F-10LUCBL-41		●	●	●		●	●		●		157582	44
	1F-15LUCBL-41		●	●	●		●	●		●		313109	44
	1F-20LUCBL-41		●	●	●		●	●		●		327864	44
PC connection cable USB	MR-J3USBCBL3M	●	●	●	●	●	●	●	●		160229	45	
Connection cable for I/O interface ^①	2A-CBL05	●	●	●	●	●	●	●	●	●	●	47387	45
	2A-CBL15	●	●	●	●	●	●	●	●	●	●	59947	45
	2D-CBL05	●	●	●	●	●	●	●	●	●	●	218857	45
	2D-CBL15	●	●	●	●	●	●	●	●	●	●	218858	45
Controller protection box (IP54)	CR800-MB	●	●	●	●	●	●	●			313062	45	
Wall mount	R32TB wall mount	●	●	●	●	●	●	●	●	●	274317	38	
Wall mount	R56TB wall mount	●	●	●	●	●	●	●	●	●	204294	38	

① except Q series

MELFA-BASIC programming

Easy-to-Learn MELFA-BASIC Programming language

Mitsubishi Electric robots are controlled with programs written in the powerful MELFA BASIC programming language. In addition to the familiar standard BASIC instructions and constructs like FOR ... NEXT and GOTO, MELFA BASIC also has some extensions required for robots, including additional data types, instructions for movement and gripper control and I/O instructions. The familiarity of standard BASIC makes it easy for beginners to get started with robot programming.

Despite its simplicity and short learning curve, MELFA BASIC is a powerful language that can be used to create very complex robot programs. MELFA BASIC VI allows structured programming with functions and re-use code and ready-made libraries are additionally improving the reusability and readability.

Programming

Robot programs are written with the MELFA BASIC instructions with the help of a PC and the teaching box. The positions

are defined with the teaching box and the actual program is written on the PC.

Programs are written using the RTToolbox3 programming and project managing software for industrial robots. You can find more information about the programming software on the following pages..

4

Programming language

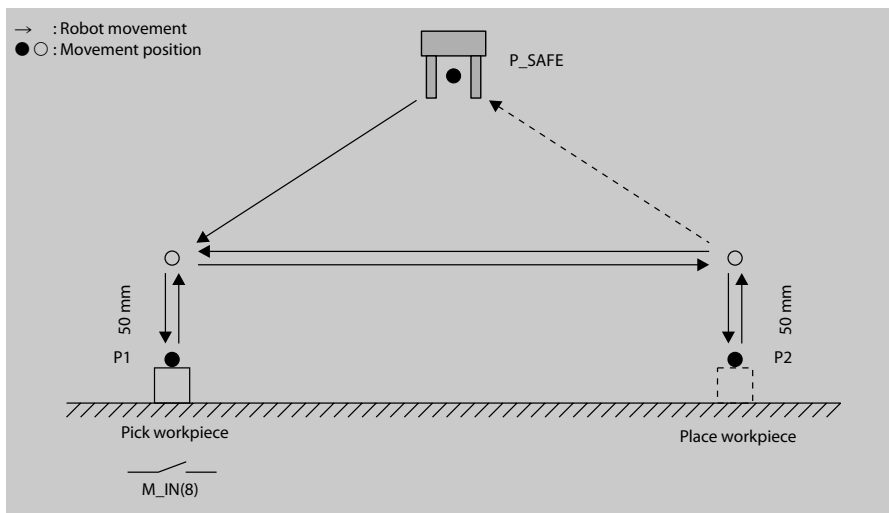

Sample program

The sample program below is for a pick-and-place operation. The input signal M_IN(8) tells the program that there is a workpiece in position P1. When a workpiece is present the input signal is set to 1 and the pick-and-place operation is performed. The workpiece is picked up from position P1 and deposited in position P2. If no workpiece is present the robot remains in the retracted position P_SAFE.

Pick-and-Place Program

1	MVS P_SAFE	Move to safe position
2	Wait M_IN(8) = 1	Wait until input bit 8 is set
3	HOPEN 1	Open gripper 1
4	*PickPlace	Jump-Destination "PickPlace"
5	MVS Pick, -50	Move longitudinally to a position 50 mm from "Pick" relative to the tool Z-direction
6	MVS Pick	Move to position "Pick"
7	HCLOSE 1	Close gripper 1
8	DLY 0.2	Wait for 0.2 s to ensure proper closing of gripper
9	MVS Pick, -50	Move longitudinally to a position 50 mm from "Pick" relative to the tool Z-direction
10	MVS Place, -50	Move longitudinally to a position 50 mm from "Place" relative to the tool Z-direction
11	MVS Place	Move to position "Place"
12	HOPEN 1	Open gripper 1 and deposit workpiece
13	DLY 0.2	Wait for 0.2 s to ensure proper opening of gripper
14	MVS Place, -50	Move longitudinally to a position 50 mm from "Place" relative to the tool Z-direction
15	IF M_IN(8) = 1 THEN GOTO *PickPlace	If another workpiece is present repeat the pick-and-place operation
16	MVS P_SAFE	If no workpiece is present return to safe position and end program
17	END	Program end

RT Toolbox3

RT Toolbox3 is a software for program creation and total engineering support. This PC software supports everything from system startup to debugging, simulation, maintenance and operation. This includes programming and editing, operational checking before robots are installed, measuring process tact time, debugging

during robot startup, monitoring robot operation after startup, and trouble shooting.

- Compatible with Windows® XP, Windows® Vista, Windows® 7, Windows® 8 and Windows® 10.

- Support for all processes, from programming and startup to maintenance
- Enhanced simulation functions
- Advanced maintenance functions
- Extended documentation function

Enhanced RT Toolbox3 visual functions

- Set parameters can be displayed visually to prevent setting errors.
- Display of teaching positions and trajectories of end points.
- Hands can be created and then attached to the robot.
- 3D polygonal models can be imported into the program.(Applicable 3D data file formats: STL, OBJ)

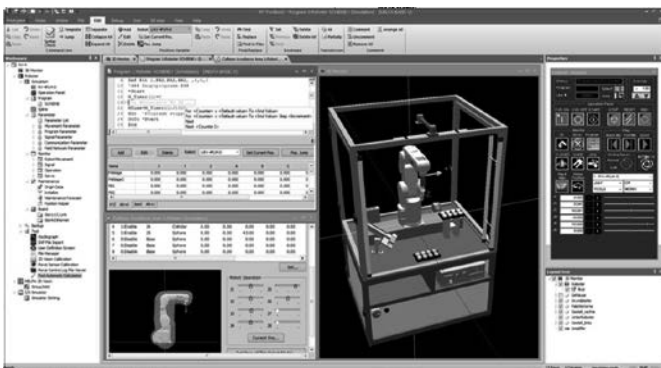

Linked to iQ Works2

- Integrated Software Suite
Consists of GX Works3, MT Works2, GT Works3, RT Toolbox3 and FR Configurator2, which are programming software for each respective product
- System management software
MELSOFT Navigator is the central system configuration incorporating an easy-to-use, graphical user interface with additional project-sharing features such as system labels and parameters.

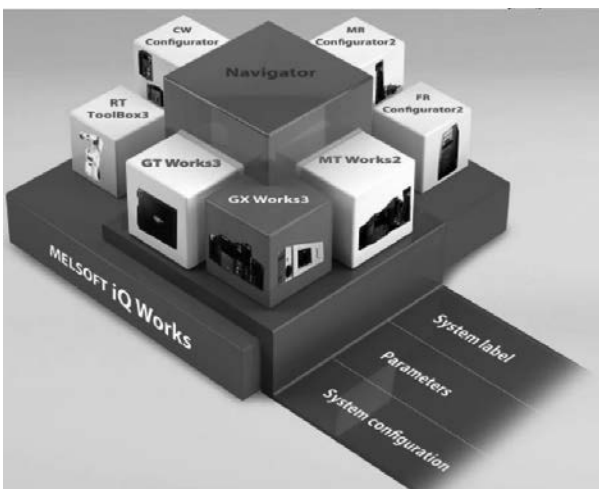

Program editing and debugging functions

Creation of programs in MELFA-BASIC IV/V/VI and the Movemaster languages.* Improvement of work operations by a multi-window format and the various editing functions. This is helpful for use in checking operations such as the execution of program steps, setting of breakpoint settings, and other tasks.

* MELFA-BASIC is a programming language that further expands upon and develops the commands needed for robot control. In MELFA-BASIC, the expansion of the command as well as parallel processing or structuring that were difficult to realize in BASIC language can make it possible to operate MELFA easily.

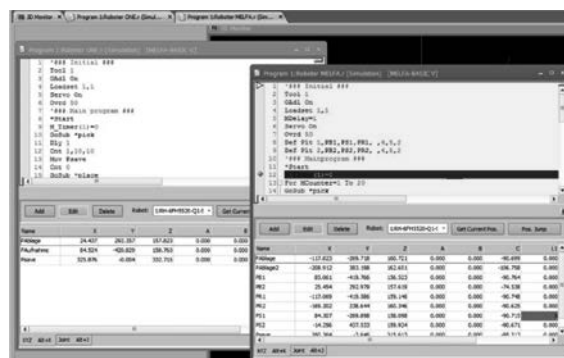

Simulation functions

Offline robot motion and tact time check for designated parts of a program.

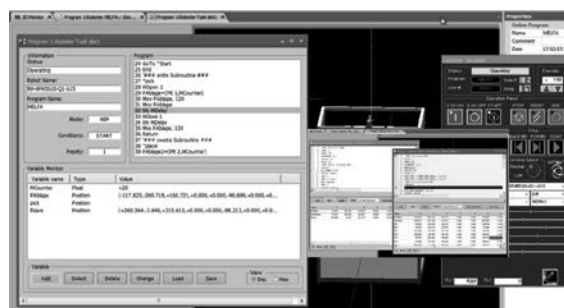

3D viewer

Graphical representation of a work along with the dimensions, color and other specified details of the work area to be gripped.

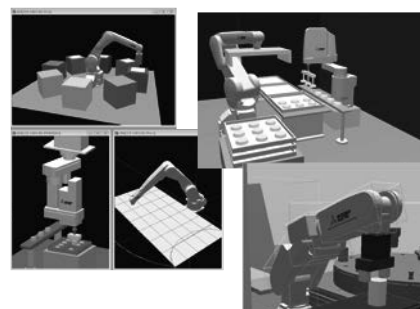

Software

Monitor functions

This is used to monitor program execution status and variables, input signals, etc.)

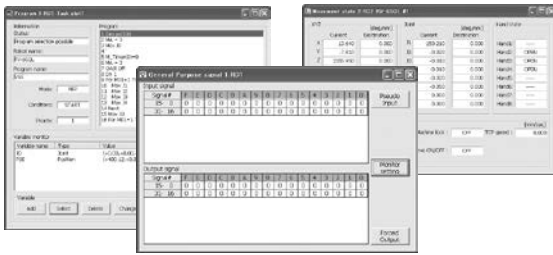

Maintenance functions

These functions include maintenance forecast, position recovery support, parameter management, etc.

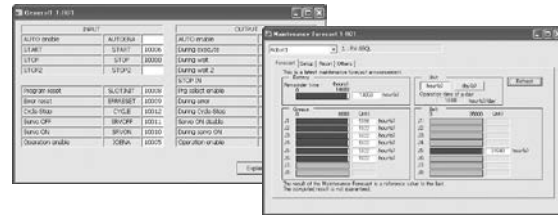

RT Toolbox3 Pro

A 3D robot simulator offers powerful support for system design and preliminary layout.

RT Toolbox3 Pro offers an add-in tool^① for SolidWorks^② used for robot simulation in production systems on PC's converting processing paths of workpieces into robot position data. Adding RT Toolbox3 pro into the SolidWorks platform adds to and expands on the robot simulation functions.

- Loading of part data from peripheral created in SolidWorks® devices and rearrangement
- Installation of hands by CAD files
- Handling of work pieces
- Creating operation data from 3D CAD source data

- Offline teaching in 3D CAD surrounding
- Creation of robot programs (template) Workflow processes can be created using a combination of the offline teaching and CAD link functions and then converted into robot programs. (MELFA-BASIC IV, V, VI format)
- Simulation of robot operations
- Display of the robot movement path in the application/the workspace
- Interference checks between the robot and peripheral devices
- Saving simulated movements to video files (AVI format)

- Measurement of cycle times
- Robot program debugging functions
- Jog function – teaching the robot
- Installation of a travelling axis to verify the operation of the system equipped with this.
- Calibration of point sequence data of CAD coordinates and robot coordinate data

^① An add-in tool is a software program that adds certain functions to application software packages.

^② SolidWorks® is a registered trademark of SolidWorks Corp, (USA).

Automatic robot program creation function

The teaching position data and robot operation programs necessary for operating robots can be generated automatically by simple loading of 3D CAD data^③ for the applicable works into SolidWorks® and then setting of processing conditions and areas using RT Toolbox3 Pro.

^③ Formats that can be loaded into SolidWorks®

- | | | |
|------------------------|---------------------------|------------------------------------|
| • IGES | • PAR (Solid Edge TM) | • Mechanical Desktop |
| • STEP | • IPT (Autodesk Inventor) | • CADKEYR |
| • ParasolidR | • DWG | • Viewpoint |
| • SAT (ACISR) | • DXFTM | • RealityWave |
| • Pro/ENGINEERR | • STL | • HOOPS |
| • CGR (CATIARgraphics) | • VRML | • HCG (Highly compressed graphics) |
| • Unigraphics | • VDA-FS | |

Note: Check the SolidWorks website and other published documents for the latest specifications.

Example screens for RT Toolbox3 Pro

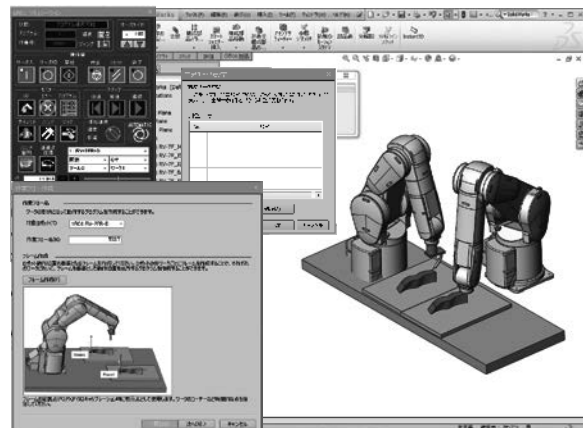

A**Accessories**

Batteries	45
Bellows	41
Connection cables for PCs and inputs/outputs, connectors	45
Controller protection box	45
Force sensor	39
Gripper signal cables	43
Hand curl tube	44
Interface boards	42
Machine cables for robots and controllers	44
MELFA SafePlus	39
MELFA Smart Plus Card	39
Solenoid valve sets	41
Teaching box	38
Valve signal cables and connectors	43
Wiring	40

Articulated arm robots

RV-2FR(B)/RV-2FRL(B)	15
RV-4FRLM	17
RV-7FRM/7FRLM/7FRLLM	19
RV-13FRM/RV-13FRLM/RV-20FRM	21
RV-35F/RV-50F/RV-70F	23

C

Controller	36
-------------------	----

D**Delta robots**

RD-1F500/RD-1F800/RD-1F1100/RD-1F1300	34
---------------------------------------	----

Dimensions

Controller	37
RH-1FRHR	28
RH-3FRHR	30
RH-FRH	32
RP-1ADH/RP-3ADH/RP-5ADH	26
RV-2FR(L)(B)	16
RV-4FRLM	18
RV-7FRM/7FRLM/7FRLLM	20
RV-13FRM/RV-13FRLM/RV-20FRM	22
RV-35F/RV-50F/RV-70F	24

M**Movement ranges**

RH-1FRHR	28
RH-3FRHR	30
RH-FRH	32
RP-1ADH/RP-3ADH/RP-5ADH	26
RV-2FR(L)(B)	16
RV-4FRLM	18
RV-7FRM/7FRLM/7FRLLM	20
RV-13FRM/RV-13FRLM/RV-20FRM	22
RV-35F/RV-50F/RV-70F	24

O

Options overview for all robots	46
--	----

Overview robots

Horizontal, multiple-joint type (RH/RP)	4
Model designation	6
Vertical, multiple-joint type (RV)	4

S**SCARA robots**

RH-1FRHR	27
RH-3FRHR	29
RH-FRH	31
RP-1ADH/RP-3ADH/RP-5ADH	25

Software

MELFA-BASIC programming	48
RT Toolbox3	49
RT Toolbox3 Pro	50

Special functions

Adaptation to operation	9
CC-Link IE Field Network Basic function	11
Collision avoidance	11
Connection to peripheral devices	10
Coordinated control	11
Full use of installation space	7
GOT terminals	14
Improved accuracy	9
Improved tooling performance	7
Improved user friendliness	8
Intelligent technology	12
iQ Platform	14
MELFA SafePlus features	13
Shortened takt times	7

System configuration	35
-----------------------------	----

Your solution partner

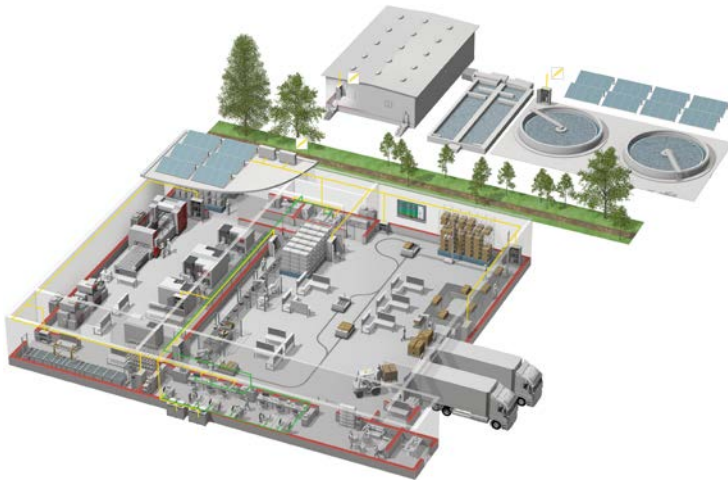

Mitsubishi Electric offers a wide range of automation equipment from PLCs and HMIs to CNC and EDM machines

A name to trust

Since its beginnings in 1870, some 45 companies use the Mitsubishi name, covering a spectrum of finance, commerce and industry.

The Mitsubishi brand name is recognized around the world as a symbol of premium quality.

Mitsubishi Electric Corporation is active in space development, transportation, semi-conductors, energy systems, communications and information processing, audio visual equipment and home electronics, building and energy management and automation systems, and has 237 factories and laboratories worldwide in over 121 countries.

This is why you can rely on Mitsubishi Electric automation solution - because we know first hand about the need for reliable, efficient, easy-to-use automation and control in our own factories.

As one of the world's leading companies with a global turnover of over 4 trillion Yen (over \$40 billion), employing over 130,000 people, Mitsubishi Electric has the resource and the commitment to deliver the ultimate in service and support as well as the best products.



Low voltage: MCCB, MCB, ACB



Medium voltage: VCB, VCC



Power monitoring, energy management



Compact and Modular Controllers



Inverters, Servos and Motors



Visualization: HMIs, Software, MES connectivity



Numerical Control (NC)



Robots: SCARA, Articulated arm



Processing machines: EDM, Lasers, IDS



Air-conditioning, Photovoltaic, EDS

Global Partner. Local Friend.

European Offices

Germany Mitsubishi Electric Europe B.V. Mitsubishi-Electric-Platz 1 D-40882 Ratingen Phone: +49 (0)2102 / 486-0	Czech Rep. Mitsubishi Electric Europe B.V. Pekařská 621/7 CZ-155 00 Praha 5 Phone: +420 255 719 200	France Mitsubishi Electric Europe B.V. 25, Boulevard des Bouvets F-92741 Nanterre Cedex Phone: +33 (0)1 / 55 68 55 68	Ireland Mitsubishi Electric Europe B.V. Westgate Business Park, Ballymount JRL-Dublin 24 Phone: +353 (0)1 4198800	Italy Mitsubishi Electric Europe B.V. Viale Colleoni 7 Palazzo Sario I-20864 Agrate Brianza (MB) Phone: +39 039 / 60 53 1	Netherlands Mitsubishi Electric Europe B.V. Nijverheidsweg 23C NL-3641 RP Mijdrecht Phone: +31 (0) 297 250 350	Poland Mitsubishi Electric Europe B.V. ul. Krakowska 48 PL-32-083 Balice Phone: +48 (0) 12 347 65 00
Russia Mitsubishi Electric (Russia) LLC 2 bld. 1, Letnikovskaya st. RU-115114 Moscow Phone: +7 495 / 721 2070	Spain Mitsubishi Electric Europe B.V. Carretera de Rubi 76-80 Apdo. 420 E-08190 Sant Cugat del Vallés (Barcelona) Phone: +34 (0) 93 / 5653131	Sweden Mitsubishi Electric Europe B.V. (Scandinavia) Hedvig Möllers gata 6 SE-223 55 Lund Phone: +46 (0) 8 625 10 00	Turkey Mitsubishi Electric Turkey Elektrik Ürünleri A.Ş. Serfalli Mahallesi Kale Sokak No:41 TR-34775 Ümraniye-İSTANBUL Phone: +90 (216) 969 25 00	UK Mitsubishi Electric Europe B.V. Travellers Lane UK-Hatfield, Herts. AL10 8XB Phone: +44 (0)1707 / 28 87 80		

Representatives

Austria GEVA Wienert Straße 89 A-2500 Baden Phone: +43 (0)2252 / 85 55 20	Belarus OOO TECHNIKON Prospekt Nezavisimosti 177-9 BY-220125 Minsk Phone: +375 (0)17 / 393 1177	Bosnia and Herzegovina INEA RBT d.o.o. Stegne 11 SI-1000 Ljubljana Phone: +386 (0)1 / 513 8116	Bulgaria AKHNATON 4, Andrei Ljupchev Blvd., PO Box 21 BG-1756 Sofia Phone: +359 (0)2 / 817 6000	Croatia INEA CR Lošnjak 4 a HR-10000 Zagreb Phone: +385 (0)1 / 36 940 -01 / -02 / -03	Czech Republic AutoCont C.S. S.R.O. Kalkova 1833/3 CZ-702 00 Ostrava 2 Phone: +420 595 691 150	Denmark HANS FØLSGAARD A/S Theilgaardsv Torv 1 DK-4600 Kage Phone: +45 4320 8600
Estonia Electrobit OÜ Pärnu mnt. 160i EST-11317, Tallinn Phone: +372 6518 140	Finland UTU Automation Oy Peltoitie 37 FIN-28400 Ulvila Phone: +358 (0)207 / 463 500	Greece UTECO A.B.E.E. 5, Mavrogenous Str. GR-18542 Piraeus Phone: +30 (0)211 / 1206-900	Hungary AutoCont Automatika Kft. (Robot Center) Rokolya utca 1-13 HU-1131 Budapest Phone: +36 (0)1 / 412-0882	Latvia OAK Integrator Products SIA Ritaušmas iela 23 LV-1058 Riga Phone: +371 67842280	Malta ALFA TRADE Ltd. 99, Paola Hill Malta-Paola PLA 1702 Phone: +356 (0)21 / 697 816	Portugal Fonseca SA. R. João Francisco do Casal 87/89 PT-3801-997 Aveiro, Esqueira Phone: +351 (0)234 / 303 900
Romania Sirius Trading & Services Aleea Lacul Morii Nr. 3 RO-060841 Bucuresti, Sector 6 Phone: +40 (0)21 / 430 40 06	Serbia INEA SR d.o.o. Ul. Karadjordjeva 12/217 SER-11300 Smederevo Phone: +386 (0)261 461 54 01	Slovakia SIMAP SK Dolné Pažite 603/97 SK-911 06 Trenčín Phone: +421 (0)32 743 04 72	Slovenia INEA RBT d.o.o. Stegne 11 SI-1000 Ljubljana Phone: +386 (0)1 / 513 8116	Ukraine CSC - AUTOMATION Ltd. 4 B, Yevhena Sverstyuka Str. UA-02002 Kiev Phone: +380 (0)44 / 494 33 44		
Egypt EIM Energy 3 Roxy Square ET-11341 Heliopolis, Cairo Phone: +202 24552559	Israel ILAN & GAVISH Ltd. 24 Shenkar St., Kiryat Ariz IL-49001 Petah-Tikva Phone: +972 (0)3 / 922 18 24	South Africa ADROIT TECHNOLOGIES 20 Waterford Office Park 189 Witkoppen Road ZA-Fourways Phone: +27 (0)11 / 658 8100				

Version check



Art. no. 203684-J

Mitsubishi Electric Europe B.V.

FA - European Business Group
 Mitsubishi-Electric-Platz 1
 D-40882 Ratingen Germany
 Tel.: +49(0)2102-4860 Fax: +49(0)2102-4861120
 info@mitsubishi-automation.com
 https://eu3a.mitsubishielectric.com

Specifications subject to change. All trademarks and copyrights acknowledged.

Printed June 2018