

# MELFA Technical News

BFP-A6079-0217E-\*

January 2018

**Subject:** Precautions of replacement from RH-20SDH to RH-20FRH-D**Applicable to:** RH-20SDH  
RH-20FRH-D

Thank you for your continued support of Mitsubishi industrial MELFA series robots. This Technical News explains in detail the precautions for the replacement of **RH-20SDH** horizontal multiple-joint type robots with **RH-20FRH-D** robots.

## Contents

1. Configurations of the models (Compatible models for replacement) .....	2
2. Specifications comparison .....	2
2. 1 Specifications of the robot arm .....	2
2. 2 Dimensions of the robot arm and diagram of the operating range .....	3
2. 3 Specifications of the controller .....	6
2. 4 Outside dimensions of the controller .....	6
2. 5 Options .....	7
3. Compatibility .....	8
3. 1 Compatibility of the robot arm .....	8
3. 2 Compatibility of the controller .....	8
3. 3 Precautions of the extension function for GOT direct connection .....	8

# Precautions for the replacement of RH-20SDH with RH-20FRH-D.

## 1. Configurations of the models (Compatible model for replacement)

The following shows the compatible models of robot arms and controllers for the replacement of RH-20SDH to RH-20FRH-D.

Model	Controller	➔	Model	Controller
RH-20SDH	CR2DA-751		RH-20FRH-D	CR800-20HD

## 2. Specifications comparison

### 2.1 Specifications of the robot arm

The following table compares the robot arm specifications between old and new models.

Type	Unit	Specifications		
		Old model	New model	
Model		RH-20SDH85xx/M/C	RH-20FH85xx/M/C-D RH-20FH100xx/M/C-D	
Machine class		None: Standard/M: Oil mist Note 4/C: Clean Note 5		
Protection degree		Standard: IP20/M: IP54/C: Class 10 (0.3µm)	Standard: IP20/M: IP65/C: ISO class 3	
Degree of freedom		4		
Installation style		Floor type		
Structure		Horizontal multiple-joint type		
Drive system		AC servo motor		
Position detection method		Absolute encoder		
Maximum load capacity (rating)	kg	20 (5)		
Arm length	No.1 arm	525		
	No.2 arm	325	475	
Maximum reach radius	mm	850	1000	
Operating range	J1	280 (±140)		
	J2	306 (±153)		
	J3 (Z)	xx = 35 : 350 / xx = 45 : 450 (standard) xx = 30 : 300 / xx = 40 : 400 (M specification/C specification)	xx = 35 : 350/xx = 45 : 450	
	J4 (θ)	720 (±360)		
Maximum speed Note 6)	J1	288	280	
	J2	412.5	450	
	J3 (Z)	1200	2400	
	J4 (θ)	1500	1700	
Maximum composite speed Note 1)	mm/sec	11221	11372 13283	
Cycle time Note 2)		0.46	0.30 0.36	
	X-Y composite	mm	±0.025	
Positioning repeatability	J3 (Z)	mm	±0.01	
	J4 (θ)	deg	±0.03	
			±0.005	
Ambient temperature	°C	0 to 40		
Mass	kg	Approx. 47	75 77	
Tolerable amount of inertia (rating)	J4 (θ)	kg, m2	0.2 (0.02)	1.05 (0.065) Note 7)
Tool wiring		Hand: 8 input points/8 output points (forearm), 8 spare wires: AWG#27 (0.2mm <sup>2</sup> )	Hand: 8 input points/8 output points (20 pins total) Serial signal cable for parallel I/O (2-pin + 2-pin power line) LAN × 1<100BASE-TX> (8-pin) Note 3)	
Tool pneumatic piping		Primary: φ6 × 2 Secondary: φ6 × 8		
Machine cable		5m (connector on both ends)		
Paint		Color: Light gray (Reference Munsell color: 0.08GY7.64/0.81)	Color: Light gray (Reference Munsell color: 0.6B7.6/0.2)	

Note 1) The value assumes composition of J1, J2, and J4.

Note 2) Value for a maximum load capacity of 2kg. The cycle time may increase if specific requirements apply such as high work positioning accuracy, or depending on the operating position. (The cycle time is based on back-and-forth movement over a vertical distance of 25mm and horizontal distance of 300mm.)

Note 3) Can also be used as a spare line (0.2sq 4-pair cable) for conventional models.

Note 4) Please contact a Mitsubishi Electric dealer since the environment resistance may not be secured depending on the characteristics of oil you use. Direct jet to the bellows is excluded.

Note 5) Preservation of cleanliness levels depends on conditions of a downstream flow of 0.3m/s in the clean room and internal robot suctioning. φ8-mm couplers (2 pcs.) for suctioning are provided at the back of the base.

Note 6) The value of when MvTune2 (high-speed mode) is applied.

Note 7) For the offset hand, when the distance between the center of a load and the center of J4 axis exceeds 120mm, errors such as an excessive error will occur. In this case, adjust speed, acceleration, and deceleration.

### 2.2 Dimensions of the robot arm and diagram of the operating range

#### 1) Robot arm installation dimensions and mechanical interface

The installation dimensions and mechanical interface have changed. Refer to the following diagrams.

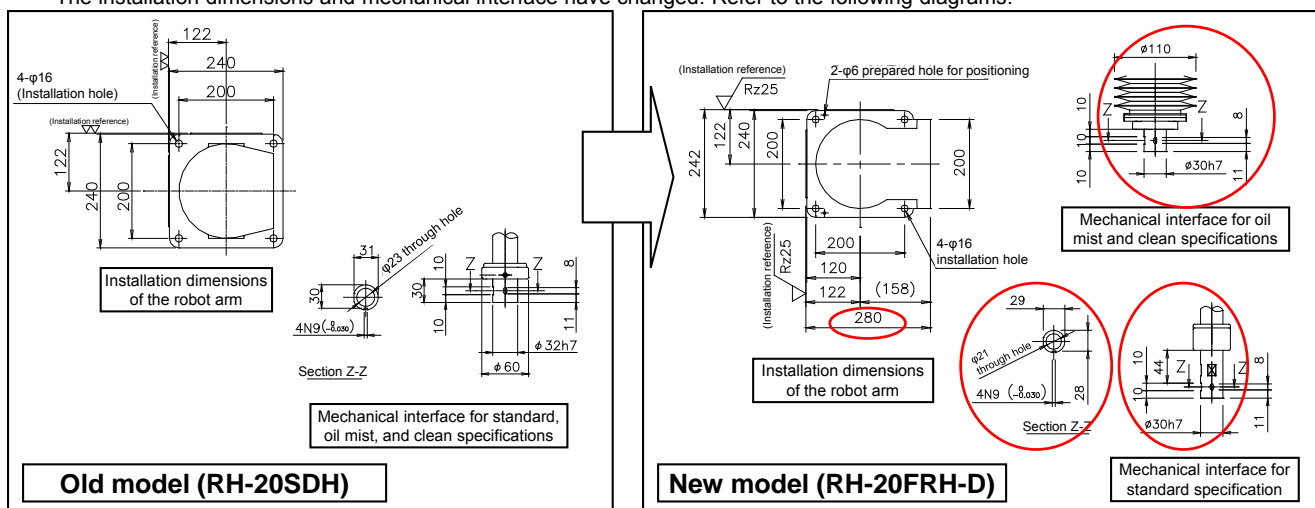

2) Dimensions of the robot arm and diagram of the operating range

For the dimensions of the robot arm and diagram of the operating range, refer to the following.

**Operating range difference**

- RH-20FRH85xx-D:  
(Shaded area with lines upward to the right + shaded area with lines downward to the right)
- RH-20SDH85xx:  
(Shaded area with lines upward to the right)

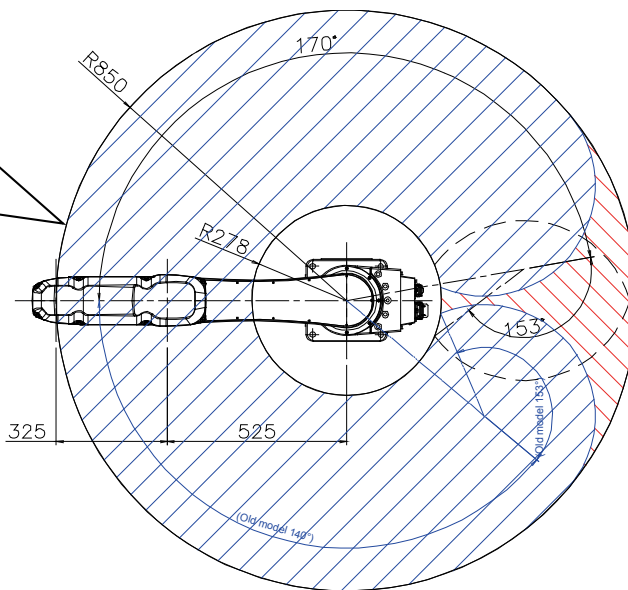

**Operating range difference**

- RH-20FRH100xx-D:  
(Shaded area with lines upward to the right + shaded area with lines downward to the right)
- RH-20SDH100xx:  
(Shaded area with lines upward to the right)

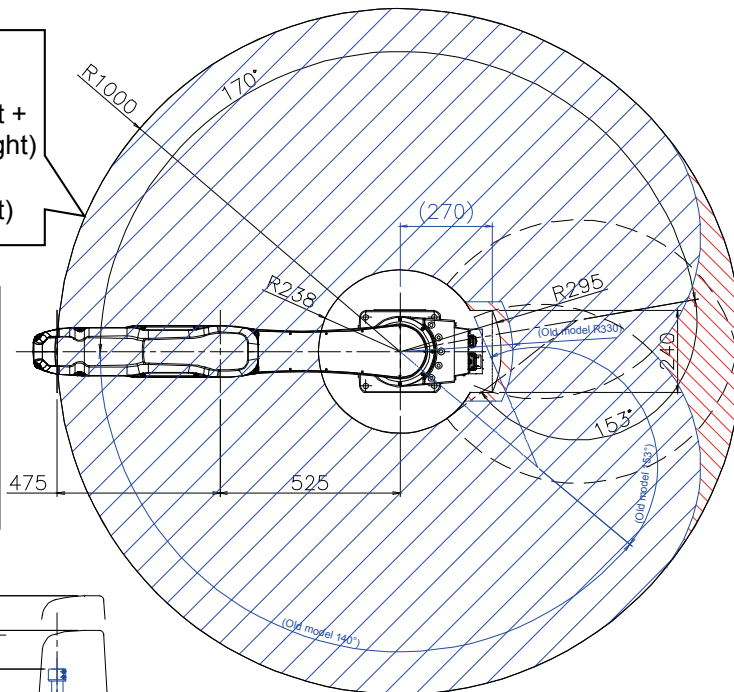

**Overall height difference: 113mm**

- RH-20FRH10045: 1180mm
- RH-20SDH10045: 1067mm

**Overall height difference: 113mm**

- RH-20FRH10035: 1080mm
- RH-20SDH10035: 967mm

RH-20FRH10045-D

RH-20SDH10045

RH-20FRH10035-D

RH-20SDH10035

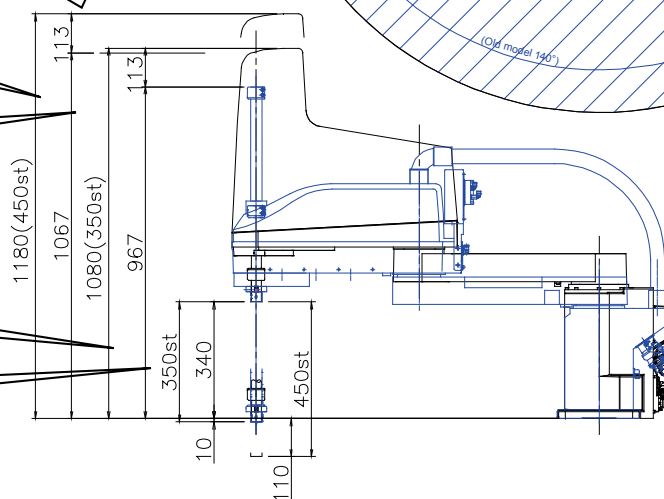

A duct (φ50 (2m)) is installed.

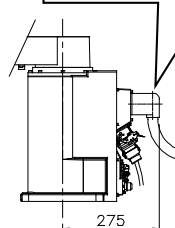

Clean specification

Note that the height described above is for RH-20FRH100xx. For RH - 20FRH 85xx, the height is the same as the ones described above.

### 2.3 Specifications of the controller

Please note that the controller model is new, and the dimensions and others have changed. For the details, refer to the following.

Item	Unit	Specifications			
		Old model	New model		
Controller model		RH-20SDH	RH-20FRH-D		
Routing control method		CR2DA-751	CR800-20HD		
Number of control axis		PTP control, CP control			
Programming language		Simultaneously 4			
		MELFA-BASIC V	MELFA-BASIC VI		
Memory capacity	Programmed positions	point	13,000	39,000	
	Number of steps	step	26,000	78,000	
	Number of programs		256	512	
External input/output (standard)	General-purpose input/output	point	Input 0/output 0 (Max. 256/256: option)	Input 0/output 0 (Max. 256/256: option)	
	Dedicated input/output		Assigned to general-purpose input/output	Assigned to general-purpose input/output	
	Dedicated stop input		1	1	
	Hand open/close		Input 8/output 0 (when using pneumatic hand interface: 8/8)	Input 8/output 8	
	Emergency stop input		1 (duplication)	1 (duplication)	
	Door switch input		1 (duplication)	1 (duplication)	
	Enabling device input		1 (duplication)	0	
	Emergency stop output		1 (duplication)	1 (duplication)	
	Mode output		1 (duplication)	1 (duplication)	
	Robot error output		1 (duplication)	1 (duplication)	
	Mode output selector input		0	1 (duplication)	
	Additional axis synchronization		1 (duplication)	1 (duplication)	
	Interface	RS-232	port	1	-
		RS-422	port	1 (for T/B)	
Ethernet		port	1 10BASE-T/100BASE-TX	1 (for T/B)/ 1 (for customer) 10BASE-T/100BASE-TX/1000BASE-T	
USB		port	1	1	
Memory expansion slot		SLOT	1	-	
Expansion slot		SLOT	1	2	
Robot input/output link		ch	1	1	
Additional axis function		ch	1 (SSCNETIII)	1 (SSCNETIII/H)	
Input power supply	Voltage range	V	Single phase, 180 to 253 VAC	Single phase, 200 to 230 VAC	
	Power capacity	kVA	2	1.5	
Outside dimensions	mm	470(W)×400(D)×200(H)		430(W)×425(D)×99.5(H)	
Mass	kg	Approx. 21		Approx. 12.5	
Construction [Protection specification]		Self-contained floor type, open type [IP20]			
Grounding	Ω	100 or less (D class grounding)			

### 2.4 Outside dimensions of the controller

The controller's outside dimensions have changed. (Left drawing: RH-20SDH controller, right drawing: RH-20FRH-D controller)

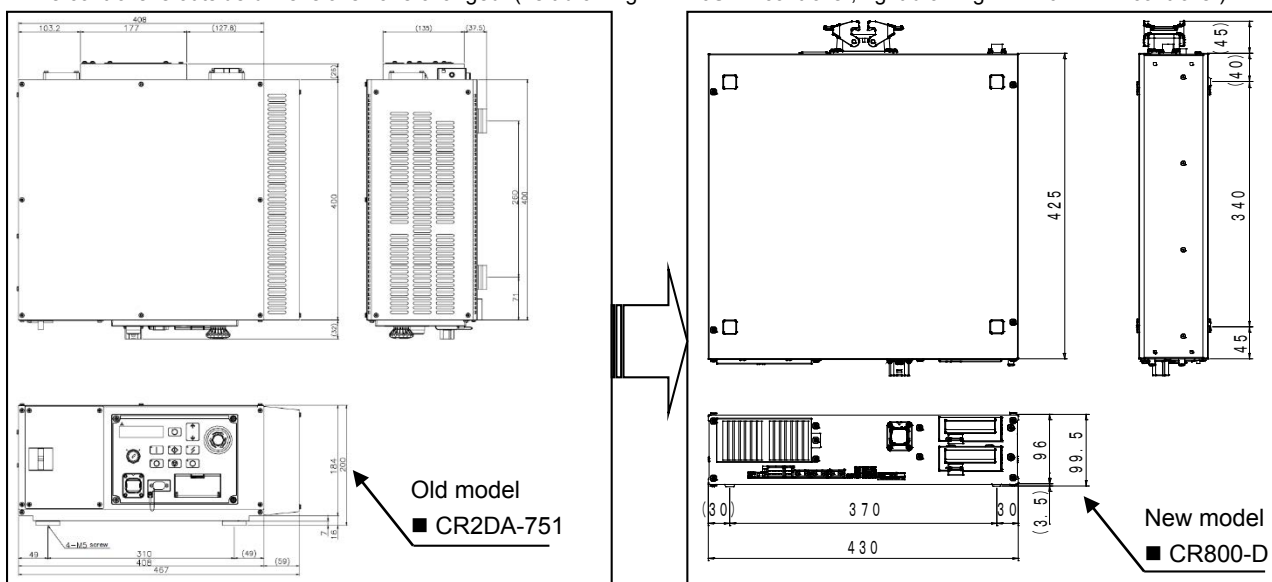

2.5 Options

(1) Robot arm options comparison

Item	Specifications			Specifications and supplementary explanation	Compatibility
	Old model	New model			
	RH-12SDH	RH-20FH-D			
Solenoid valve set	1S-VD0□M-03 (Sink type) 1S-VD0□ME-03 (Source type) □: 1 to 4	1S-VD0□-01 (Sink type) 1S-VD0□E-01 (Source type) □: 1 to 4		Solenoid valve set for the pneumatic hand (1 to 4 sets, sink type) Solenoid valve set for the pneumatic hand (1 to 4 sets, source type)	×
Hand output cable	1S-GR35S-02	1F-GR60S-01		The robot side has a connector, and the other side has drip-proof grommet attached output cables for unprocessed solenoid valve connection. (Total length: 1050mm)	×
Hand input cable	1S-HC35C-02	1F-HC35C-02		The robot side has a connector, and the other side has drip-proof grommet attached input cables for unprocessed hand sensor connection. (Total length: 1800mm)	×
Hand curl tube	1N-ST0608C	1N-ST0608C-01		φ6 × 8 pics, curl pneumatic tube for 4-set solenoid valve connection	×
Internal wiring/piping set for hand	-	1F-HS604S-01 1F-HS604S-02		8 hand inputs, φ6 x 4 tip axis built-in wiring piping set (with fixed plate)	-
User external wiring/piping box	-	1F-UT-BOX-01		Box for hand I/O wiring of 4-set solenoid valves and for external pullout of φ4 (8 pics) hand pipes	-
J1-axis operating range change	-	1S-DH-02		Stopper part for J1-axis operating range change	-
2m machine cable (replacement type)	1S-02UCBL-01	-		Fixed type (Set of 2 cables for power supply and signals), 2m (Provided as substitute for standard 5m cables.)	-
Machine cable (replacement type) (fixed type)	-	1F-□□UCBL-41 □□: 02, 10, 15, 20		Fixed type: 2m, 10m, 15m, 20m	-
Machine cable (replacement type) (flexed type)	-	1F-□□LUCBL-41 □□: 10, 15, 20		Flexed type: 10m, 15m, 20m	-
Machine cable extension (Fixed type)	1S-□□CBL-01 □□: 05, 10, 15	-		Fixed type (Set of 2 cables for power supply and signals), 5m, 10m, 15m (Used for adding to standard 5m cables.)	-
Machine cable extension (Flexed type)	1S-□□LCBL-01 □□: 05, 10, 15	-		Flexed type (Set of 2 cables for power supply and signals), 5m, 10m, 15m (Used for adding to standard 5m cables.)	-

Meaning of symbols in table:

○ : Same product  
× : Incompatible  
- : Not supported

(2) Robot controller options comparison

Item	Specifications		CR2DA-751/CR800-D compatibility	Remarks
	Old model	New model		
	CR2DA-751	CR800-20HD		
Pneumatic hand interface	2A-RZ365 (Sink) 2A-RZ375 (Source)	☆	○	
Expansion I/O unit	2A-RZ361 (Sink) 2A-RZ371 (Source)	2A-RZ361 (Sink) 2A-RZ371 (Source)	○	
External I/O cable	2A-CBL□□	2A-CBL□□	○	For expansion I/O unit
Build-in I/O interface	2D-TZ368 (Sink) 2D-TZ378 (Source)	2D-TZ368 (Sink) 2D-TZ378 (Source)	○	
External I/O cable	2D-CBL□□	2D-CBL□□	○	For built-in I/O interface
CC-Link interface	2D-TZ576	2D-TZ576	○	Ver. 2 compatible
Additional axis interface	☆	☆	☆	
Ethernet interface	☆	☆	☆	
Tracking function	☆	☆	☆	
Expansion memory	2D-TZ454	-	-	
Controller protection box	CR1D-MB	CR800-MB	×	
Teaching box		R32TB	○	
High-functionality teaching box		R56TB	○	
RS-232 cable (for PC support)	2D-232CBL03M	-	-	
Force sensor set	-	4F-FS002H-W200/4F-FS002H-W1000	-	
PC support software	3D-1□C-WINJ	3F-14C-WINJ	-	RT ToolBox3standard
		3F-15C-WINJ	-	RT ToolBox3min
		3F-16D-WINJ	-	RT ToolBox3Pro
Simulator (MELFA-Works)	3D-21C-WINJ		-	-

Meaning of symbols in table ○ : Compatible, ☆: Standard equipment, × : Incompatible, -: Not supported

### 3. Compatibility

The following table provides compatibility between old and new models.

#### 3.1 Compatibility of the robot arm

Category	Item	Specifications		Compatibility	Remarks
		Old model	New model		
		RH-20SDH	RH-20FH-D		
Outside dimensions	Installation dimensions	Changed		△1	Only the base length (depth) is incompatible.
	Mechanical interface	Changed		×	Incompatible (different shaft diameter)
	Operating range	Changed		○	Compatible (expanded operating area)
Tooling	Hand wiring	Changed		×	
	Hand piping	Changed		×	
	Backup wiring	Changed		○	Built-in LAN cable, also available as backup wiring.
Maintenance	Backup battery	A6BAT	MR-BAT6V1	×	

○: Fully compatible, ×: Incompatible, △1: Only the base length (external depth dimension + 30mm) is incompatible.

#### 3.2 Compatibility of the controller

Category	Item	Specifications		Compatibility	Remarks
		Old model	New model		
		CR2DA-751	CR800-20HD		
Operation	TB	R32TB		○	
	High-functionality TB	R56TB		○	
	I/O map	0 to 9999	0 to 9999	○	
	Programming language	MELFA-BASIC V	MELFA-BASIC VI	×	
	PC support software	RT ToolBox2	RT ToolBox3	×	
Maintenance	Backup battery	Q6BAT	-	×	

○: Fully compatible ×: Incompatible

#### Precautions of controller specifications

Item	Specifications	
	Old model	FR series
	CR2DA-751	CR800-20HD
Robot language	MELFA-BASIC IV MELFA-BASIC V	MELFA-BASIC IV cannot be used directly. (RT3 converts MELFA-BASIC IV into MELFA-BASIC V or VI.) MELFA-BASIC V MELFA-BASIC VI (upper-compatible of MELFA-BASIC V) *In MELFA-BASIC VI, the description method of program is the same as MELFA-BASIC V unless the Function or Include commands are used.
Serial number of robot	Necessary to input (by using the T/B or RT2)	Not necessary to input (The data has been stored in the robot's internal ROM.)
Origin setting	Necessary to input (by using the T/B or RT2)	Not necessary to input (The data has been stored in the robot's internal ROM.)
Hand type	Sink type (initial value) It is necessary to set a parameter for selecting the source type.	Not set (initial value) It is necessary to select either sink or source type by setting a parameter. (If not set, an error will occur.)
Mode selector input	Provided	Provided (Customer needs to prepare a mode selector switch.) Recommended key switch: HA1K-2C2A-2 (manufactured by IDEC)
Enabling device switch input	Provided	Not provided
Battery	Provided (Q6BAT, 1 pc.)	Not using (Not necessary to replace the battery)
TB dummy connector	Necessary	Not necessary After deadman turns on, the T/B can be removed without stopping the robot even during operation.

#### 3.3 Precautions of the extension function for GOT direct connection

The start addresses of the GOT shared memory (CPU buffer memory) I/O are different between old and new models.

Item	Specifications		Remarks
	Old model	FR series	
	CR2DA-751	CR800-20HD	
GOT output start address (to robot)	U3E0\G10000	U3E0\G0	
Robot input signal start address	10000	10000	
Robot output signal start address	10000	10000	
GOT input start address (from robot)	U3E1\G10000	U3E1\HG0	
Memory configuration	Shared memory among GOTs	CPU buffer memory	