



**MITSUBISHI  
ELECTRIC**  
**INVERTER**  
**INSTRUCTION MANUAL**

---

*DC Reactor*

**FR-HEL-C75K to C132K, C185K, C220K, C280K**

Thank you for choosing this Mitsubishi Inverter option. This instruction manual gives handling information and precautions for use of this equipment. Incorrect handling might cause an unexpected fault. Before using the equipment, please read this manual carefully to use the equipment to its optimum. Please forward this instruction manual to the end user.

## This section is specifically about safety matters

Do not attempt to install, operate, maintain or inspect this product until you have read through this instruction manual and appended documents carefully and can use the equipment correctly. Do not use this product until you have a full knowledge of the equipment, safety information and instructions.

In this instruction manual, the safety instruction levels are classified into "WARNING" and "CAUTION".



### **WARNING**

Assumes that incorrect handling may cause hazardous conditions, resulting in death or severe injury.



### **CAUTION**

Assumes that incorrect handling may cause hazardous conditions, resulting in medium or slight injury, or may cause physical damage only.

Note that even the  **CAUTION** level may lead to a serious consequence according to conditions. Please follow the instructions of both levels because they are important to personnel safety.

## SAFETY INSTRUCTIONS

### 1. Electric Shock Prevention



### **WARNING**

- Any person who is involved in the wiring or inspection of this equipment should be fully competent to do the work.
- Always install the inverter before wiring. Otherwise, you may get an electric shock or be injured.
- Do not touch the option with wet hands. You may get an electric shock.
- Do not subject the cables to scratches, excessive stress, heavy loads or pinching. Otherwise you may get an electric shock.

### 2. Fire Prevention



### **CAUTION**

- Mount the option to unflammable material. Mounting it to or near combustible material can cause a fire.

### 3. Injury Prevention



### **CAUTION**

- Apply only the voltage specified in the instruction manual to each terminal. Otherwise, burst, damage, etc. may occur.
- Ensure that the cables are connected to the correct terminals. Otherwise, burst, damage, etc. may occur.
- Always make sure that polarity is correct to prevent damage, etc. Otherwise, burst, damage may occur.
- While power is on or for some time after power-off, do not touch the option as it is hot. Otherwise, you may get burnt.

#### 4. Additional Instructions

Also note the following points to prevent an accidental failure, injury, electric shock, etc. Assumes that incorrect handling may cause an accidental failure, injury, electric shock, etc.

##### 1) Transportation and installation

 <b>CAUTION</b>		
<ul style="list-style-type: none"> <li>• When carrying products, use correct lifting gear to prevent injury. Special attention must be paid to the edges of the product.</li> <li>• Do not install or operate the option unit if it is damaged or has parts missing.</li> <li>• Do not stand or rest heavy objects on the product.</li> <li>• Check that the mounting orientation is correct.</li> <li>• Prevent other conductive bodies such as screws and metal fragments or other flammable substance such as oil from entering the option.</li> <li>• As the option is a precision instrument, do not drop or subject it to impact.</li> <li>• Use the inverter under the following environmental conditions. Otherwise, the inverter may be damaged.</li> </ul>		
<b>Environment</b>	Surrounding air temperature	-10°C to 50°C (non-freezing)
	Ambient humidity	90% RH or less (non-condensing)
	Storage temperature	-20°C to 65°C *1
	Atmosphere	Indoors (free from corrosive gas, flammable gas, oil mist, dust and dirt)
	Altitude/vibration	Maximum 1000m above sea level 5.9m/s <sup>2</sup> or less at 10 to 55Hz (directions of X, Y, Z axes)
<p>*1 Temperature applicable for a short time, e.g. in transit.</p> <ul style="list-style-type: none"> <li>• If halogen-based materials (fluorine, chlorine, bromine, iodine, etc.) infiltrate into a Mitsubishi product, the product will be damaged. Halogen-based materials are often included in fumigant, which is used to sterilize or disinfect wooden packages. When packaging, prevent residual fumigant components from being infiltrated into Mitsubishi products, or use an alternative sterilization or disinfection method (heat disinfection, etc.) for packaging. Sterilization or disinfection of wooden package should also be performed before packaging the product.</li> </ul>		

##### 2) Trial run

 <b>CAUTION</b>
<ul style="list-style-type: none"> <li>• Before starting operation, confirm and adjust the parameters. A failure to do so may cause some machines to make unexpected motions.</li> </ul>

##### 3) Operation

 <b>WARNING</b>
<ul style="list-style-type: none"> <li>• Do not modify the equipment.</li> <li>• Do not perform parts removal which is not instructed in this manual. Doing so may lead to fault or damage of the inverter.</li> </ul>

##### 4) Disposal

 <b>CAUTION</b>
<ul style="list-style-type: none"> <li>• Treat as industrial waste.</li> </ul>

##### (5) General instruction

All illustrations given in this manual may have been drawn with covers or safety guards removed to provide in-depth description. Before starting operation of the product, always return the covers and guards into original positions as specified and operate the equipment in accordance with the manual.

# Contents

<b>1</b>	<b>Product Checking.....</b>	<b>2</b>
<b>2</b>	<b>Installation .....</b>	<b>2</b>
<b>3</b>	<b>Wiring .....</b>	<b>3</b>
<b>4</b>	<b>Cable Size and Crimping Terminal .....</b>	<b>4</b>
<b>5</b>	<b>Specifications .....</b>	<b>5</b>
<b>6</b>	<b>Outline Dimension Drawings .....</b>	<b>5</b>
	<b>APPENDIX.....</b>	<b>8</b>



# 1 Product Checking

- (1) Unpack the option unit, and ensure that the product received is as you ordered and it is intact.

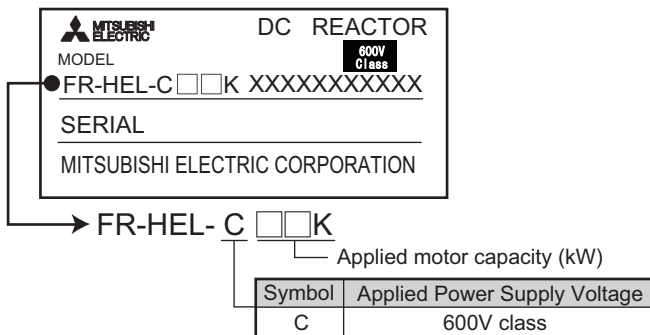

- (2) Make sure that the package includes all accessories.

DC reactor (FR-HEL-C).....	1
----------------------------	---

# 2 Installation

- (1) Install the reactor horizontally according to the environment conditions specified on *page 5*. Installing the reactor in an unspecified direction will damage the reactor.
- (2) Take full caution not to make the surrounding air temperature higher than the permissible value (-10°C to +50°C). In addition, as the reactor itself generates heat, leave sufficient clearance around it. (Independent of the installation direction of the reactor, 10 cm or more for the above and below, 5 cm or more for the right and left)

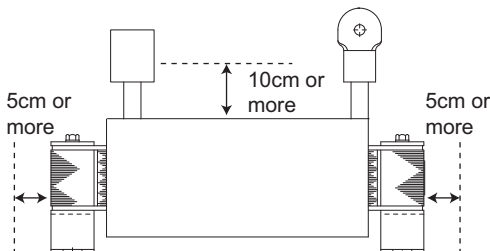



## 3 Wiring

- (1) When using the inverter equipped with a jumper across terminals P1 and P, remove the jumper and connect the reactor across terminals P1 and P.
  - Minimize the connection cable between the reactor and inverter so that the length is within 5m. (For the size of the cable, refer to *page 4*)
  - When using the inverter equipped with a jumper across terminals P1 and P, remove the jumper. Otherwise, the reactor will not exhibit its performance.

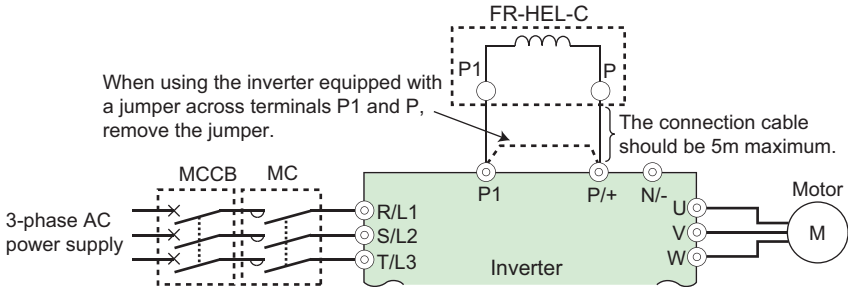

- (2) Make selection according to the applied motor capacity. (When the inverter capacity is larger than the motor capacity, make selection according to the motor capacity.)
- (3) Securely earth (ground) the reactor using the earth (ground) terminal.

### CAUTION

1. Do not perform wiring while power is on and the inverter is running.
2. Any person who is involved in the wiring of this equipment should be fully competent to do the work.
3. Since high-voltage is applied to the inverter terminals P1, P and N, fully make sure that the input power is off and the voltage across terminals P and N is not exceeding 50VDC before performing wiring.
4. Provide isolation treatment to avoid contact of terminals.



## 4 Cable Size and Crimping Terminal

Refer to *page 3* for the wiring of terminals P and P1 and the earthing cable.

Model	P, P1				Earth (ground) cable	
	Terminal bolt size	Tightening torque* N•m	Crimping terminal	AWG/MCM	Crimping terminal	AWG/MCM
FR-HEL-C75K	M10	26.5	60-10	1/0	38-6	1
FR-HEL-C90K	M10	26.5	70-10	2/0	38-6	1
FR-HEL-C110K	M10	26.5	80-10	3/0	38-6	1
FR-HEL-C132K	M12	46.1	100-12	4/0	38-6	1
FR-HEL-C185K	M12	46.1	150-12	300	38-6	1
FR-HEL-C220K	M12	46.1	100-12	2×4/0	60-6	1/0
FR-HEL-C280K	M12	46.1	150-12	2×300	100-8	4/0

\* Torque value (reference value) for the iron bolts with the 4.6 strength rating. Use the tightening torque recommended for the applied bolt.



# 5 Specifications

<b>Power factor improving effect *1</b>		Power supply power factor approx. 93%(94.4%) (at 100% load)
<b>Power specifications</b>		Three-phase 525 to 600VAC 60Hz
<b>Environment</b>	<b>Surrounding air temperature</b>	-10°C to + 50°C (non-freezing)
	<b>Ambient humidity</b>	90%RH or less (non-condensing)
	<b>Storage temperature</b>	-20°C to + 65°C (non-freezing)
	<b>Atmosphere</b>	Indoors (free from corrosive gas, flammable gas, oil mist, dust and dirt)
	<b>Altitude/vibration</b>	Max.1000m above sea level 5.9m/s <sup>2</sup> or less

\*1 The power factor is calculated on the assumption that the power impedance is 1%. The value changes according to the power supply capacity and power impedance. The load is calculated using the fundamental current specified in JEM-TR201 as 100%. The value is 94.4% when calculated with 1 power factor for the fundamental wave according to the Architectural Standard Specifications (Electrical Installation) (2013 revision) supervised by the Ministry of Land, Infrastructure, Transport and Tourism of Japan.

# 6 Outline Dimension Drawings

•FR-HEL-C75K

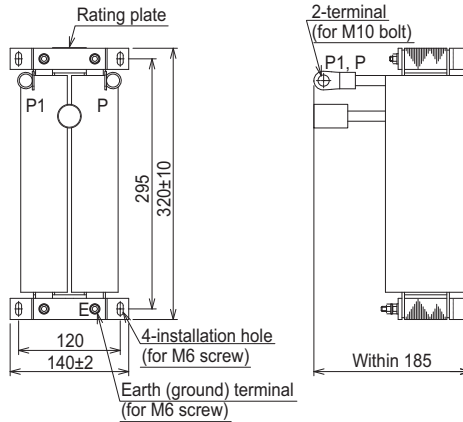

Model	Motor capacity	Mass (kg)
FR-HEL-C75K	75kW	16

Unit (mm)



•FR-HEL-C90K to C132K

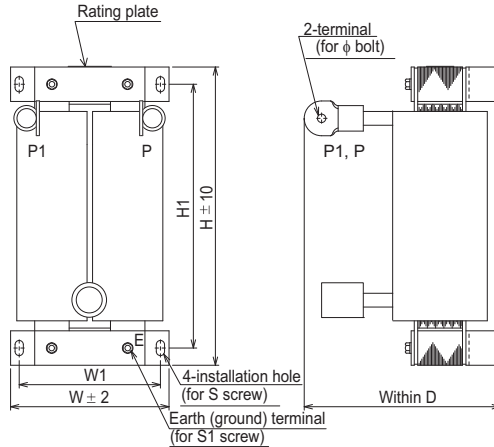

Model	Motor capacity	W	W1	H	H1	D	S	S1	φ	Mass (kg)
FR-HEL-C90K	90kW	150	130	340	310	190	M6	M6	M10	20
FR-HEL-C110K	110kW									23
FR-HEL-C132K	132kW	175	150	405	370	195	M8	M12	24	

Unit (mm)



•FR-HEL-C185K, C220K, C280K

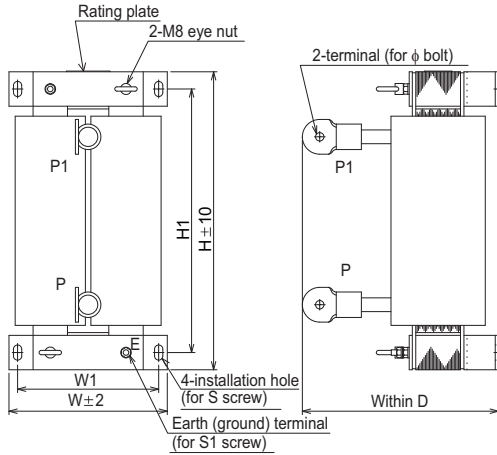

\* Remove the eye nut after installation of the product.

Model	Motor capacity	W	W1	H	H1	D	S	S1	φ	Mass (kg)
FR-HEL-C185K	185kW	175	150	405	370	240	M8	M6	M12	32
FR-HEL-C220K	220kW									33
FR-HEL-C280K	280kW	190	165	440	400	250		M8		40

Unit (mm)



## APPENDIX

---

### *Appendix 1 Applicable inverters*

The FR-HEL-C series are a UL Listed accessory for use only with the following UL listed inverter models:

- 600V class

DC reactor model	Applicable inverter models
FR-HEL-C75K	FR-A860-01080, 01440, 01670 FR-F860-01080, 01440, 01670 FR-AF860-01080, 01440, 01670
FR-HEL-C90K	FR-A860-01440, 01670, 02430 FR-F860-01440, 01670, 02430 FR-AF860-01440, 01670, 02430
FR-HEL-C110K	FR-A860-01670, 02430, 02890 FR-F860-01670, 02430, 02890 FR-AF860-01670, 02430, 02890
FR-HEL-C132K	FR-A860-02430, 02890 FR-F860-02430, 02890 FR-AF860-02430, 02890
FR-HEL-C185K	FR-A860-03360, 04420 FR-F860-03360, 04420 FR-AF860-03360, 04420
FR-HEL-C220K	FR-A860-03360, 04420 FR-F860-03360, 04420 FR-AF860-03360, 04420
FR-HEL-C280K	FR-A860-04420 FR-F860-04420 FR-AF860-04420

\* For the FR-A860-01440 or higher inverters and the FR-F860-01440 or higher inverters and the FR-AF860-01440 or higher inverters, or whenever a 75 kW or higher motor is used, always connect the FR-HEL-C according to the combination table.



## Appendix 2 Compatibility with conventional models

The FR-HEL-C series reactor selected using the inverter-reactor combination table (*page 8*) is compatible with the conventional model as shown in the table below.

If the compatible conventional model is already obtained, it can be used as is.

FR-HEL-C series reactor	Conventional model
FR-HEL-C75K	BKO-CA1901H01
FR-HEL-C90K	BKO-CA1901H02
FR-HEL-C110K	BKO-CA1901H03
FR-HEL-C132K	BKO-CA1901H04
FR-HEL-C185K	BKO-CA1901H06
FR-HEL-C220K	BKO-CA1901H07
FR-HEL-C280K	BKO-CA1901H09

# MEMO

# MEMO

## REVISIONS

\*The manual number is given on the bottom left of the back cover.

Print Date	*Manual Number	Revision
Feb. 2015	IB(NA)-0600587ENG-A	First edition
Oct. 2016	IB(NA)-0600587ENG-B	Addition • Compatibility with the FR-F860 series and the FR-AF860 series

# **mitsubishi electric corporation**

HEAD OFFICE: TOKYO BUILDING 2-7-3, MARUNOUCHI, CHIYODA-KU, TOKYO 100-8310, JAPAN