

# MELFA FAMILY

## Industrial robots



- Collaborative robots
- 6 axes and SCARA robots
- High-performance controllers
- Programming software
- Simulation

# Global impact of Mitsubishi Electric



Through Mitsubishi Electric's vision, "Changes for the Better" are possible for a brighter future.

## *Changes for the Better*

We bring together the best minds to create the best technologies. At Mitsubishi Electric, we understand that technology is the driving force of change in our lives. By bringing greater comfort to daily life, maximising the efficiency of businesses and keeping things running across society, we integrate technology and innovation to bring changes for the better.

Mitsubishi Electric is involved in many areas including the following

### **Energy and electric systems**

A wide range of power and electrical products from generators to large-scale displays.

### **Electronic devices**

A wide portfolio of cutting-edge semiconductor devices for systems and products.

### **Home appliance**

Dependable consumer products like air conditioners and home entertainment systems.



### **Information and communication systems**

Commercial and consumer-centric equipment, products and systems.

### **Industrial automation systems**

Maximising productivity and efficiency with cutting-edge automation technology.

# Contents

Features in detail	<b>4-5</b>	
Work alongside human operators	<b>6-7</b>	
Precision and flexibility	<b>8-9</b>	
The technology in detail	<b>10-11</b>	
Software for industrial robots	<b>12</b>	

Section 2: Technical information

# Features in detail

## Robots from € 1.65/hr

Calculated on the basis of their average service life, around 6–7 years in typical applications, Mitsubishi Electric robots have a surprisingly low total cost of ownership at around € 1.65 per hour for both purchasing and operation.



## Versatility

Small robots have been used in more than 60,000 applications in widely differing fields since 1978 – and what is more they work around the clock, 24 hours a day, 7 days a week.



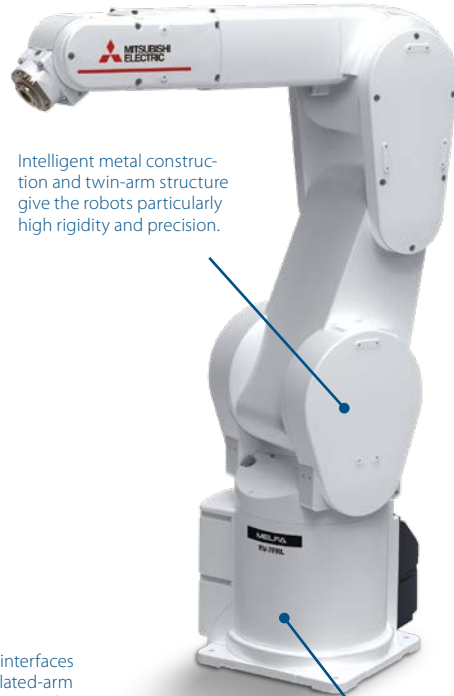

Intelligent metal construction and twin-arm structure give the robots particularly high rigidity and precision.



The gripper interfaces of the articulated-arm robots conform to the ISO 9409-1 standard.

Mitsubishi Electric servo motors of the latest generation help to provide exceptional repeatability performance.

A very compact design takes up minimum space for applications in cramped quarters.

## Simple programming

A powerful range of robots needs an equally powerful and user-friendly programming interface. Mitsubishi Electric's RT ToolBox3 packages are powerful programming and simulation software tools tailored precisely for the needs of your robots.



## Network capabilities

Network connections like Ethernet, Profibus, PROFINET, EtherCAT, DeviceNet® and CC-Link make it easy to integrate Mitsubishi Electric robot controllers in to larger systems, providing users with access to every step of the process.



# Work alongside human operators

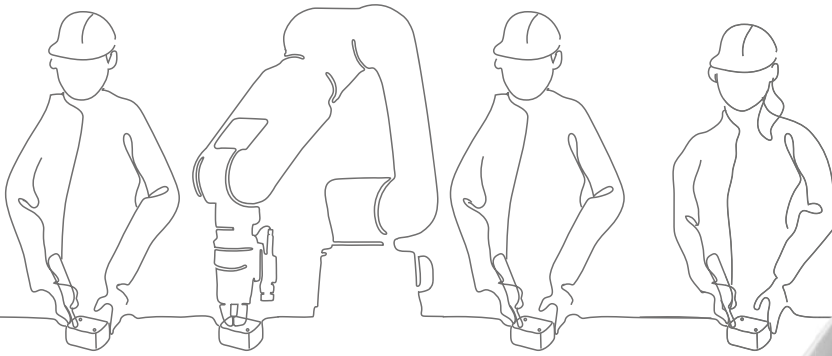

## MELFA assist<sup>a</sup>

### Integrate. Collaborate.

Mitsubishi Electric's collaborative robot, the MELFA ASSISTA, has been developed to work alongside human operators without the need for guards or safety fences, while meeting new requirements for adequate distancing of workers in manufacturing sites. The cobot offers maximum safety, such as collision detection and strict compliance with the international safety and robotic standards ISO 10218-1 and ISO/TS15066. Furthermore, it offers durability combined with ease of use and programming, while maintaining very high positional repeatability of  $\pm 0.03$  mm\* by a rated payload of 5 kg and reach radius of 910 mm.

\* Commonly offered repeat accuracy by cobots of  $\pm 0.1$  mm.

### Easy control

#### Fast and intuitive robot setup via dedicated control panel

Robot movements can be taught and recorded quickly via a dedicated control panel on the cobot arm, doing away with separate teaching boxes required for conventional industrial robots.

The control panel features a simple design with a minimum number of buttons for simplicity, enabling even inexperienced users without expert knowledge of robots to set up the system with ease.

A bright, always visible 6 colour LED ring mounted around the robot's forearm clearly displays the status of the robot.

### Easy programming

#### Simplified application development using intuitive flow-chart programming

The RT VisualBox programming tool developed by Mitsubishi Electric enables operating sequences to be created intuitively by linking block diagrams in a chain of events, including connection with other devices such as robot hands and cameras. Fast program-development and design time help to reduce system TCO.

## Easy connecting

### A wide variety of components and applications

ASSISTA offers a wide variety of components – grippers, fingers, vision and other peripherals – developed by a group of organizations known as MELFA robot partners.

These tools can easily be setup and configured for your application.

ASSISTA can also be configured to move freely as part of an AGV/AMR\* or as a mobile robot.

\* AGV: Automated Guided Vehicle  
AMR: Autonomous Mobile Robot

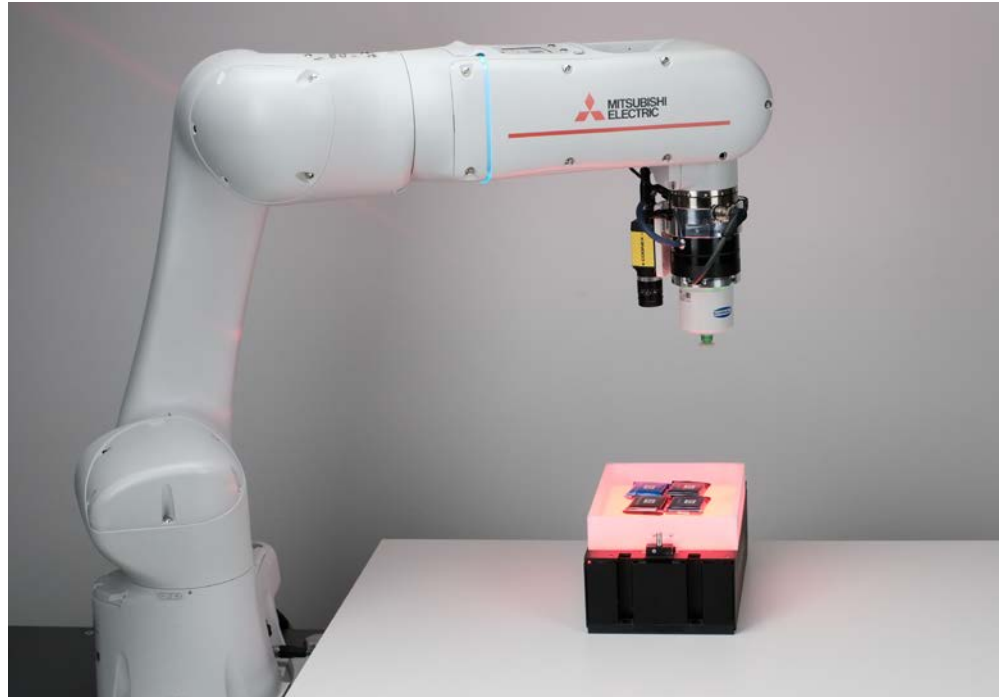

## Grip with ASSISTA

### Simply connect grippers to robot arm

The ASSISTA set-up wizard provides operators with an easier more intuitive methodology for gripper configurations.

## View with ASSISTA

### “RT VisualBox” proprietary engineering tool

The vision camera focus adjustment and work registration can be configured simply by touching the screen. This means that you can use it even without special robot knowledge.



# Precision and flexibility

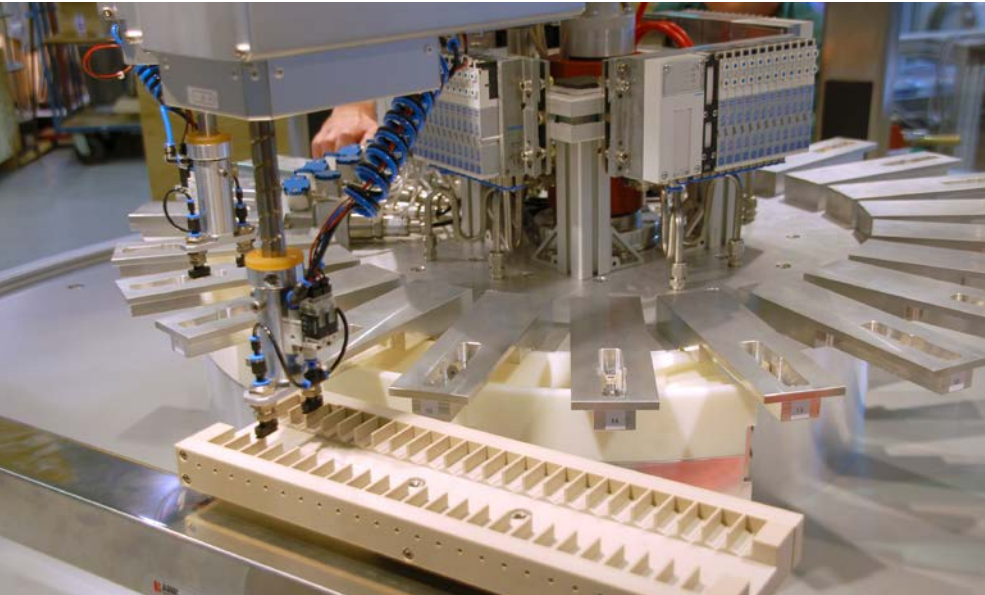

## Pharmaceutical industry

Modular control concepts and pharmaceutical industry certification make MELFA robots the ideal partner in the life sciences sector. Integral database connection and an all-embracing control concept facilitate modular and flexible applications in any field where quality and production data have to be backed up in a comprehensible manner.



## Food and drink

Increasing hygiene demands, a variety of products and the traceability of production processes are ensured with MELFA robots – now and in the future.

Innovative details and stringent guidelines for MELFA robots guarantee assured quality even in ultra-clean applications.

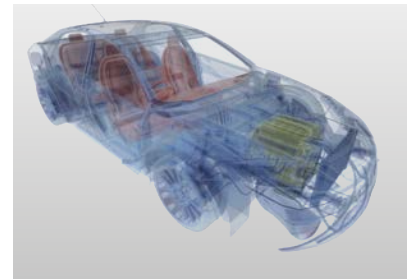

## Automotive industry

Highly accurate and extremely flexible MELFA robots are used whenever every little detail matters – haptic measurement, quality assurance and assembly of complex components. MELFA robots carry out their tasks around the clock and at full speed.



## Packaging

High-performance and flexibility are a matter of course for MELFA robots. It goes equally without saying that all Mitsubishi Electric automation components can be incorporated. These include additional axes, PLC controllers and operating terminals. Furthermore, cameras can be connected and robots synchronised with conveyor belts. These functions enable packaging tasks to be carried out reliably, quickly and continuously.

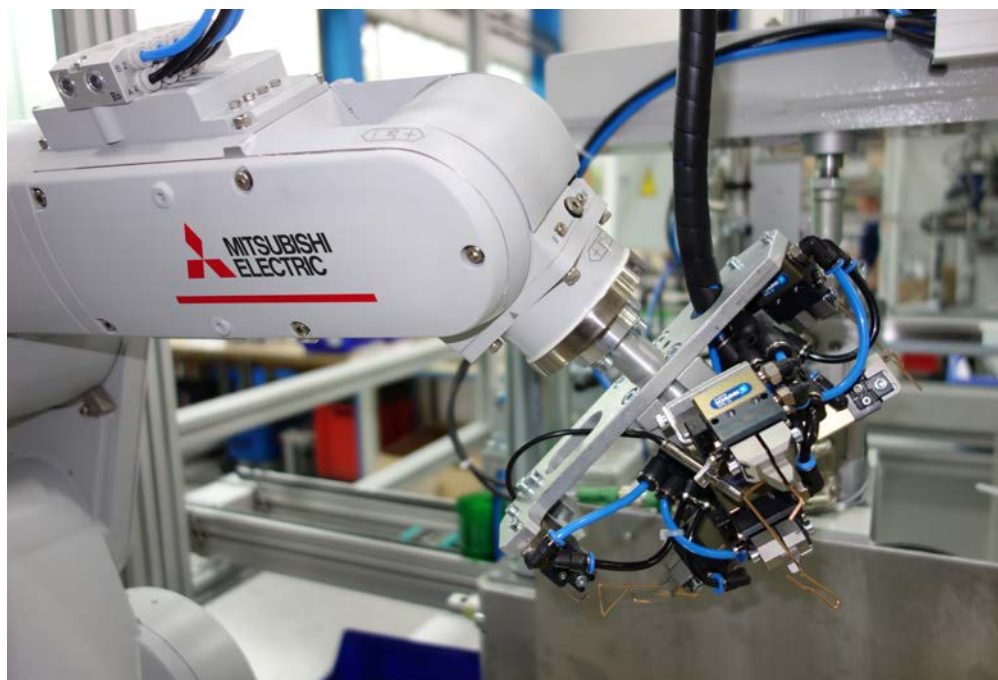

## Electronics and mechanical engineering

Mitsubishi Electric provides a wide range of products from SCARA robots for the micro assembly of miniature components to fully sealed articulated arm robots. There are no applications which are not suitable for MELFA robots. Whether cleanroom or dirty, oily and dusty environments, the product range always includes the right robot for your application.

## Training

Learning from practical experience – a goal which can be achieved in a training environment with the compact, lightweight MELFA robots. Simple programming, simulation options and experienced teachers make entry into the field of robotics easy.

No limits – thanks to standard real-time interfaces and simple programming, MELFA robots provide all sorts of options for using the robots as manipulators, even for complex university research projects.

# The technology in detail



## More safety

The DIN ISO-10218 safety standard is common to all robots and therefore guarantees safe operation in all applications. Mitsubishi Electric's supplementary product range including safety controllers enables the robots to be integrated into a common safety concept. Ready-made example projects make it possible for anyone to put together even complex systems quickly and effectively.

The optional "MELFA SafePlus" safety technology for the FR series robot controllers has functions available like reduced safe speed control, safe limited control range and safe torque monitoring, which can be activated via safety inputs. Logic for each safe I/O can be edited and in combination with the position monitoring function a safe system can be constructed without using a Safety PLC.

Based on these functions, saving of safety equipment and a reduction of safeguarded space is possible which leads to a reduction of cost and space while meeting all safety requirements at the same time.

## Sensor-controlled robots with image processing

Mitsubishi Electric's industrial robots can be connected to any object recognition camera system via the Gigabit Ethernet interface of the robot con-

troller. This enables static and moving parts to be detected with the correct positional information.

The possible uses of sensor-controlled robots in factory automation are manifold. They range from component assembly via quality control and the re-working of workpieces to the location and removal of objects from a conveyor belt.

## FR-R series – full PLC functionality in the robot

As robots are never installed on a stand-alone basis, the system must be easy to integrate into its working environment to enable it to communicate with PLC and motion systems as well as operating panels and other systems. Together with the modular robot CPU, the Mitsubishi Electric iQ Platform provides the ideal basis for integrating the full functionality of a PLC into the robot controller – once again demonstrating the company's role as a pioneer in automation technology.

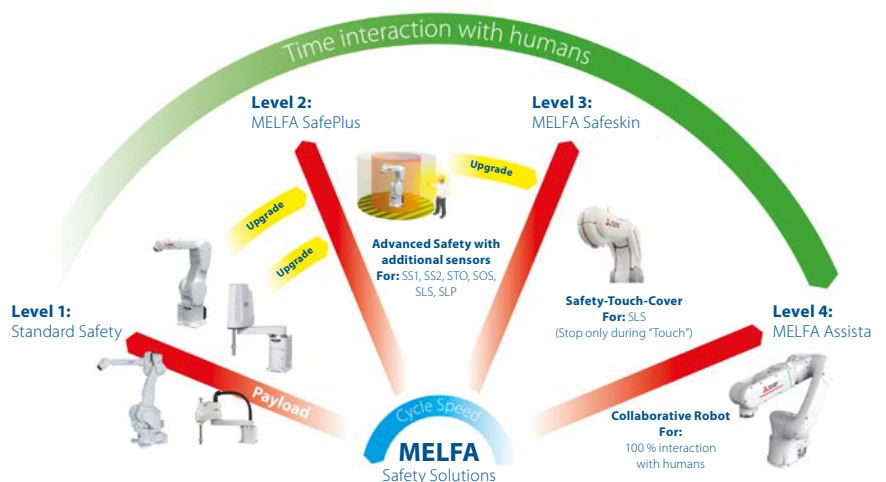

## Simple integration into complex applications

Up to eight additional axes can be connected directly to the robot controller with just one cable. Of these, two axes can be used as additional interpolating axes, e.g. as the seventh and eighth robot axis.

The special feature compared with other systems is that all additionally connected axes can be programmed in exactly the same way as the robot, using the same Teach-Box or the standard RT ToolBox3 software. This avoids the additional expense of software, training and programming.

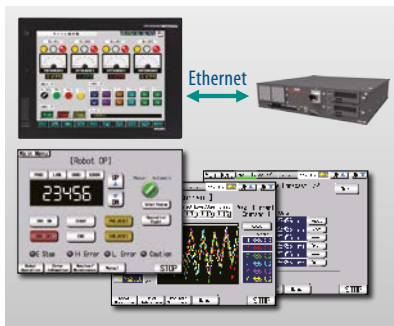
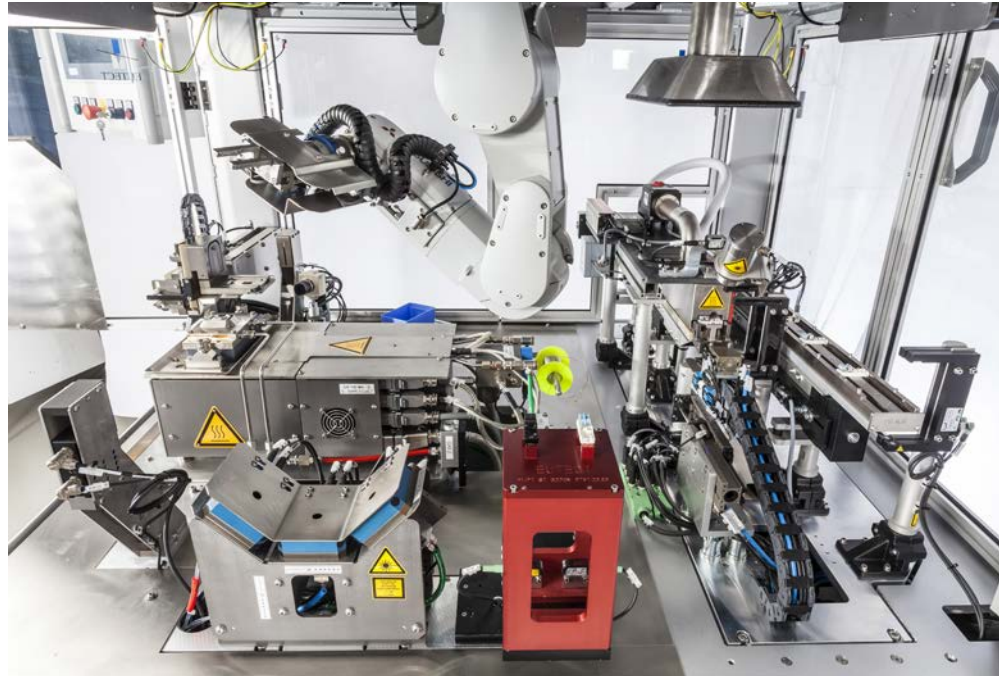

## More efficient monitoring and maintenance functions

Direct connection of the company's infrastructure GOT operating terminal via Ethernet opens up a number of monitoring, control and maintenance functions for the robot. The correction of taught points, the backup and restore function, the entry of production data, and the selection and control of processes are just some of the options provided by the Mitsubishi Electric operating terminal in conjunction with MELFA robots.

## Open communication for PC connection

The robot controller can be connected to an MES system, for example for easily and quickly changing manufacturing sequences without stopping production.

Furthermore, the robot can be initiated for any kind of movement in real time. Flexible and complex movements, which are generated graphically on the PC, for example, can be realised in this way.

# Programming and simulation

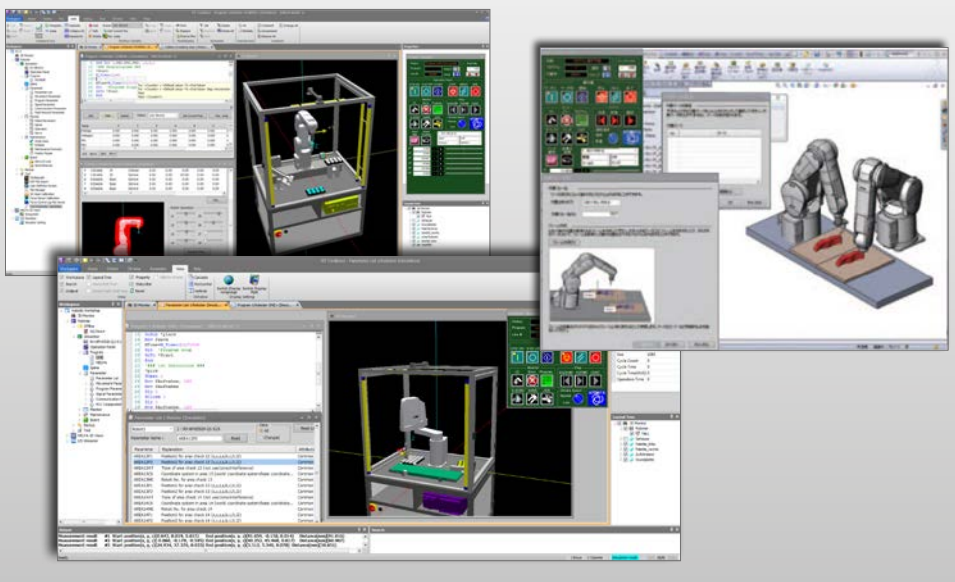

Simulation of a Mitsubishi Electric industrial robot directly in an application

High-performance industrial robots also require high-performance software. For this reason, more and more automation engineers are opting for the versatile and convenient Mitsubishi Electric software. All tasks, such as the creation of projects, programming and simulation, are implemented intuitively and mesh perfectly with one another. This results in optimum movement sequences in the shortest possible installation and commissioning time.

## Programming

Offline and online programming with simulation

## Simulation

3D-CAD import and up to 16 robots can be simulated in one project; additional axes can be connected and positions taught directly in the simulation.

## Parameters

Parameter structure for the simple parameterisation of functions; complete overview of all parameters with display of modified values only.

## Maintenance

Full backup and restore function and monitoring of service intervals, production runtimes and product cycles.

## Monitoring

Display of load currents, position values, variables and variable positions. Monitoring of switching signals, program execution and fault history.

## Documentation

Full project documentation with output of modified parameters, program code and positions.

## 3D-simulation with RT ToolBox3 Pro

The RT ToolBox3 Pro add-in tool for SolidWorks enables MELFA robots to be simulated in the CAD environment on a PC, and converts the workpiece paths into robot position data.

Supplementing the SolidWorks platform by the addition of RT ToolBox3 Pro extends the simulation functions and opens up new simulation possibilities.

- The CAD data of the system can be directly imported
- Grippers can be connected directly to the robot
- Handling of workpieces
- Offline teaching in a 3D environment
- Creation of robot programs
- Collision-checking between robot and system environment

## RT VisualBox

The RT VisualBox programming tool is an intuitive engineering software for MELFA ASSISTA for quick, easy system deployment. It enables operating sequences to be created intuitively by linking block diagrams in a chain of events, including connection with other devices such as robot hands and cameras.

## The convenient operating terminal for mobile teaching

The R56TB is a powerful operating panel for carrying out all tasks directly at the robot, from controlling the robot and displaying the loads by means of the input/output display to complete program creation and parameterisation. The comprehensive functions ensure optimum utilisation of the robot system and thus reduce setup times.

The integral USB port enables data to be exchanged conveniently, and complete controller backups can be uploaded and downloaded through a memory stick.



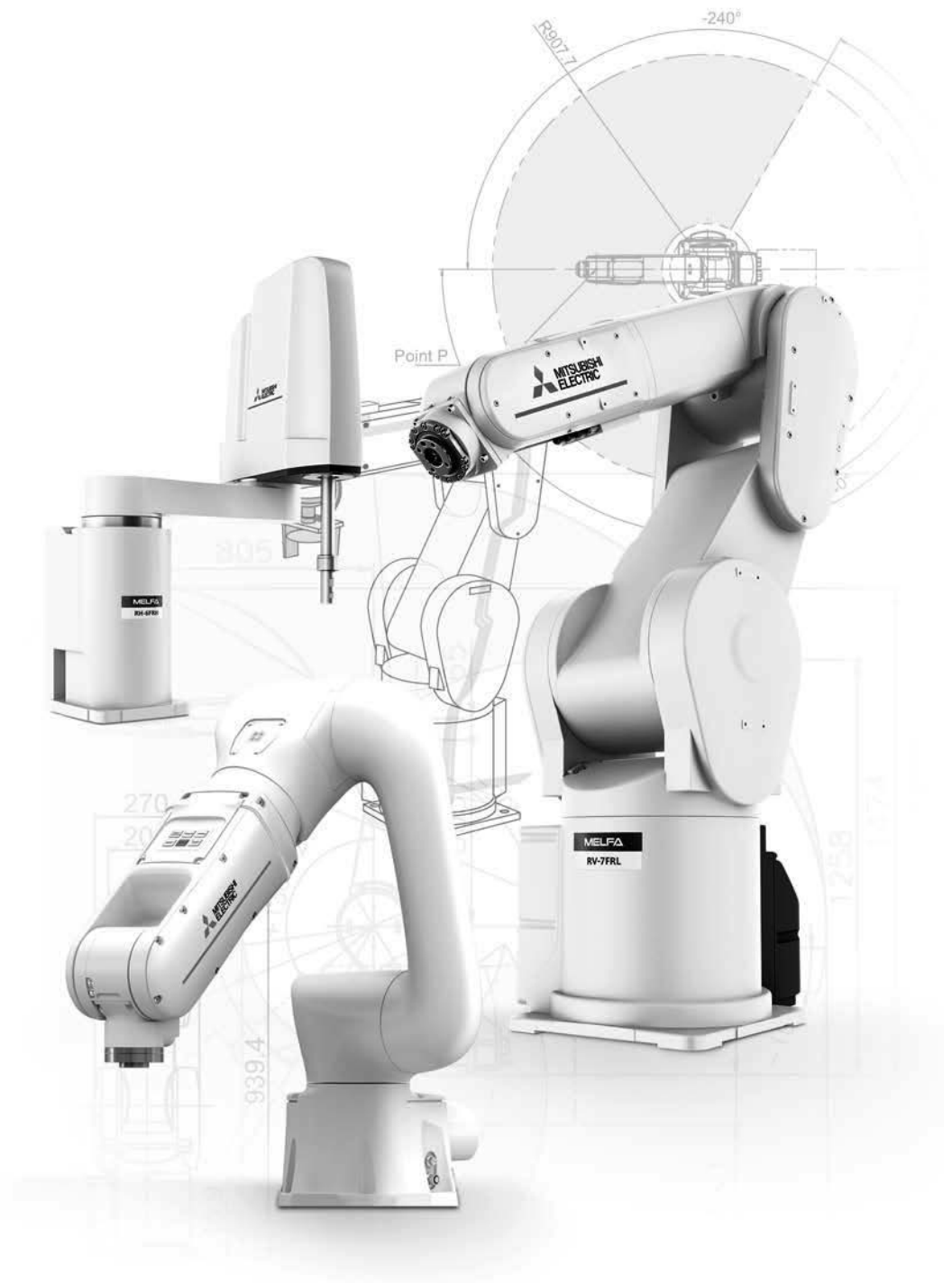

## Technical Information Section

## Further publications within the Mitsubishi Electric family

**Brochures**  
<https://eu3a.mitsubishielectric.com/fa/en/service/download>

### HMI family

Product catalogue for operator terminals, supervision software and accessories  
<https://eu3a.mitsubishielectric.com/fa/en/dl/11153/207075.pdf>

### MR family

Product catalogue for servo amplifiers and servo motors as well as motion controller and accessories  
<https://eu3a.mitsubishielectric.com/fa/en/dl/5886/209265.pdf>

### Compact PLC family

Product catalogue for compact programmable logic controllers and accessories for the MELSEC FX family  
[https://eu3a.mitsubishielectric.com/fa/en/dl/835/C\\_FX\\_Family\\_I\\_UK\\_167840.pdf](https://eu3a.mitsubishielectric.com/fa/en/dl/835/C_FX_Family_I_UK_167840.pdf)

### Modular PLC family

Product catalogues for modular programmable logic controllers and accessories for the MELSEC iQ-R series, MELSEC System Q, and MELSEC L series  
[https://eu3a.mitsubishielectric.com/fa/en/dl/9774/C\\_iQ-R\\_Q\\_L-Family\\_D\\_UK\\_260570.pdf](https://eu3a.mitsubishielectric.com/fa/en/dl/9774/C_iQ-R_Q_L-Family_D_UK_260570.pdf)

### FR family

Product catalogue for frequency inverters and accessories  
<https://eu3a.mitsubishielectric.com/fa/en/dl/4976/206313.pdf>

### LVS family

Product catalogue for low voltage switchgears, magnetic contactors and circuit breakers  
<https://eu3a.mitsubishielectric.com/fa/en/dl/6481/216798.pdf>

### Automation book

Overview on all Mitsubishi Electric automation products, like frequency inverters, servo/motion, robots etc.  
<https://eu3a.mitsubishielectric.com/fa/en/dl/2341/170021.pdf>

---

### Further service supplies

This product catalogue is designed to give an overview of the extensive range of Mitsubishi Electric MELFA RV and RH series. If you cannot find the information you require in this catalogue, there are a number of ways you can get further details on configuration and technical issues, pricing and availability.

For technical issues visit the <https://eu3a.mitsubishielectric.com> website. Our website provides a simple and fast way of accessing further technical data and up to the minute details on our products and services. Manuals and catalogues are available in several different languages and can be downloaded for free.

For technical, configuration, pricing and availability issues contact our distributors and partners. Mitsubishi Electric partners and distributors are only too happy to help answer your technical questions or help with configuration building. For a list of Mitsubishi Electric partners please see the back of this catalogue or alternatively take a look at the "contact us" section of our website.

### About this product catalogue

This catalogue is a guide to the range of products available. For detailed configuration rules, system building, installation and configuration the associated product manuals must be read. You must satisfy yourself that any system you design with the products in this catalogue is fit for purpose, meets your requires and conforms to the product configuration rules as defined in the product manuals.

Specifications are subject to change without notice. All trademarks acknowledged.

© Mitsubishi Electric Europe B.V., Factory

**The products of Mitsubishi Electric Europe B.V., that are listed and described in this document, are neither subject to approval for export nor subject to the Dual-Use List.**

## 1 Robots

- ◆ Overview robots ..... 4
- ◆ Standard high end functions ..... 9
- ◆ Industrial robots RV-2FR(L)(B) ..... 19
- ◆ Industrial robots RV-4FRLM ..... 21
- ◆ Industrial robots RV-7FRM/7FRLM/7FRLLM ..... 23
- ◆ Industrial robots RV-13FRM/RV-13FRLM/RV-20FRM ..... 25
- ◆ Industrial robots RV-35F/50F/70F ..... 27
- ◆ Industrial robots RV-5AS ..... 29
- ◆ Industrial robots RV-8CRL ..... 31
- ◆ Industrial robots RH-1FRHR ..... 33
- ◆ Industrial robots RH-3FRHR ..... 35
- ◆ Industrial robots RH-FRH ..... 37
- ◆ Industrial robots RH-CRH ..... 40
- ◆ Industrial robots RD-1F500/RD-1F800/RD-1F1100/RD-1F1300 ..... 42
- ◆ System overview ..... 43

## 2 Controller

- ◆ Controller ..... 44
- ◆ Dimensions of the control units ..... 45

## 3 Accessories

- ◆ Teaching box ..... 46
- ◆ Force sensor, MELFA SafePlus ..... 47
- ◆ MELFA Smart Plus card, MELFA Smart Plus card pack ..... 48
- ◆ Wiring set ..... 49
- ◆ Valve sets, bellows ..... 50
- ◆ Interface boards ..... 51
- ◆ Adaptor cables, connectors ..... 52
- ◆ Tubes, extension cables ..... 53
- ◆ PC and I/O connection cables, controller protection box, buffer batteries ..... 54
- ◆ General overview of options ..... 55

## 4 Programming language

- ◆ MELFA-BASIC ..... 57

## 5 Software

- ◆ RT Toolbox3 ..... 58
- ◆ RT Toolbox3 Pro ..... 59
- ◆ RT VisualBox ..... 60

- Index ..... 61

# Overview robots

## A complete lineup

### Large range of robot models makes selection easy

Mitsubishi Electric produces a comprehensive range of robot models to cater to the full spectrum of modern needs. All Mitsubishi Electric robots are powerful, fast and compact – that goes almost without saying.

The product range includes the almost universal articulated-arm robots with 6 degrees of freedom and payloads of 2 kg to 70 kg and SCARA robots with 4 degrees of freedom and payloads of 3 kg to 20 kg for assembly and palletising tasks.

Three special models are available, the unique collaborative robot MELFA ASSISTA with a payload of 5 kg, which can share a workspace with humans, the low cost model RV-8CRL as well as the flexible high-speed SCARA robots for ceiling mounting.

### Vertical, multiple-joint type (RV)



Type	RV-2FR(B)	RV-2FRL(B)	RV-4FRL	RV-7FR	RV-7FRL	RV-7FRLL
Number of axis	6	6	6	6	6	6
Payload kg	2	2	4	7	7	7
Maximum reach radius mm	504	649	649	713	908	1503
Environmental specifications	Standard type	IP30	IP40	IP40	IP40	IP40
	Oil mist type	—	IP67	IP67	IP67	IP67
	Cleanroom type	—	ISO class 3	ISO class 3	ISO class 3	ISO class 3
	Special type	—	ESD/ATEX	ESD/ATEX	ESD/ATEX	ESD/ATEX
Controller	CR800-D/CR800-R + R16RTCPU					

### Horizontal, multiple-joint type (RH)



Type	RH-1FRHR	RH-3FRHR	RH-3FRH5515N	RH-6FRH5520N	RH-12FRH8535N	RH-20FRH10035N
Number of axis	4	4	4	4	4	4
Payload kg	1	3	3	6	12	20
Maximum reach radius mm	550	350	550	550	850	1000
Environmental specifications	Standard type	IP20 (IP65 optional)	IP20 (IP65 optional)	IP54 (IP65 optional)	IP54 (IP65 optional)	IP54 (IP65 optional)
	Cleanroom type	—	ISO class 5	ISO class 3	ISO class 3	ISO class 3
	Special type	—	—	ESD	ESD	ESD
Controller	CR800-D/CR800-R + R16RTCPU					



**Advanced intelligence, safety and integration**

The concept of FR robots offers a simple approach to advanced and flexible production to handle all automation needs. This concept is based on 3 key features

- Intelligence: “MELFA Smart Plus” offers greater accuracy and shorter startup times, making installation simpler and more advanced tasks possible.
- Safety: A comprehensive range of safety functions, including position and speed monitoring, allow work to be conducted in cooperation with people
- Integration: MELSEC iQ-R compatible robot controller and the e-F@ctory integrated FA solution offers seamless integration of robots and IT systems.



RV-13FR	RV-13FRL	RV-20FR	RV-35F ①	RV-50F ①	RV-70F ①	RV-5AS	RV-8CRL
6	6	6	6	6	6	6	6
13	13	20	35	50	70	5	8
1094	1388	1094	2050	2050	2050	910	931
IP40	IP40	IP40	IP40	IP40	IP40	IP54 (ISO class 5)	IP65
IP67	IP67	IP67	IP67	IP67	IP67	—	—
ISO class 3	ISO class 3	ISO class 3	—	—	—	—	—
ESD/ATEX	ESD/ATEX	ESD/ATEX	—	—	—	Food grade H1 grease	—



CR800-D/CR800-R + R16RTCPU

CR760 ①

CR800-D



RH-3CRH	RH-6CRH	RD-1F500 ①	RD-1F800 ①	RD-1F1100 ①	RD-1F1300 ①
4	4	4	4	4	4
3	6	2	3	3	3
400	600/700	500	800	1100	1300
IP20	IP20	IP65	IP65	IP65	IP65
—	—	—	—	—	—
—	—	IP69K	IP69K	IP69K	IP69K



CR800-D

CR750 ①

① Please contact your Mitsubishi Electric representative for more details.

## Overview robots

### Mitsubishi Electric collaborative robot "ASSISTA"

#### Simpler and easier

Robots work with people and work next to people in busy workplaces.

Simpler, easier and more flexible.

It is a robot for you that changes the image of the robot.

- Easy control

The operating buttons on the robot arm provide you with easy control for ASSISTA and the teaching pendant for programming and teaching is no longer needed.

The LED on the robot arm display the status of the robot.

- Easy programming

You can create programs visually using intuitive operations with RT VisualBox.

"Visual programming" – This software allows operators to simply program this robot with a "train by demonstration" programming interface. This allows them to move the robot arm position and set waypoints easily.



- Easy connecting

ASSISTA offers a wide variety of components-Grippers, Fingers, Vision and other peripherals-developed by our e-F@ctory Alliance partners.

These tools can easily be setup and configured for your application.

ASSISTA can also be configured to move freely as part of an AGV/AMR or as a mobile robot.

(AGV:Automated Guided Vehicle, AMR:Autonomous Mobile Robot)

### Grip with ASSISTA

#### Simply connect grippers to robot arm

The ASSISTA set-up wizard provides operators with an easier more intuitive methodology for gripper configurations.

Recommended electric-powered gripper:

- Co-act EGP-C40-N-N-ASSISTA (SCHUNK)
- HRC-03-099455 (ZIMMER)
- KIT-ASSISTA-G (GIMATIC)
- ROB-SET ECBPM ASSISTA (SCHMALZ)



### View with ASSISTA

ASSISTA and the camera capture the target using the "RT VisualBox" auto-focus function.

#### "RT VisualBox" proprietary engineering tool

The vision camera focus adjustment and work registration can be configured simply by touching the screen. This means that you can use it even without special robot knowledge.

#### Vision sensor in-sight

The high-performance camera identifies the target and fixes position at high speed. Its compact size makes it ideal for attaching to the ASSISTA robot hand. This wire-saving type is equipped with PoE.

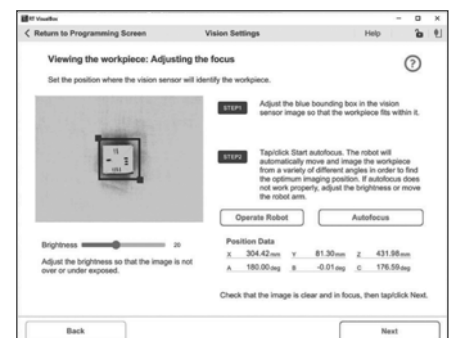

Screenshot RT VisualBox

Model designation



RV-7FRLM



RV-5AS



RV-8CRL

Vertical, multiple-joint type (RV)

RV-□FR□M-□-□□□

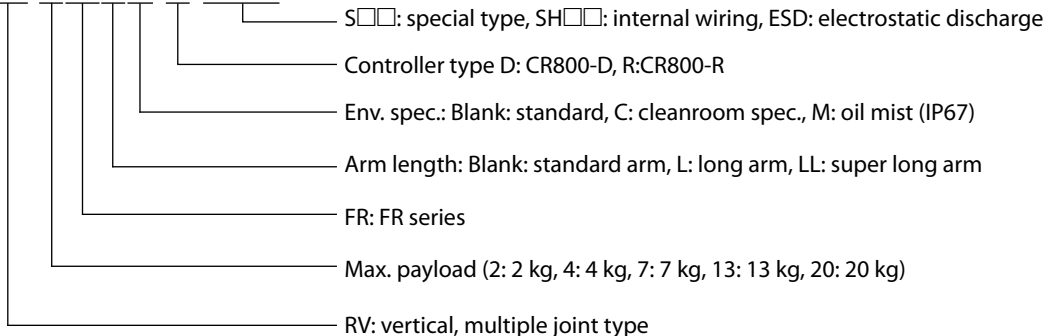

RV-□AS-D-□□□

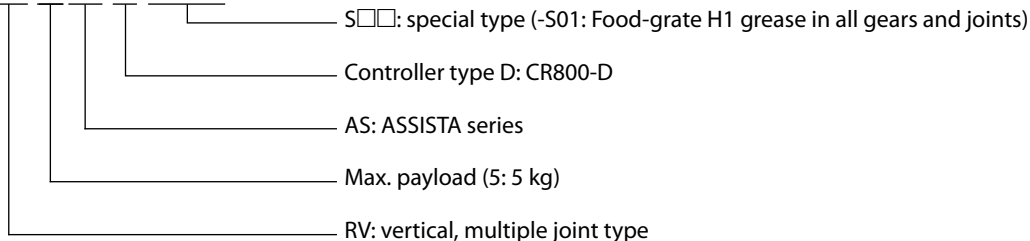

RV-□CRL-D-□□□

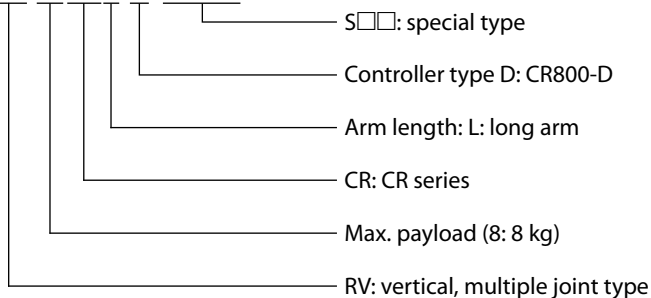

Model designation



RH-1FRHR5515



RH-6FRH5520N



RH-3CRH4018

Horizontal, multiple-joint type (RH)

RH-□FRH□□N-□-□□□

- : special type, ESD: electrostatic discharge
- Controller type: D: CR800-D, R:CR800-R
- Env. spec.: Blank: standard, C: cleanroom spec., M: oil mist (IP67), N: IP54 and H1 grease
- Stroke length: 12: 120 mm, 15: 150 mm, 20: 200 mm, 34: 340 mm, 35: 350 mm, 45: 450 mm
- Arm length: 35: 350 mm, 45: 450 mm, 55: 550 mm, 70: 700 mm, 85: 850 mm, 100: 1000 mm
- FRH: FR series, FRHR: FR series ceiling type
- Max. payload (1: 1 kg, 3: 3 kg, 6: 6 kg, 12: 12 kg, 20: 20 kg)
- RH: horizontal, multiple joint type

RH-□CRH□□□□-D-□□□

- : special type
- Controller type D: CR800-D
- Stroke length: 18: 180 mm, 20: 200 mm
- Arm length: 40: 400 mm, 60: 600 mm, 70: 700 mm
- CRH: CRH series
- Max. payload (3: 3 kg, 6: 6 kg)
- RH: horizontal, multiple joint type

Shortened takt times

Improved control performance

Produced the fastest operating performance in its class using high-performance motors and unique driver control technology developed by Mitsubishi Electric.

- Enabled high torque output at high rotational speed, shortening acceleration/deceleration time
- Shortened positioning time for improved device throughput
- Continuous operability improved

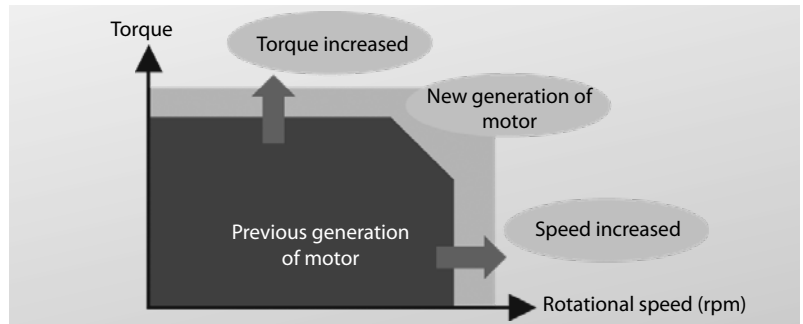

Tooling performance

Internal routing of hand wiring and signal cable

- Internal routing of cables and air hoses
- No interference with cables around devices
- Reduced risk of wiring disconnection
- Optional models of RV with internal wiring and hoses up to the hand are available (-SH□□)

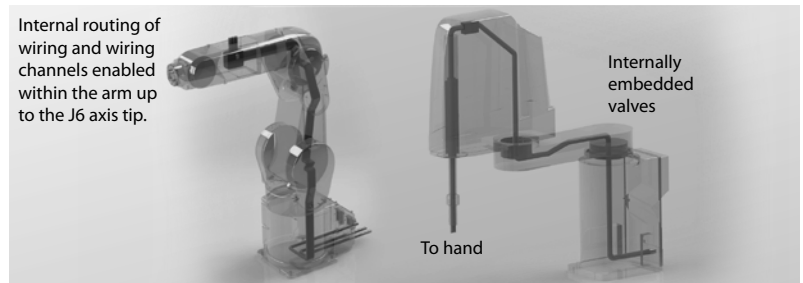

Flexibility with internal Ethernet cable tools

Internal installation of wiring and piping for connecting to vision sensors enabled.

- Hand: 8 input points/8 output points
- Ethernet cable for the vision sensor
- Additional cables to control vision systems or other sensors

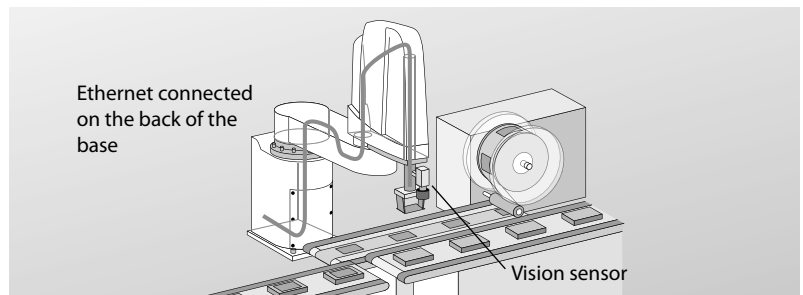

Full use of installation space

Expanded pivotal operating range

- Improved flexibility for robot layout design
- More effective use of access space around the entire perimeter
- Shortened movement distances, enabling takt times to be shortened

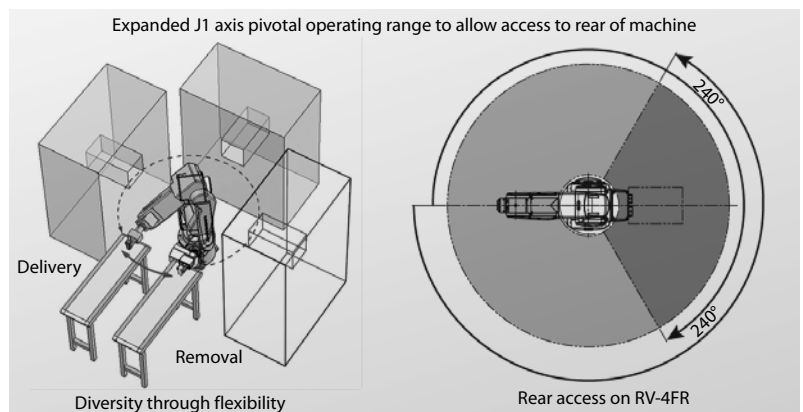

# Standard high end functions

## User friendliness

### Simple automatic operation from the teaching box

- Same functions as on the operating panel of the robot controller
- Monitoring screens can be set up individually to match the needs of user debugging conditions
- Enabled for R32TB and R56TB
- User definition screens for customized operation screens and monitoring

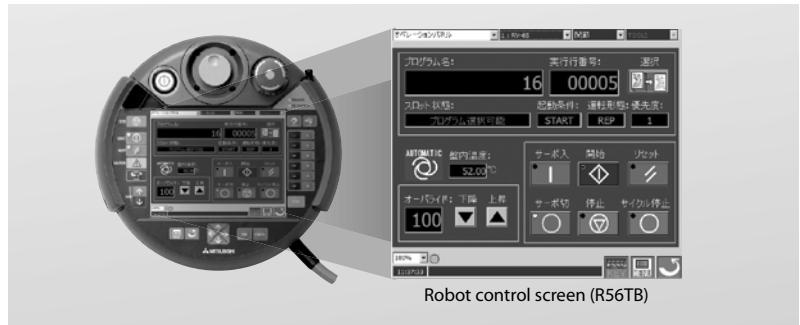

Enables automatic operation of servo motor on/off, startup and shutdown, reset, program selection, and other operations.

### HMI backup/restore functions (Supported on GT14, GT15, GT16, GT21, GT23, GT25 and GT27)

Robot data on the GOT can be backed up to and restored from a CF-/SD-card or USB memory stick. Due to the direct Ethernet connection a PC is not required

- This helps prevent data from being lost due to the empty battery/battery or robot malfunction.
- Data can be saved after periodic maintenance tasks are performed or when unexpected errors occur. Dramatically improves serviceability



### Maintenance (log function)

Information before and after errors occur (state changes, I/O, external system variables, etc.) and program run states can automatically be transferred to an FTP server as log data or saved on an SD card. Operation logs can also be downloaded, enabling efficient analysis of error causes.

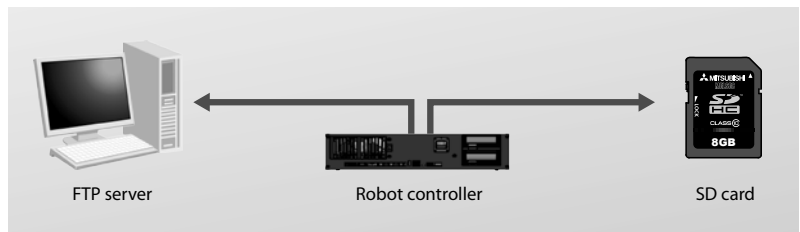

### Easier robot information management

Memory is included in the robot body and used to store robot-specific information. This makes it easy to switch robot controllers.

Information can also be collected without visiting the workplace, simplifying the formulation of maintenance plans.

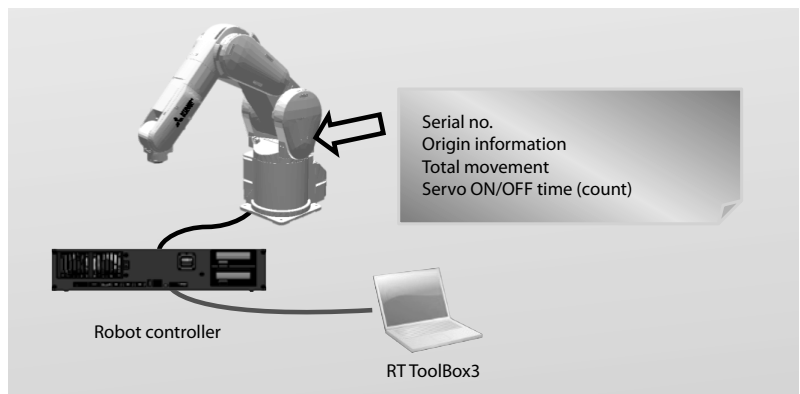

**High accuracy**

**Active gain control**

- Optimal motor control tuning settings in real-time based on robot operating position, posture and load conditions
- Improved palletization accuracy
- Improved trajectory accuracy
- Faster positioning without overshooting

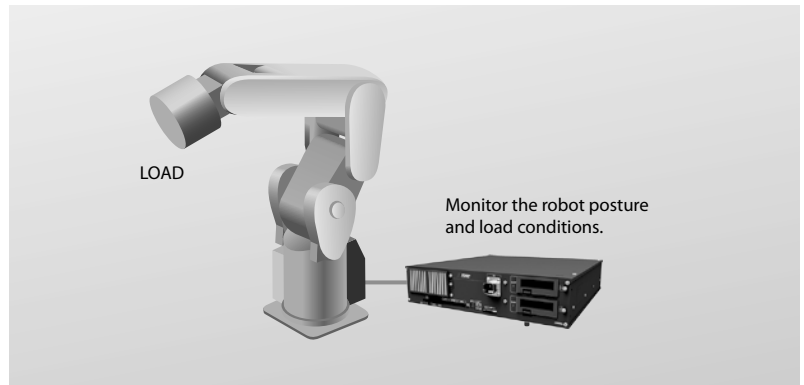

**Simplified tool length setting**

Tool settings for the tool coordinate system can be set by attaching the tool and using three to eight of the same teaching points.

- Eliminates errors introduced when the tool was made
- Higher precision
- Saving time, since measuring the tool is not necessary

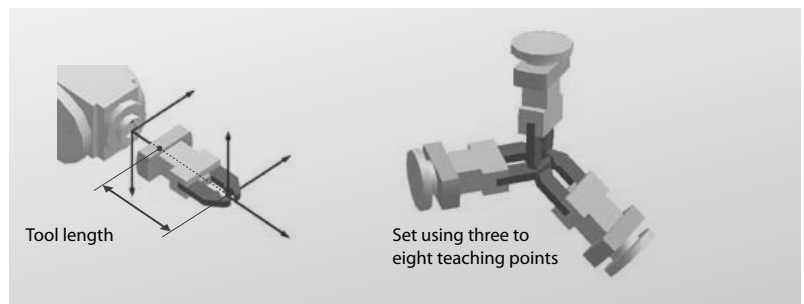

**Adaptation to operation**

**Compliance control**

This function reduces the rigidity of the robot arm and tracks external forces.

- Special hands and sensors are unnecessary
- Reduced tooling costs
- Shortened line stop times

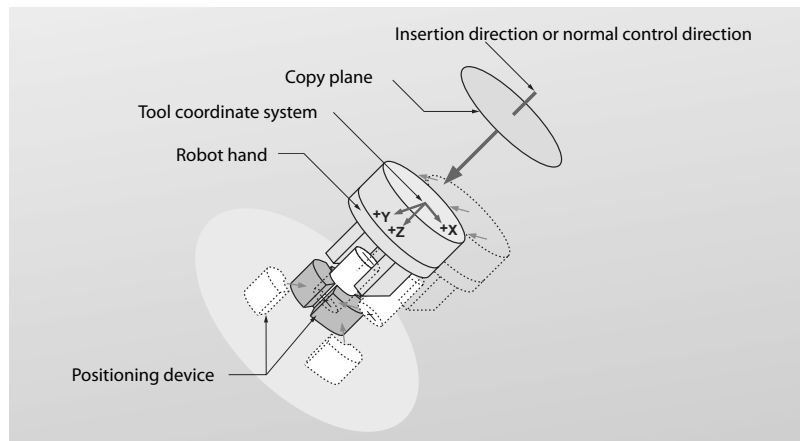

**Collision detection function**

This function detects if the arm collides with an obstacle while teaching or operation, and helps to reduce damaging the robot arm and tools. The detection level can be changed according to the protection targets.

The operation which should follow after the collision detection can be programmed to suit to the application, for example stop immediately and show error or retract and show then the error.

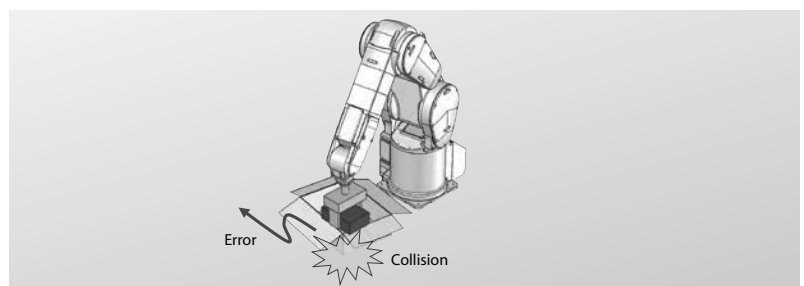

# Standard high end functions

## ■ Connection to peripheral devices

### Network vision sensor

The robot and camera can be easily simultaneously calibrated through a simple process using vision sensor setting tools.

- Simple connection between the robot and camera using Ethernet
- Simple control using vision control commands in the robot programs
- Shortened takt times
- Reduced system costs

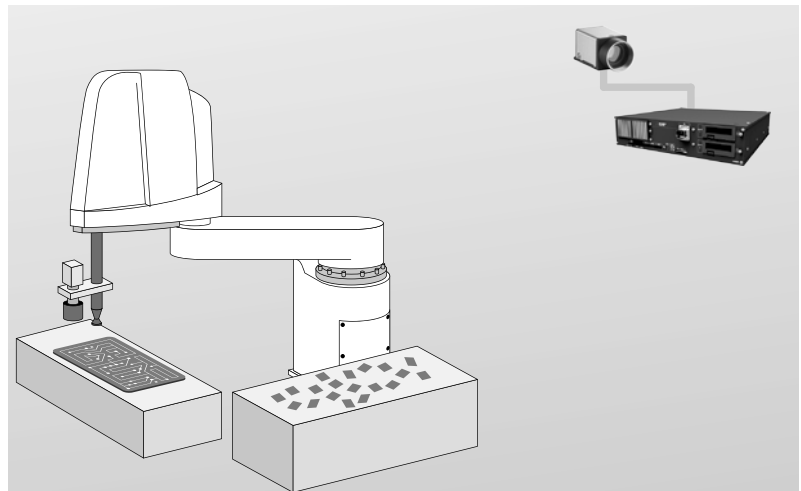

### Tracking

Transport, alignment, and installation work, etc. can be performed while robots are tracked with the workpiece on the conveyor without stopping the conveyor.

- Higher throughput of components
- Easy programm creation (MELFA BASIC V/VI)
- No need for an additional positioning device
- Prediction of workpiece position for better tact times
- Circular tracking available

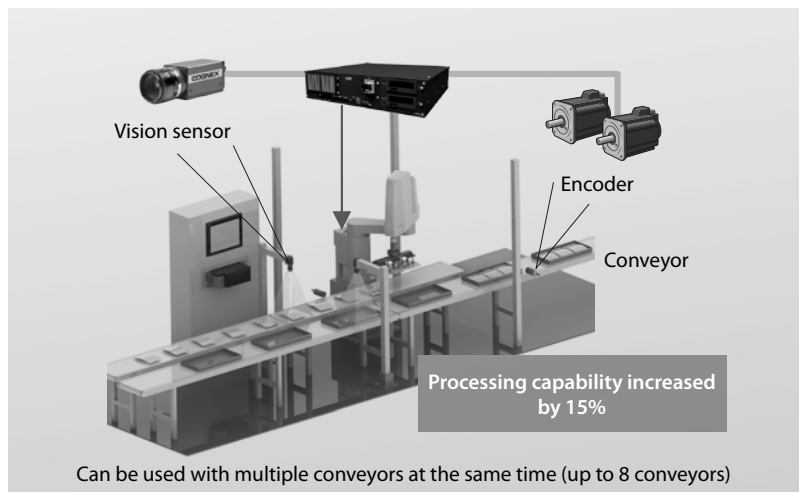

### Additional axis function

The layout can be set up to include the robot traveling axis and turntable as well as user machines separate from the robot such as loaders and positioning devices.

- Up to 8 additional axes can be controlled by the controller
- No additional motion control hardware necessary
- Rotary and linear servomotors are supported
- Plug-and-play compatibility with the MELSERVO MR-J4-B servos
- Two axes can be controlled simultaneous with the robot
- No need of special programming knowledge, because robot software is used

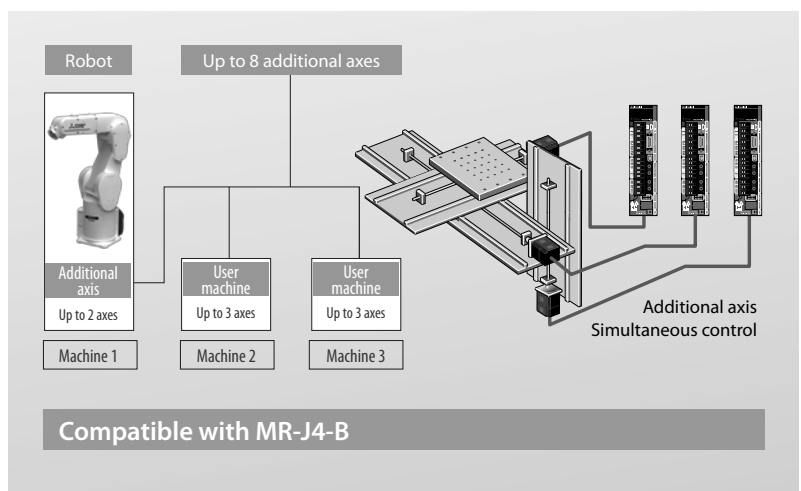



## ■ CC-Link IE Field Network Basic function

FR series robot controller supports the slave stations of “CC-Link IE Field Network Basic” as a built-in function

- CC-Link IE Field Network Basic compatible products and Ethernet compatible products can be connected on the same Ethernet communications line
- MELSEC iQ-R/iQ-F/Q/L series PLC CPU and the MELFA FR series robot controller have built-in Ethernet as standard, so no dedicated option is required
- enabling a highly-flexible and cost-effective system

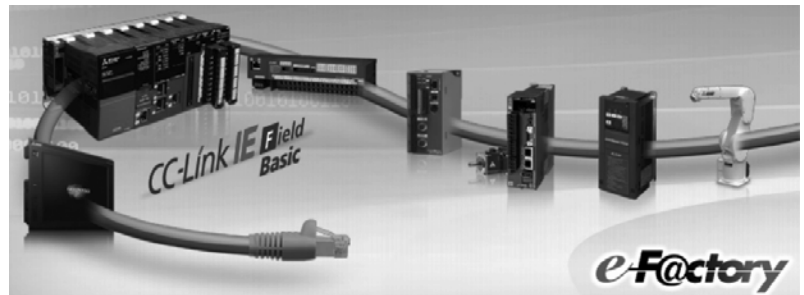

## ■ Collision avoidance (R type controllers only)

The robot is stopped, even before collisions can occur. This is possible due to the fast position control, that is implemented in the iQ Platform as a standard feature.

- Robots can operate together in a confined space without interfering with each other
- Reduces the number of recovery man-hours required after a collision
- Already represented in the simulation of the RT ToolBox3
- Can be used in Teach-Mode already

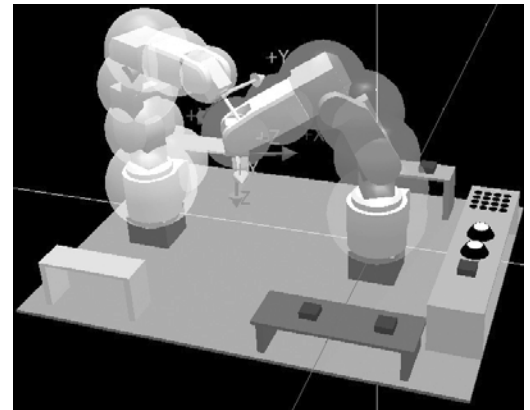

Possible collisions with other robots are avoided.

## ■ Coordinated control (R type controllers only)

Enables coordinated control between multiple robots through CPU connection between the robots.

- Easy to operate by predefined default function
- Enables transport of lengthy or heavy objects using small-sized robots
- Programming as already known by using standard commands



Enables installation work to be completed while gripper positions between robots are maintained.

# Standard high end functions

## Intelligent technology

### Force sensor

- Monitors the force applied to the robot gripper to handle processes like a human operator
- Keeps the force constant so that the workpiece can be handled without causing damage
- Complex assembly tasks achieved through techniques such as phase matching
- Force log function for checking the quality check

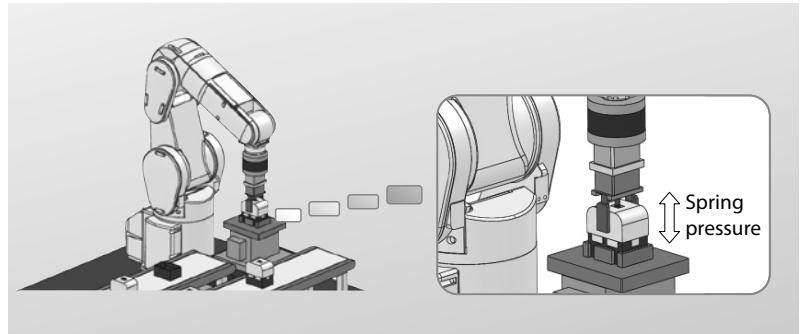

### Arm temperature compensation

- Monitors temperature of motor encoders
- Improves positioning accuracy by compensating for thermal expansion in the robot arm

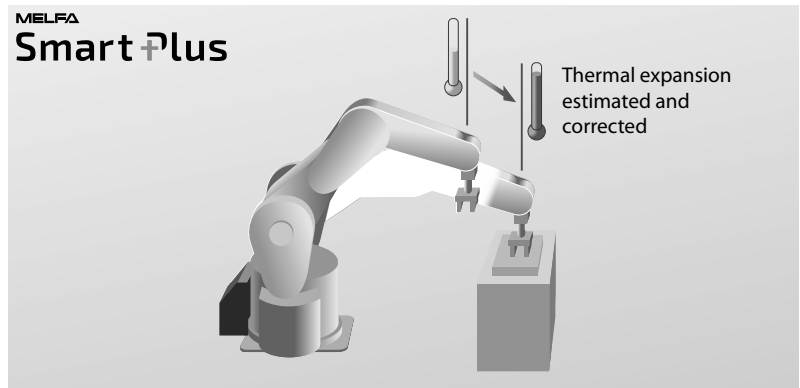

### Calibration assistance

- Reduces the time for calibration during start up and improves position accuracy
- Automatically correcting the robot and camera coordinates
- Automatically correcting the robot and workpiece coordinates
- Adjust the robot location relative to other robots

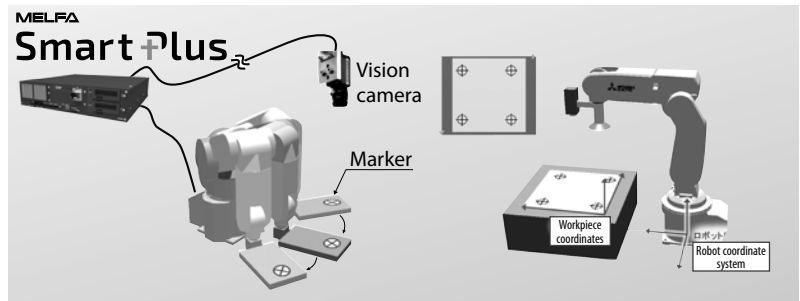

### Coordinate control for additional axes

- Allows synchronized operation when a robot is installed on an additional axis (linear axis) to handle large workpieces which exceed robot's working range
- Allows synchronized operation when tracking of the robot with a workpieces on an additional axis (linear axis) is executed

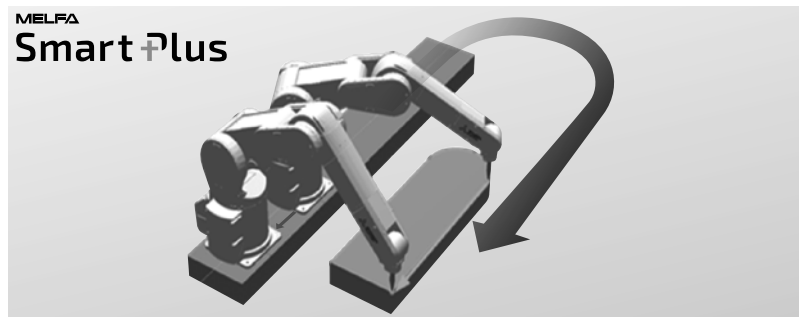

1 Standard high end functions

**Predictive maintenance function**

**Consumption degree calculation function**

- Identify the consumption degree of main components
  - A dynamic model and drive data are used to calculate the physical amount (force, speed, etc.) applied to each part.
  - By comparing this to the lifetime of the components, the consumption degree of each component is calculated. (Reduction gears, ball screws, belts, bearings, grease)
- Notify appropriate maintenance schedules
  - “Warning” and “general-purpose signal output” can be issued when maintenance is required.
- Identification of the appropriate maintenance schedule according to robot operating conditions
- This enables efficient, appropriate maintenance support

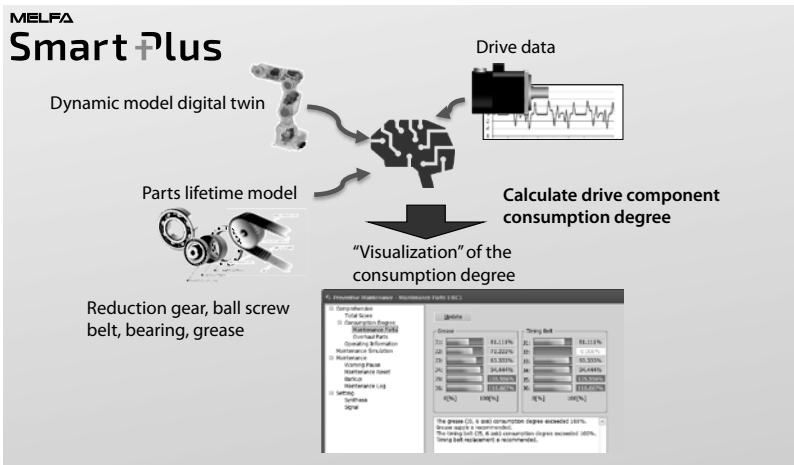

**Abnormality detection function**

- This function detects abnormalities or deterioration of robot reduction gear components early
- Current score of the reduction gear including reduction gears, encoder data abnormality, and encoder communication abnormality
- When the score exceeds the detection level, the reduction gear is assumed to be abnormal and an error (warning) occurs or that effect is notified by the dedicated output signal.
- The current status is displayed as the predictive maintenance message

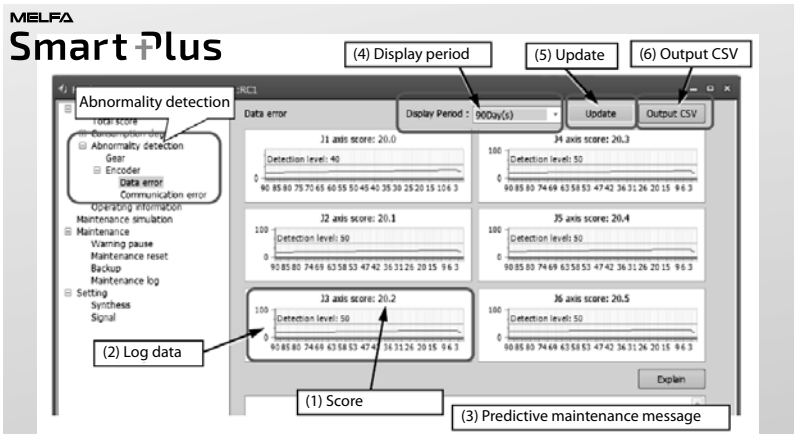

**Maintenance simulation**

- Estimate the maintenance schedule according to operation
  - Estimates the parts replacement time or the recommended maintenance time when a specific motion pattern (robot program) is repeated using simulations on RT ToolBox3
- Support for machine-friendly operation verification
  - By the offline simulation, the robot lifetime can be estimated
  - Operations can be verified by changing the operating program in consideration of tact time and lifetime
- Predict the robot lifetime and annual maintenance cost estimation already during the design stage
- Modify the robot operation to extend the life cycle

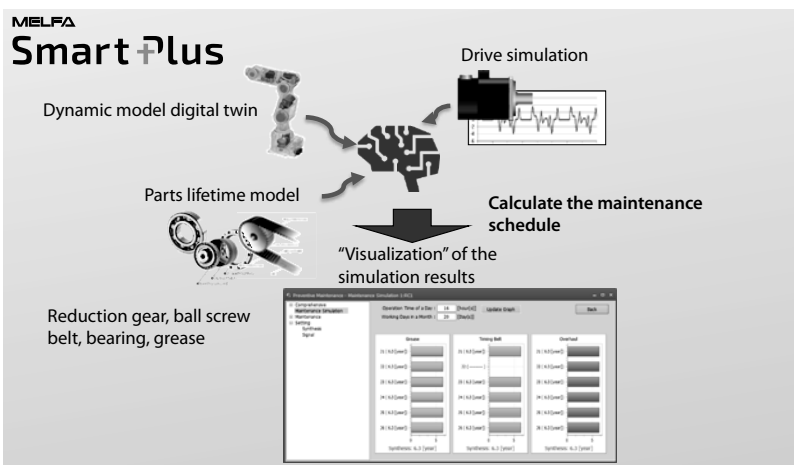

1 Standard high end functions

# Standard high end functions

## Predictive maintenance function

### Integration in a maintenance system

- Support for forming a various maintenance system
  - Interaction with upper-level devices
  - Maintenance information is held as status variables
  - In addition to using maintenance data in the robot program, it is possible to obtain data from upper-level devices via communication middleware.
- Centralized management of robot maintenance data on an upper-level system

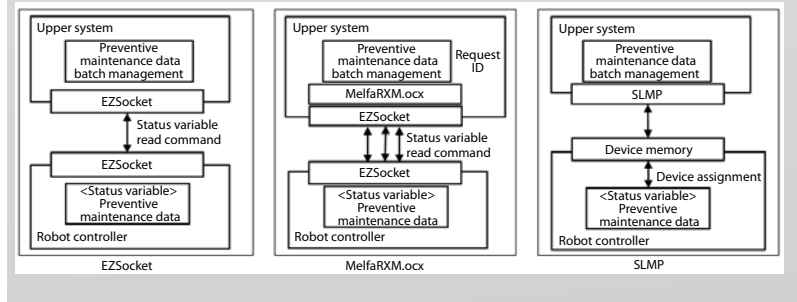
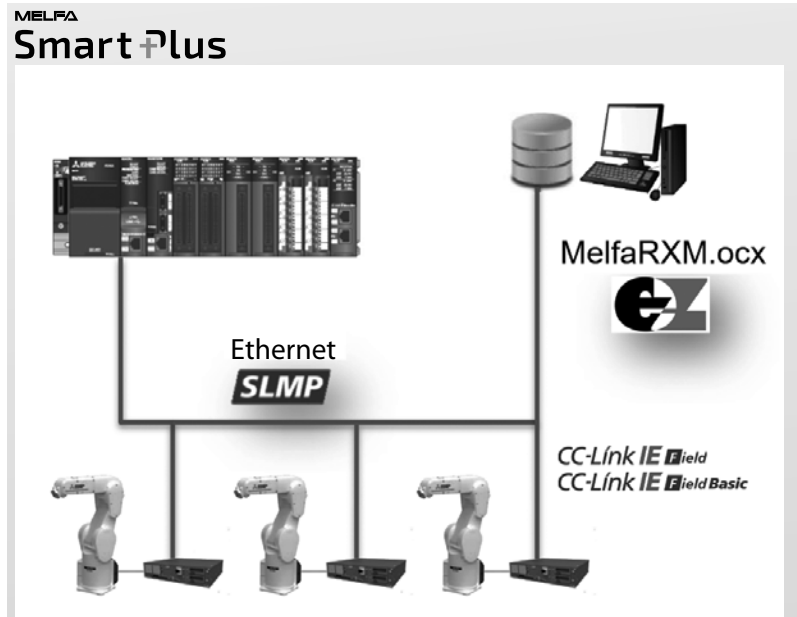

**MELFA SafePlus features**

“MELFA SafePlus” safety technology for the FR series robot controllers

- Supported Safety functions:
  - STO (Safe Torque Off), SS1 (Safe Stop 1), SS2 (Safe Stop 2), SOS (Safe Operation Stop), SLS (Safely-Limited Speed), SLP (Safely-Limited Position)
- All functions follow the safety standards EN ISO 10218-1 (Industrial robots), EN ISO 13849-1 (Safety of machinery), EN 62061/IEC 61508 (Functional safety) and EN 61800-5-2 (Safety function drive).



**Reduced speed control (safe limited speed, SLS)**

Function to control the robot speed with safe limited speed to secure operator’s safety when signaled via safety input signals. Up to four different zones with different limited speed can be activated. Operator can be interactive while the robot is running in automatic mode, but with safe low speed.

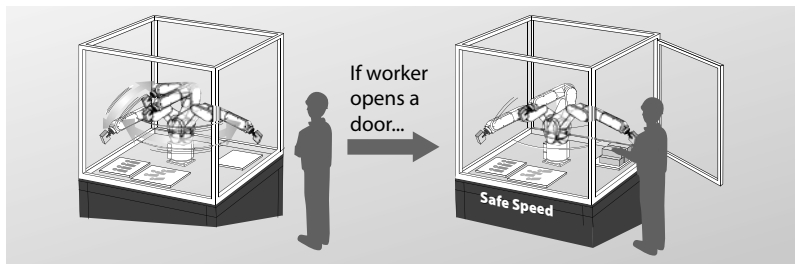

**Limited range control (safe limited position, SLP)**

Function to control the robot movement range and to ensure that the robot does not exceed the set limit activated by the safety input signal. This function monitors the robot arm. If the robot or the attached hand exceeds any set plane, the robot will stop immediately or before it.

Independent areas can be defined for different safety situations.

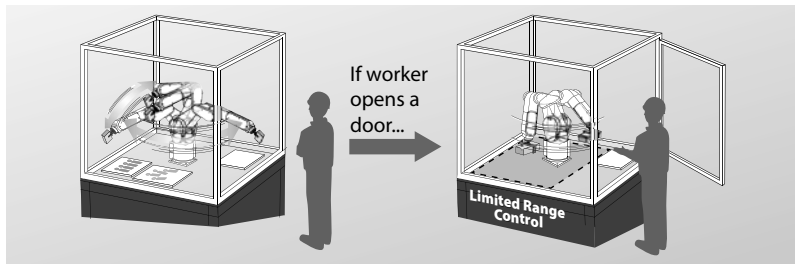

**Safety logic editing**

Expands the dual safety channels to 8 inputs and 4 outputs. Logic for each safe I/O can be edited and in combination with the position monitoring function a safe system can be constructed without using a Safety PLC.

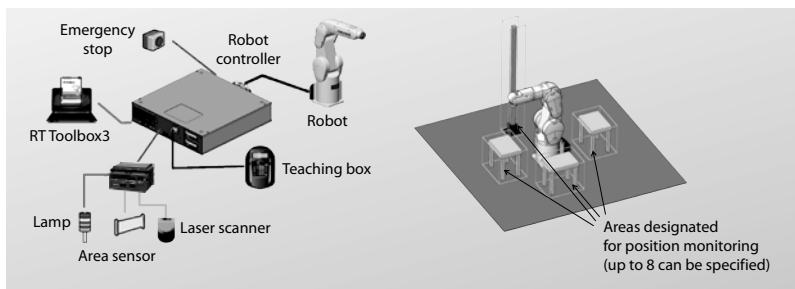

## Special functions with GOT terminals and the iQ Platform

### Shared memory expansion

Enhanced efficiency of monitoring and maintenance operations onsite using a single GOT (display device) as the Human Machine Interface (HMI).

- Enables the robot to be controlled from the GOT even without a teaching box
- Current robot position data, error information, and other items can be displayed easily on the GOT
- Connection with a single Ethernet cable and direct access to the control unit
- 8192 input an output points can be exchanged via Ethernet connection

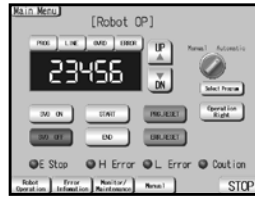

Operation panel screen

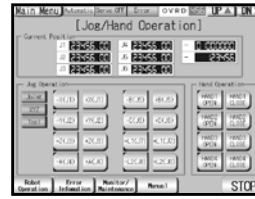

Jog/hand operation screen

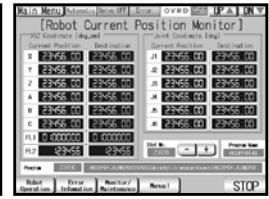

Current position monitor screen

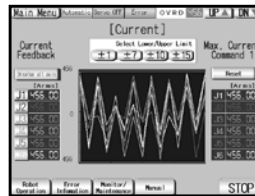

Current value and load factor monitor screen

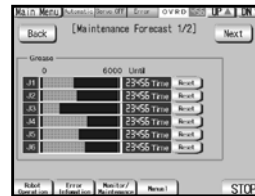

Maintenance forecast screen

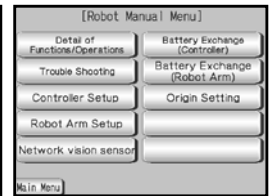

Manual/video display menu

### Direct execution function for programmable controllers

Robots can be controlled easily using programmable controller language.

- Control of system operation using an single programmable controller
- Direct changing of system specifications via programmable controller
- Direct handling of troubleshooting
- Simple movement to taught positions by PLC program
- No need to use any robot programs

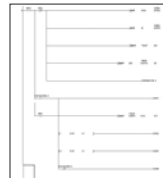

Sequence program

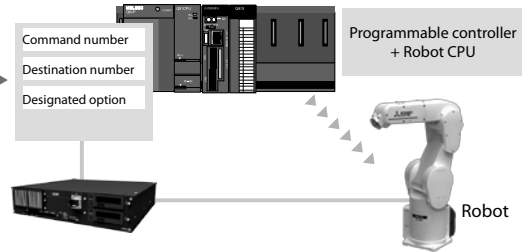

Details	
Operation	Joint-interpolated motion Linear-interpolated motion
Motion control	Designated override Designated acceleration/deceleration settings Designated speed Tool settings Designated auxiliary motion Opening/closing of hand

**Industrial robots RV-2FR(B)/RV-2FRL(B)**



RV-2FR(B)

**The articulated arm robots RV-2FR(B)/RV-2FRL(B)**

The compact and light RV-2FR(B)/RV-2FRL(B) can be seamlessly integrated into different automation systems. Flexibility and the wide range of motion permits acting in applications with limited space, like mounting, assembling, palletising, sorting or bonding. Even the basic model is available with a fully equipped standard controller or as PLC robot with integration onto the iQ Platform.

**Highlights:**

- 2 different arm length with 504 mm and 649 mm
- Only 19/21 kg weight and extremely compact
- Highest flexibility
- Floor, wall and ceiling installation possible
- Position repeatability of  $\pm 0.02$  mm

Characteristics/Functions	Specifications				
	RV-2FR-D/ RV-2FR-R	RV-2FRB-D-S25/ RV-2FRB-R-S25	RV-2FRL-D-S25/ RV-2FRL-R-S25	RV-2FRLB-D-S25/ RV-2FRLB-R-S25	
Degrees of freedom (no. of axes)	6				
Installation posture	Floor, ceiling or wall mounting possible				
Structure	Vertical multiple-joint type				
Drive system	AC servo axes J1, J4, J6: no brake	AC servo (brakes on all axes)	AC servo axes J1, J4, J6: no brake	AC servo (brakes on all axes)	
Position detection method	Absolute encoder				
Payload capacity	rated	2			
	maximum	3			
Arm reachable radius (to the center point of the J5 axis)	504		649		
Operating range	waist (J1)	480 (-240–240)			
	shoulder (J2)	240 (-120–120)		237 (-117–120)	
	elbow (J3)	160 (0–160)			
	wrist twist (J4)	400 (-200–200)			
	wrist pitch (J5)	240 (-120–120)			
	wrist roll (J6)	720 (-360–360)			
Maximum speed	waist (J1)	300		225	
	shoulder (J2)	150		105	
	elbow (J3)	300		165	
	wrist twist (J4)	450		412	
	wrist pitch (J5)	450			
	wrist roll (J6)	720			
Maximum composite speed	4955		4200		
Cycle time (25x300x25 mm with 1 kg load)	0.6		0.7		
Position repeatability	mm $\pm 0.02$				
Ambient temperature	°C 0–40				
Weight	19		21		
Tolerable moment	wrist twist (J4)	4.17			
	wrist pitch (J5)	4.17			
	wrist roll (J6)	2.45			
Tolerable inertia	wrist twist (J4)	0.18 (0.27)			
	wrist pitch (J5)	0.18 (0.27)			
	wrist roll (J6)	0.04 (0.1)			
Tool wiring	Hand input 4 points/hand output 4 points				
Tool pneumatic pipes	$\varnothing$ 4x4 (from the base level to the gripper hand area)				
Supply pneumatic pressure	MPa 0.5 $\pm 10$ %				
Gripper flange	ISO 9409-1-31.5				
Protection rating	IP30				
Robot controller	CR800-D/CR800-R + R16RTCPU				
Order information	Art. no.	313052/ 314029	313053/ 314030	313054/ 314031	313085/ 314032

# Dimensions and movement ranges

## Robot arms RV-2FR(L)(B)

RV-2FR(B)

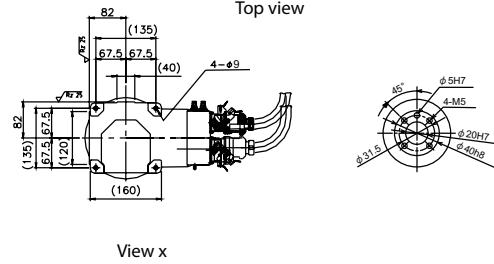
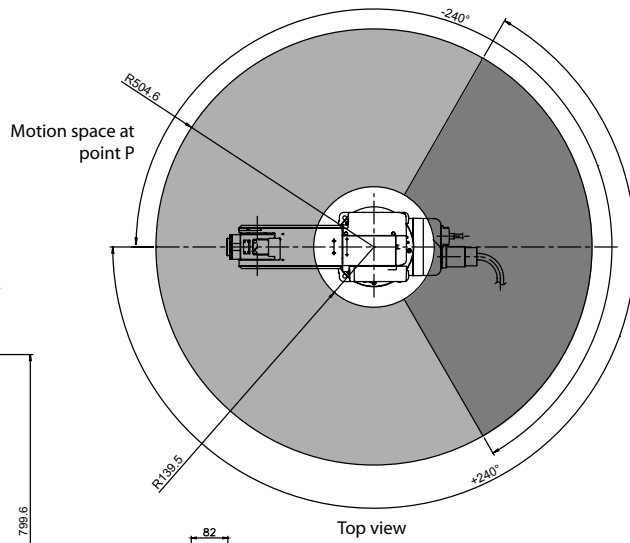
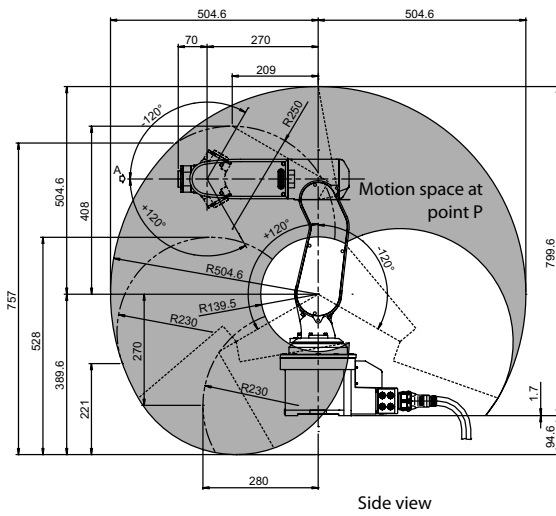

Dimensions: mm

RV-2FRL(B)

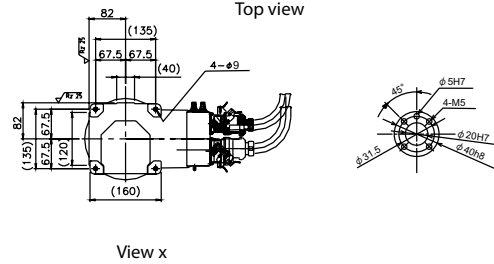
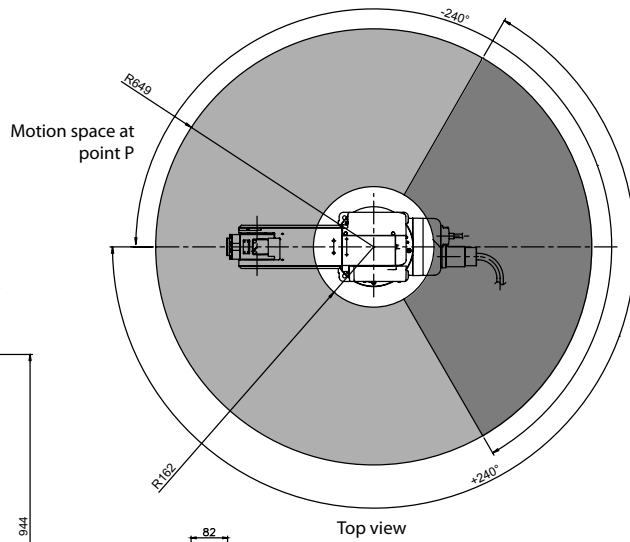
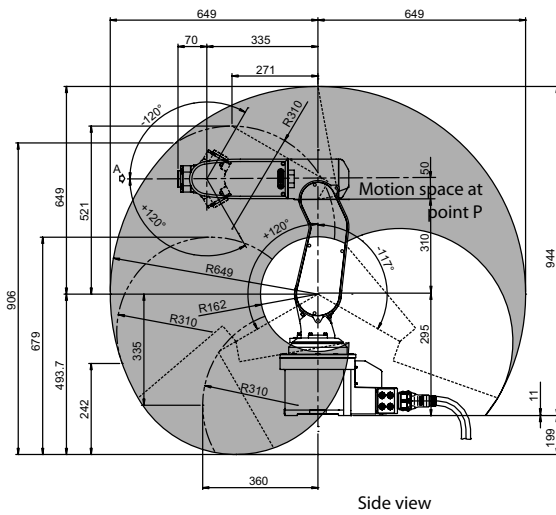

Dimensions: mm



**Industrial robots RV-4FRLM**



RV-4FRLM

**The articulated arm robots RV-4FRLM**

The robots of the RV-4 FR series are designed for easy integration into existing work cells or innovative and compact applications. Features such as the direct control over local I/Os allows the robot to interact directly with sensors and actuators, speeding up and simplifying system building. A new innovative design allows a maximum of flexibility, so that the robot can expand his workspace to work faster and more flexible.

**Highlights:**

- Slim arm design
- IP67 protection
- Internal routed cables and air hoses
- Extended maintenance intervals
- 4 kg rated and maximal payload

Characteristics/Functions		Specifications	
		RV-4FRLM-D	RV-4FRLM-R
Degrees of freedom (no. of axes)		6	
Installation posture		Floor, ceiling or wall mounting possible (wall mounting with limitations in the J1 axis)	
Structure		Vertical multiple-joint type	
Drive system		AC servo (brakes on all axes)	
Position detection method		Absolute encoder	
Payload capacity	maximum	kg	4
Arm reachable radius (to the center point of the J5 axis)		mm	649
Operating range	waist (J1)	degree	480 (±240)
	shoulder (J2)		240 (-120–120)
	elbow (J3)		164 (0–164)
	wrist twist (J4)		400 (±200)
	wrist pitch (J5)		240 (-120–120)
	wrist roll (J6)		720 (±360)
Maximum speed	waist (J1)	degree/s	420
	shoulder (J2)		336
	elbow (J3)		250
	wrist twist (J4)		540
	wrist pitch (J5)		623
	wrist roll (J6)		720
Maximum composite speed		mm/s	9048
Cycle time (25x300x25 mm with 1 kg load)		sec	0.36
Position repeatability		mm	±0.02
Ambient temperature		°C	0–40
Weight		kg	41
Tolerable moment	wrist twist (J4)	Nm	6.66
	wrist pitch (J5)		6.66
	wrist roll (J6)		3.96
Tolerable inertia	wrist twist (J4)	kgm <sup>2</sup>	0.20
	wrist pitch (J5)		0.20
	wrist roll (J6)		0.10
Tool wiring		Hand input 8 points/hand output 8 points	
Tool pneumatic pipes		Ø 6x2 for robot connection (Ø4x8 from base portion to forearm)	
Supply pneumatic pressure		MPa	0.54 (as overpressure if required)
Gripper flange		ISO 9409-1-31.5	
Protection rating		IP67	
Robot controller		CR800-D	CR800-R + R16RTCPU
Order information	IP67 model	Art. no.	313089
	IP40 model		313088
			314056
			314055

Please contact your Mitsubishi Electric representative for ESD, ATEX and cleanroom models.

# Dimensions and movement ranges

## Robot arms RV-4FRLM

RV-4FRL

1 Robots

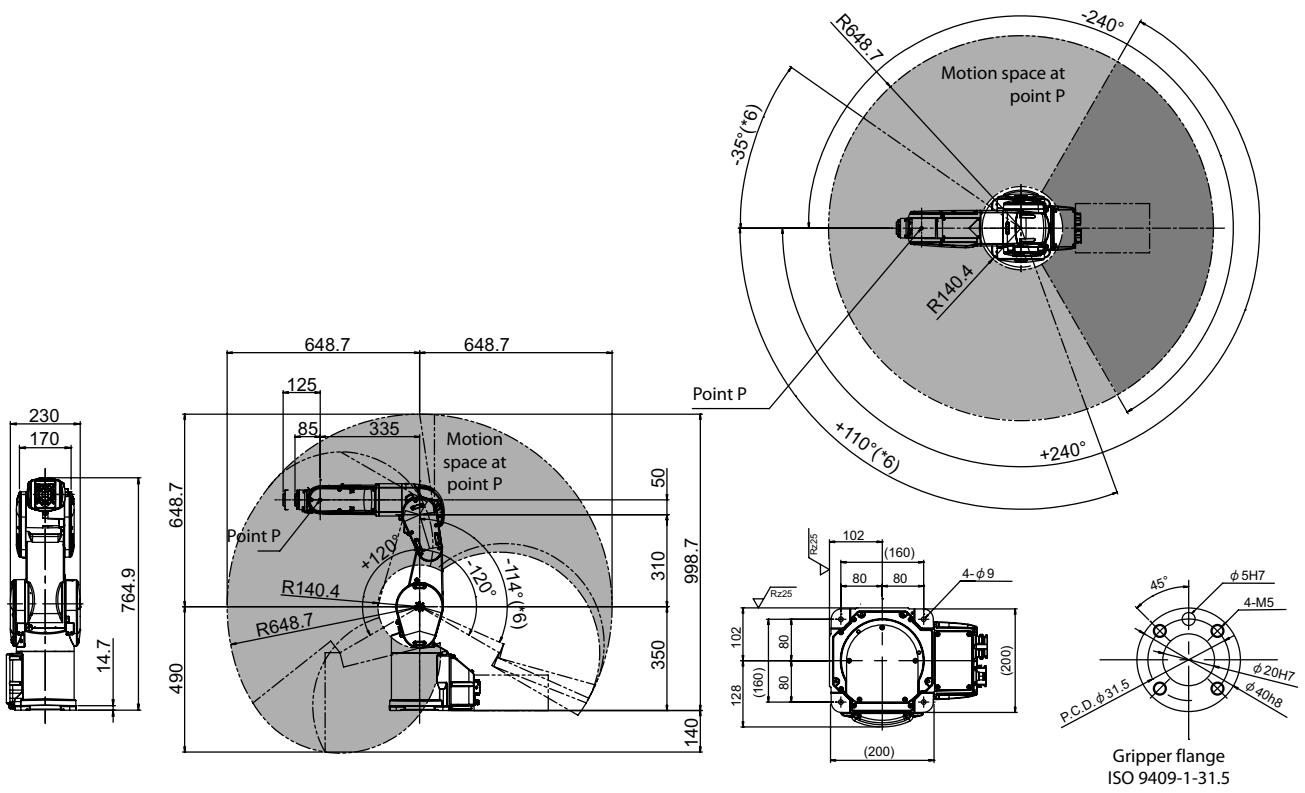

Dimensions: mm

**Industrial robots RV-7FRM/7FRLM/7FRLLM**



RV-7FRLM

**The articulated arm robots RV-7FRM/7FRLM/7FRLLM**

The RV-7FRM with a nominal and maximum payload of 7 kg sets new benchmark standards for speed, flexibility, ease of integration and simplicity of programming. For an optimum work radius the robot is available in three versions with ranges from 713 mm to 1503 mm. Ethernet, USB, tracking, camera connection and additional axis connections are standard in all MELFA Robot Series.

**Highlights:**

- Cycle time of only 0.32 s (RV-7FRM) for a 12-inch cycle
- Drastically increased working range for J1 and J4 axis for a maximum working area
- Internal wiring
- IP67 protection
- Workspace radius of up to 1503 mm (RV-7FRLLM)

Characteristics/Functions		Specifications			
		RV-7FRM-D/ RV-7FRM-R	RV-7FRLM-D/ RV-7FRLM-R	RV-7FRLLM-D RV-7FRLLM-R	
Degrees of freedom (no. of axes)		6			
Installation posture		Floor, ceiling or wall mounting possible (wall mounting with limitations in the J1 axis)			
Structure		Vertical multiple-joint type			
Drive system		AC servo (brakes on all axes)			
Position detection method		Absolute encoder			
Payload capacity		maximum	kg	7	
Arm reachable radius (to the center point of the J5 axis)		mm		713	
Operating range	waist (J1)	degree		480 (±240)	
	shoulder (J2)	degree		240 (-115–125)	
	elbow (J3)	degree		156 (0–156)	
	wrist twist (J4)	degree		400 (±200)	
	wrist pitch (J5)	degree		240 (-120–120)	
	wrist roll (J6)	degree		720 (±360)	
Maximum speed	waist (J1)	degree/s		360	
	shoulder (J2)	degree/s		401	
	elbow (J3)	degree/s		450	
	wrist twist (J4)	degree/s		337	
	wrist pitch (J5)	degree/s		450	
	wrist roll (J6)	degree/s		720	
Maximum composite speed		mm/s		11064	
Cycle time (25x300x25 mm with 1 kg load)		sec		0.32	
Position repeatability		mm		±0.02	
Ambient temperature		°C		0–40	
Weight		kg		65	
Tolerable moment	wrist twist (J4)	Nm		16.2	
	wrist pitch (J5)	Nm		16.2	
	wrist roll (J6)	Nm		6.86	
Tolerable inertia	wrist twist (J4)	kgm <sup>2</sup>		0.45	
	wrist pitch (J5)	kgm <sup>2</sup>		0.45	
	wrist roll (J6)	kgm <sup>2</sup>		0.10	
Tool wiring		Hand input 8 points/hand output 8 points			
Tool pneumatic pipes		Ø 6x2 for robot connection (Ø4x8 from base portion to forearm)			
Supply pneumatic pressure		MPa		0.54 (as overpressure if required)	
Gripper flange		ISO 9409-1-31.5			
Protection rating		IP67			
Robot controller		CR800-D/CR800-R + R16RTCPU			
Order information	IP67 model	Art. no.	313091/ 314058	313093/ 314060	313095/ 314062
	IP40 model		313090/ 314057	313092/ 314059	313094/ 314061

Please contact your Mitsubishi Electric representative for ESD, ATEX and cleanroom models.

# Dimensions and movement ranges

## Robot arms RV-7FRM/7FRLM/7FRLLM

Robots

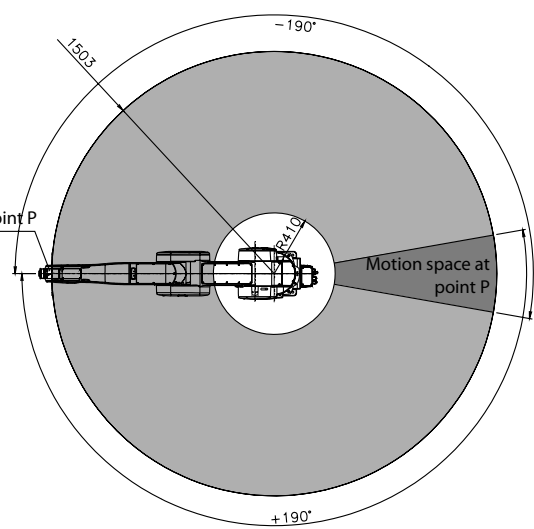
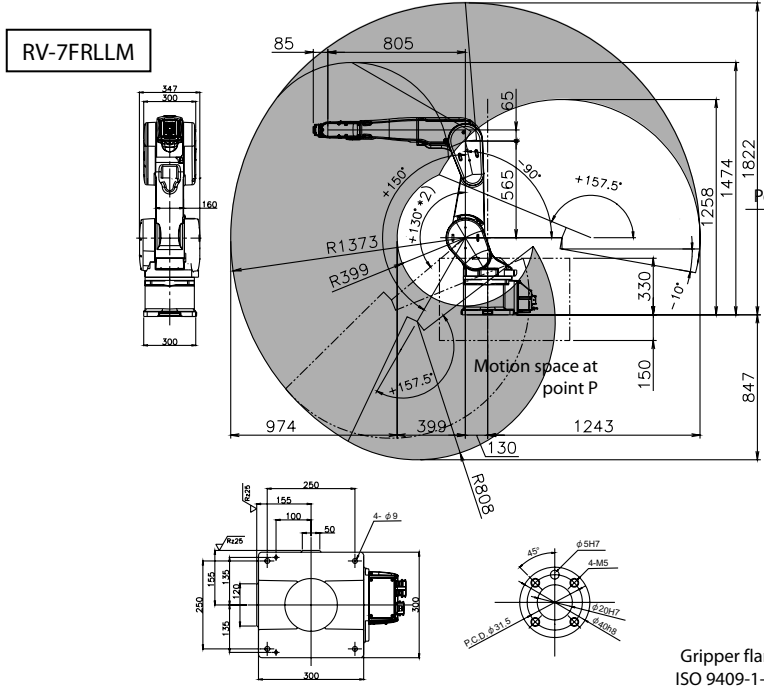
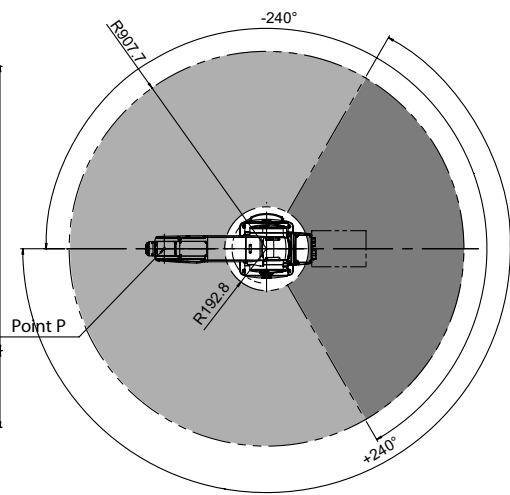
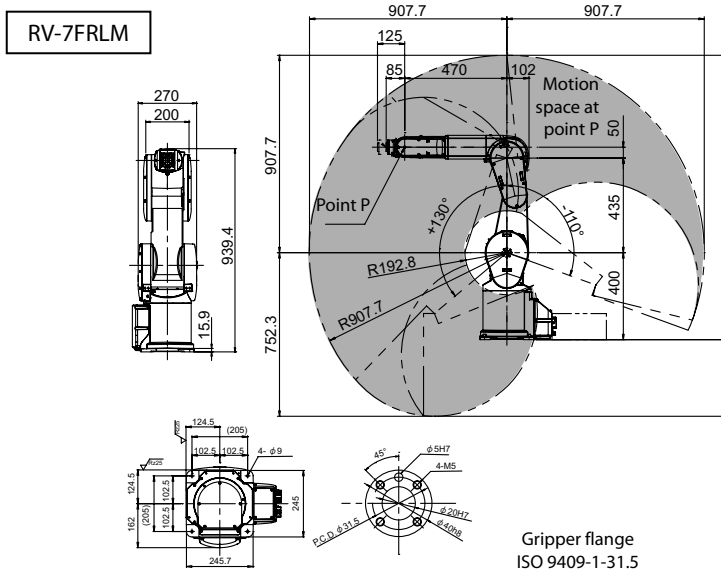
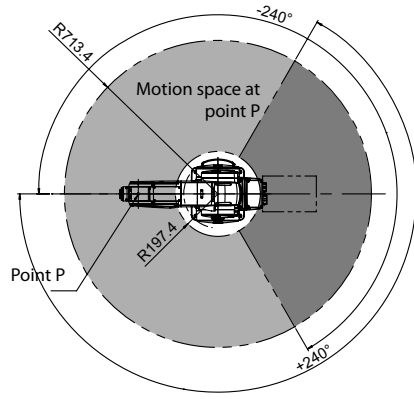
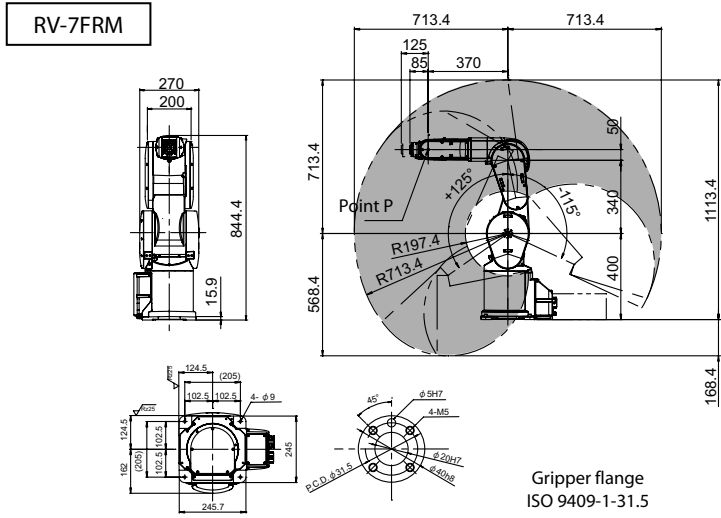

Industrial robots RV-13FRM/RV-13FRLM/RV-20FRM



RV-20FRM

The articulated arm robots RV-13FRM/RV-13FRLM/RV-20FRM

The high-performance robots RV-13 and RV-20 are especially suited for handling heavy loads. Due to the compact body and slim arm design, the robots can operate in a large work area. The anti-collision function of the iQ Platform models prevents collisions between robots which are working closely together.

Highlights:

- internal routing of cables and air hoses through the robot arm
- new gears for quiet, precise positioning and movement
- maximum payload of 20 kg (RV-20FRM)
- Protection rating IP67 standard

Characteristics/Functions	Specifications				
	RV-13FRM-D RV-13FRM-R	RV-13FRLM-D RV-13FRLM-R	RV-20FRM-D RV-20FRM-R		
Degrees of freedom (no. of axes)	6				
Installation posture	Floor, ceiling or wall mounting possible (wall mounting with limitations in the J1 axis)				
Structure	Vertical multiple-joint type				
Drive system	AC servo (all axes with brakes)				
Position detection method	Absolute encoder				
Payload capacity	rated	12	15		
	maximum	13	20		
kg					
Arm reachable radius (to the center point of the J5 axis)	1094	1388	1094		
Operating range	waist (J1)	380(±190)			
	shoulder (J2)	240 (-90–150)			
	elbow (J3)	167.5 (-10–157.5)			
	wrist twist (J4)	400 (±200)			
	wrist pitch (J5)	240 (-120–120)			
	wrist roll (J6)	720 (±360)			
Maximum speed	waist (J1)	290	234		
	shoulder (J2)	234	164		
	elbow (J3)	312	219		
	wrist twist (J4)	375	124		
	wrist pitch (J5)	375	125		
	wrist roll (J6)	720	360		
degree/s					
Maximum composite speed	mm/s	10450	9700		
Cycle time (25x300x25 mm with 1 kg load)	sec	0.53	0.68		
Position repeatability	mm	±0.05			
Ambient temperature	°C	0–40			
Weight	kg	120	130		
Tolerable moment	wrist twist (J4)	19.3	49.0		
	wrist pitch (J5)	19.3	49.0		
	wrist roll (J6)	11			
Tolerable inertia	wrist twist (J4)	0.47	1.40		
	wrist pitch (J5)	0.47	1.40		
	wrist roll (J6)	0.14			
kgm <sup>2</sup>					
Tool wiring	Hand input 8 points/hand output 8 points				
Tool pneumatic pipes	Primary: Ø 6x2, secondary: Ø 6x8				
Supply pneumatic pressure	MPa	0.54 (as overpressure if required)			
Gripper flange	ISO 9409-1-40				
Protection rating	IP67				
Robot controller	CR800-D/CR800-R + R16RTCPU				
Order information	IP67 model	Art. no.	313097/	313099/	312663/
			314064	314066	314068
	IP40 model	Art. no.	313096/	313098/	313100/
			314063	314065	314067

Please contact your Mitsubishi Electric representative for ESD, ATEX and cleanroom models.

# Dimensions and movement ranges

## Robot arms RV-13FRM/RV-13FRLM/RV-20FRM

RV-13FRM/20FRM/13FRLM

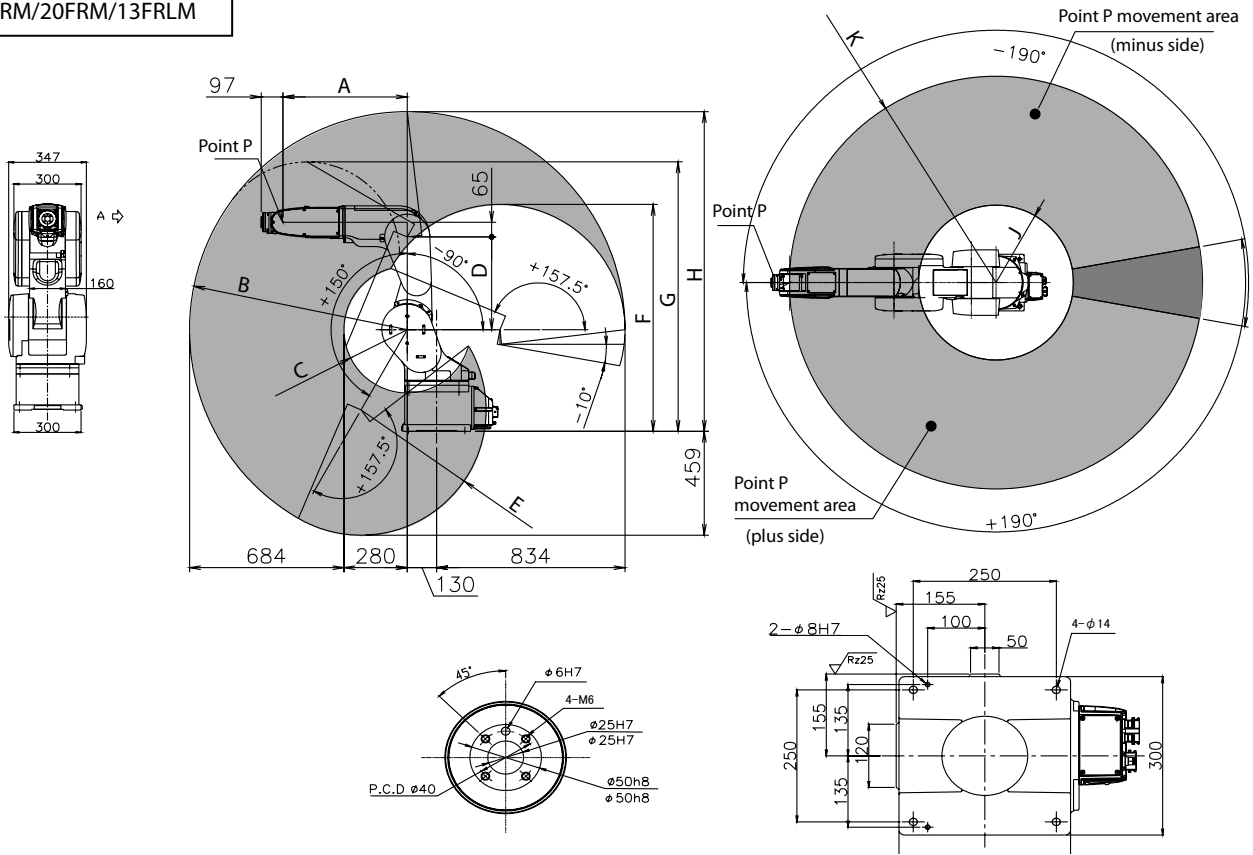

Dimensions: mm

### Variable dimensions

Robot series	A	B	C	D	E	F	G	H	J	K
RV-13FRM/20FRM	550	R964	R280	410	R554	1004	1191	1414	R410	R1094
RV-13FRLM	690	R1258	R328	565	R693	1143	1416	1708	R458	R1388

Industrial robots RV-35F/RV-50F/RV-70F



RV-35F/RV-50F/RV-70F

High capacity robots RV-35F/RV-50F/RV-70F

These robots with payload from 35 kg up to 70 kg are addressing applications that require higher payloads and longer reaches, including CNC machine tending, large material handling, palletizing and end of line packaging.

Highlights:

- Long reach arm up to 2050 mm for tasks can be spread farther apart and can accommodate larger parts and processes
- Multiple environmental protection ratings – available in IP40 and IP67 protection ratings for various application requirements
- Seamless integration in the Mitsubishi Electric automation world

Characteristics/Functions	Specifications		
	RV-35F <sup>①</sup>	RV-50F <sup>①</sup>	RV-70F <sup>①</sup>
Degrees of freedom (no. of axes)	6		
Installation posture	Floor		
Structure	Vertical multiple-joint type		
Drive system	AC servo (all axes with brakes)		
Position detection method	Absolute encoder		
Payload capacity	kg	35	50
Arm reachable radius (to the center point of the J5 axis)	mm	2050	
Operating range	waist (J1)	330 (±165)	
	shoulder (J2)	215 (-80–135)	
	elbow (J3)	261(-90–171)	
	wrist twist (J4)	720 (±360)	
	wrist pitch (J5)	250 (±125)	
	wrist roll (J6)	900 (±450)	
Maximum speed	waist (J1)	185	175
	shoulder (J2)	180	145
	elbow (J3)	190	165
	wrist twist (J4)	305	235
	wrist pitch (J5)	305	235
	wrist roll (J6)	420	350
Maximum composite speed	mm/s	13450	11500
Position repeatability	mm	±0.07	
Ambient temperature	°C	0–40	
Weight	kg	640	
Tolerable moment	wrist twist (J4)	160	300
	wrist pitch (J5)	160	300
	wrist roll (J6)	90	150
Tolerable inertia	wrist twist (J4)	16	30
	wrist pitch (J5)	16	30
	wrist roll (J6)	5	12
Tool wiring	16 input points/16 output points		
Tool pneumatic pipes	Ø 10x2		
Supply pneumatic pressure	MPa	Max. 0.49	
Protection rating	IP67		
Robot controller	CR760 <sup>①</sup>		
<b>Order information</b>	Art. no.	On request	On request

① Please contact your Mitsubishi Electric representative for more details.

# Dimensions and movement ranges

## Robot arms RV-35F/RV-50F/RV-70F

RV-35F/RV-50F/RV-70F

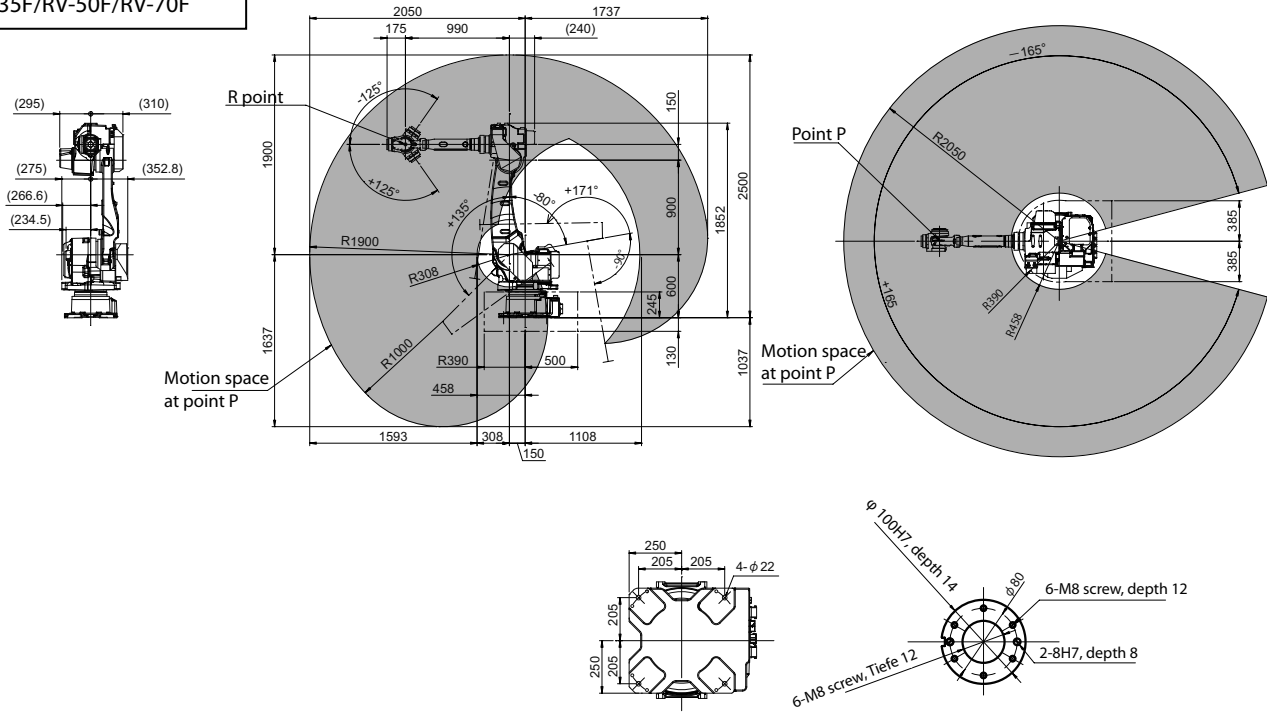

Dimensions: mm



**MELFA ASSISTA collaborative robots RV-5AS-D**



RV-5AS-D

**The collaborative robots RV-5AS-D**

MELFA ASSISTA does not require specialized knowledge or expertise. Advanced safety technology enables humans to collaborate with robots in manufacturing processes and to share workspace.

**Highlights:**

- Simpler and easier
- Easy control
- Easy visual programming
- Easy connecting

Characteristics/Functions	Specifications	
	RV-5AS-D	RV-5AS-D-S01
Degrees of freedom (no. of axes)	6	
Installation posture	Floor and ceiling mounting possible	
Structure	Vertical multiple-joint type	
Drive system	AC servo (brakes on all axes)	
Position detection method	Absolute encoder	
Payload capacity	maximum	kg
Arm reachable radius (to the center point of the J5 axis)	mm	
Operating range	waist (J1)	degree
	shoulder (J2)	degree
	elbow (J3)	degree
	wrist twist (J4)	degree
	wrist pitch (J5)	degree
	wrist roll (J6)	degree
Maximum speed	waist (J1)	degree/s
	shoulder (J2)	degree/s
	elbow (J3)	degree/s
	wrist twist (J4)	degree/s
	wrist pitch (J5)	degree/s
	wrist roll (J6)	degree/s
Maximum composite speed	mm/s	
Position repeatability	mm	
Ambient temperature	°C	
Weight	kg	
Tolerable moment	wrist twist (J4)	Nm
	wrist pitch (J5)	Nm
	wrist roll (J6)	Nm
Tolerable inertia	wrist twist (J4)	kgm <sup>2</sup>
	wrist pitch (J5)	kgm <sup>2</sup>
	wrist roll (J6)	kgm <sup>2</sup>
Tool wiring	Mechanical interface: 2 inputs/4 outputs Forearm: 6 inputs/0 outputs Base: 0 inputs/4 outputs	
Tool pneumatic pipes	Primary: Ø6 × 2, secondary: Ø4 × 4	
Supply pneumatic pressure	MPa	
Gripper flange	ISO 9409-1-40	
Protection rating/environment	IP54/ISO class 5	
Robot controller	CR800-D	
<b>Order information</b>	Art. no.	
	502852	502313

# Dimensions and movement ranges

## Robot arms RV-5AS-D

RV-5AS-D

1 Robots

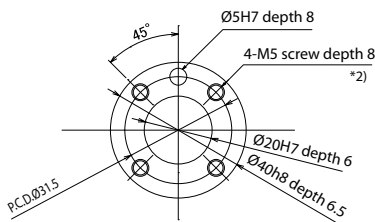
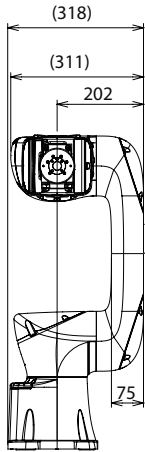

View A: Detail of mechanical interface

\*2) The depth in which the screw is tightened is 7.5 to 8 mm.

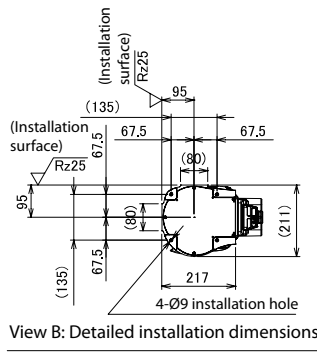

View B: Detailed installation dimensions

The following figure shows a robot at the position of:  
 $J1=0^\circ, J2=0^\circ, J3=90^\circ, J4=0^\circ, J5=0^\circ, \text{ and } J6=0^\circ$

Upper view

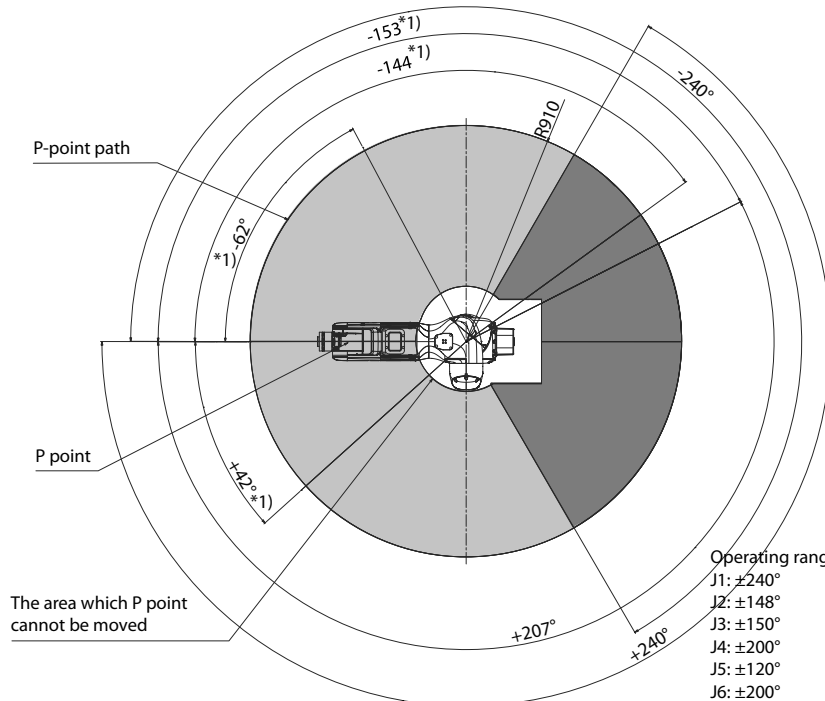

The area which P point cannot be moved

Operating range for each axis:  
 J1:  $\pm 240^\circ$   
 J2:  $\pm 148^\circ$   
 J3:  $\pm 150^\circ$   
 J4:  $\pm 200^\circ$   
 J5:  $\pm 120^\circ$   
 J6:  $\pm 200^\circ$

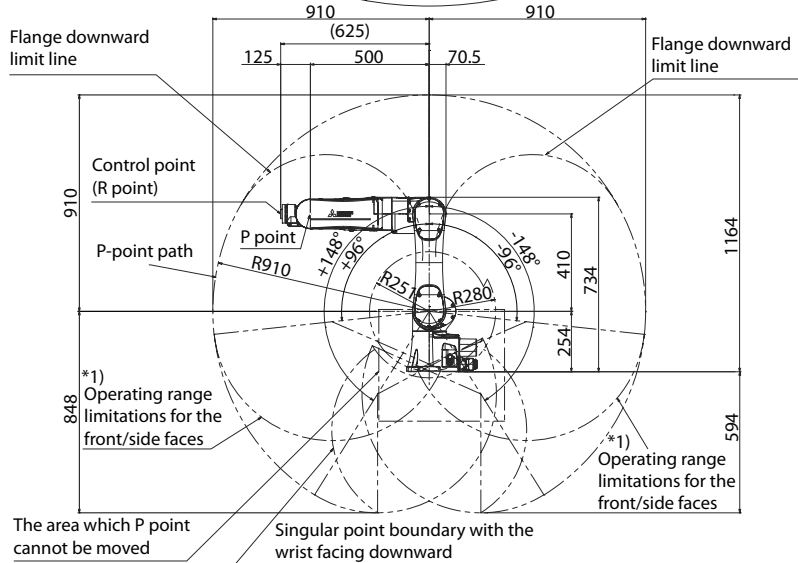

\*1) Limits of the front operating range:  
 If the angle of J1 is  $-62^\circ \leq J1 \leq +207^\circ$  or  $J1 \leq -153^\circ$ , then J2 is limited to  $-96^\circ \leq J2$ .  
 If the angle of J1 is  $+42^\circ \leq J1$  or  $J1 \leq -144^\circ$ , then J2 is limited to  $J2 \leq +96^\circ$ .  
 If the angle of J2 is  $J2 \leq -95^\circ$ , then J3 is limited to  $J3 \leq +146^\circ$ .  
 If the angle of J2 is  $J2 \leq +30^\circ$ , then J3 is limited to  $-146^\circ \leq J3$ .

Dimensions: mm

**Industrial robot RV-8CRL**



RV-8CRL

**The articulated arm robot RV-8CRL**

In addition to a slim, compact exterior and small robot base, its structure features minimal protrusions to the front, back, and sides, resulting in reduced interference with surroundings when the robot operates. This makes it suited to integration with automation cells and manufacturing equipment.

**Highlights:**

- Compact and functional design
- Expanded effective working area
- Beltless coaxial drive mechanism
- User wiring/piping built into arm
- No backup battery
- IP65 protection
- I/O option card 2D-TZ378 with 32 inputs/32 outputs is included

Characteristics/Functions		Specifications	
		RV-8CRL-D-S15	
Degrees of freedom (no. of axes)		6	
Installation posture		Floor, ceiling or wall mounting possible (wall mounting with limitations in the J1 axis)	
Structure		Vertical multiple-joint type	
Drive system		AC servo (brakes on all axes)	
Position detection method		Absolute encoder	
Payload capacity	maximum	kg	8
Arm reachable radius (to the center point of the J5 axis)		mm	931
Operating range	waist (J1)	degree	±170
	shoulder (J2)		±110
	elbow (J3)		0–165
	wrist twist (J4)		±200
	wrist pitch (J5)		±120
	wrist roll (J6)		±360
Maximum speed	waist (J1)	degree/s	288
	shoulder (J2)		321
	elbow (J3)		360
	wrist twist (J4)		337
	wrist pitch (J5)		450
	wrist roll (J6)		720
Maximum composite speed		mm/s	10500
Cycle time (25x300x25 mm with 1 kg load)		sec	0.44
Position repeatability		mm	±0.02
Ambient temperature		°C	0–40
Weight		kg	41
Tolerable moment	wrist twist (J4)	Nm	16.2
	wrist pitch (J5)		16.2
	wrist roll (J6)		6.86
Tolerable inertia	wrist twist (J4)	kgm <sup>2</sup>	0.45
	wrist pitch (J5)		0.45
	wrist roll (J6)		0.10
Tool wiring		15-pins, D-sub	
Tool pneumatic pipes		Ø 6x2	
Supply pneumatic pressure		MPa	0.54
Gripper flange		ISO 9409-1-40	
Protection rating		IP65	
Robot controller		CR800-D	
<b>Order information</b>		Art. no.	492799

# Dimensions and movement ranges

## Robot arms RV-8CRL

RV-8CRL

1 Robots

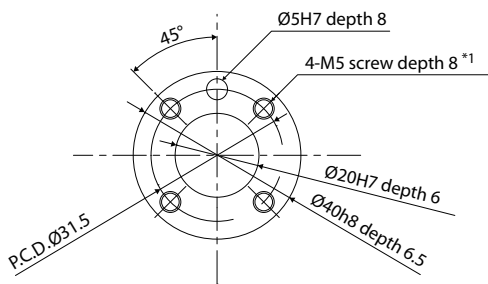
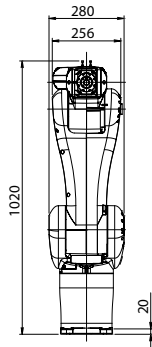

View A: Detail of mechanical interface

\*1) The depth in which the screw is tightened is 7.5 to 8 mm.

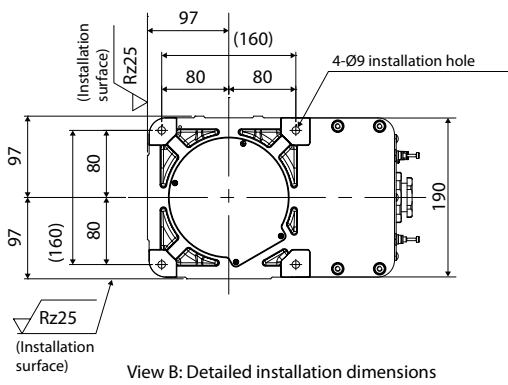

View B: Detailed installation dimensions

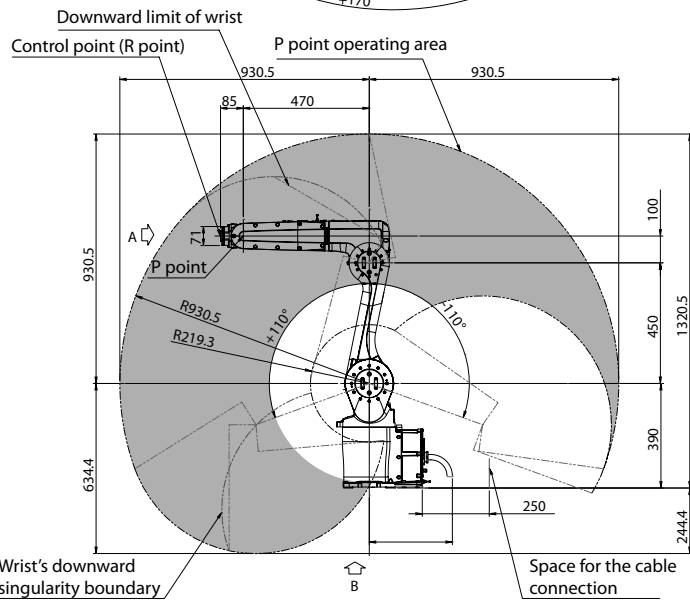
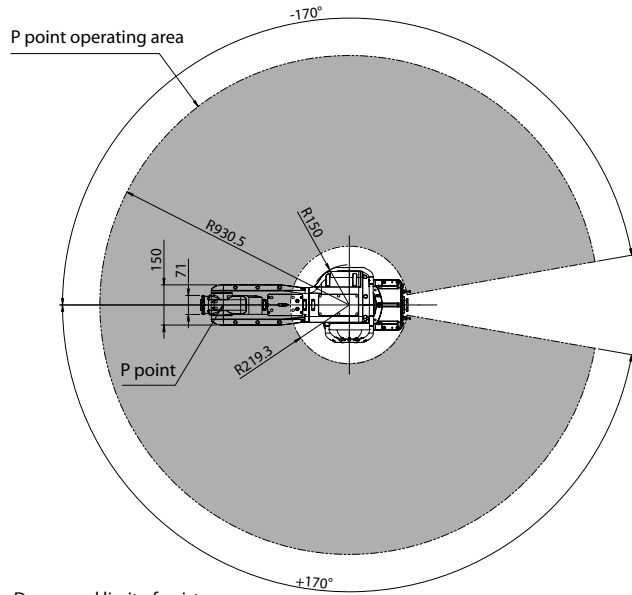

Dimensions: mm

**Industrial robots RH-1FRHR**



**SCARA robot for overhead installation**

With its special compact design and support for overhead installation above the application, the robot RH-1FRHR doesn't take up any valuable space in the work area next to the installation location, enabling even smaller work cell dimensions.

The RH-1FRHR5515 is a high-speed robot dedicated for the handling of small parts up to 1 kg. Up to 150 picks/min with conveyor tracking including hand open/close are possible.

**Highlights:**

- High-speed 4 axis robots for fastest pick and place (cycle times of only 0.28 s)
- Up to 150 picks/min. with conveyor tracking including hand open/close
- Space saving and flexible installation method
- Optionally integrated vacuum valve and bellow for highest requirements in pharmaceutical and F&B application

Characteristics/Functions		Specifications		
		RH-1FRHR5515-D	RH-1FRHR5515-R	
Degrees of freedom (no. of axes)		4		
Installation posture		On floor, ceiling mounting, wall mounting		
Structure		Horizontal articulated arm (SCARA)		
Drive system		AC servo		
Position detection method		Absolute encoder		
Brake attachment		Axes J1, J2, J4: no brake; axis J3: with brake		
Payload capacity	rated	kg	1	
	maximum		3	
Maximum reach		mm	550	
Operating range	J1	degree	±177	
	J2	degree	±145	
	J3 (Z)	mm	150	
	J4 (θ axis)	degree	±360	
Maximum speed	J1	degree/s	337.5	
	J2	degree/s	720	
	J3 (Z)	mm/s	765	
	J4 (θ axis)	degree/s	3000	
Maximum composite speed		mm/s	6267	
Cycle time (25x300x25 mm with 1 kg load)		sec	0.28	
Allowable wrist moment of inertia	rated	kgm <sup>2</sup>	0.005	
	maximum		0.005	
Position repeatability	X, Y direction		mm	±0.012
	J3 (Z direction)		mm	±0.01
	J4 (θ axis)		degree	±0.004
Ambient temperature		°C	0–40	
Weight		kg	49	
Tool wiring		Hand: 8 inputs/8 outputs, 8 signal cables		
Tool pneumatic pipes		Primary: Ø 6x2 (secondary: Ø 4x8 by option)		
Supply pneumatic pressure		MPa	5 ±10 % for the pneumatic gripper	
Protection rating		IP20 (IP65/ISO class 5 with additional bellow)		
Robot controller		CR800-D	CR800-R + R16RTCPU	
<b>Order information</b>		Art. no.	312997	313661

# Dimensions and movement ranges

## Robot arms RH-1FRHR

RH-1FRHR

1 Robots

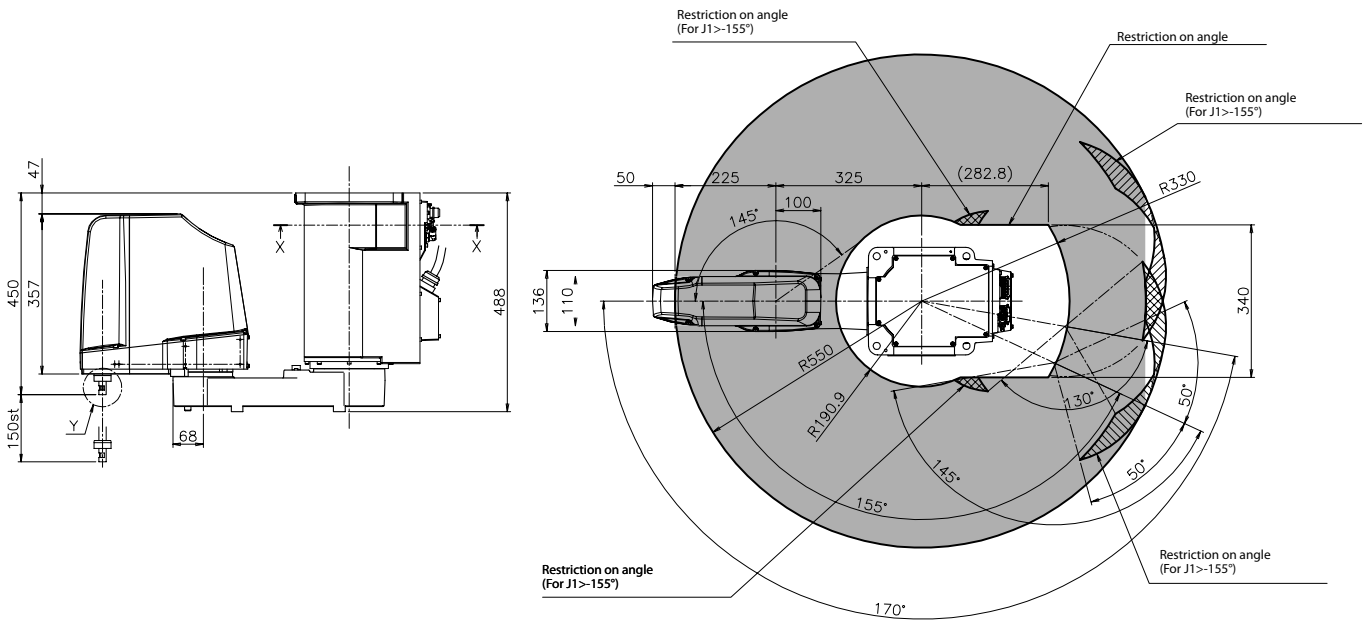

Dimensions: mm

Industrial robots RH-3FRHR



RH-3FRHR

The SCARA robots RH-3FRHR

With its special compact design and support for overhead installation above the application, the robot RH-3FRHR doesn't take up any valuable space in the work area next to the installation location, enabling even smaller work cell dimensions. The robot's perfectly circular cylindrical workspace is 150 mm high with a diameter of 700 mm. It can access any point in this space with a repeatability of just  $\pm 0.01$  mm while manipulating a payload of up to 3 kg.

Highlights:

- Overhead installation for minimum space requirements
- Only 24 kg weight
- Cycle times of only 0.32 s
- High stability due to compact design
- Pneumatic hoses and signal wires are routed inside the robot

Characteristics/Functions		Specifications	
		RH-3FRHR3515-D-S25	RH-3FRHR3515-R-S25
Degrees of freedom (no. of axes)		4	
Installation posture		Overhead	
Structure		Horizontal multiple-joint type	
Drive system		AC servo	
Position detection method		Absolute encoder	
Brake attachment		Axes J1, J2, J4: no brake; axis J3: with brake	
Payload capacity	rated	kg	1
	maximum		3
Maximum reach	arm 1 + arm 2		mm
	350		
Operating range	J1	degree	450 ( $\pm 225$ )
	J2	degree	450 ( $\pm 225$ )
	J3 (Z)	mm	150
	J4 ( $\theta$ axis)	degree	1440 ( $\pm 720$ )
Maximum speed	J1	degree/s	672
	J2	degree/s	708
	J3 (Z)	mm/s	1500
	J4 ( $\theta$ axis)	degree/s	3146
Maximum composite speed		mm/s	6267 (J1, J2)
Cycle time (25x300x25 mm with 1 kg load)		sec	0.32
Allowable wrist moment of inertia	rated	kgm <sup>2</sup>	0.005
	maximum		0.05
Position repeatability	X, Y direction		mm
	$\pm 0.01$		
	J3 (Z direction)	mm	$\pm 0.01$
		J4 ( $\theta$ axis)	degree
		$\pm 0.01$	
Ambient temperature		°C	0–40
Weight		kg	24
Tool wiring		Input 8 points/output 8 points (option: output 8 points), 8 spare wires	
Tool pneumatic pipes		Primary: $\varnothing$ 6x2 (secondary: $\varnothing$ 4x8 by option)	
Supply pneumatic pressure		MPa	5 $\pm$ 10 % for the pneumatic gripper
Protection rating		IP20	
Robot controller		CR800-D	CR800-R + R16RTCPU
Order information		Art. no.	
		312998	314028

Please contact your Mitsubishi Electric representative for IP65 and cleanroom models.

# Dimensions and movement ranges

## Robot arms RH-3FRHR

RH-3FRHR

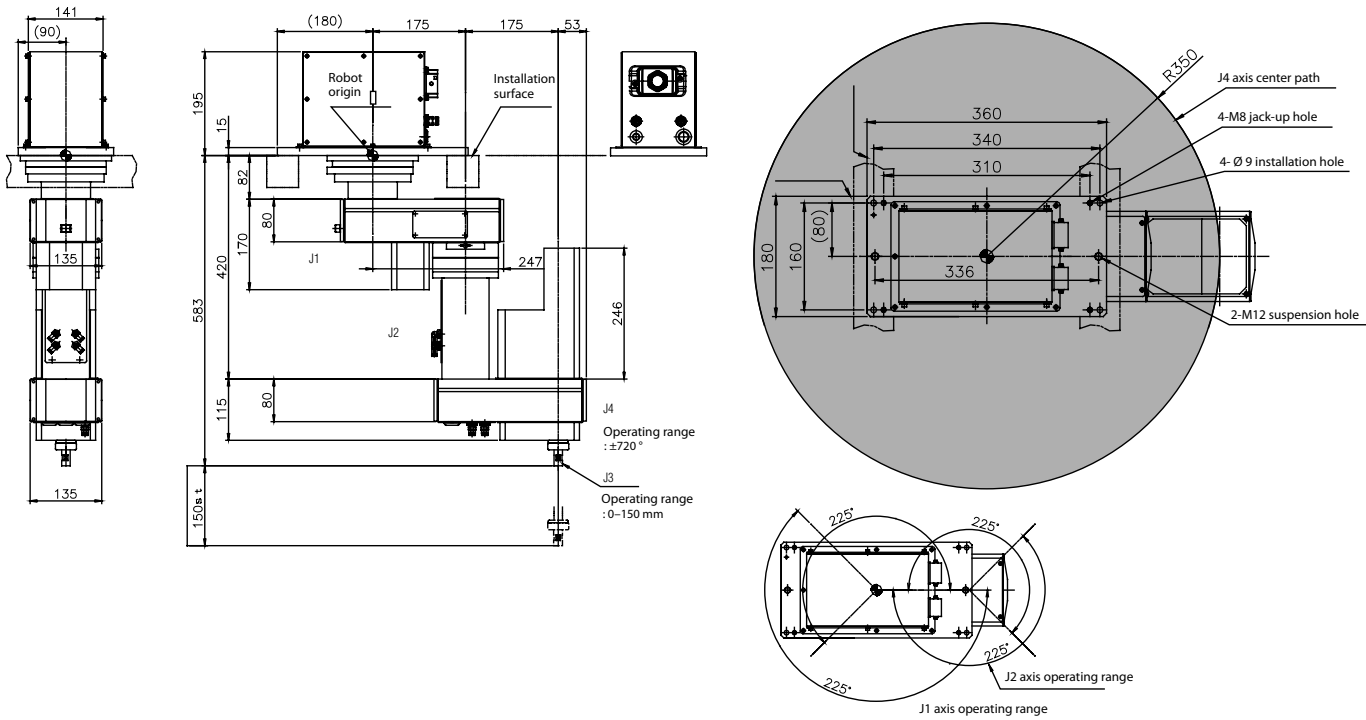

Dimensions: mm



**Industrial robots RH-FRH**



**The SCARA robots RH-FRH**

SCARA robots are ideal for sorting, palletizing and component installation due to their short cycle time. The robots of the RH-FR series achieve the highest speeds in their class thanks to the new motors developed by Mitsubishi Electric, high arm rigidity, and unique control technology.

The resulting reduced cycle time of only 0.29 seconds for a 12" cycle make for significantly increased productivity and improved continuous operation.

**Highlights:**

- Connections for pneumatic grippers, Ethernet, USB, tracking functions, camera interface, hand I/O, additional axis controller and an interface for GOT HMI's
- Fully enclosed cabling to end of spindle for protection and safety
- RH-6/12/20FRH has the tried-and-tested protection class IP54 (IP65 optional)

Characteristics/Functions		Specifications				
		RH-3FRH5515-D/ RH-3FRH5515-R	RH-6FRH5520N-D/ RH-6FRH5520N-R	RH-12FRH8535N-D/ RH-12FRH8535N-R	RH-20FRH10035N-D/ RH-20FRH10035N-R	
Degrees of freedom (no. of axes)		4				
Installation posture		Floor mounting				
Structure		Horizontal multiple-joint type				
Drive system		AC servo				
Position detection method		Absolute encoder				
Brake attachment		Axes J1, J2, J4: no brake; axis J3: with brake				
Payload capacity	rated	1	3		5	
	maximum	3	6	12	20	
Maximum reach	arm 1 + arm 2	550		850	1000	
		mm				
Operating range	J1	340 (±170)				
	J2	290 (±145)		306 (±153)		
	J3 (Z)	150	200	350		
	J4 (θ axis)	720 (±360)				
Maximum speed	J1	400		280		
	J2	720	670	450		
	J3 (Z)	1100	2400	2800	2400	
	J4 (θ axis)	3000	2500	2400	1700	
Maximum composite speed		8300		11350	13283	
Cycle time (25x300x25 mm with max. 2 kg load)		0.51	0.29	0.30	0.36	
Allowable wrist moment of inertia	rated	0.005	0.01	0.025	0.065	
	maximum	0.06	0.12	0.3	1.05	
Position repeatability	X, Y direction	±0.012		±0.015		
	J3 (Z direction)	±0.010				
	J4 (θ axis)	±0.004		±0.005		
Ambient temperature		°C 0–40				
Weight		32	37	69	77	
Tool wiring		Input 8 points/output 8 points (total 20 scores)				
Tool pneumatic pipes		Primary: Ø 6x2, secondary: Ø 4x8				
Supply pneumatic pressure		MPa 5 ±10 % for the pneumatic gripper				
Protection rating		IP20	IP54 (IP65 with additional bellow)			
Robot controller		CR800-D/CR800-R + R16RTCPU				
<b>Order information</b>		Art. no.	312930/ 313651	312985/ 313666	312991/ 313672	312995/ 313676

Please contact your Mitsubishi Electric representative for ESD and cleanroom models.

# Dimensions and movement ranges

## Robot arms RH-FRH

### RH-3FRH

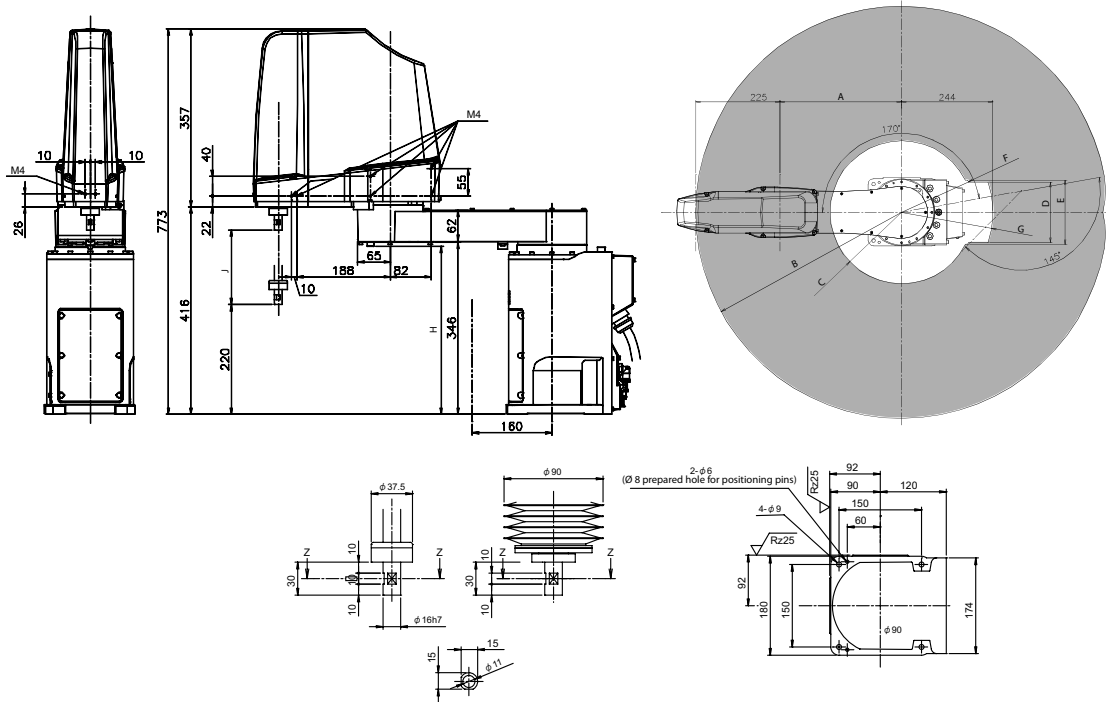

Dimensions: mm

### Variable dimensions

Robot series	A	B	C	D	E	F	G	H	J
RH-3FRH515	125	R550	R142	210	R253	220	R174	342	150

### RH-6FRH

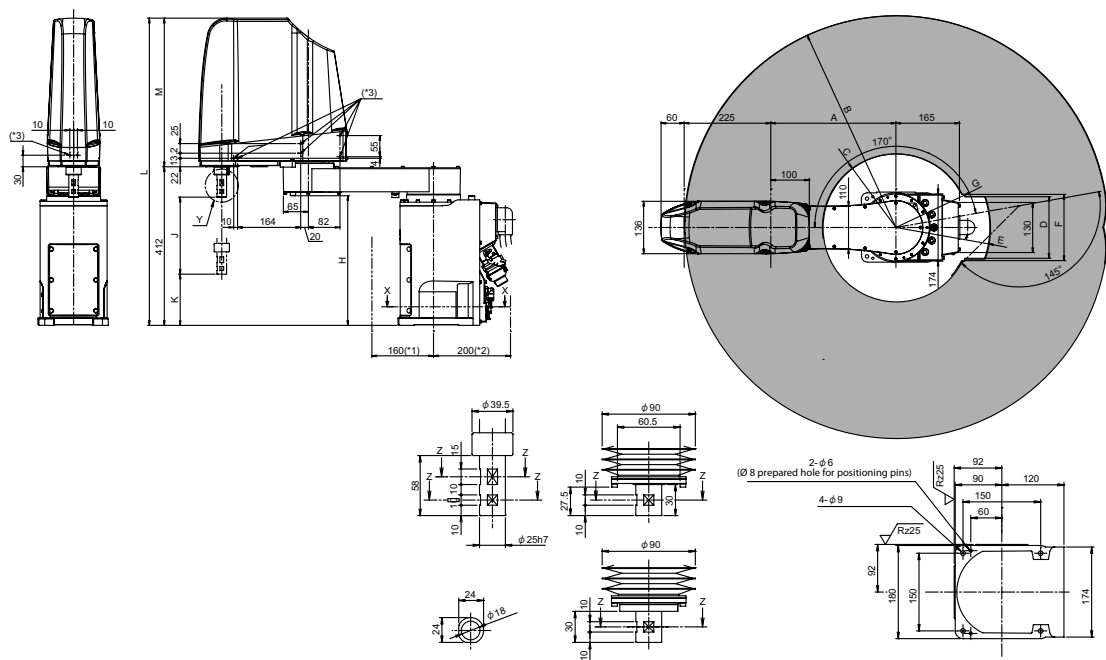

Dimensions: mm

### Variable dimensions

Robot series	A	B	C	D	E	F	G	H	J	K	L	M
RH-6FRH520	325	R550	R191	160	R244	172	R197	337	200	133	798	386



## Industrial robots RH-CRH



RH-3CRH

### The SCARA robots RH-CRH

These robots expand the Mitsubishi Electric SCARA robot product portfolio and are perfect for pick & place, assembly and conveyor tracking applications where a cost-efficient solution is required. Thanks to their compact design and large working area, the RH-CRH robots are suitable for a wide range of applications.

#### Highlights:

- Compact arm for space saving
- Lightweight robot arms
- High-speed operation and high performance for productivity
- Excellent cost performance
- MELFA SafePlus option supports safety monitoring functions and can directly handle the safety logic in the robot controller without using a safety PLC
- I/O option card 2D-TZ378 with 32 inputs/32 outputs is included

Characteristics/Functions	Specifications		
	RH-3CRH4018-D-S15	RH-6CRH6020-D-S15	RH-6CRH7020-D-S15
Degrees of freedom (no. of axes)	4		
Installation posture	Floor mounting		
Structure	Horizontal multiple-joint type		
Drive system	AC servo		
Position detection method	Absolute encoder		
Brake attachment	Axes J1, J2: no brake; axes J3, J4: with brake		
Payload capacity	rated	1	2
	maximum	3	6
Maximum reach	mm	400	700
Operating range	J1	264 (±132)	
	J2	282 (±141)	300 (±150)
	J3 (Z)	180	200
	J4 (θ axis)	720 (±360)	
Maximum speed	J1	720	420
	J2	720	
	J3	1100	
	J4	2600	2500
	J1+J2	7200	7800
Cycle time (25x300x25 mm with 1 kg load)	sec	0.44	0.43
Allowable wrist moment of inertia	rated	0.005	0.01
	maximum	0.05 (0.075)	0.12 (0.18)
Position repeatability	X, Y direction	±0.01	±0.02
	J3 (Z direction)	±0.01	
	J4 (θ axis)	±0.01	
Ambient temperature	°C	0–40	
Weight	kg	14	17
Tool wiring		15-pins, D-sub	
Tool pneumatic pipes		∅ 6x2, ∅ 4x1	
Supply pneumatic pressure	MPa	0.5 ±10 %	
Protection rating		IP20	
Robot controller		CR800-CHD	
<b>Order information</b>	Art. no.	500837	500838
			500839



## Industrial robots RD-1F500/RD-1F800/RD-1F1100/RD-1F1300



RD-1F800

### Delta robots

When items to be picked and placed for packing and assembly are relatively lightweight with simple geometries, then delta robots can offer an effective and reliable high quality, high-speed solution. Users can take the advantage of Mitsubishi Electric's highly dynamic servo technology to drive the parallel kinematic axis, and control via Mitsubishi Electric's standard robot controller.

### Highlights:

- Lightweight and simple construction for high-speed pick-and-place applications.
- Seamless integration in Mitsubishi Electric robot controller
- Fully integrated in RT Toolbox3 inclusive simulation
- Dedicated HD models with IP69K and stainless steel for F&B industry

Characteristics/Functions	Specifications			
	RD-1F500 <sup>①</sup>	RD-1F800 <sup>①</sup>	RD-1F1100 <sup>①</sup>	RD-1F1300 <sup>①</sup>
Degrees of freedom (no. of axes)	4			
Installation posture	Ceiling mounting			
Structure	Delta kinematic			
Drive system	AC servo motor (J1/J2/J3: with brake; rotation axis: without brake)			
Position detection method	Absolute encoder			
Payload capacity	rated	1		
	maximum	2	3	
Maximum reach	mm	Ø 500x130	Ø 800x250	Ø 1100x250 Ø 1300x250
Cycle time (25x300x25 mm with max. 1 kg load)	sec	Max. 200		Max. 180 Max. 150
Position repeatability	X, Y direction	mm	±0.2	±0.1 ±0.2
	J3 (Z direction)	mm	±0.3	
Ambient temperature	°C	5–45		
Weight	kg	45	80	85
Protection rating		IP65		
Robot controller		CR750 <sup>①</sup>		
<b>Order information</b>	Art. no.	On request		

<sup>①</sup> Please contact your Mitsubishi Electric representative for more details.

FR-D series system configuration

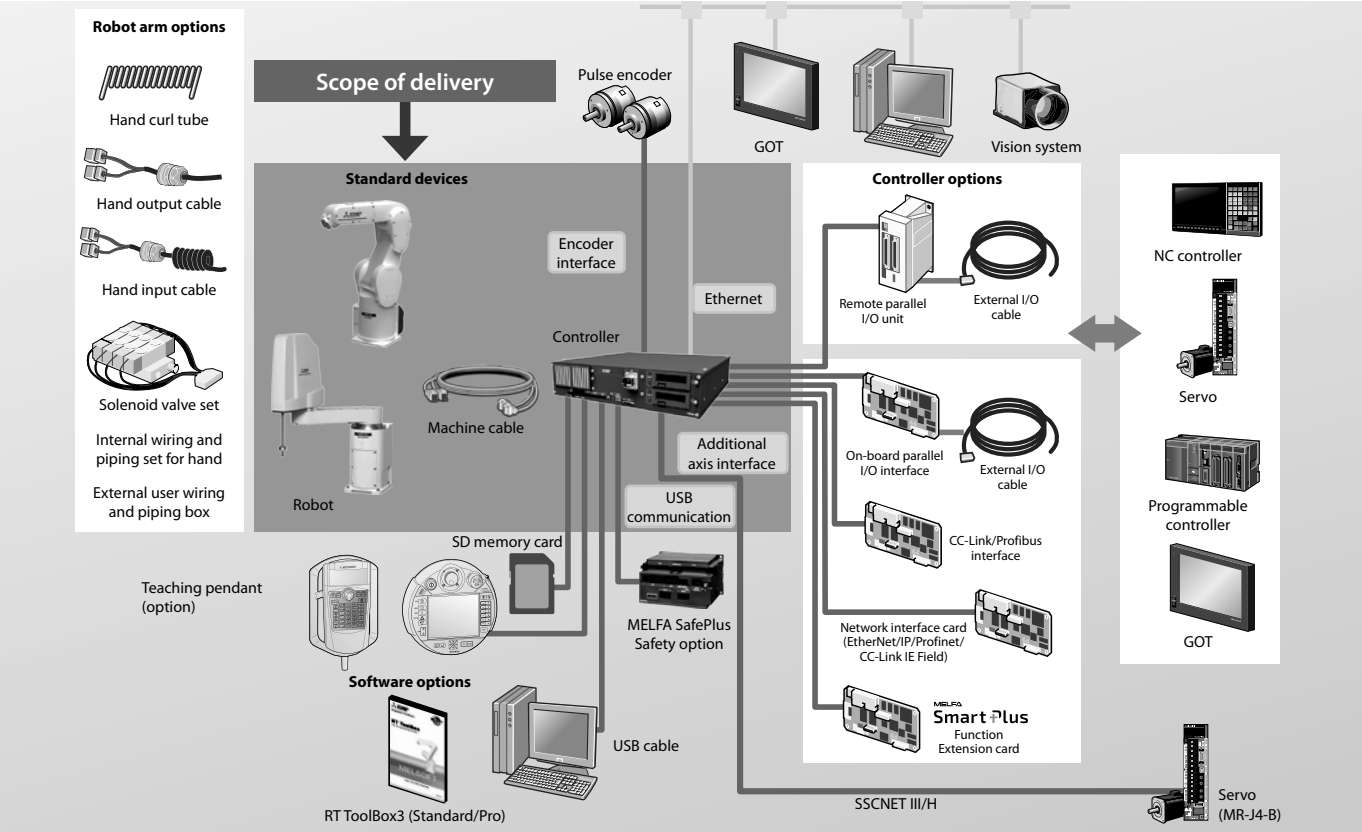

FR-R series system configuration (iQ-R Platform)

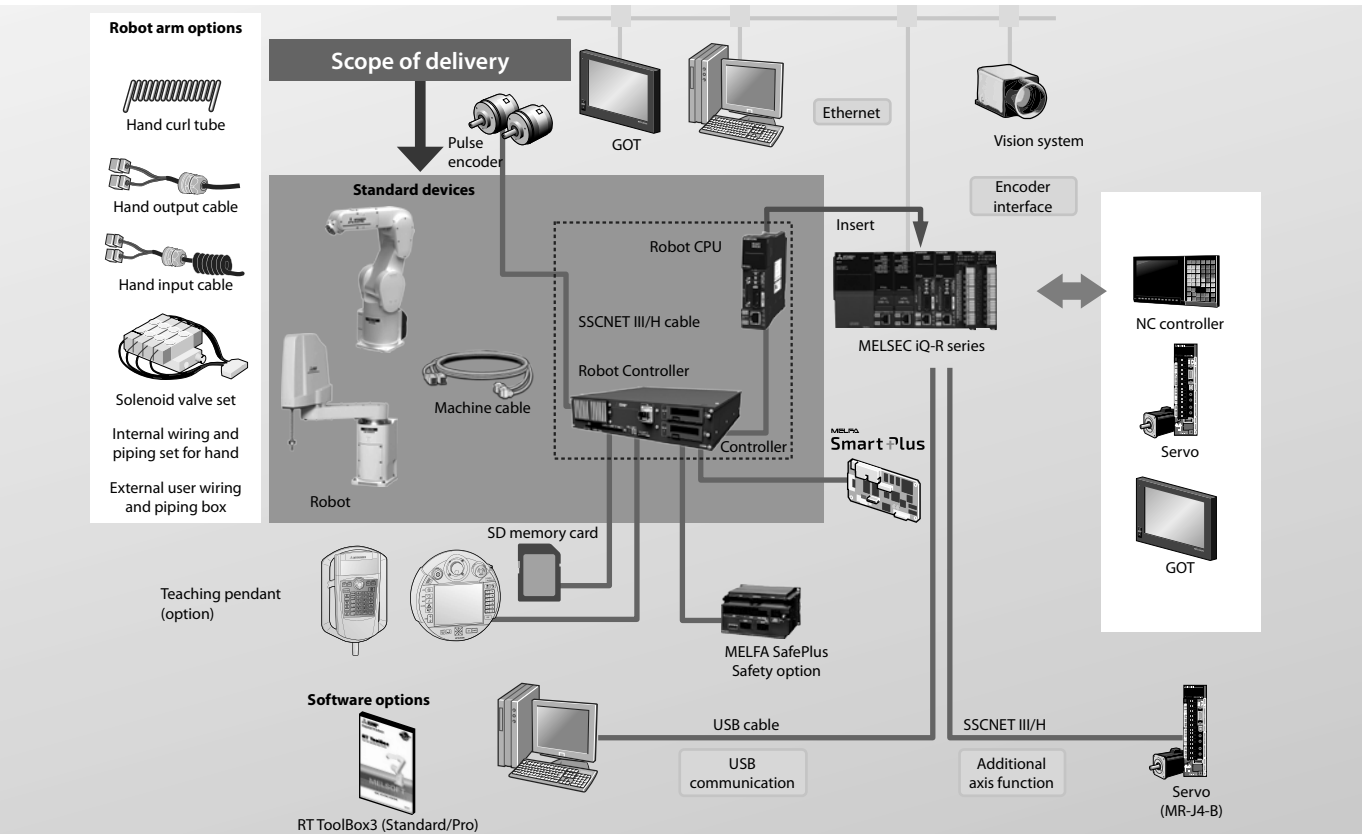

## Controller specifications



Controller CR800

### Powerful controller

Every robot system has its own compact, modular robot controller, which contains the CPU and the power electronics for controlling the robot.

Mitsubishi Electric's robot controllers have a particularly slim, compact design. No matter which Mitsubishi robot you use the programming language and options are always the same. You can add special application functions by inserting expansion option cards in the slots in the controllers. Therefore it is possible, to integrate the controller into different types of networks.

All controllers have already implemented functions like Ethernet and USB connection, additional axes control over SSCNET III/H and tracking encoder interface as a standard.

The control unit CR800 also includes the input and output card for the connection of a pneumatic or electric gripper.

Characteristics/Functions		CR800-D	CR800-R
Shipped with robot		RV-2FR/2FRL/4FR/4FRL/7FR/7FRL/7FRL/13FR/13FRL/20FR/RV-5AS/RV-8CRL RH-1FHR/3FRHR/3FRH/6FRH/12FRH/20FRH/RH-CRH	
Robot CPU		—	R16RTCPU
Path control method		PTP control and CP control	
Number of controllable axes		6 robot axes + 2 interpolation axes + 6 independent axes	
Programming language		MELFA-BASIC V/VI	
Position teaching method		Teaching method, MDI method	
Memory capacity	no. of teaching points	39000	
	no. program steps	78000	
	no. of programs	512	
External inputs/outputs	general purpose I/Os	Up to 256 optional	Up to 8192 shared with PLC CPU
	dedicated I/Os	Assigned to general-purpose I/O	Assigned to multiple CPU common device
	hand open/close	8 inputs/8 outputs	
	emergency stop I/Os	1 (redundant)	
	door switch input	1 (redundant)	
	enabling device input	—	
	mode output	1 (redundant)	
	robot error output	1 (redundant)	
	synchronization of additional axes	1 (redundant)	
Ethernet		1 (10BASE-T/ 100BASE-TX/1000BASE-T)	
USB		1 (Ver. 2.0 device functions only, mini B terminal)	1 (USB port of programmable controller CPU unit can be used.)
SD memory slot		1	
Ambient temperature		0–40 °C	0–40 (controller)/0–55 (Robot CPU)
Relative humidity		% RH 45–85	
Power supply	input voltage range	RV-2F(L)/4F(L)/7F(L), RH-1FRHR/3FRH/3FRHR/6FRH/12FRH/20FRH: 1-phase 180–253 V AC RV-7FRL/13FR(L)/20FR: 3-phase 180–253 V AC or 1-phase 207–253 V AC RV-5AS: 1-phase 100–120 V AC (200–230 V AC), RV-8CRL, RH-3CRH/6CRH: 200–230 V AC	
	power capacity	RV-2FR(L), RH-3FRH, RH-3CRH/6CRH: 0.5; RV-4FR(L), RH-3FRHR/6FRH, RV-5AS: 1.0; RH-1FRHR/12FRH/20FRH: 1.5; RV-7FR(L), RV-8CRL: 2.0; RV-7FRL/13FR(L)/20FR: 3.0	
Dimensions (WxHxD) including legs		mm 430x99.5x425	
Weight		kg 12.5	
Structure (protective specification)		Self-contained floor type/open structure (Vertical and horizontal position can be placed) (IP20) + IP54 protection box available as an option	
Grounding		Ω 100 or less (class D grounding)	



■ Controller dimensions

CR800

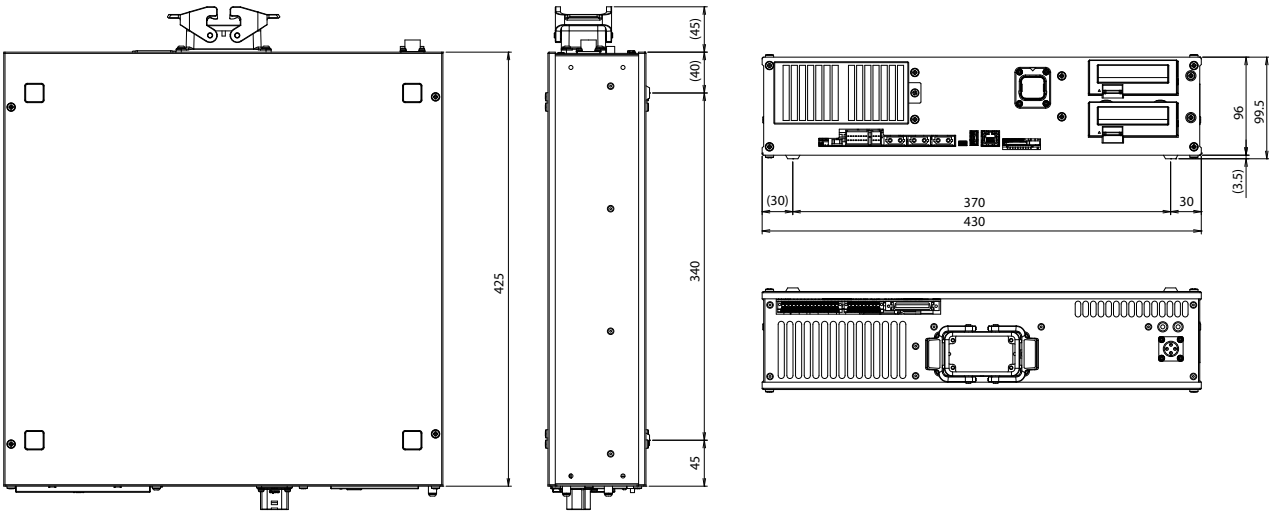

## Teaching box for the robot series



R56TB



R32TB



R56TB wall mount

### Operation and programming

The R56TB teach panel is a multifunctional control and programming terminal for all Mitsubishi Electric robot series. Its intuitive user interface makes it easy to control robot movements and perform extensive diagnostics and monitoring functions for users of all levels. All safety-critical functions such as robot movements are assigned to keys.

Programming and monitoring functions are accessed and adjusted quickly and easily via the bright 6.5" touchscreen display.

In addition to controlling robot movements the terminal has many other functions: For example, writing programs with a virtual on-screen keyboard and monitoring all system status parameters, inputs and outputs, including those accessed via the network.

A complete backup of the robot can simply be loaded or stored on a USB stick via the R56TB.

Specifications	R56TB	R32TB
Compatibility	RV series/RH series	RV series/RH series
Functions	Operation, programming and monitoring of all robot functions	
Programming and monitoring	Read out information, also during operation; program editing with virtual keyboard; display up to 14 lines of program code; I/O monitoring for up to 256 inputs and 256 outputs; service display with information on maintenance intervals; error display with details of the last 128 alarms	Read out information, also during operation, program editing with T9-Key standard, supervising of I/Os, display of error alarms, right-/left-Hand usage, 36 keys for operation selection
Software	Integrated operating system software with menu-based user interface	
Menu navigation (language)	German, English, French, Italian	English, Japanese
Display	type/dimensions	6.5" TFT display (640x480 pixels)
	technology	Touchscreen with backlight
Interfaces	USB, Ethernet for connection to the robot controller	Monochrome LCD graphic display (24 characters x 8 lines)
Connection	Direct connection to the robot controller, cable length 7 m	LCD with backlight
Protection rating	IP65	RS422 for connection to the robot controller
Weight	kg 1.25	0.9
<b>Order information</b>	Art. no. 218854	214968

Accessories	2F-TBSTS-01	Wall Mount R56TB	Wall Mount R32TB
Application	TB-Safety box for EMG output signals of TB	Option for wall mount of TB	
<b>Order information</b>	Art. no. 279057	204294	274317

**Force sensor**



**Force sensor set**

With the force sensor, our RV series and RH series <sup>①</sup> robots can be controlled to reach pre-set values of reaction force and softness when the robot contacts surrounding objects.

<sup>①</sup> except RH-CRH robots

**Features**

- Function for controlling robots while applying a specified force
- Function for controlling the stiffness of robot appendages

- Function for changing control characteristics while the robot is running
- Function for acquiring force sensor and robot positions while contact made
- Function for display force sensor data and maintaining maximum values
- Function for acquiring force sensor information synchronized to position
- Information as log data and displaying it in graph form
- Allows logging start/stop commands to be specified in robot programs
- Function for transferring acquired log files to the FTP server

Specifications	4F-FS002H-W200	4F-FS002H-W1000
Robots	RV series/RH series <sup>①</sup>	
Controller	CR800-D/R	
Max. static load (Fx, Fy, Fz / Mx, My, Mz)	200N/4Nm	1000N/30Nm
Set includes:	Force sensor, Force sensor interface unit, Sensor attachment adapter, Adapter cable for internal wiring, 24 V DC Power supply incl. 1 m cable, Serial cable between unit and sensor 5 m, SSCNET III cable 10 m	
<b>Order information</b>	Art. no. 313064	313105

<sup>①</sup> except RH-CRH robots

**MELFA SafePlus**



**“MELFA SafePlus” safety technology for robot controllers**

Functions like reduced safe speed control, safe limited control range, and safe torque monitoring are the main functions which can be activated via safety inputs, as a

result, the robots can be easily integrated into safety systems.

Simple safety logic to control safety I/Os can be programmed in the robot controller without using a dedicated Safety PLC.

Specifications	4F-SF002-01
Robots	RV series/RH series
Controller	CR800-D/R
Redundant safety in-/outputs	8 inputs/4 outputs
<b>Order information</b>	Art. no. 313061

Accessories	2F-SFDCIN-CBL02-OEM	2F-SFSDI-CBL02-OEM	2F-SFSDO-CBL02-OEM	2F-SFRIO-CBL05-OEM
Application	DCIN cable for 4F-SF002-01	SDI cable (1 safety input) for 4F-SF002-01	SDO cable (4 safety outputs) for 4F-SF002-01	RIO cable for 4F-SF002-01
Length	m 2			5
<b>Order information</b>	Art. no. 413838	413839	413840	470795

## MELFA Smart Plus card and MELFA Smart Plus card pack

### ■ MELFA Smart Plus card and MELFA Smart Plus card pack

# MELFA Smart Plus

#### Advanced intelligent functions are provided by MELFA Smart Plus

The MELFA Smart Plus card pack and the MELFA Smart Plus card with upgraded predictive-maintenance and enhanced force-sensor functions for upgraded functionality in MELFA-FR series industrial robots incorporate Mitsubishi Electric's original compact AI technology, Maisart®, to realize 60 % reductions in both takt time and system startup time to contribute to increased productivity at manufacturing sites.

Integrated functions for the various sensors and autonomous startup adjustment functions are included:

- Robot mechanism temperature compensation function
- Calibration assistance function
- Coordinated control for additional axes

Specifications	MELFA Smart Plus card pack		MELFA Smart Plus card		
	2F-DQ510	2F-DQ520	2F-DQ511	2F-DQ521	
Robots	RV-FR and RH-FR, RV-8CRL		RV-FR and RH-FR, RV-8CRL		
Controller	CR800-D/R				
Number of functions enabled	All type A functions	All type A and B functions	1 type A function	1 type B function	
<b>Order information</b>	Art. no.	325728	486379	325729	486380

	Function	Function outline
<b>Type A – Intelligent functions</b>	Calibration assistance function <ul style="list-style-type: none"> <li>● Automatic calibration</li> <li>● Work coordinate calibration</li> <li>● Relative position calibration</li> </ul>	Supports calibration of position with other equipment using 2D vision sensor <ul style="list-style-type: none"> <li>● Automatically corrects vision sensor coordinates to improve positional accuracy</li> <li>● Corrects robot and workpiece coordinates using vision sensor to improve positional accuracy</li> <li>● Correct positions between multiple robots using vision sensor Improve positional accuracy of coordinated actions</li> </ul>
	Robot mechanism thermal compensation function	Compensate for thermal expansion of robot arm to improve positional accuracy
	Coordinated control of additional axes	Perform high-accuracy coordinated (interpolation) work with additional axes (direct coaxial)
	Preventive maintenance function (Maintenance simulation, wear calculation function)	Manage robot condition by tracking operational status
<b>Type B – AI functions</b>	MELFA-3D Vision enhancement function	Utilizes AI technology to automate 3D vision sensor adjustments and improve measurement and recognition performance
	Enhancement function for force sense control	Utilizes AI technology for repeated learning in short time periods and to calculate optimal insertion patterns

Internal/external wiring



**Internal wiring/piping set for hand**

This set consists of hand input cables and hoses that can be routed through the spindle until the end of the arm 2.

A bracket to fix the set on the arm 2 is included. The set can be used with an optional solenoid valve.

Specifications	1F-HS304S-01	1F-HS408S-01	1F-HS604S-01
Robots	RH-1FRHR/RH-3FRH	RH-6FRH	RH-12FRH/20FRH
Stroke	mm —	200	350
Length from the shaft end	mm 300		400
Attachment	4 air hoses (Ø 3), 8 hand input cables (0.2 mm <sup>2</sup> ) 2 power cables (0.3 mm <sup>2</sup> )	4 air hoses (Ø 4), 8 hand input cables (0.2 mm <sup>2</sup> ) 2 power cables (0.3 mm <sup>2</sup> )	4 air hoses (Ø 6), 8 hand input cables (0.2 mm <sup>2</sup> ) 2 power cables (0.3 mm <sup>2</sup> )
Remarks	Both ends are free. Eight reducers (Ø 3 to Ø 4) are attached. The robot arm side is connector (HC1, HC2), and one side is free.	Both ends are free. The robot arm side is connector (HC1, HC2), and one side is free.	
Weight	kg 0.4		
<b>Order information</b>	Art. no. 250468	250469	254396

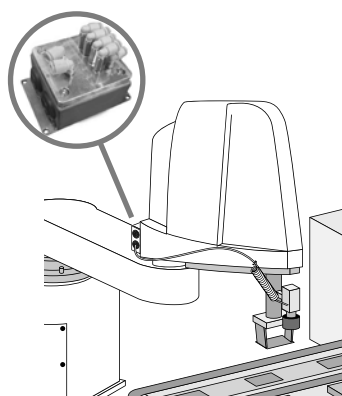

**External wiring/piping box**

With this option hand output and input cables and pneumatic hoses can be routed from the back of arm 2 to the spindle end outside the robot casing. Connections for connecting the external hoses and brackets for attaching the cables and hoses are

included. The option can also be used for oil mist and cleanroom models. A bracket to fix the set on the arm 2 is included. The set can be used with an optional solenoid valve.

Specifications	1F-UT-BOX	1F-UT-BOX-01
Robots	RH-3FRH/6FRH	RH-12FRH/20FRH
Attachment	Eight air hoses (connect to solenoid valve) Installation screws (conical spring washer, plain washer)	
Weight	kg 0.5	
<b>Order information</b>	Art. no. 251104	254398

Pulled out from robot arm

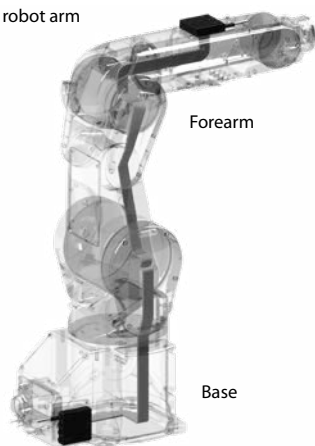

**Forearm external wiring set/base external wiring set**

With these options the hand input signal cables and the communication cables etc. can be led out of the bottom of the forearm and from the side of the base.

Use the recommended pairing in the table to led out the same cables on the arm side and at the base.

Specifications	1F-HB01S-01	1F-HA01S-01
Robots	RV-4FRL/7FR/7FRL/7FRL/13FR/13FRL/20FR	
Part name	Forearm external wiring set	Base external wiring set
Hand input signal cable	8	—
Ethernet cable	1	
Additional cable	4	
Recommended pairing	●	
<b>Order information</b>	Art. no. 257936	257935

## Valve sets, bellows

### Solenoid valve sets



#### Solenoid gripper control valve sets

This option is used to control the gripper tool installed on the robot arm. The valve set comes with all the components required for installation, including the branch manifold, couplings and dampers.

The valves are fitted with plug-in control cables for quick and easy wiring. The solenoid valve sets are for use with oil-free compressed air.

Specifications	1F-VV0□E-01		1E-VDO□E		
	1	2	1	2	
No. of valves	1	2	1	2	
Range of use (robot type)	RH-1FHR		RV-2FR(B)/RV-2FRL(B)		
Valve function	Vacuum valve		Double solenoid		
Operating method	Two-stage ejector		Internal pilot method		
Effective sectional area (CV value)	1.5 mm		1.5 mm		
Operating pressure range	3–6 bar		2–7 bar		
Maximum pressure	10 bar		10 bar		
Response time	<2.5 ms at 24 V DC		<12 ms at 24 V DC		
Max. operating frequency	5 Hz		5 Hz		
Ambient temperature	-5–50 °C		-10–50 °C		
Coil rated voltage	24 V DC ±10 %		24 V DC ±10 %		
<b>Order information</b>	Art. no.	277712	277713	47397	47398

Specifications	1S-VDO□E-05	1F-VDO□E-01				1S-VDO□E-01				1F-VDO□E-02				1F-VDO□E-03				
	4	1	2	3	4	1	2	3	4	1	2	3	4	1	2	3	4	
No. of valves	4	1	2	3	4	1	2	3	4	1	2	3	4	1	2	3	4	
Range of use (see page )	RH-3FRHR	RV-5AS (only 1 and 2 valves) RH-1FRHR, RH-3FRH, RH-6FRH				RH-12/RH-20FRH				RV-4FRL, RV-7FR, RV-7FRL				RV-13FR, RV-20FR				
Valve function	Double solenoid 5/2	Double solenoid 5/2				Double solenoid 5/2				Double solenoid 5/2				Double solenoid 5/2				
Operating method	Internal pilot method	Internal pilot method				Internal pilot method				Internal pilot method				Internal pilot method				
Effective sectional area (CV value)	0.64 mm	0.64 mm				0.64 mm				0.64 mm				0.64 mm				
Operating pressure range	1–7 bar	1–7 bar				1–7 bar				1–7 bar				1–7 bar				
Maximum pressure	10 bar	10 bar				10 bar				10 bar				10 bar				
Response time	<22 ms at 5 bar	<22 ms at 5 bar				<22 ms at 5 bar				<22 ms at 5 bar				<22 ms at 5 bar				
Max. operating frequency	5 Hz	5 Hz				5 Hz				5 Hz				5 Hz				
Ambient temperature	-10–50 °C	-10–50 °C				-10–50 °C				-10–50 °C				-10–50 °C				
Coil rated voltage	24 V DC ±10 %	24 V DC ±10 %				24 V DC ±10 %				24 V DC ±10 %				24 V DC ±10 %				
<b>Order information</b>	Art. no.	238375	250470	250471	250472	250473	153057	153058	153059	153062	255281	255282	255283	255284	268829	268830	268831	268832

### Bellows



#### Bellows

By adding the bellows to the Z axis, the IP protection can be increased to IP65 for the SCARA robots RH-1FRHR, RH-6FRH, RH-12FRH, and RH-20FRH.

Bellow type	Robot type	Z-Axis length	Art. no.
1F-JS-21	RH-1FRHR	150 mm	277714
1F-JS-01	RH-6FRH	200 mm	251456
1F-JS-02	RH-6FRH	340 mm	251457
1F-JS-05	RH-12FRH	350 mm	255689
1F-JS-06	RH-12FRH	450 mm	255690
1F-JS-09	RH-20FRH	350 mm	255693
1F-JS-10	RH-20FRH	450 mm	255694

**Interface boards for robot controllers**

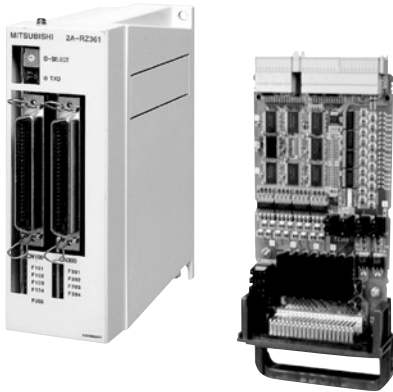

**I/O interface**

You can increase the number of I/Os to a maximum of 64 by adding 2D-TZ378 interface modules.

By adding 2A-RZ371 slot-in cards you can increase the number of remote I/Os to 256 (depends on the controller model).

Specifications	2A-RZ371	2D-TZ378
Application	Interface for additional inputs/outputs	
Type	Decentralized I/O box with 32 inputs and 32 outputs	Slot-in card with 32 inputs and 32 outputs
Range of use	Only for D controller	
Rated load voltage	Inputs: 12 V/24 V; outputs: 12 V/24 V, max. 0.1 A/per output	
Max. no. of usable I/O boxes	7	2

Order information	Art. no.	124658	218862
-------------------	----------	--------	--------

For I/O connection cables see page 54.



**Profinet I/O / EtherCAT / CC-Link IE Field / EtherNet/IP interface**

These interface cards make it possible to integrate the robot controller in a

Profinet I/O, in an EtherCAT, in a CC-Link IE Field or in an Ethernet/IP network.

Specifications	2D-TZ535-PN-SET	2F-DQ535-ECT-SET	2F-DQ535-CCIEF-SET	2D-TZ535-EIP-SET
Application	Profinet I/O	EtherCAT	CC-Link IE Field	EtherNet/IP
Range of use	Only for D controller			
Communications cable	Industrial Ethernet twisted pair cable			
Transmission speed	100 Mbit/s		1 Gbit/s	100 Mbit/s
Number of I/O data	Max. 256 bytes send and max. 256 bytes receive			

Order information	Art. no.	269546	413963	324560	282409
-------------------	----------	--------	--------	--------	--------



**CC-Link interface**

The 2D-TZ576 interface makes it possible to integrate the CR-D robot controller in a CC-Link network.

The CC-Link interface is a high-speed bit (for I/Os) and word (for data registers) network card.

Specifications	2D-TZ576
Application	CC-Link interface
Range of use	Only for D controller
Communications cable	Shielded 3-core twisted cable
Max. number of I/O points and data registers	126 I/Os/16 data register
Refresh rate	7.2 ms
Communications distances	100 m at 10 Mbps, 150 m at 5 Mbps, 250 m at 2.5 Mbps, 600 m at 0.62 Mbps, 1500 m at 0.15 Mbps

Order information	Art. no.	219063
-------------------	----------	--------



**Profibus interface**

These interface cards make it possible to integrate the robot controller in a Profibus network.

Specifications	2D-TZ577
Application	Profibus DP interface
Range of use	Only for D controller
Communications cable	Twisted pair cable
Communications distances	1200 m at 9.6/19.2/93.75 Kbps, 1000 m at 187.5 Kbps, 400 m at 500 Kbps, 200 m at 1500 Kbps
Max. no. of communications words	122

Order information	Art. no.	218861
-------------------	----------	--------

## Adaptor cables, connectors

### ■ Gripper signal cables



#### Connection cables

A variety of different cables are available for connecting the control and status monitoring signals of the gripper tools.

When the pneumatic gripper is used you need to monitor the position of the gripper.

You should thus always connect a gripper signal input cable when you use the pneumatic gripper. One end of the cable set is fitted with a plug for the gripper's sensor signals. The other end is without connectors and can be wired as required for your system.

#### Hand output cable

Specifications	1E-GR355	1F-GR355-02	1F-GR605-01	1S-GR355-02
Type	Hand signal output cable			
Range of use (robot type)	RV-2FR(B)/RV-2FRL(B)	RV-4FRL, RV-7FR/RV-7FRL/7FRL, RV-13FR/13FRL, RV-20FR	RH-1FRHR, RH-3FRH/RH-6FRH/RH-12FRH/RH-20FRH	RH-3FRHR
Design	Single sided with connector			
Application	Custom-made magnetic valve set			
Length	mm 350	500	1050	450
<b>Order information</b>	Art. no. 47391	255285	250467	166272

#### Hand input cable

Specifications	1F-HC35C-01	1F-HC35C-02	1F-HC35S-02	1S-HC00S-01	1S-HC30C-11
Type	Hand signal input cable				
Range of use (robot type)	RH-1FRHR, RH-3FRH, RH-6FRH	RH-12FRH/RH-20FRH	RV-4FRL, RV-7FR, RV-7FRL/7FRL, RV-13FR/13FRL, RV-20FR	RH-3FRHR	RV-2FR(B)/RV-2FRL(B)
Design	Single sided with connector				
Application	Monitoring of the gripper condition				
No. of cores	12		10	6	11
Length	mm 1650	1800	1000	1210	300
<b>Order information</b>	Art. no. 250474	254395	255286	238376	257063

### ■ Connectors

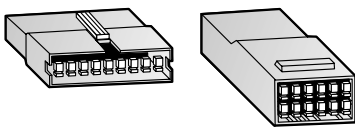

#### The connection to your system

Choose additional components to configure the optimal interface between the robot system and your application. The wide range of options makes it possible to configure the robot precisely for the individual requirements of your application.

The connectors listed in the following table can be used for making your own cables for the gripper input and output signals (see also the table above).

Specifications	RV-F / RV-FR Connector set	RH-FH / RH-FRH Connector set
Type	Connector set for OP1/2/3/4 & GR1/2 signals and LAN	Connector set for HC1/2 & GR1/2 signals
Range of use (robot type)	All MELFA RV-FR robots	All MELFA RH-FRH robots
Design	Complete set	
Shipping contents	Plug and contacts	
<b>Order information</b>	Art. no. 268039	273182



**Hand curl tube**

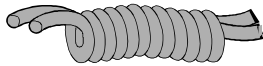

**Replacement gripper hoses**

These spiral hoses are for use with the pneumatic gripper. They are also suitable for use with cleanroom robots.

Specifications	1E-ST0404C	1E-ST0408C-300	1N-ST0608C-01	1S-ST0304S
Type	Spiral hose			
Range of use (robot type)	RV-2FR(B)/2FRL(B), RV-4FRL, RV-7FR/7FRL/7FRL	RH-1FRHR, RH-3FRH/6FRH	RH-12FRH/20FRH, RV-13FR/20FR	RH-3FRHR
Application	For double pneumatic gripper	For quadruple pneumatic gripper		For double pneumatic gripper
Dimensions	mm 4xØ 4	8xØ 4	8xØ 6	4xØ 3
<b>Order information</b>	Art. no. 47389	270236	269556	238377

**Machine cables for robots and controllers**



**Replacement cables for power and signal connections**

These machine cables make it possible to decrease/increase the distance between the controller and the robot arm. Versions are available for either flexible and fixed routing of the cables between the controller and the robot arm.

Use the flexible versions for installation of the cables in drag chains and similar configurations. These cables replace the standard cables supplied with the robot.

**Fixed installation**

Specifications	1F-02UCBL-41	1F-03UCBL-42	1F-10UCBL-41/-42/-43	1F-15UCBL-41/-42/-43	1F-20UCBL-41/-42/-43
Type	Replacement cable for a fixed installation				
Range of use (robot type)	RV-2FR, RV-2FRL, RV-4FRL, RV-7FR/7FRL/7FRL, RV-13FR/13FRL, RV-20FR, RH-3FRHR, RH-6FRH, RH-12FRH, RH-20FRH, RV5-AS	RH-3CRH/6CRH	-41: RV-2FR, RV-2FRL, RV-4FRL, RV-7FR/7FRL/7FRL, RV-13FR/13FRL, RV-20FR, RH-3FRHR, RH-6FRH, RH-12FRH, RH-20FRH, RV5-AS -42: RH-3CRH/6CRH -43: RV-8CRL		
Minimum bending radius	More than 150 mm				
Protection rating	Oil-proof specification sheath				
Length	m 2	3	10	15	20
<b>Order information</b>	Art. no. 325730	504046	313106/504047/492800	313107/504048/492801	327863/504049/492892

**Flexible installation**

Specifications	1F-10LUCBL-41/-42/-43	1F-15LUCBL-41/-42/-43	1F-20LUCBL-41/-42/-43
Type	Replacement cable for a flexible installation in a drag chain		
Range of use (robot type)	-41: RV-2FR, RV-2FRL, RV-4FRL, RV-7FR/7FRL/7FRL, RV-13FR/13FRL, RV-20FR, RH-3FRHR, RH-6FRH, RH-12FRH, RH-20FRH -42: RH-3CRH/6CRH -43: RV-8CRL		
Minimum bending radius	More than 100 mm		
Cable bear isovolumetric ration	≤50 %		
Max. movement speed	2000 mm/s		
Guidance of life count	7.5 million times		
Protection rating	Oil-proof specification sheath		
Length	m 10	15	20
<b>Order information</b>	Art. no. 313108/504050/492893	313109/504515/492894	327864/504516/492895

## Connection cables, controller protection box, batteries

### ■ Connection cables for PCs and inputs/outputs



#### Connection cables, connectors

The MR-J3USBCBL3M cable is for establishing a USB connection between the robot controller and a personal computer.

The I/O connection cable is for connecting peripherals to the parallel I/O interface.

One end of the cable is fitted with a connector for the controller's parallel I/O port. The other end is supplied without a connector so that you can connect the appropriate connectors for your equipment.

Specifications	MR-J3USBCBL3M	2A-CBL05	2A-CBL15	2D-CBL05	2D-CBL15	
Type	USB connection PC-controller	I/O cable for 2A-RZ371		I/O cable for 2D-TZ378		
Range of use	FR series	Only for D controller				
Design	Mini USB	Plug on one side				
Length	m	3	5	5	15	
<b>Order information</b>	Art. no.	160229	47387	59947	218857	218858

### ■ Controller protection box (IP54)



The controller protection box for the control unit CR800 prevents the penetration of oil mist or other influences from the operating environment.

The front of the housing is equipped with a mode switch and a connector for the teaching box.

Specifications	CR800-MB
Type	Controller protection box
Application	Controller CR800
Dimensions (WxHxD)	mm 495x250x725
<b>Order information</b>	Art. no. 313062

### ■ Buffer batteries



#### Batteries

The backup batteries are used to maintain the encoder and memory power supply.

The number of batteries depends on the robot type. For the FR series, you can order the battery set directly.

Specifications	RH-FRH series	RV-FR series	Art. no.
MR-BAT6V1	Number 4		248692
A6BAT	Number —		4077
Q6BAT	Number —		130376
Battery set RH-FRH/RV-FR	for RH-FRH series and RV-FR series consists of 4 pcs. MR-BAT6V1		327911

Options overview for all robots

Option	Marking	RV-2FR(B)/RV-2FRL(B)	RV-4FRLM	RV-7FRM/ RV-7FRLM RV-7FRLLM	RV-13FRM/ RV-13FRLM/ RV-20FRM	RV-5AS	RV-8CRL	RH-3FRH	RH-6FRH	RH-12FRH/ RH-20FRH	RH-1FRHR	RH-3FRHR	RH-3CRH/ RH-6CRH/	Art. no.	See Page
Teaching Box	R32TB	●	●	●	●	●	●	●	●	●	●	●	●	214968	46
Teaching Box	R56TB	●	●	●	●	●	●	●	●	●	●	●	●	218854	46
EMG-Output for TB_EMB	2F-TBSTS-01	●	●	●	●	●	●	●	●	●	●	●	●	279057	—
Force sensor	4F-FS002H-W200	●	●	●	●	●	●	●	●	●	●	●	●	313064	47
	4F-FS002H-W1000	●	●	●	●	●	●	●	●	●	●	●	●	313105	47
2-piece force sensor conversion cable set	1F-ASSISTA-ADCBL					●								504043	—
Vision sensor mounting bracket	1F-ASSISTA-2DVSFLG					●								504044	—
MELFA SafePlus	4F-SF002-01	●	●	●	●		●	●	●	●	●	●	●	313061	47
MELFA Smart Plus card pack	2F-DQ510	●	●	●	●		●	●	●	●	●	●	●	325728	48
	2F-DQ520	●	●	●	●		●	●	●	●	●	●	●	486379	48
MELFA Smart Plus card	2F-DQ511	●	●	●	●		●	●	●	●	●	●	●	325729	50
	2F-DQ521	●	●	●	●		●	●	●	●	●	●	●	486380	50
Quadruple valve set	1S-VD04E-05											●		238375	50
Single valve set	1E-VD01E	●												47397	50
Double valve set	1E-VD02E	●												47398	50
Single valve set	1F-VD01E-01					●		●	●		●			250470	50
Double valve set	1F-VD02E-01					●		●	●		●			250471	50
Triple valve set	1F-VD03E-01							●	●		●			250472	50
Quadruple valve set	1F-VD04E-01							●	●		●			250473	50
Single valve set	1F-VD01E-02		●	●										255281	50
Double valve set	1F-VD02E-02		●	●										255282	50
Triple valve set	1F-VD03E-02		●	●										255283	50
Quadruple valve set	1F-VD04E-02		●	●										255284	50
Single valve set	1F-VD01E-03				●									268829	50
Double valve set	1F-VD02E-03				●									268830	50
Single valve set	1S-VD01E-01									●				153057	50
Double valve set	1S-VD02E-01									●				153058	50
Triple valve set	1S-VD03E-01									●				153059	50
Quadruple valve set	1S-VD04E-01									●				153062	50
Single vacuum valve set	1F-VV01E-01										●			277712	50
Double vacuum valve set	1F-VV02E-01										●			277713	50
Bellows	1F-JS-21										●			277714	50
	1F-JS-01								●					251456	50
	1F-JS-02								●					251457	50
	1F-JS-05									●				255689	50
	1F-JS-06									●				255690	50
	1F-JS-09									●				255693	50
	1F-JS-10									●				255694	50
CC-Link interface ①	2D-TZ576	●	●	●	●	●	●	●	●	●	●	●	●	219063	51
CC-Link IE Field interface ①	2F-DQ535-CCIEF-SET	●	●	●	●	●	●	●	●	●	●	●	●	324560	51
Profibus interface ①	2D-TZ577	●	●	●	●	●	●	●	●	●	●	●	●	218861	51
EtherCat interface ①	2F-DQ535-ECT-SET	●	●	●	●	●	●	●	●	●	●	●	●	413953	51
Profinet interface ①	2D-TZ535-PN-SET	●	●	●	●	●	●	●	●	●	●	●	●	269546	51
Ethernet/IP interface ①	2D-TZ535-EIP-SET	●	●	●	●	●	●	●	●	●	●	●	●	282409	51
I/O interface ①	2D-TZ378	●	●	●	●	●	●	●	●	●	●	●	●	218862	51
	2A-RZ371	●	●	●	●	●	●	●	●	●	●	●	●	124658	51
Hand signal output cable	1E-GR355	●												47391	52
	1F-GR355-02		●	●	●									255285	52
	1F-GR605-01							●	●	●	●			250467	52
	1S-GR355-02											●		166272	52
Hand signal input cable	1F-HC35C-01							●	●		●			250474	52
	1F-HC35C-02									●				254395	52
	1F-HC355-02		●	●	●									255286	52
	1S-HC005-01											●		238376	52
	1S-HC30C-11	●												257063	52

## Options overview for all robots

Option	Marking	RV-2FR(B)/ RV-2FRL(B)	RV-4FRLM	RV-7FRM/ RV-7FRLM	RV-13FRM/ RV-13FRLM/ RV-5AS RV-7FRLM RV-20FRM	RV-8CRL	RH-3FRH	RH-6FRH	RH-12FRH/ RH-20FRH	RH-1FRHR	RH-3FRHR	RH-3CRH/ RH-6CRH/	Art. no.	See Page
Connector sets	RH-FRH Hand connector set						●	●	●	●	●		273182	52
	RV-F/RV-FR connector set		●	●	●								268039	52
Hand curl tube	1E-ST0404C	●	●	●									47389	53
	1E-ST0408C-300						●	●		●			270236	53
	1S-ST0304S										●		238377	53
	1N-ST0608C-01				●				●				269556	53
Internal wiring and piping set	1F-HS304S-01						●			●			250468	49
	1F-HS408S-01							●					250469	49
	1F-HS604S-01								●				254396	49
External wiring/piping box	1F-UT-BOX						●	●					251104	49
	1F-UT-BOX-01								●				254398	49
Forearm external wiring set	1F-HB01S-01		●	●	●								257936	49
Base external wiring set	1F-HA01S-01		●	●	●								257935	49
Extension cable for fixed installation	1F-02UCBL-41	●	●	●	●	●	●	●	●	●	●		325730	44
	1F-10UCBL-41	●	●	●	●	●	●	●	●	●	●		313106	53
	1F-15UCBL-41	●	●	●	●	●	●	●	●	●	●		313107	53
	1F-20UCBL-41	●	●	●	●	●	●	●	●	●	●		327863	53
	1F-03UCBL-42											●	504046	53
	1F-10UCBL-42											●	504047	53
	1F-15UCBL-42											●	504048	53
	1F-20UCBL-42											●	504049	53
	1F-10UCBL-43					●							492800	53
	1F-15UCBL-43					●							492801	53
	1F-20UCBL-43					●							492892	53
Extension cable for flexible installation in a drag chain	1F-10LUCBL-41	●	●	●	●		●	●	●	●	●		157582	53
	1F-15LUCBL-41	●	●	●	●		●	●	●	●	●		313109	53
	1F-20LUCBL-41	●	●	●	●		●	●	●	●	●		327864	53
	1F-10LUCBL-42											●	504050	53
	1F-15LUCBL-42											●	504515	53
	1F-20LUCBL-42											●	504516	53
	1F-10LUCBL-43					●							492893	53
	1F-15LUCBL-43					●							492894	53
1F-20LUCBL-43					●							492895	53	
PC connection cable USB	MR-J3USBCBL3M	●	●	●	●	●	●	●	●	●	●	●	160229	54
Connection cable for I/O interface <sup>①</sup>	2A-CBL05	●	●	●	●	●	●	●	●	●	●	●	47387	54
	2A-CBL15	●	●	●	●	●	●	●	●	●	●	●	59947	54
	2D-CBL05	●	●	●	●	●	●	●	●	●	●	●	218857	54
	2D-CBL15	●	●	●	●	●	●	●	●	●	●	●	218858	54
Controller protection box (IP54)	CR800-MB	●	●	●	●	●	●	●	●	●	●	●	313062	54
Wall mount	R32TB wall mount	●	●	●	●	●	●	●	●	●	●	●	274317	46
Wall mount	R56TB wall mount	●	●	●	●	●	●	●	●	●	●	●	204294	46

① only for D controller

## MELFA-BASIC programming

### Easy-to-Learn MELFA-BASIC Programming language

Mitsubishi Electric robots are controlled with programs written in the powerful MELFA BASIC programming language. In addition to the familiar standard BASIC instructions and constructs like FOR ... NEXT and GOTO, MELFA BASIC also has some extensions required for robots, including additional data types, instructions for movement and gripper control and I/O instructions. The familiarity of standard BASIC makes it easy for beginners to get started with robot programming.

Despite its simplicity and short learning curve, MELFA BASIC is a powerful language that can be used to create very complex robot programs MELFA BASIC VI allows structured programming with functions and re-use code and ready-made libraries are additionally improving the reusability and readability.

#### Programming

Robot programs are written with the MELFA BASIC instructions with the help of a PC and the teaching box. The positions

are defined with the teaching box and the actual program is written on the PC.

Programs are written using the RT Toolbox3 programming and project managing software for industrial robots. You can find more information about the programming software on the following pages.

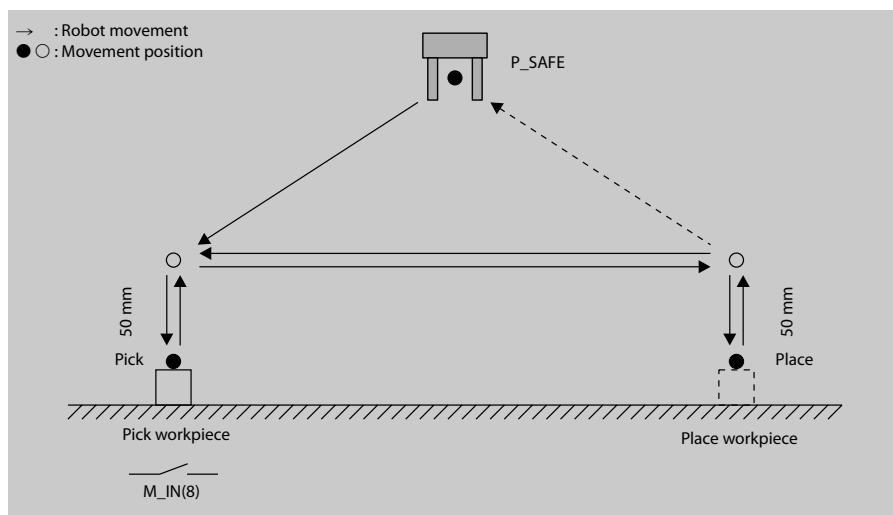

#### Sample program

The sample program below is for a pick-and-place operation. The input signal M\_IN(8) tells the program that there is a workpiece in position Pick. When a workpiece is present the input signal is set to 1 and the pick-and-place operation is performed. The workpiece is picked up from position Pick and deposited in position Place. If no workpiece is present the robot remains in the retracted position P\_SAFE.

#### Pick-and-Place Program

1	MVS P_SAFE	Move to safe position
2	Wait M_IN(8) = 1	Wait until input bit 8 is set
3	HOPEN 1	Open gripper 1
4	*PickPlace	Jump-Destination "PickPlace"
5	MVS Pick, -50	Move longitudinally to a position 50 mm from "Pick" relative to the tool Z-direction
6	MVS Pick	Move to position "Pick"
7	HCLOSE 1	Close gripper 1
8	DLY 0.2	Wait for 0.2 s to ensure proper closing of gripper
9	MVS Pick, -50	Move longitudinally to a position 50 mm from "Pick" relative to the tool Z-direction
10	MVS Place, -50	Move longitudinally to a position 50 mm from "Place" relative to the tool Z-direction
11	MVS Place	Move to position "Place"
12	HOPEN 1	Open gripper 1 and deposit workpiece
13	DLY 0.2	Wait for 0.2 s to ensure proper opening of gripper
14	MVS Place, -50	Move longitudinally to a position 50 mm from "Place" relative to the tool Z-direction
15	IF M_IN(8) = 1 THEN GOTO *PickPlace	If another workpiece is present repeat the pick-and-place operation
16	MVS P_SAFE	If no workpiece is present return to safe position and end program
17	END	Program end

RT ToolBox3

RT ToolBox3 is a software for program creation and total engineering support. This PC software supports everything from system startup to debugging, simulation, maintenance and operation. This includes programming and editing, operational checking before robots are installed, measuring process tact

time, debugging during robot startup, monitoring robot operation after startup, and troubleshooting.

- Compatible with Windows® XP, Windows® Vista, Windows® 7, Windows® 8 and Windows® 10.
- Support of all MELFA robots

- Support for all processes, from programming and startup to maintenance
- Enhanced simulation functions
- Advanced maintenance functions
- Extended documentation function

Enhanced RT ToolBox3 visual functions

- Set parameters can be displayed visually to prevent setting errors.
- Display of teaching positions and trajectories of endpoints.
- Hands can be created and then attached to the robot.
- 3D polygonal models can be imported into the program. (Applicable 3D data file formats: STL, OBJ)

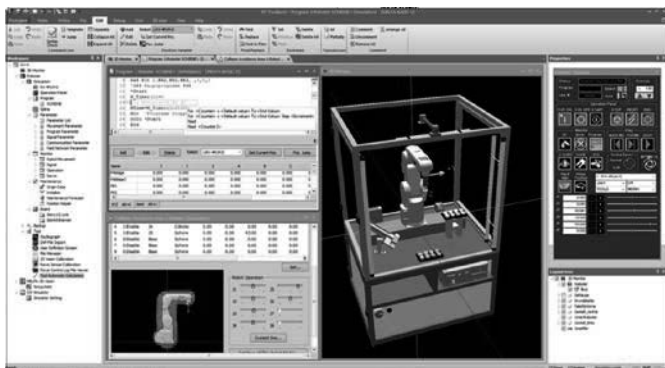

Program editing and debugging functions

Creation of programs in MELFA-BASIC IV/V/VI languages.\* Improvement of work operations by a multi-window format and the various editing functions. This is helpful for use in checking operations such as the execution of program steps, setting of breakpoint settings, and other tasks.

\* MELFA-BASIC is a programming language that further expands upon and develops the commands needed for robot control. In MELFA-BASIC, the expansion of the command as well as parallel processing or structuring that were difficult to realize in BASIC language can make it possible to operate MELFA easily.

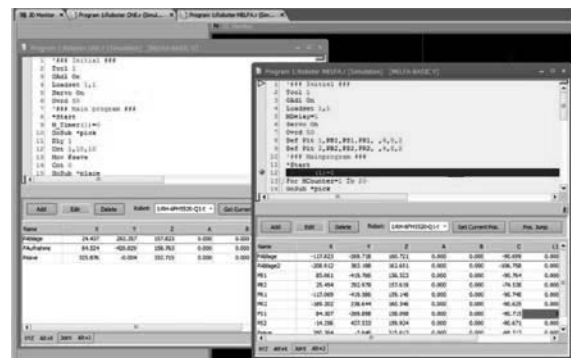

Linked to iQ Works2

- Integrated Software Suite  
Consists of GX Works3, MT Works2, GT Works3, RT ToolBox3 and FR Configurator2, which are programming software for each respective product
- System management software  
MELSOFT Navigator is the central system configuration incorporating an easy-to-use, graphical user interface with additional project-sharing features such as system labels and parameters.

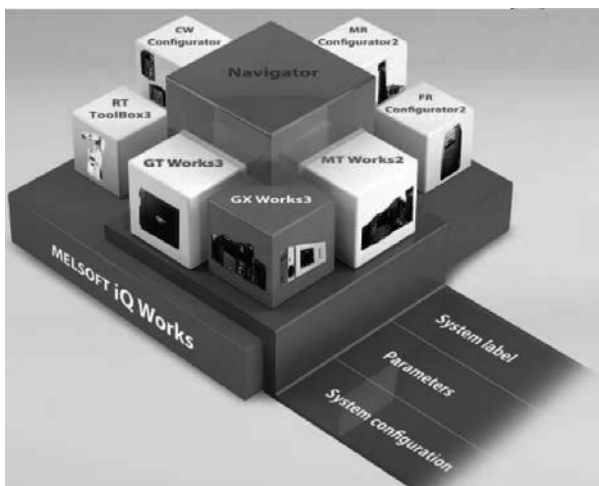

Simulation functions

Offline robot motion and tact time check for designated parts of a program.



3D viewer

Graphical representation of a work along with the dimensions, color and other specified details of the work area to be gripped.

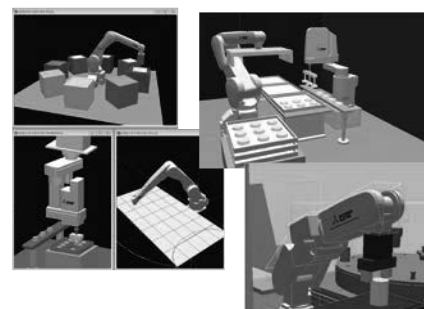

**Monitor functions**

This is used to monitor program execution status and variables, input signals, etc.)

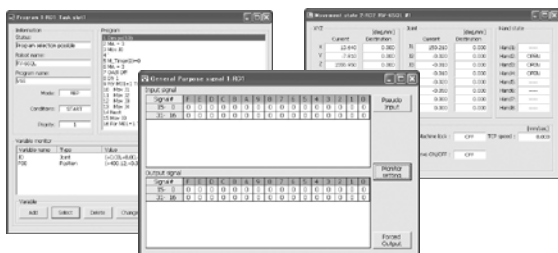

**Maintenance functions**

These functions include maintenance forecast, position recovery support, parameter management, etc.

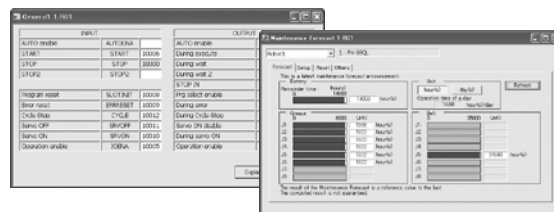

**RT ToolBox3 Pro**

**A 3D robot simulator offers powerful support for system design and preliminary layout.**

RT ToolBox3 Pro offers an add-in tool <sup>①</sup> for SolidWorks <sup>②</sup> used for robot simulation in production systems on PC's converting processing paths of workpieces into robot position data. Adding RT ToolBox3 Pro into the SolidWorks platform adds to and expands on the robot simulation functions.

- Loading of part data from peripheral created in SolidWorks® devices and rearrangement
- Installation of hands by CAD files
- Handling of workpieces
- Creating operation data from 3D CAD source data

- Offline teaching in 3D CAD surrounding
- Creation of robot programs (template)
  - Workflow processes can be created using a combination of the offline teaching and CAD link functions and then converted into robot programs. (MELFA-BASIC IV, V, VI format)
- Simulation of robot operations
- Display of the robot movement path in the application/the workspace
- Interference checks between the robot and peripheral devices
- Saving simulated movements to video files (AVI format)

- Measurement of cycle times
- Robot program debugging functions
- Jog function – teaching the robot
- Installation of a traveling axis to verify the operation of the system equipped with this.
- Calibration of point sequence data of CAD coordinates and robot coordinate data

<sup>①</sup> An add-in tool is a software program that adds certain functions to application software packages.

<sup>②</sup> SolidWorks® is a registered trademark of SolidWorks Corp, (USA).

**Automatic robot program creation function**

The teaching position data and robot operation programs necessary for operating robots can be generated automatically by simple loading of 3D CAD data<sup>③</sup> for the applicable works into SolidWorks® and then setting of processing conditions and areas using RT ToolBox3 Pro.

<sup>③</sup> Formats that can be loaded into SolidWorks®

- |   |   |  |
|---|---|--|
| <ul style="list-style-type: none"> <li>• IGES</li> <li>• STEP</li> <li>• ParasolidR</li> <li>• SAT (ACISR)</li> <li>• Pro/ENGINEERR</li> <li>• CGR (CATIARgraphics)</li> <li>• Unigraphics</li> </ul> | <ul style="list-style-type: none"> <li>• PAR (Solid Edge TM)</li> <li>• IPT (Autodesk Inventor)</li> <li>• DWG</li> <li>• DXFTM</li> <li>• STL</li> <li>• VRML</li> <li>• VDA-FS</li> </ul> | <ul style="list-style-type: none"> <li>• Mechanical Desktop</li> <li>• CADKEYR</li> <li>• Viewpoint</li> <li>• RealityWave</li> <li>• HOOPS</li> <li>• HCG (Highly compressed graphics)</li> </ul> |
|---|---|--|
- Note: Check the SolidWorks website and other published documents for the latest specifications.

**Example screens for RT ToolBox3 Pro**

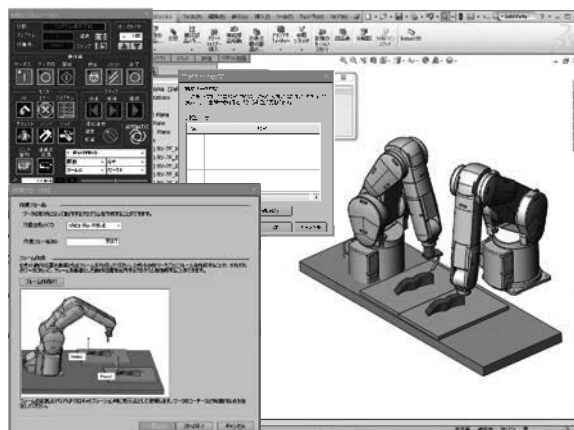

**RT VisualBox**

**ASSISTA and the camera capture the target using the “RT VisualBox” auto-focus function.**

**“RT VisualBox” proprietary engineering tool**

The RT VisualBox programming tool developed by Mitsubishi Electric is a visual programming software for MELFA ASSISTA. Intuitive flowchart programming makes it easy to create programs by simply drag-and-drop blocks, requiring only the parameters for the functions to be set. No robot programming knowledge is needed to get MELFA ASSISTA working. You can simulate the operation of the Cobot without hardware being installed. A set-up wizard provides operators with an easier more intuitive methodology for peripherals configurations.

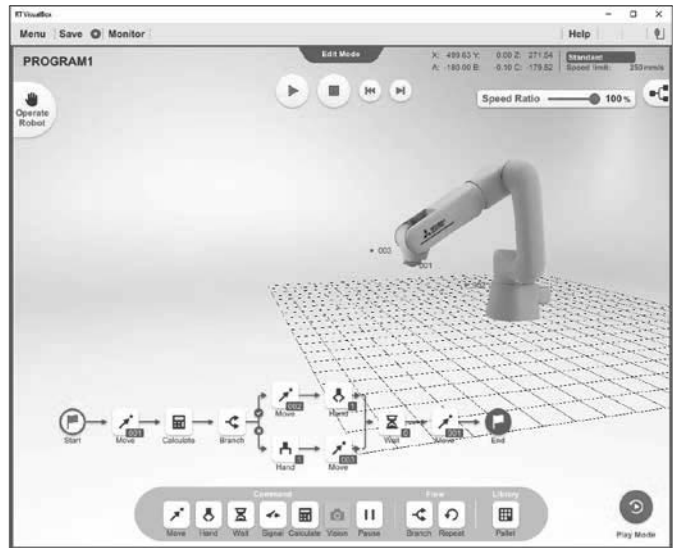

**Example screens for RT VisualBox**

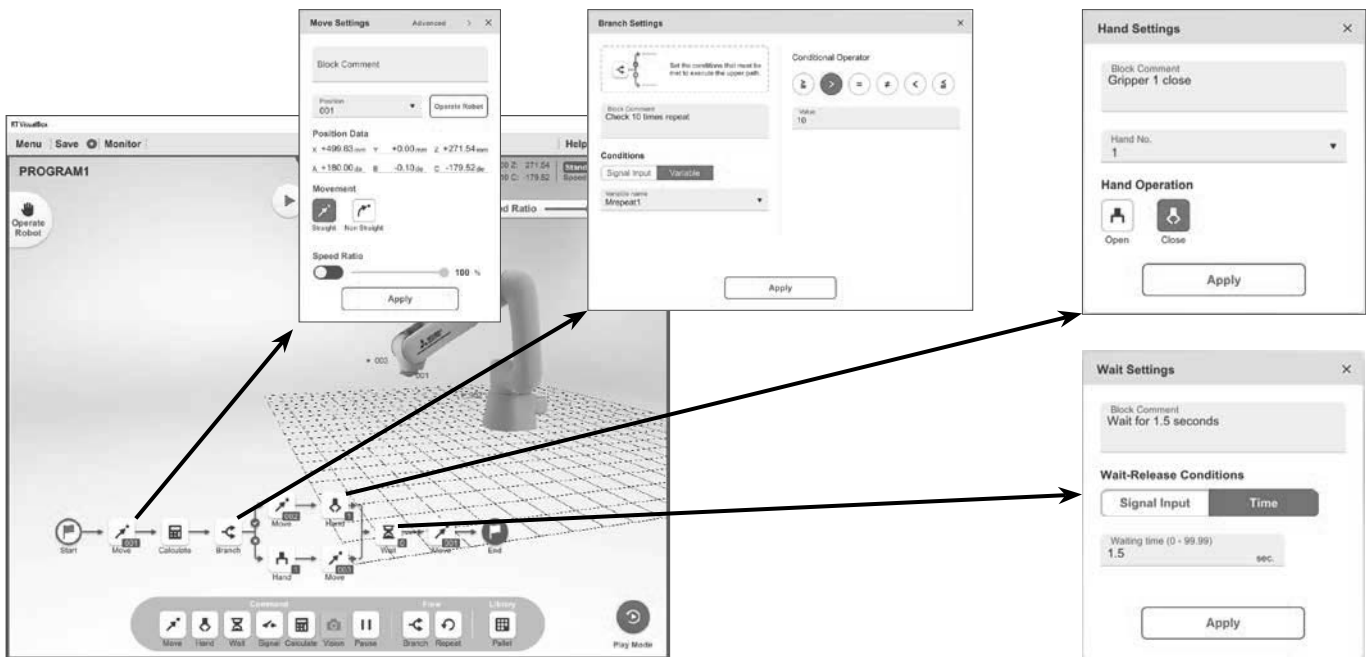



**A****Accessories**

Batteries .....	54
Bellows .....	50
Connection cables for PCs and inputs/outputs, connectors .....	54
Connectors .....	52
Controller protection box .....	54
Force sensor .....	47
Gripper signal cables .....	52
Hand curl tube .....	53
Interface boards .....	51
Machine cables for robots and controllers .....	53
MELFA SafePlus .....	47
MELFA Smart Plus Card and MELFA Smart Plus card pack .....	48
Solenoid valve sets .....	50
Teaching box .....	46
Wiring .....	49

**Articulated arm robots**

RV-2FR(B)/RV-2FRL(B) .....	19
RV-4FRLM .....	21
RV-7FRM/7FRLM/7FRLLM .....	23
RV-8CRL .....	31
RV-13FRM/RV-13FRLM/RV-20FRM .....	25
RV-35F/RV-50F/RV-70F .....	27

**C****Collaborative robots**

RV-5AS-D .....	29
----------------	----

**Controller .....** 44**D****Delta robots**

RD-1F500/RD-1F800/RD-1F1100/RD-1F1300 .....	42
---	----

**Dimensions**

Controller .....	45
RH-1FRHR .....	34
RH-3FRHR .....	36
RH-CRH .....	41
RH-FRH .....	38
RV-2FR(L)(B) .....	20
RV-4FRLM .....	22
RV-5AS-D .....	30
RV-7FRM/7FRLM/7FRLLM .....	24
RV-8CRL .....	32
RV-13FRM/RV-13FRLM/RV-20FRM .....	26
RV-35F/RV-50F/RV-70F .....	28

**M****Movement ranges**

RH-1FRHR .....	34
RH-3FRHR .....	36
RH-CRH .....	41
RH-FRH .....	38
RV-2FR(L)(B) .....	20
RV-4FRLM .....	22
RV-5AS-D .....	30
RV-7FRM/7FRLM/7FRLLM .....	24
RV-8CRL .....	32
RV-13FRM/RV-13FRLM/RV-20FRM .....	26
RV-35F/RV-50F/RV-70F .....	28

**O****Options overview for all robots .....** 55**Overview robots**

Horizontal, multiple-joint type (RH) .....	4
Mitsubishi Electric collaborative robot "ASSISTA" .....	6
Model designation .....	7, 8
Vertical, multiple-joint type (RV) .....	4

**P****Programming language**

MELFA-BASIC programming .....	57
-------------------------------	----

**S****SCARA robots**

RH-1FRHR .....	33
RH-3FRHR .....	35
RH-CRH .....	40
RH-FRH .....	37

**Software**

RT ToolBox3 .....	58
RT ToolBox3 Pro .....	59
RT VisualBox .....	60

**Standard high end functions**

Adaptation to operation .....	11
CC-Link IE Field Network Basic function .....	13
Collision avoidance .....	13
Connection to peripheral devices .....	12
Coordinated control .....	13
Full use of installation space .....	9
GOT terminals .....	18
High accuracy .....	11
Intelligent technology .....	14
iQ Platform .....	18
MELFA SafePlus features .....	17
Predictive maintenance function .....	15
Shortened takt times .....	9
Tooling performance .....	9
User friendliness .....	10

**System configuration .....** 43



# Your solution partner

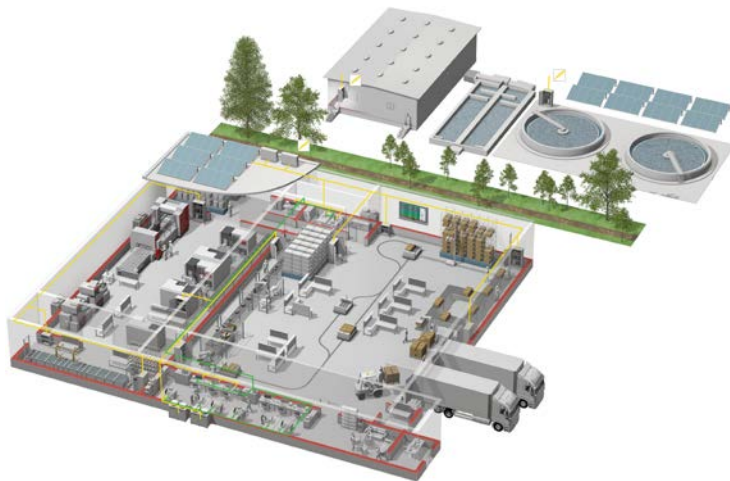

Mitsubishi Electric offers a wide range of automation equipment from PLCs and HMIs to CNC and EDM machines

## A name to trust

Since its beginnings in 1870, some 45 companies use the Mitsubishi name, covering a spectrum of finance, commerce and industry.

The Mitsubishi brand name is recognized around the world as a symbol of premium quality.

Mitsubishi Electric Corporation is active in space development, transportation, semi-conductors, energy systems, communications and information processing, audio visual equipment and home electronics, building and energy management and automation systems, and has 237 factories and laboratories worldwide in over 121 countries.

This is why you can rely on Mitsubishi Electric automation solution - because we know first hand about the need for reliable, efficient, easy-to-use automation and control in our own factories.

As one of the world's leading companies with a global turnover of over 4 trillion Yen (over \$40 billion), employing over 130,000 people, Mitsubishi Electric has the resource and the commitment to deliver the ultimate in service and support as well as the best products.



Low voltage: MCCB, MCB, ACB



Medium voltage: VCB, VCC



Power monitoring, energy management



Compact and modular controllers



Inverters, servos and motors



Visualization: HMIs, software, MES connectivity



Numerical control (NC)



Robots: SCARA, articulated arm, cobots



Processing machines: EDM, lasers, IDS



Air-conditioning, photovoltaic, EDS

# Global Partner. Local Friend.

## European Offices

<b>Germany</b> <b>Mitsubishi Electric Europe B.V.</b> Mitsubishi-Electric-Platz 1 D-40882 Ratingen Phone: +49 (0)2102 / 486-2048	<b>Czech Rep.</b> <b>Mitsubishi Electric Europe B.V.</b> Pekařská 621/7 CZ-155 00 Praha 5 Phone: +420 734 402 587	<b>France</b> <b>Mitsubishi Electric Europe B.V.</b> 25, Boulevard des Bouvets F-92741 Nanterre Cedex Phone: +33 (0)1 / 55 68 56 95	<b>Ireland</b> <b>Mitsubishi Electric Europe B.V.</b> Westgate Business Park, Ballymount IRL-Dublin 24 Phone: +353 (0)1 4198800	<b>Italy</b> <b>Mitsubishi Electric Europe B.V.</b> Viale Colleoni 7 Palazzo Sirio I-20864 Agrate Brianza (MB) Phone: +39 039 / 60 53 1	<b>Netherlands</b> <b>Mitsubishi Electric Europe B.V.</b> Nijverheidsweg 23A NL-3641RP Mijdrecht Phone: +31 (0) 297 250 350	<b>Poland</b> <b>Mitsubishi Electric Europe B.V.</b> ul. Krakowska 48 PL-32-083 Balice Phone: +48 (0) 12 347 65 00
<b>Russia</b> <b>Mitsubishi Electric (Russia) LLC</b> 2 bld. 1, Letnikovskaya st. RU-115114 Moscow Phone: +7 495 / 721 2070	<b>Spain</b> <b>Mitsubishi Electric Europe B.V.</b> Carretera de Rubi 76-80 Apdo. 420 E-08190 Sant Cugat del Vallés (Barcelona) Phone: +34 (0) 93 / 5653131	<b>Sweden</b> <b>Mitsubishi Electric Europe B.V.</b> (Scandinavia) Hedvig Möllens gata 6 SE-223 55 Lund Phone: +46 (0) 8 625 10 00	<b>Turkey</b> <b>Mitsubishi Electric Turkey Elektrik Ürünleri A.Ş.</b> Şerifali Mahallesi Kale Sokak No:41 TR-34775 Ümraniye-İSTANBUL Phone: +90 (216) 569 25 00	<b>UK</b> <b>Mitsubishi Electric Europe B.V.</b> Travellers Lane UK-Hatfield, Herts. AL10 8XB Phone: +44 (0)1707 / 28 87 80		

## Representatives

<b>Austria</b> <b>GEVA</b> Wiener Straße 89 A-2500 Baden Phone: +43 (0)2252 / 85 55 20	<b>Belarus</b> <b>OOO TECHNIKON</b> Prospekt Nezavisimosti 177-9 BY-220125 Minsk Phone: +375 (0)17 / 393 1177	<b>Bosnia and Herzegovina</b> <b>INEA RBT d.o.o.</b> Stegne 11 SI-1000 Ljubljana Phone: +386 (0)1 / 513 8116	<b>Bulgaria</b> <b>AKHINATON</b> 4, Andrei Lipchev Blvd., PO Box 21 BG-1756 Sofia Phone: +359 (0)2 / 817 6000	<b>Croatia</b> <b>INEA CR</b> Losipjka 4 a HR-10000 Zagreb Phone: +385 (0)1 / 36 940 -01/-02/-03	<b>Czech Republic</b> <b>SIMAP CZ s.r.o.</b> Nové sady 958/2 CZ-602 00 Brno Phone: +420 777 731 900	<b>Denmark</b> <b>HANS FOLSGAARD A/S</b> Theilgaardsgårds Torv 1 DK-4600 Køge Phone: +45 4320 8600
<b>Estonia</b> <b>Electrobit OÜ</b> Pärnu mnt. 160i EST-11317, Tallinn Phone: +372 6518 140	<b>Finland</b> <b>UTU Automation Oy</b> Peltoie 37 FIN-28400 Ulvila Phone: +358 (0)207 / 463 500	<b>Greece</b> <b>UTECO A.B.E.E.</b> 5, Mavrogenous Str. GR-18542 Piraeus Phone: +30 (0)211 / 1206-900	<b>Hungary</b> <b>MELTRADE Kft.</b> Fertő utca 14, HU-1107 Budapest Phone: +36 (0)1 / 431-9726	<b>Latvia</b> <b>OAK Integrator Products SIA</b> Ritausmas iela 23 LV-1058 Riga Phone: +371 67842280	<b>Malta</b> <b>ALFATRADE Ltd.</b> 99, Paola Hill Malta-Paola PLA 1702 Phone: +356 (0)21 / 697 816	<b>Portugal</b> <b>Fonseca S.A.</b> R. João Francisco do Casal 87/89 PT-3801-997 Aveiro, Esqueira Phone: +351 (0)234 / 303 900
<b>Romania</b> <b>Sirius Trading &amp; Services</b> Aleea Lacul Morii Nr. 3 RO-060841 Bucuresti, Sector 6 Phone: +40 (0)21 / 430 40 06	<b>Serbia</b> <b>INEA SR d.o.o.</b> Ul. Karadjordjeva 12/217 SER-11300 Smederevo Phone: +381 69 172 27 25	<b>Slovakia</b> <b>SIMAP SK</b> Dolná Pažiťe 603/97 SK-911 06 Trenčín Phone: +421 (0)52 743 04 72	<b>Slovenia</b> <b>INEA RBT d.o.o.</b> Stegne 11 SI-1000 Ljubljana Phone: +386 (0)1 / 513 8116	<b>Switzerland</b> <b>Robotronic AG</b> Riedhofstrasse 65 CH-8408 Winterthur Phone: +41 52 267 02 00	<b>Ukraine</b> <b>CSC- AUTOMATION Ltd.</b> 4 B, Yevhena Sverstyuksa Str. UA-02002 Kiev Phone: +380 (0)44 / 494 33 44	
<b>Egypt</b> <b>EIM Energy</b> 3 Romy Square ET-11341 Heliopolis, Cairo Phone: +202 24552559	<b>Israel</b> <b>ILAN &amp; GAVISH Ltd.</b> 24 Shenkar St., Kiryat Arne IL-49001 Petah Tikva Phone: +972 (0)3 / 922 18 24	<b>South Africa</b> <b>ADROIT TECHNOLOGIES</b> 20 Waterford Office Park 189 Wilkoppen Road ZA-Fourways Phone: +27 (0)11 / 658 8100				



version direct

Mitsubishi Electric Europe B.V. / FA - European Business Group / Mitsubishi-Electric-Platz 1 / D-40882 Ratingen / Germany /  
 Tel.: +49(0)2102-4860 / Fax: +49(0)2102-4861120 / info@mitsubishi-automation.com / https://eu3a.mitsubishielectric.com

Art. no. 203684-K / 12.2021 / Specifications subject to change / All trademarks and copyrights acknowledged.