

FACTORY AUTOMATION

MELFA FAMILY

Industrial robots



- **Collaborative robots**
- **Vertical/Horizontal articulated robots**
- **High-performance controllers**
- **Programming software**
- **Simulation**



Automating the World



Our Factory Automation business is focused on "Automating the World" to make it a better, more sustainable environment supporting manufacturing and society, celebrating diversity and contributing towards an active and fulfilling role.

Mitsubishi Electric is involved in many areas including the following:

Energy and Electric Systems

A wide range of power and electrical products from generators to large-scale displays.

Electronic Devices

A wide portfolio of cutting-edge semiconductor devices for systems and products.

Home Appliance

Dependable consumer products like air conditioners and home entertainment systems.

Information and Communication Systems

Commercial and consumer-centric equipment, products and systems.





Industrial Automation Systems

Maximizing productivity and efficiency with cutting-edge automation technology.

SUSTAINABLE DEVELOPMENT GOALS

The Mitsubishi Electric Group is actively solving social issues, such as decarbonization and labor shortages, by providing production sites with energy-saving equipment and solutions that utilize automation systems, thereby helping towards a sustainable society.

Contents

Features in detail	4-5	
Work alongside human operators	6-7	
Precision and flexibility	8-9	
The technology in detail	10-11	
Software for industrial robots	12	

Technical information

Features in detail

Robots from € 1.65/hr

Calculated on the basis of their average service life, around 6–7 years in typical applications, Mitsubishi Electric robots have a surprisingly low total cost of ownership at around € 1.65 per hour for both purchasing and operation.



Versatility

Small robots have been used in more than 100,000 applications in widely differing fields since 1978 – and what is more they work around the clock, 24 hours a day, 7 days a week.

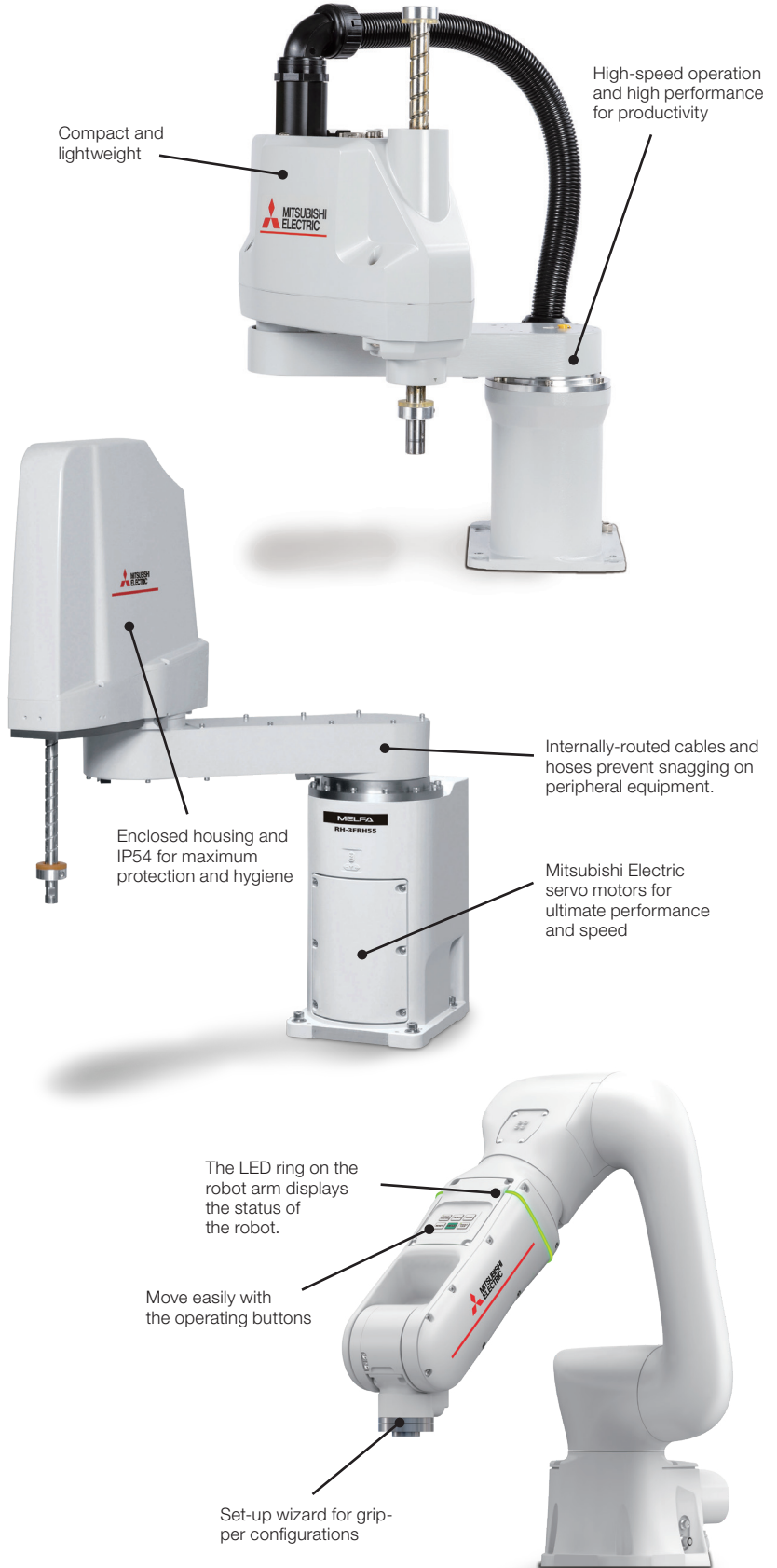

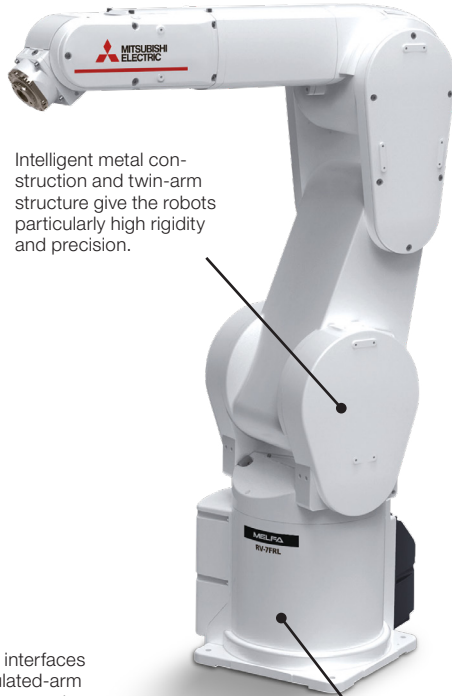

Intelligent metal construction and twin-arm structure give the robots particularly high rigidity and precision.

The gripper interfaces of the articulated-arm robots conform to the ISO 9409-1 standard.

Mitsubishi Electric servo motors of the latest generation help to provide exceptional repeatability performance.



A very compact design takes up minimum space for applications in cramped quarters.

Simple programming

A powerful range of robots needs an equally powerful and user-friendly programming interface. Mitsubishi Electric's RT ToolBox3 is a powerful programming and simulation software tool tailored precisely for the needs of your robots.



Network capabilities

Network connections like Ethernet, Profibus, PROFINET, EtherCAT, DeviceNet® and CC-Link make it easy to integrate Mitsubishi Electric robot controllers in to larger systems, providing users with access to every step of the process. Also you can connect the robot via OPC UA standard.



Work alongside human operators

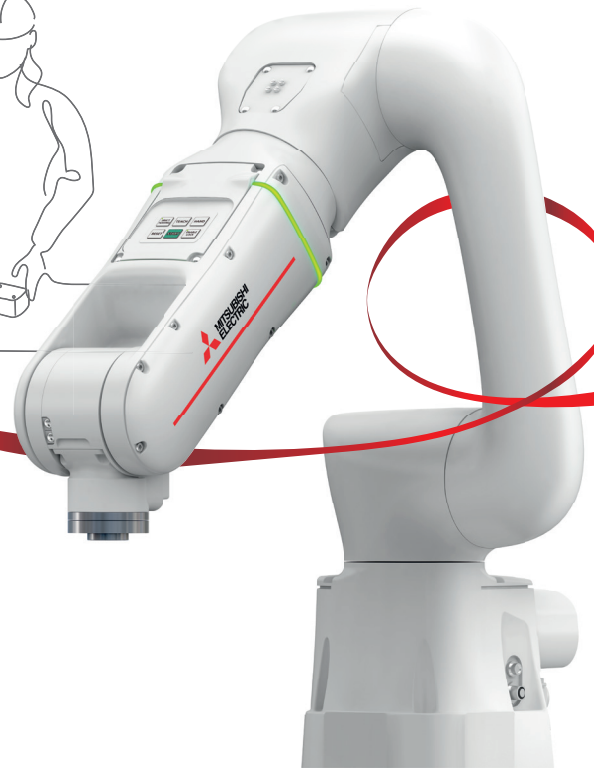
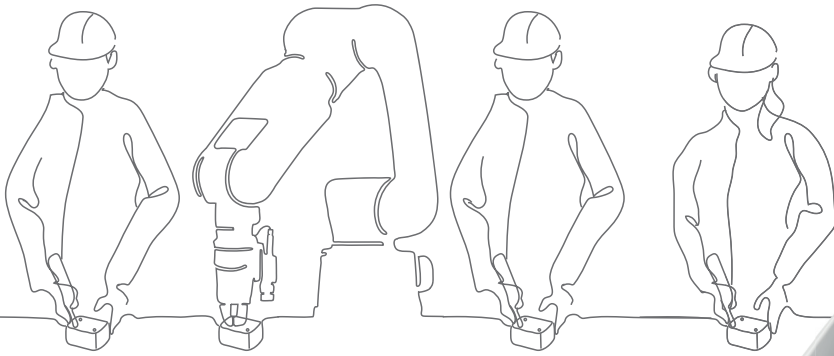

MELFA

assist^a

Integrate. Collaborate.

Mitsubishi Electric's collaborative robot, the MELFA ASSISTA, has been developed to work alongside human operators without the need for guards or safety fences, while meeting new requirements for adequate distancing of workers in manufacturing sites. The cobot offers maximum safety, such as collision detection and strict compliance with the international safety and robotic standards ISO 10218-1 and ISO/TS15066. Furthermore, it offers durability combined with ease of use and programming, while maintaining very high positional repeatability of ± 0.03 mm* by a rated payload of 5 kg and reach radius of 910 mm.

* Commonly offered repeat accuracy by cobots of ± 0.1 mm.

Easy control

Fast and intuitive robot setup via dedicated control panel

Robot movements can be taught and recorded quickly via a dedicated control panel on the cobot arm, doing away with separate teaching boxes required for conventional industrial robots.

The control panel features a simple design with a minimum number of buttons for simplicity, enabling even inexperienced users without expert knowledge of robots to set up the system with ease.

A bright, always visible 6 colour LED ring mounted around the robot's forearm clearly displays the status of the robot.

Easy programming

Simplified application development using intuitive flow-chart programming

The RT VisualBox programming tool developed by Mitsubishi Electric enables operating sequences to be created intuitively by linking block diagrams in a chain of events, including connection with other devices such as robot hands and cameras. Fast program-development and design time help to reduce system TCO.

Easy connecting

A wide variety of components and applications

ASSISTA offers a wide variety of components – grippers, fingers, vision and other peripherals – developed by a group of organizations known as MELFA robot partners.

These tools can easily be setup and configured for your application.

ASSISTA can also be configured to move freely as part of an AGV/AMR* or as a mobile robot.

* AGV: Automated Guided Vehicle
AMR: Autonomous Mobile Robot

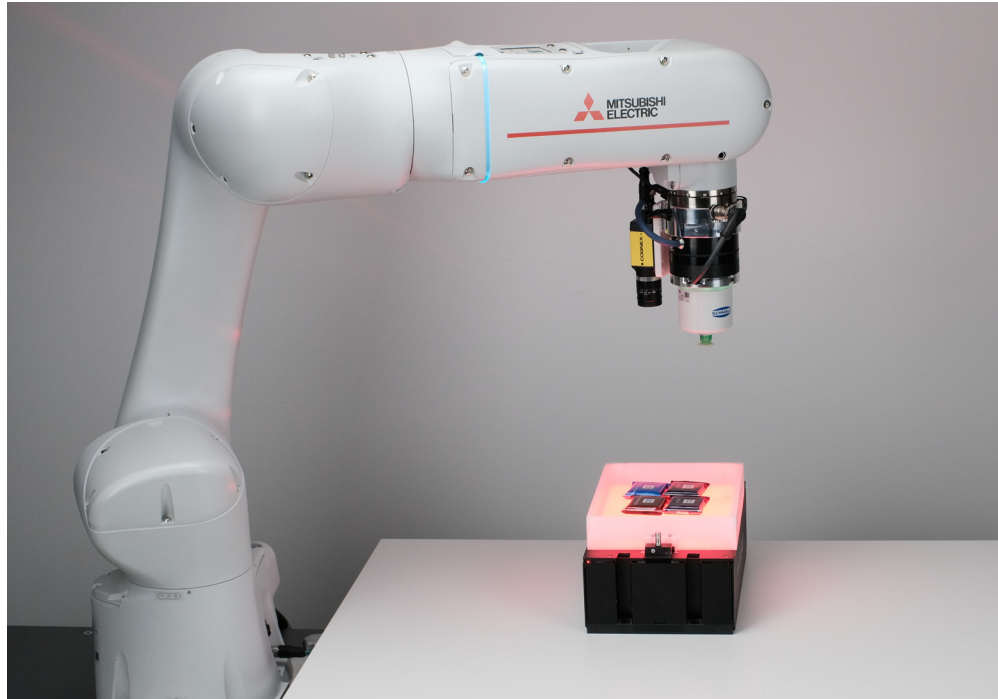

Grip with ASSISTA

Simply connect grippers to robot arm

The ASSISTA set-up wizard provides operators with an easier more intuitive methodology for gripper configurations.

View with ASSISTA

“RT VisualBox” proprietary engineering tool

The vision camera focus adjustment and work registration can be configured simply by touching the screen. This means that you can use it even without special robot knowledge.



Precision and flexibility

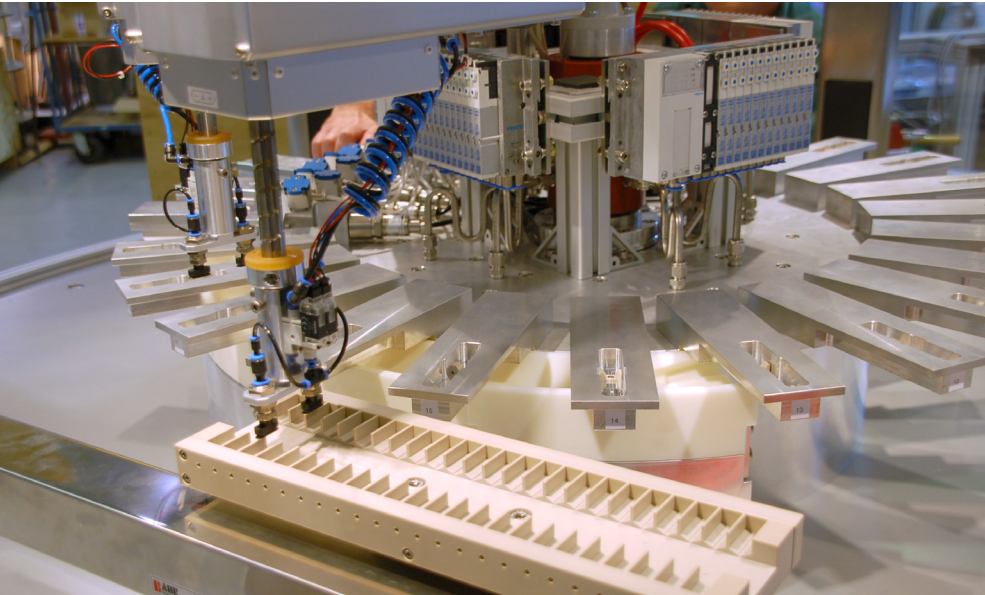

Pharmaceutical industry

Modular control concepts and pharmaceutical industry certification make MELFA robots the ideal partner in the life sciences sector. Integral database connection and an all-embracing control concept facilitate modular and flexible applications in any field where quality and production data have to be backed up in a comprehensible manner.



Food and drink

Increasing hygiene demands, a variety of products and the traceability of production processes are ensured with MELFA robots – now and in the future.

Innovative details and stringent guidelines for MELFA robots guarantee assured quality even in ultra-clean applications.

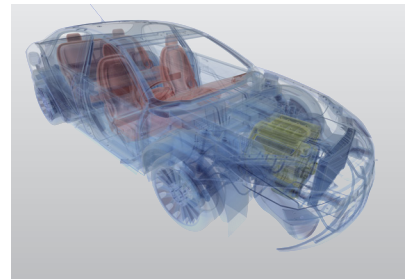

Automotive industry

Highly accurate and extremely flexible MELFA robots are used whenever every little detail matters – haptic measurement, quality assurance and assembly of complex components. MELFA robots carry out their tasks around the clock and at full speed.

Packaging

High-performance and flexibility are a matter of course for MELFA robots. It goes equally without saying that all Mitsubishi Electric automation components can be incorporated. These include additional axes, PLC controllers and operating terminals. Furthermore, cameras can be connected and robots synchronised with conveyor belts. These functions enable packaging tasks to be carried out reliably, quickly and continuously.

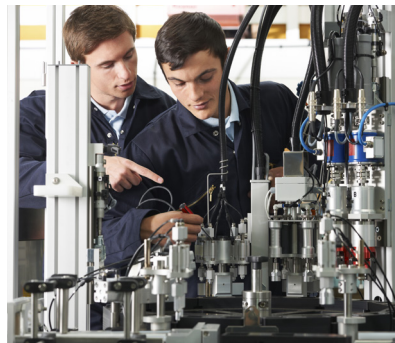
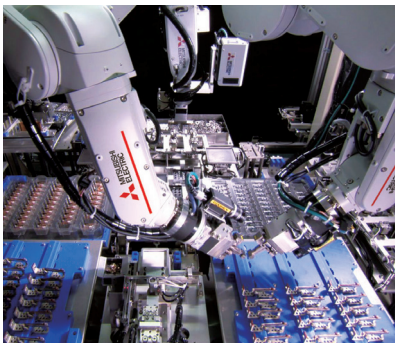
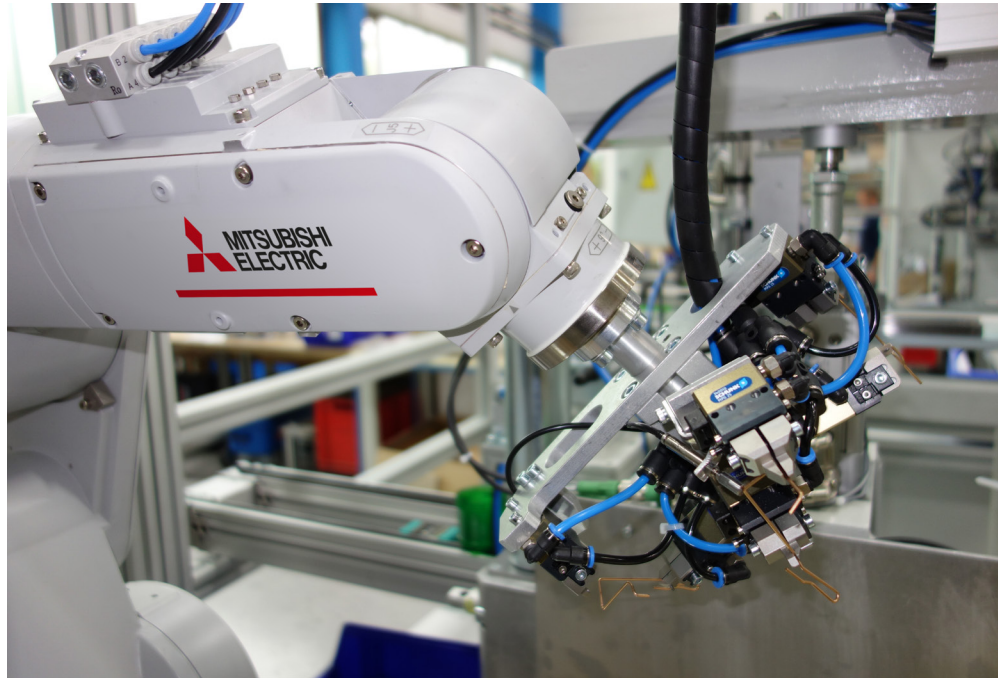

Electronics and mechanical engineering

Mitsubishi Electric provides a wide range of products from SCARA robots for the micro assembly of miniature components to fully sealed articulated arm robots. There are no applications which are not suitable for MELFA robots. Whether clean-room or dirty, oily and dusty environments, the product range always includes the right robot for your application.

Training

Learning from practical experience – a goal which can be achieved in a training environment with the compact, lightweight MELFA robots. Simple programming, simulation options and experienced teachers make entry into the field of robotics easy.

No limits – thanks to standard real-time interfaces and simple programming, MELFA robots provide all sorts of options for using the robots as manipulators, even for complex university research projects.

The technology in detail



ognition camera system via the Gigabit Ethernet interface of the robot controller. This enables static and moving parts to be detected with the correct positional information.

The possible uses of sensor-controlled robots in factory automation are manifold. They range from component assembly via quality control and the reworking of workpieces to the location and removal of objects from a conveyor belt.

FR-R series – full PLC functionality in the robot

As robots are never installed on a stand-alone basis, the system must be easy to integrate into its working environment to enable it to communicate with PLC and motion systems as well as operating panels and other systems. Together with the modular robot CPU, the Mitsubishi Electric iQ Platform provides the ideal basis for integrating the full functionality of a PLC into the robot controller – once again demonstrating the company’s role as a pioneer in automation technology.

More safety

The DIN ISO-10218 safety standard is common to all robots and therefore guarantees safe operation in all applications. Mitsubishi Electric’s supplementary product range including safety controllers enables the robots to be integrated into a common safety concept. Ready-made example projects make it possible for anyone to put together even complex systems quickly and effectively.

The optional “MELFA SafePlus” safety technology for the FR series robot controllers has functions available like reduced safe speed control, safe limited control range and safe torque monitoring, which can be activated via safety inputs. Logic for each safe I/O can be edited and in combination with the position monitoring function a safe system can be constructed without using a Safety PLC.

Based on these functions, saving of safety equipment and a reduction of safeguarded space is possible which leads to a reduction of cost and space while meeting all safety requirements at the same time.

Sensor-controlled robots with image processing

Mitsubishi Electric’s industrial robots can be connected to any object rec-

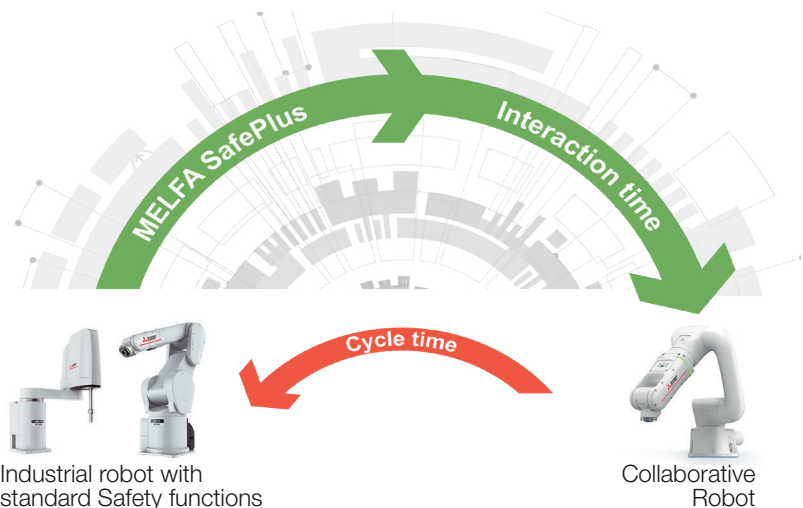

Simple integration into complex applications

Up to eight additional axes can be connected directly to the robot controller with just one cable. Of these, two axes can be used as additional interpolating axes, e.g. as the seventh and eighth robot axis.

The special feature compared with other systems is that all additionally connected axes can be programmed in exactly the same way as the robot, using the same Teaching-Box or the standard RT ToolBox3 software. This avoids the additional expense of software, training and programming.

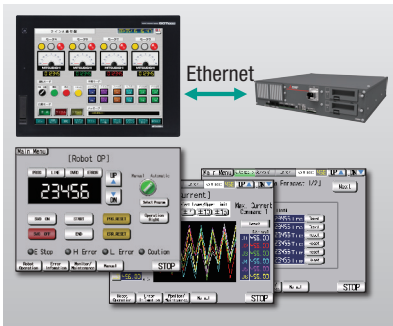
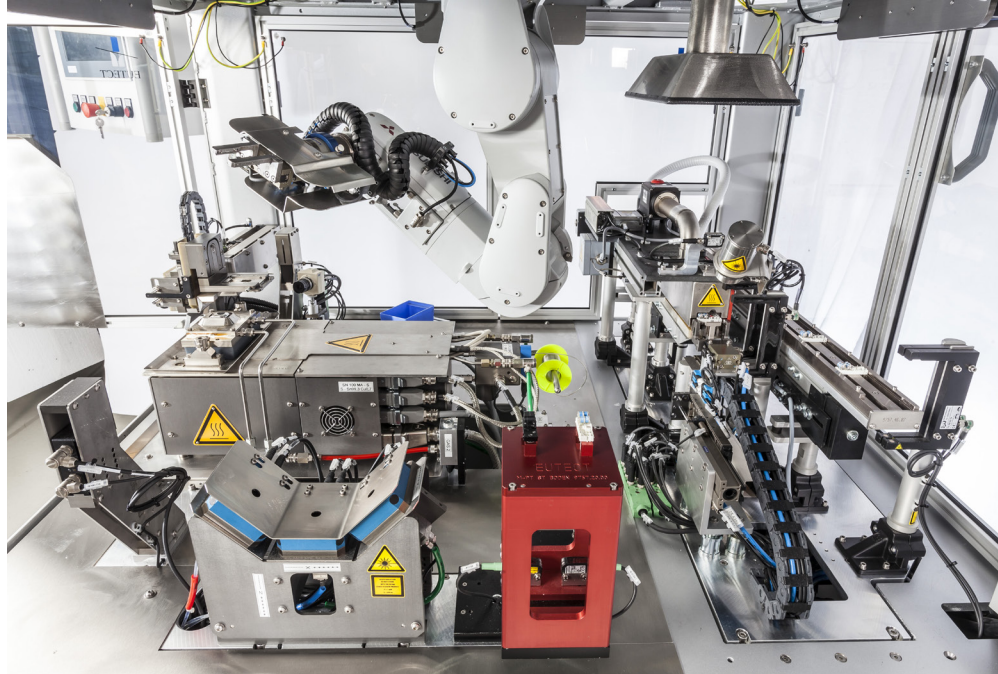

More efficient monitoring and maintenance functions

Direct connection of the company's infrastructure GOT operating terminal via Ethernet opens up a number of monitoring, control and maintenance functions for the robot. The correction of taught points, the backup and restore function, the entry of production data, and the selection and control of processes are just some of the options provided by the Mitsubishi Electric operating terminal in conjunction with MELFA robots.

Open communication for PC connection

The robot controller can be connected to an MES system, for example for easily and quickly changing manufacturing sequences without stopping production.

Furthermore, the robot can be initiated for any kind of movement in real time. Flexible and complex movements, which are generated graphically on the PC, for example, can be realised in this way.

Programming and simulation

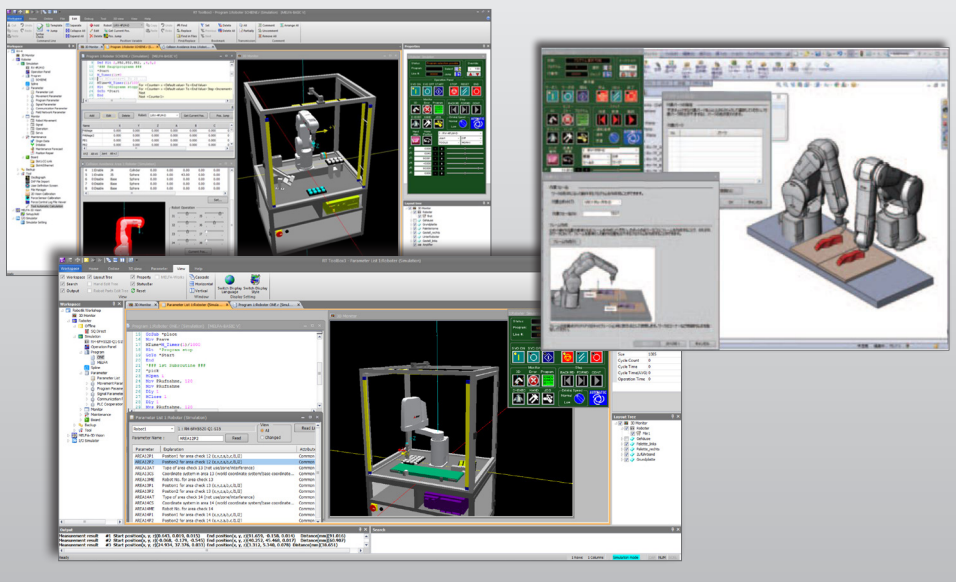

Simulation of a Mitsubishi Electric industrial robot directly in an application

- The CAD data of the system can be directly imported
- Grippers can be connected directly to the robot
- Handling of workpieces
- Offline teaching in a 3D environment
- Creation of robot programs
- Collision-checking between robot and system environment

RT VisualBox

The RT VisualBox programming tool is an intuitive engineering software for MELFA ASSISTA for quick, easy system deployment. It enables operating sequences to be created intuitively by linking block diagrams in a chain of events, including connection with other devices such as robot hands and cameras.

The convenient operating terminal for mobile teaching

The R86TB is a powerful operating panel for carrying out all tasks directly at the robot, from controlling the robot and displaying the loads by means of the input/output display to complete program creation and parameterisation. The comprehensive functions ensure optimum utilisation of the robot system and thus reduce setup times.

The integral USB port enables data to be exchanged conveniently, and complete controller backups can be uploaded and downloaded through a memory stick.



High-performance industrial robots also require high-performance software. For this reason, more and more automation engineers are opting for the versatile and convenient Mitsubishi Electric software. All tasks, such as the creation of projects, programming and simulation, are implemented intuitively and mesh perfectly with one another. This results in optimum movement sequences in the shortest possible installation and commissioning time.

Programming

Offline and online programming with simulation.

Simulation

3D-CAD import and up to 16 robots can be simulated in one project; additional axes can be connected and positions taught directly in the simulation.

Parameters

Parameter structure for the simple parameterisation of functions; complete overview of all parameters with display of modified values only.

Maintenance

Full backup and restore function and monitoring of service intervals, production runtimes and product cycles.

Monitoring

Display of load currents, position values, variables and variable positions. Monitoring of switching signals, program execution and fault history.

Documentation

Full project documentation with output of modified parameters, program code and positions.

3D-simulation with RT ToolBox3 Pro

The RT ToolBox3 Pro add-in tool for SolidWorks enables MELFA robots to be simulated in the CAD environment on a PC, and converts the workpiece paths into robot position data.

Supplementing the SolidWorks platform by the addition of RT ToolBox3 Pro extends the simulation functions and opens up new simulation possibilities.

Technical Information Section

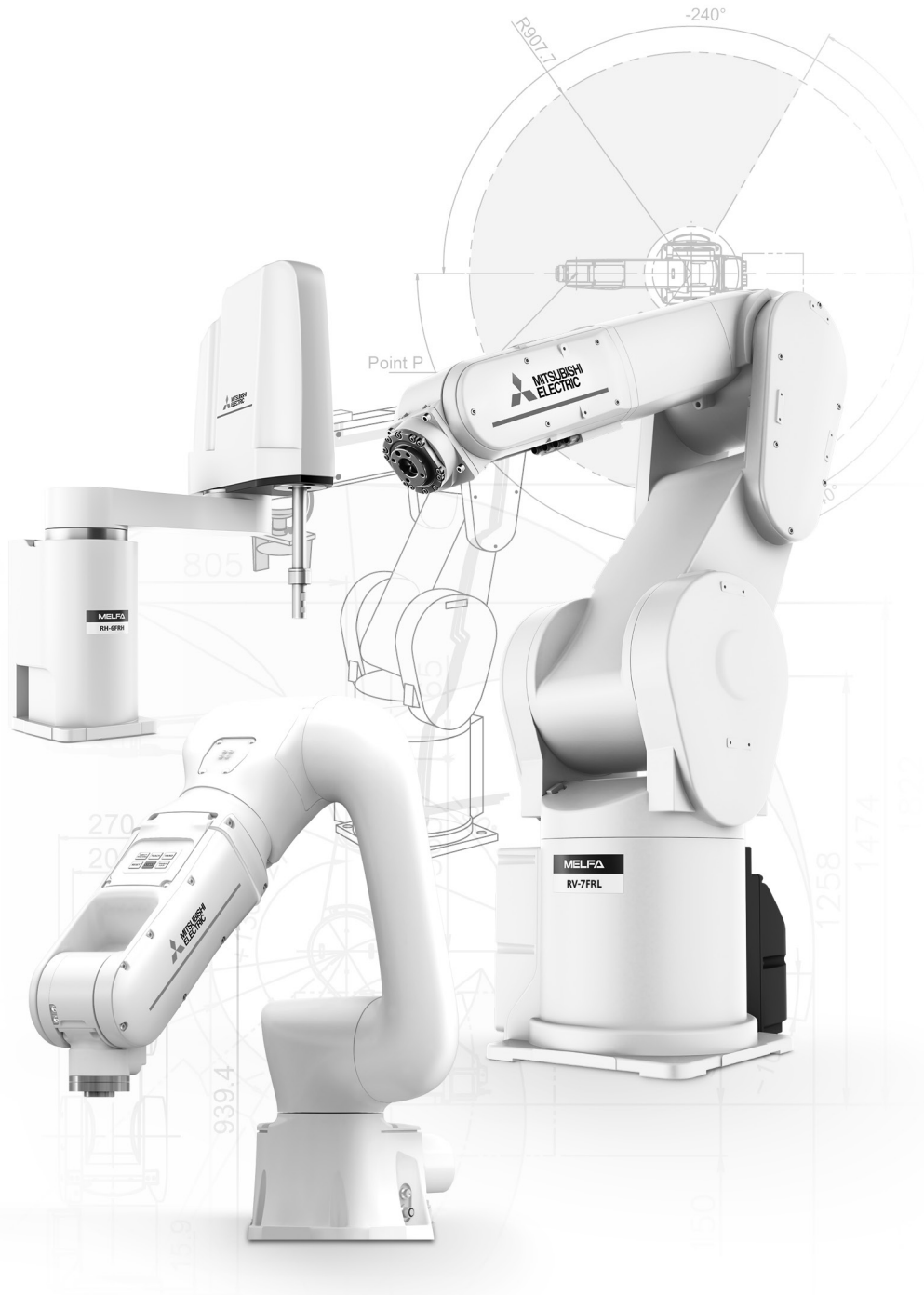

Further service supplies

This product catalogue is designed to give an overview of the extensive range of Mitsubishi Electric MELFA RV and RH series. If you cannot find the information you require in this catalogue, there are a number of ways you can get further details on configuration and technical issues, pricing and availability.

For technical issues visit the <https://emea.mitsubishielectric.com/fa> website. Our website provides a simple and fast way of accessing further technical data and up to the minute details on our products and services. Manuals and catalogues are available in several different languages and can be downloaded for free.

For technical, configuration, pricing and availability issues contact our distributors and partners. Mitsubishi Electric partners and distributors are only too happy to help answer your technical questions or help with configuration building. For a list of Mitsubishi Electric partners please see the back of this catalogue or alternatively take a look at the “contact us” section of our website.

About this product catalogue

This catalogue is a guide to the range of products available. For detailed configuration rules, system building, installation and configuration the associated product manuals must be read. You must satisfy yourself that any system you design with the products in this catalogue is fit for purpose, meets your requires and conforms to the product configuration rules as defined in the product manuals.

Specifications are subject to change without notice. All trademarks acknowledged. © Mitsubishi Electric Europe B.V., Factory.

The products of Mitsubishi Electric Europe B.V., that are listed and described in this document, are neither subject to approval for export nor subject to the Dual-Use List.

Contents



1 Robots

- Overview robots 16
- Standard high end functions 22
- Industrial robots RV-2FR(L)(B) 32
- Industrial robots RV-4FRLM 34
- Industrial robots RV-7FRM/7FRLM/7FRLLM 36
- Industrial robots RV-13FRM/RV-13FRLM/RV-20FRM 38
- Industrial robots RV-35/50/80FR 40
- Industrial robots RV-5AS 42
- Industrial robots RV-8CRL/RV-12CRL 44
- Industrial robots RH-1FRHR 46
- Industrial robots RH-3FRHR 48
- Industrial robots RH-FRH 50
- Industrial robots RH-CRH 53
- System overview 56

2 Controller

- Controller 57
- Dimensions of the control units 58

3 Accessories

- Teaching box 60
- Force sensor, MELFA SafePlus 61
- MELFA Smart Plus card, MELFA Smart Plus card pack 62
- Wiring set 63
- Valve sets, bellows 64
- Interface boards 65
- Adaptor cables, connectors 66
- Tubes, extension cables 67
- PC and I/O connection cables, controller protection box, buffer batteries 68
- General overview of options 69

4 Programming language

- MELFA-BASIC 71

5 Software

- RT Toolbox3 72
- RT Toolbox3 Pro 73
- RT VisualBox 74

- Index 75

A complete lineup

Large range of robot models makes selection easy

Mitsubishi Electric produces a comprehensive range of robot models to cater to the full spectrum of modern needs. All Mitsubishi Electric robots are powerful, fast and compact – that goes almost without saying.

The product range includes the almost universal articulated-arm robots with 6 degrees of freedom and payloads of 2 kg to 80 kg and SCARA robots with 4 degrees of freedom and payloads of 3 kg to 20 kg for assembly and palletising tasks.

Three special models are available, the unique collaborative robot MELFA ASSISTA with a payload of 5 kg, which can share a workspace with humans, the cost effective models RV-8CRL and RV-12CRL as well as the flexible high-speed SCARA robots for ceiling mounting.

Vertical, multiple-joint type (RV)



Model	RV-2FR(B)	RV-2FRL(B)	RV-4FRL	RV-7FR	RV-7FRL	RV-7FRL
R. accuracy (mm)	± 0.02	± 0.02	± 0.02	± 0.02	± 0.02	± 0.06
Load capacity (kg)	2	2	4	7	7	7
Reach (mm)	504	648	649	713	908	1503
IP class	IP30	IP30	IP40/(M)IP67	IP40/(M)IP67	IP40/(M)IP67	IP40/(M)IP67
ISO 14644-1 (full load)	8	—	7	7	5	5
Clean Room Design	—	—	ISO class 3	ISO class 3	ISO class 3	ISO class 3
Special Version	—	—	ESD/ATEX	ESD/ATEX	ESD/ATEX	ESD/ATEX



Controller CR800-D/CR800-R + R16RTCPU

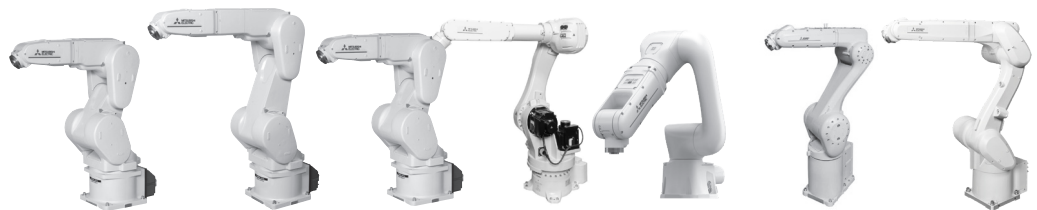

Model	RV-13FR	RV-13FRL	RV-20FR	RV-35/50/80FR	RV-5AS	RV-8CRL	RV-12CRL
R. accuracy (mm)	± 0.05	± 0.05	± 0.05	± 0.06	± 0.03	± 0.02	± 0.04
Load capacity (kg)	13	13	20	35/50/80	5	8	12
Reach (mm)	1094	1388	1094	2100	916	931	1504
IP class	IP40/(M)IP67	IP40/(M)IP67	IP40/(M)IP67	IP65/(M)IP67	IP54	IP65	IP65
ISO 14644-1 (full load)	7	7	5	—	5	6	—
Clean Room Design	ISO class 3	ISO class 3	ISO class 3	—	ISO class 5	—	—
Special Version	ESD/ATEX	ESD/ATEX	ESD/ATEX	—	ESD/Food grade H1 grease	—	—



Controller CR800-D/CR800-R + R16RTCPU CR860-D/CR860-R + R16RTCPU CR800-D

Overview robots

Advanced intelligence, safety and integration

The concept of FR robots offers a simple approach to advanced and flexible production to handle all automation needs. This concept is based on 3 key features.

- **Intelligence:** “MELFA Smart Plus” offers greater accuracy and shorter startup times, making installation simpler and more advanced tasks possible.
- **Safety:** A comprehensive range of safety functions, including position and speed monitoring, allow work to be conducted in cooperation with people.
- **Integration:** MELSEC iQ-R compatible robot controller and the e-F@ctory integrated FA solution offers seamless integration of robots and IT systems.

Horizontal articulated robots (RH)



Model	RH-1FRHR	RH-3FRHR	RH-3FRH5515N	RH-6FRH5520N	RH-12FRH8535N	RH-20FRH10035N
R. accuracy (mm)	± 0.02	± 0.02	± 0.02	± 0.02	± 0.02	± 0.02
Load capacity (kg)	1	3	3	6	12	20
Reach (mm)	550	700	550	550	850	1000
IP class	IP20/(IP65)	IP20/(IP65)	IP20	IP54/(IP65)	IP54/(IP65)	IP54/(IP65)
ISO 14644-1 (With/without bellows)	—	—	—	5/7	5/-	5/7
Clean Room Design	ISO class 5	ISO class 5	ISO class 3	ISO class 3	ISO class 3	ISO class 3
Special version	—	ESD	ESD	ESD	ESD	ESD



Controller CR800-D/CR800-R + R16RTCPU



Model	RH-3CRH	RH-6CRH	RH-10CRH	RH-20CRH
R. accuracy (mm)	± 0.01	± 0.02		
Load capacity (kg)	3	6	10	20
Reach (mm)	400	600/700	600/700/800	850/1000
IP class	IP20	IP20	IP20	IP20
ISO 14644-1 (full load)	—	—	—	—
Clean Room Design	—	—	—	—
Special version	—	—	—	—



Controller CR800-D

Mitsubishi Electric collaborative robot "ASSISTA"

Simpler and easier

- Robots work with people and work next to people in busy workplaces.
- Simpler, easier and more flexible.
- It is a robot for you that changes the image of the robot.

Easy control

- The operating buttons on the robot arm provide you with easy control for ASSISTA and the teaching pendant for programming and teaching is no longer needed.
- The LED on the robot arm display the status of the robot.

Easy programming

- You can create programs visually using intuitive operations with RT VisualBox.
- "Visual programming" – This software allows operators to simply program this robot with a "train by demonstration" programming interface.

Grip with ASSISTA

Simply connect grippers to robot arm

The ASSISTA set-up wizard provides operators with an easier more intuitive methodology for gripper configurations.



terface. This allows them to move the robot arm position and set waypoints easily.

Easy connecting

- ASSISTA offers a wide variety of components-Grippers, Fingers, Vision and other peripherals-developed by our e-F@ctory Alliance

partners. These tools can easily be setup and configured for your application.

- ASSISTA can also be configured to move freely as part of an AGV/AMR or as a mobile robot.

(AGV:Automated Guided Vehicle, AMR:Autonomous Mobile Robot)

Recommended electric-powered gripper:

- Co-act EGP-C40-N-N-ASSISTA (SCHUNK)
- HRC-03-099455 (ZIMMER)
- KIT-ASSISTA-G (GIMATIC)
- ROB-SET ECBPM ASSISTA (SCHMALZ)



View with ASSISTA

ASSISTA and the camera capture the target using the "RT Visual-Box" auto-focus function.

"RT VisualBox" proprietary engineering tool

The vision camera focus adjustment and work registration can be configured simply by touching the screen. This means that you can use it even without special robot knowledge.

Vision sensor in-sight

The high-performance camera identifies the target and fixes position at high speed. Its compact size makes it ideal for attaching to the ASSISTA robot hand. This wire-saving type is equipped with PoE.

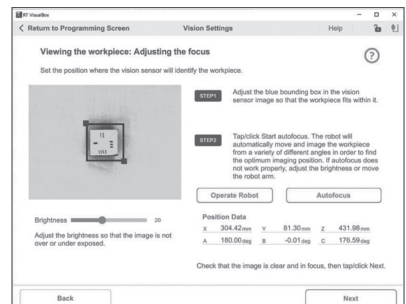

Screenshot RT VisualBox

Model designation



RV-7FRLM



RV-5AS



RV-8CRL

Vertical articulated robots (RV)

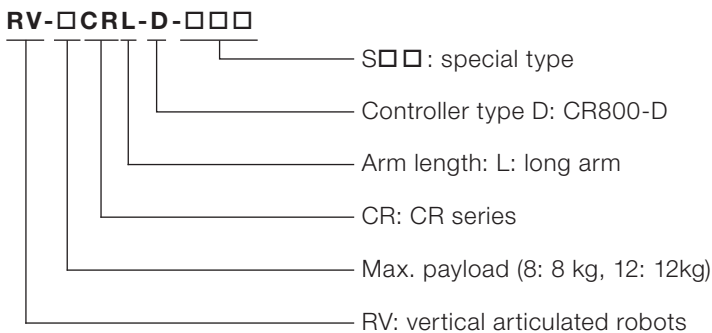
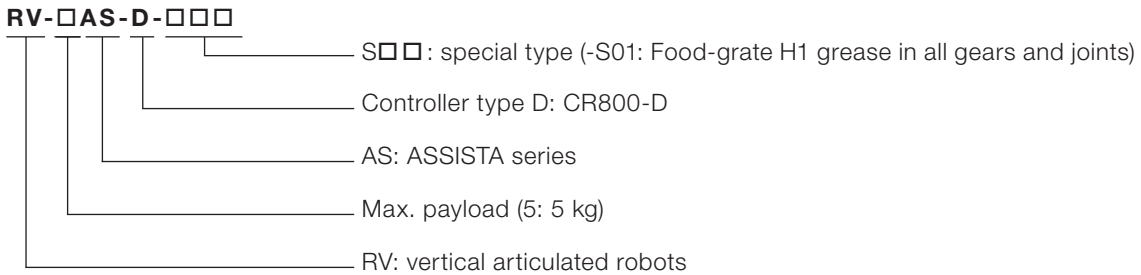
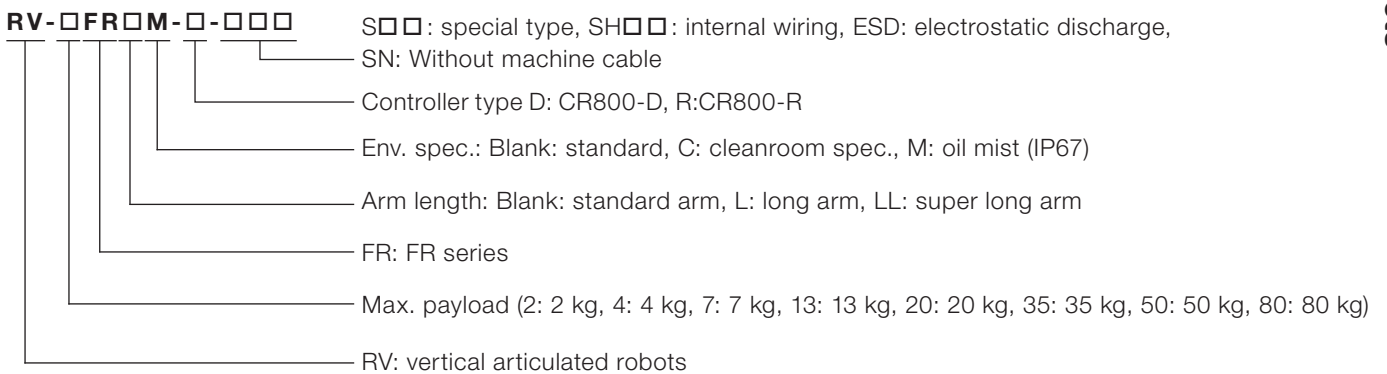

Model designation



RH-1FRHR5515



RH-6FRH5520N



RH-3CRH4018

Horizontal articulated robots (RH)

RH-□FRH□□N-□-□□□

- : special type, ESD: electrostatic discharge, SN: Without machine cable
- Controller type: D: CR800-D, R:CR800-R
- Env. spec.: Blank: standard, C: cleanroom spec., M: oil mist (IP67), N: IP54 and H1 grease
- Stroke length: 12: 120 mm, 15: 150 mm, 20: 200 mm, 34: 340 mm, 35: 350 mm, 45: 450 mm
- Arm length: 35: 350 mm, 45: 450 mm, 55: 550 mm, 70: 700 mm, 85: 850 mm, 100: 1000 mm
- FRH: FR series, FRHR: FR series ceiling type
- Max. payload (1: 1 kg, 3: 3 kg, 6: 6 kg, 12: 12 kg, 20: 20 kg)
- RH: horizontal articulated robots

RH-□CRH□□□□-D-□□□

- : special type, -S22: Bellow installed
- Controller type D: CR800-D
- Stroke length: 18: 180 mm, 20: 200 mm, 30: 300mm, 42: 420mm
- Arm length: 40: 400 mm, 60: 600 mm, 70: 700 mm, 80: 800mm, 85: 850mm, 100: 1000mm
- CRH: CRH series
- Max. payload (3: 3 kg, 6: 6 kg, 10: 10kg, 20: 20kg)
- RH: horizontal articulated robots



Advanced features maximizing FR series performance, further improving accuracy, efficiency, and quality

MELFA FR series has evolved further, promoting "next-generation manufacturing". It is now equipped with Mitsubishi Electric's unique algorithm that further boosts accuracy, efficiency, and quality in control. Moreover, it supports a wider range of applications, flexibly meeting the need of each customer's manufacturing process. MELFA FR series contributes to realization of next-generation manufacturing with higher productivity and quality.

MELFA FR series FR PLUS

MELFA FR series FR PLUS offers reduced positioning time and improved trajectory accuracy with the "MELFA High Drive function" and supports a wider range of applications with "expanded force sensor lineup". With these features, MELFA FR series FR PLUS flexibly meets the need of each customer's manufacturing processes and contributes to high productivity and quality. FR Plus robot models are fully compatible with FR series models as the FR Plus functions need to be activated.

MELFA High Drive function

Reduced positioning time

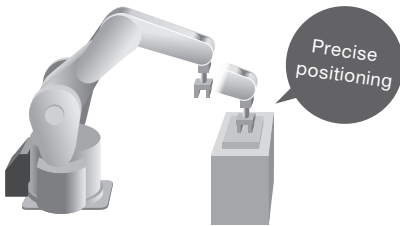

The vibrations that occur during positioning can be suppressed by using Mitsubishi Electric's unique vibration control algorithm. This enables a 30 % reduction of the positioning settling time, improving the cycle time. The improved cycle time leads to improved productivity.

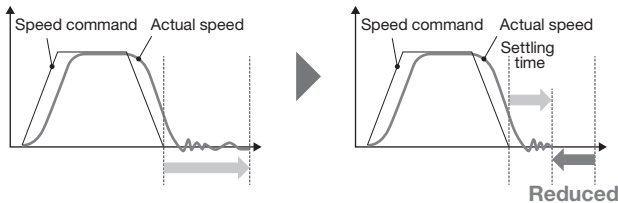

MELFA High Drive OFF

MELFA High Drive ON

High-accuracy trajectory control

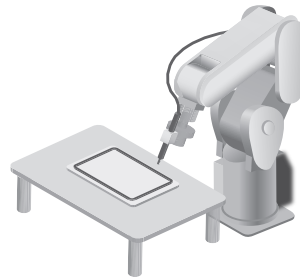

The trajectory accuracy is improved with trajectory compensation control. Setup adjustment has become easier since the trajectory fluctuation due to the speed and position less occurs. Furthermore, this function improves work quality, such as sealing process.



MELFA High Drive OFF

MELFA High Drive ON

Check the video that introduces the Mitsubishi Electric "vibration suppression" that realizes the MELFA High Drive function.



Shortened takt times

Improved control performance

Produced the fastest operating performance in its class using high-performance motors and unique driver control technology developed by Mitsubishi Electric.

- Enabled high torque output at high rotational speed, shortening acceleration/deceleration time
- Shortened positioning time for improved device throughput
- Continuous operability improved

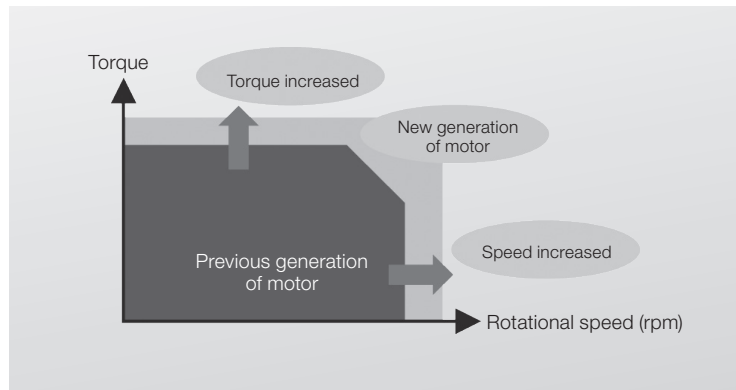

Tooling performance

Internal routing of hand wiring and signal cable

- Internal routing of cables and air hoses
- No interference with cables around devices
- Reduced risk of wiring disconnection
- Optional models of RV with internal wiring and hoses up to the hand are available (-SH□□)

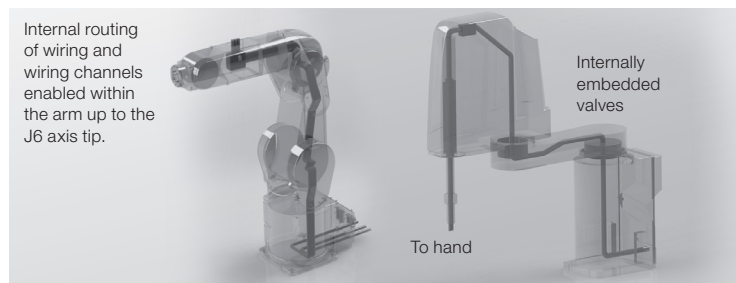

Flexibility with internal Ethernet cable tools

Internal installation of wiring and piping for connecting to vision sensors enabled.

- Hand: 8 input points/8 output points
- Ethernet cable for the vision sensor
- Additional cables to control vision systems or other sensors

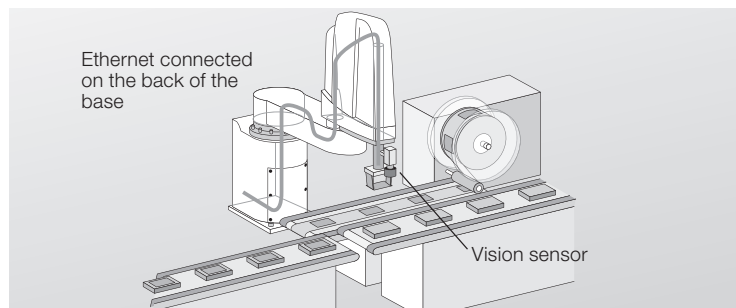

Full use of installation space

Expanded pivotal operating range

- Improved flexibility for robot layout design
- More effective use of access space around the entire perimeter
- Shortened movement distances, enabling takt times to be shortened

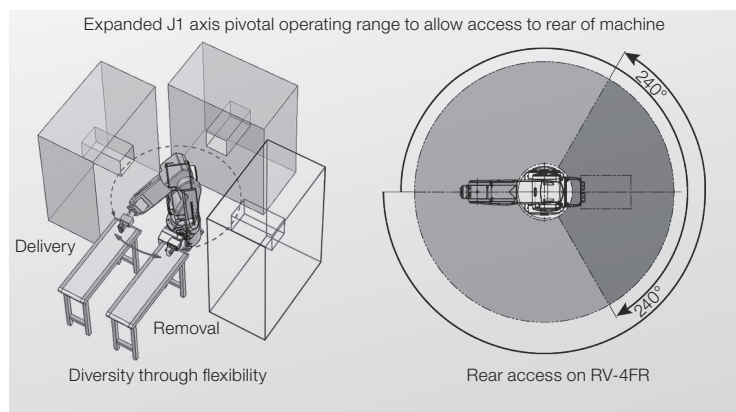

User friendliness

Simple automatic operation from the teaching box

- R86TB offers improved operability with an easy to operate and intuitive user interface
- Equipped with the major functions of RT Tool-Box3 such as program support functions, parameter and program screens
- 3D Monitor with display layout allows visualization of robot movements and providing a comprehensive view of the operation
- Early and easy troubleshooting with oscilloscope, various monitor and analysis screens



Enables automatic operation of servo motor on/off, startup and shutdown, reset, program selection, and other operations.

HMI backup/restore functions (Supported on GT14, GT15, GT16, GT21, GT23, GT25 and GT27)

Robot data on the GOT can be backed up to and restored from a CF-/SD-card or USB memory stick. Due to the direct Ethernet connection a PC is not required

- This helps prevent data from being lost due to the empty battery/battery or robot malfunction.
- Data can be saved after periodic maintenance tasks are performed or when unexpected errors occur. Dramatically improves serviceability



Maintenance (log function)

Information before and after errors occur (state changes, I/O, external system variables, etc.) and program run states can automatically be transferred to an FTP server as log data or saved on an SD card. Operation logs can also be downloaded, enabling efficient analysis of error causes.

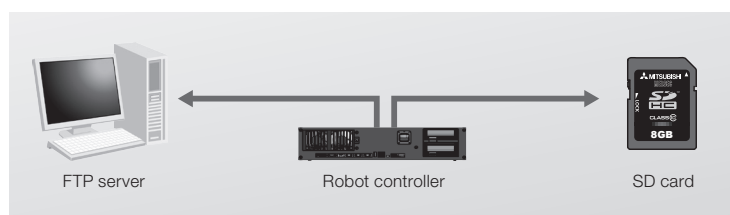

Easier robot information management

Memory is included in the robot body and used to store robot-specific information. This makes it easy to switch robot controllers.

Information can also be collected without visiting the workplace, simplifying the formulation of maintenance plans.

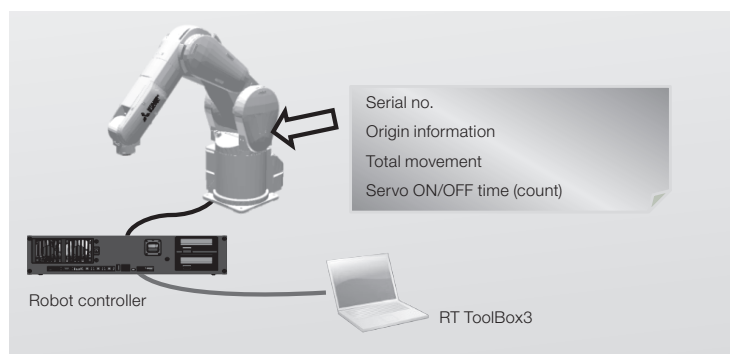

High accuracy

Active gain control

- Optimal motor control tuning settings in real-time based on robot operating position, posture and load conditions
- Improved palletization accuracy
- Improved trajectory accuracy
- Faster positioning without overshooting

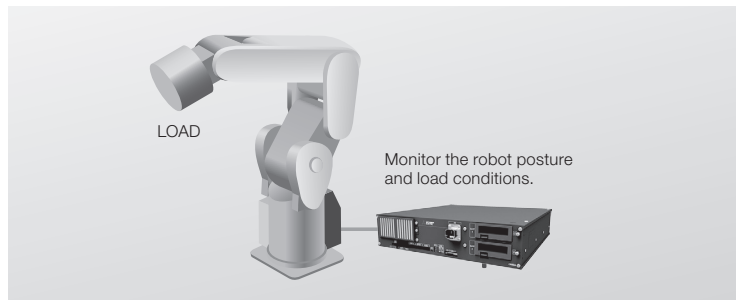

Simplified tool length setting

Tool settings for the tool coordinate system can be set by attaching the tool and using three to eight of the same teaching points.

- Eliminates errors introduced when the tool was made
- Higher precision
- Saving time, since measuring the tool is not necessary

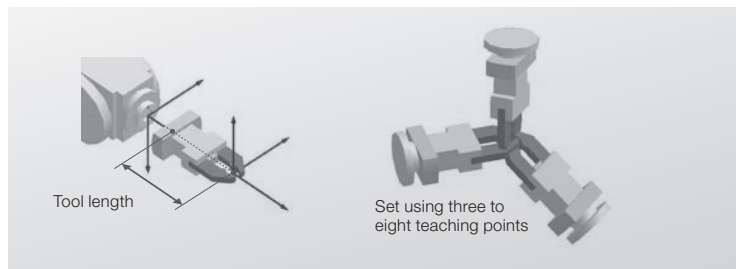

Adaptation to operation

Compliance control

This function reduces the rigidity of the robot arm and tracks external forces.

- Special hands and sensors are unnecessary
- Reduced tooling costs
- Shortened line stop times

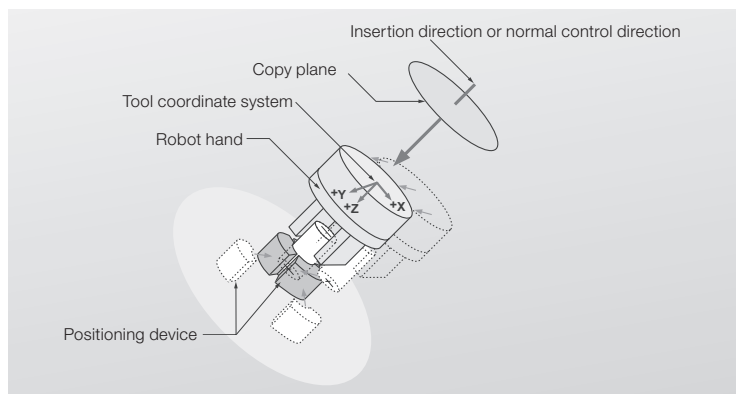

Collision detection function

This function detects if the arm collides with an obstacle while teaching or operation, and helps to reduce damaging the robot arm and tools. The detection level can be changed according to the protection targets.

The operation which should follow after the collision detection can be programmed to suit to the application, for example stop immediately and show error or retract and show then the error.

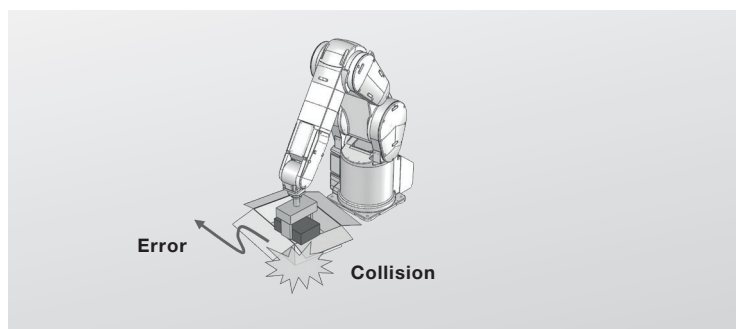

Connection to peripheral devices

Network vision sensor

The robot and camera can be easily simultaneously calibrated through a simple process using vision sensor setting tools.

- Simple connection between the robot and camera using Ethernet
- Simple control using vision control commands in the robot programs
- Shortened takt times
- Reduced system costs

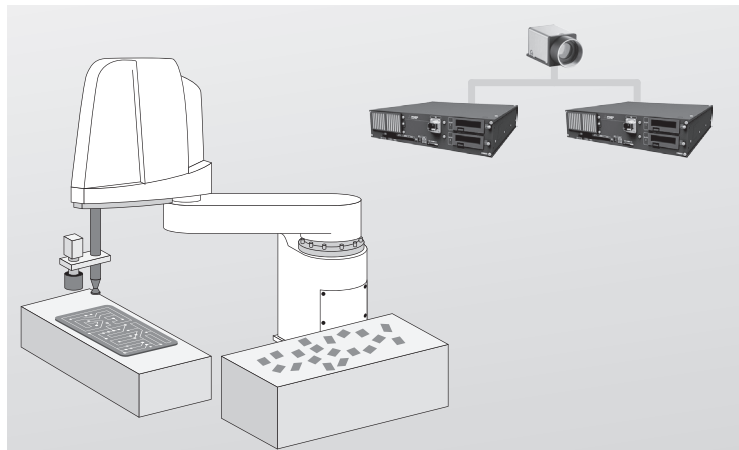

Tracking

Transport, alignment, and installation work, etc. can be performed while robots are tracked with the workpiece on the conveyor without stopping the conveyor.

- Higher throughput of components
- Easy programm creation (MELFA BASIC V/VI)
- No need for an additional positioning device
- Prediction of workpiece position for better tact times
- Circular tracking available

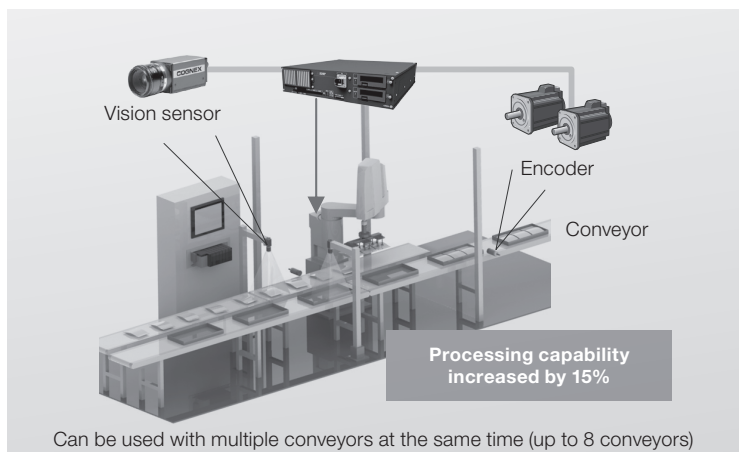

Additional axis function

The layout can be set up to include the robot traveling axis and turntable as well as user machines separate from the robot such as loaders and positioning devices.

- Up to 8 additional axes can be controlled by the controller
- No additional motion control hardware necessary
- Rotary and linear servomotors are supported
- Plug-and-play compatibility with the MELSERVO MR-J4-B servos
- Two axes can be controlled simultaneously with the robot
- No need of special programming knowledge, because robot software is used

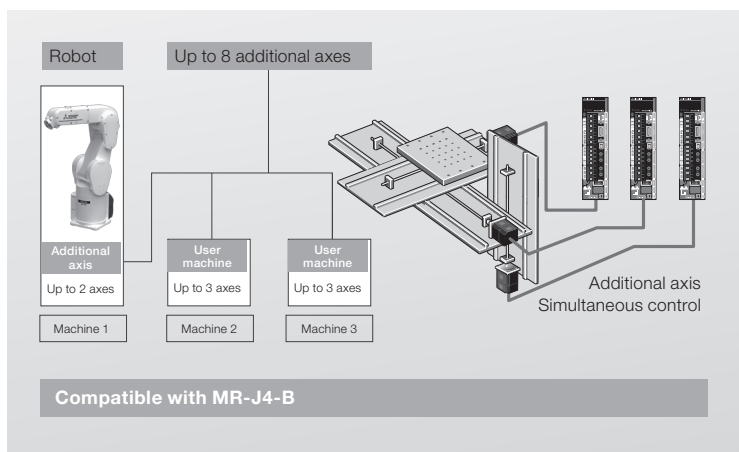

■ CC-Link IE Field Network Basic function

FR series robot controller supports the slave stations of “CC-Link IE Field Network Basic” as a built-in function.

- CC-Link IE Field Network Basic compatible products and Ethernet compatible products can be connected on the same Ethernet communications line
- MELSEC iQ-R/iQ-F/Q/L series PLC CPU and the MELFA FR series robot controller have built-in Ethernet as standard, so no dedicated option is required
- enabling a highly-flexible and cost-effective system

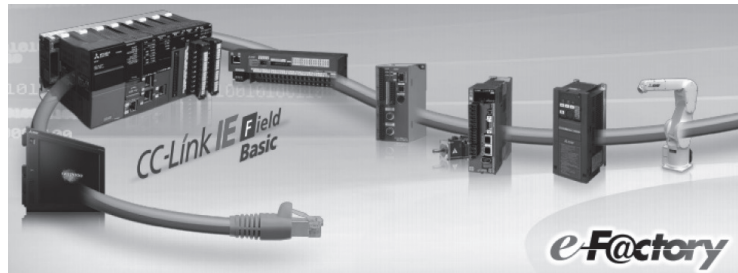

■ Collision avoidance (R type controllers only)

The robot is stopped, even before collisions can occur. This is possible due to the fast position control, that is implemented in the iQ Platform as a standard feature.

- Robots can operate together in a confined space without interfering with each other
- Reduces the number of recovery man-hours required after a collision
- Already represented in the simulation of the RT ToolBox3
- Can be used in Teach-Mode already

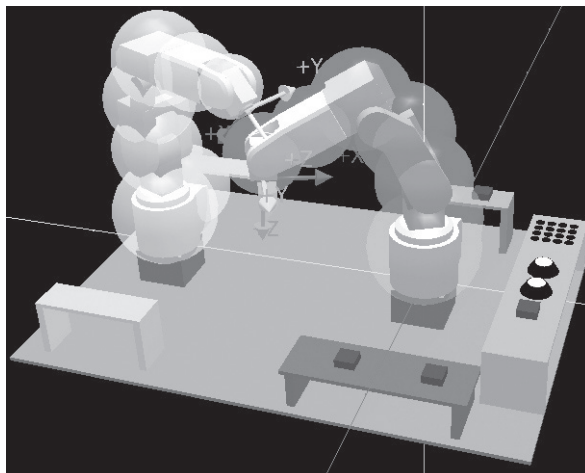

Possible collisions with other robots are avoided.

■ Coordinated control (R type controllers only)

Enables coordinated control between multiple robots through CPU connection between the robots.

- Easy to operate by predefined default function
- Enables transport of lengthy or heavy objects using small-sized robots
- Programming as already known by using standard commands



Enables installation work to be completed while gripper positions between robots are maintained.

Intelligent technology

Force sensor

- Monitors the force applied to the robot gripper to handle processes like a human operator
- Keeps the force constant so that the workpiece can be handled without causing damage
- Complex assembly tasks achieved through techniques such as phase matching
- Force log function for checking the quality check

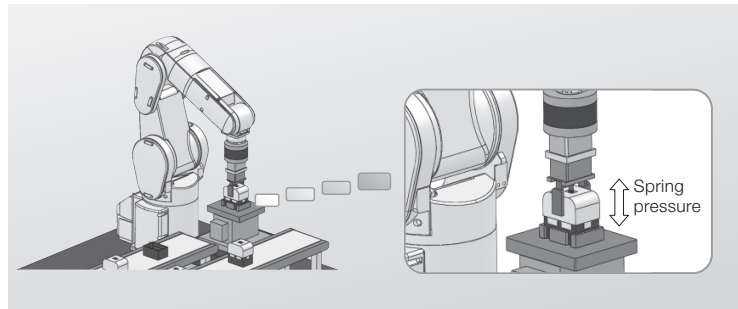

Arm temperature compensation

- Monitors temperature of motor encoders
- Improves positioning accuracy by compensating for thermal expansion in the robot arm

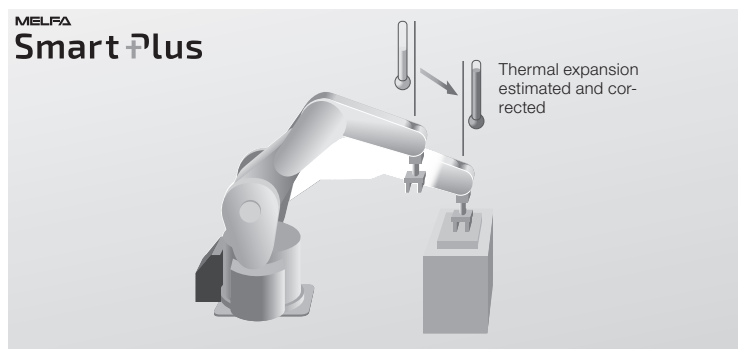

Calibration assistance

- Reduces the time for calibration during start up and improves position accuracy
- Automatically correcting the robot and camera coordinates
- Automatically correcting the robot and workpiece coordinates
- Adjust the robot location relative to other robots

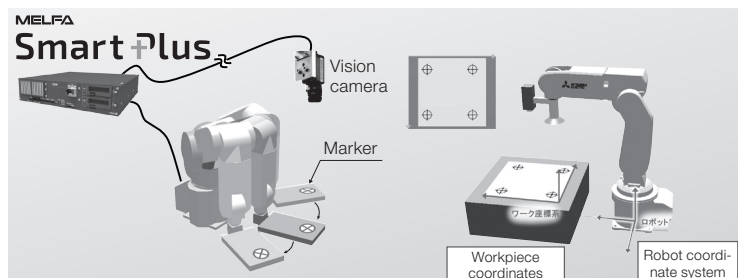

Coordinate control for additional axes

- Allows synchronized operation when a robot is installed on an additional axis (linear axis) to handle large workpieces which exceed robot's working range
- Allows synchronized operation when tracking of the robot with a workpieces on an additional axis (linear axis) is executed

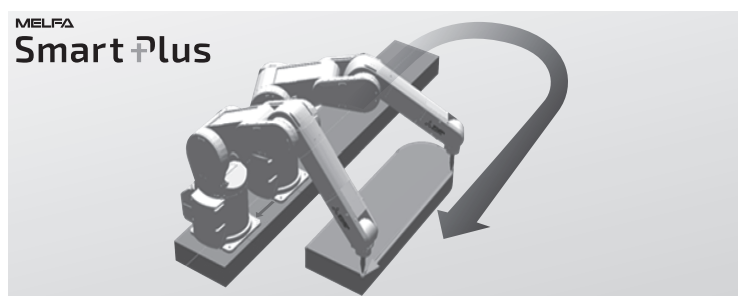

Predictive maintenance function

Consumption degree calculation function

- Identify the consumption degree of main components
 - A dynamic model and drive data are used to calculate the physical amount (force, speed, etc.) applied to each part.
 - By comparing this to the lifetime of the components, the consumption degree of each component is calculated. (Reduction gears, ball screws, belts, bearings, grease)
- Notify appropriate maintenance schedules
 - “Warning” and “general-purpose signal output” can be issued when maintenance is required.
- Identification of the appropriate maintenance schedule according to robot operating conditions
- This enables efficient, appropriate maintenance support

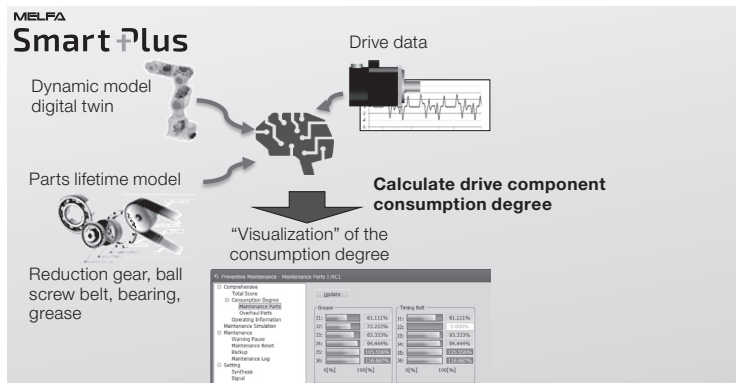

Abnormality detection function

- This function detects abnormalities or deterioration of robot reduction gear components early
- Current score of the reduction gear including reduction gears, encoder data abnormality, and encoder communication abnormality
- When the score exceeds the detection level, the reduction gear is assumed to be abnormal and an error (warning) occurs or that effect is notified by the dedicated output signal.
- The current status is displayed as the predictive maintenance message

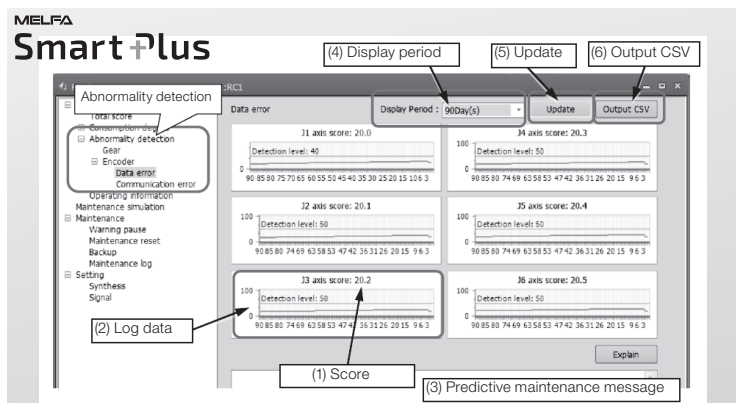

Maintenance simulation

- Estimate the maintenance schedule according to operation
 - Estimates the parts replacement time or the recommended maintenance time when a specific motion pattern (robot program) is repeated using simulations on RT ToolBox3
- Support for machine-friendly operation verification
 - By the offline simulation, the robot lifetime can be estimated
 - Operations can be verified by changing the operating program in consideration of tact time and lifetime
- Predict the robot lifetime and annual maintenance cost estimation already during the design stage
- Modify the robot operation to extend the life cycle

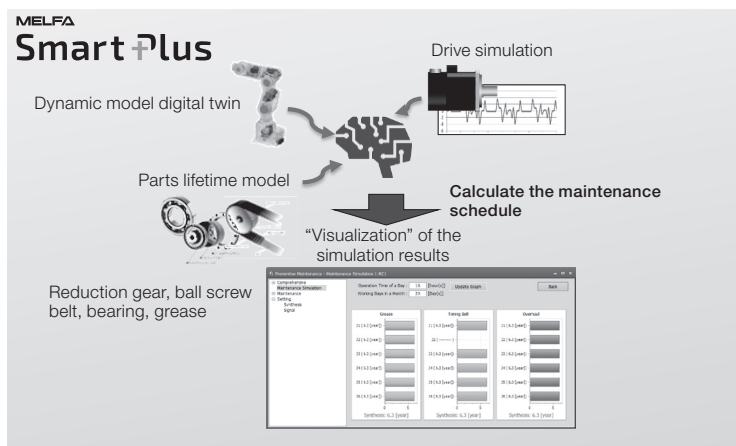

Predictive maintenance function

Integration in a maintenance system

- Support for forming a various maintenance system
 - Interaction with upper-level devices
 - Maintenance information is held as status variables
 - In addition to using maintenance data in the robot program, it is possible to obtain data from upper-level devices via communication middleware.
- Centralized management of robot maintenance data on an upper-level system

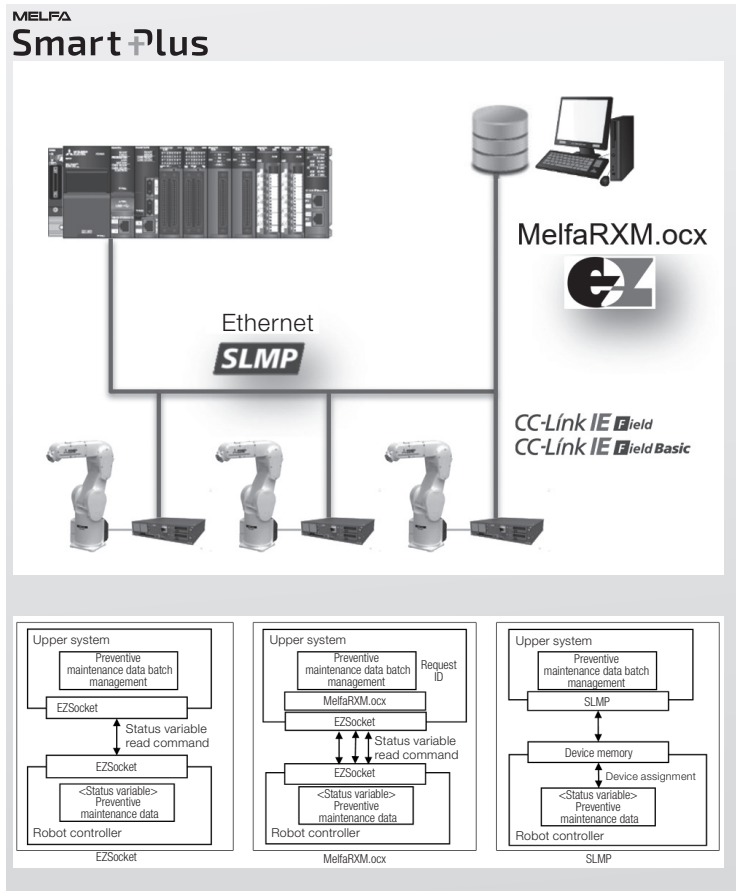

MELFA SafePlus features

“MELFA SafePlus” safety technology for the FR series robot controllers

- Supported Safety functions: STO (Safe Torque Off), SS1 (Safe Stop 1), SS2 (Safe Stop 2), SOS (Safe Operation Stop), SLS (Safely-Limited Speed), SLP (Safely-Limited Position)
- All functions follow the safety standards EN ISO 10218-1 (Industrial robots), EN ISO 13849-1 (Safety of machinery), EN 62061/IEC 61508 (Functional safety) and EN 61800-5-2 (Safety function drive).



Reduced speed control (safe limited speed, SLS)

Function to control the robot speed with safe limited speed to secure operator's safety when signaled via safety input signals. Up to four different zones with different limited speed can be activated. Operator can be interactive while the robot is running in automatic mode, but with safe low speed.



Limited range control (safe limited position, SLP)

Function to control the robot movement range and to ensure that the robot does not exceed the set limit activated by the safety input signal. This function monitors the robot arm. If the robot or the attached hand exceeds any set plane, the robot will stop immediately or before it.

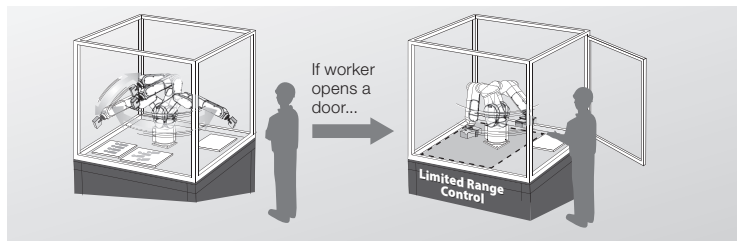

Independent areas can be defined for different safety situations.

Safety logic editing

Expands the dual safety channels to 8 inputs and 4 outputs. Logic for each safe I/O can be edited and in combination with the position monitoring function a safe system can be constructed without using a Safety PLC.

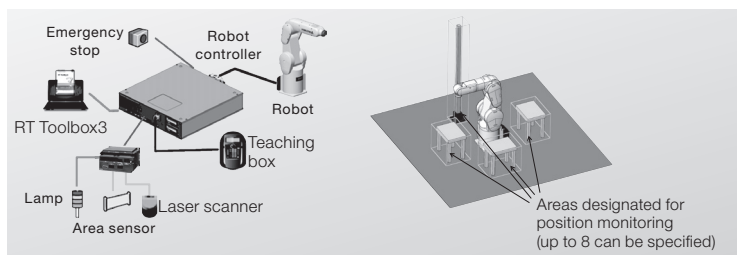

Special functions with GOT terminals and the iQ Platform

Shared memory expansion

Enhanced efficiency of monitoring and maintenance operations onsite using a single GOT (display device) as the Human Machine Interface (HMI).

- Enables the robot to be controlled from the GOT even without a teaching box
- Current robot position data, error information, and other items can be displayed easily on the GOT
- Connection with a single Ethernet cable and direct access to the control unit
- 8192 input an output points can be exchanged via Ethernet connection

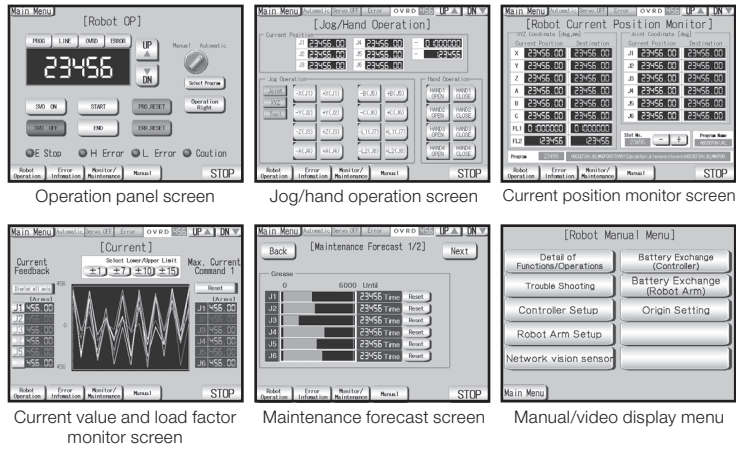

Direct execution function for programmable controllers

Robots can be controlled easily using programmable controller language.

- Control of system operation using an single programmable controller
- Direct changing of system specifications via programmable controller
- Direct handling of troubleshooting
- Simple movement to taught positions by PLC program
- No need to use any robot programs

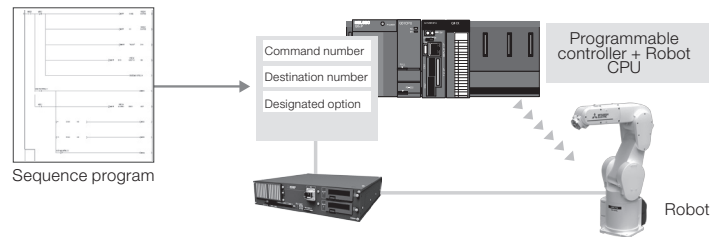

Details	
Operation	Joint-interpolated motion
	Linear-interpolated motion
Motion control	Designated override
	Designated acceleration/deceleration settings
	Designated speed
	Tool settings
	Designated auxiliary motion
	Opening/closing of hand

Industrial robots RV-2FR(B)/RV-2FRL(B)



RV-2FR(B)

The vertical articulated robots RV-2FR(B)/RV-2FRL(B)

The compact and light RV-2FR(B)/RV-2FRL(B) can be seamlessly integrated into different automation systems. Flexibility and the wide range of motion permits acting in applications with limited space, like mounting, assembling, palletising, sorting or bonding. Even the basic model is available with a fully equipped standard controller or as PLC robot with integration onto the iQ Platform.

Highlights:

- 2 different arm length with 504 mm and 649 mm
- Only 19/21 kg weight and extremely compact
- Highest flexibility
- Floor, wall and ceiling installation possible
- Position repeatability of ± 0.02 mm

* FR Plus compatible and MELFA High Drive function can be activated



Characteristics/Functions	Specifications			
	RV-2FR-D/ RV-2FR-R	RV-2FRB-D-S25/ RV-2FRB-R-S25	RV-2FRL-D-S25/ RV-2FRL-R-S25	RV-2FRLB-D-S25/ RV-2FRLB-R-S25
Degrees of freedom (no. of axes)	6			
Installation posture	Floor, ceiling or wall mounting possible			
Structure	Vertical articulated arm			
Drive system	AC servo axes J1, J4, J6: no brake	AC servo (brakes on all axes)	AC servo axes J1, J4, J6: no brake	AC servo (brakes on all axes)
Position detection method	Absolute encoder			
Payload capacity	rated	2		
	maximum	3		
Arm reachable radius (to the center point of the J5 axis)	mm	504	649	
Operating range	waist (J1)	480 (-240–240)		
	shoulder (J2)	240 (-120–120)		237 (-117–120)
	elbow (J3)	160 (0–160)		
	wrist twist (J4)	400 (-200–200)		
	wrist pitch (J5)	240 (-120–120)		
	wrist roll (J6)	720 (-360–360)		
Maximum speed	waist (J1)	300		225
	shoulder (J2)	150		105
	elbow (J3)	300		165
	wrist twist (J4)	450		412
	wrist pitch (J5)	450		
	wrist roll (J6)	720		
Maximum composite speed	mm/s	4955		4200
Cycle time (25x300x25 mm with 1 kg load)	sec	0.6		0.7
Position repeatability	mm	± 0.02		
Ambient temperature	°C	0–40		
Weight	kg	19		21
Tolerable moment	wrist twist (J4)	4.17		
	wrist pitch (J5)	4.17		
	wrist roll (J6)	2.45		
Tolerable inertia	wrist twist (J4)	0.18 (0.27)		
	wrist pitch (J5)	0.18 (0.27)		
	wrist roll (J6)	0.04 (0.1)		
Tool wiring	Hand input 4 points/hand output 4 points			
Tool pneumatic pipes	\varnothing 4x4 (from the base level to the gripper hand area)			
Supply pneumatic pressure	MPa	0.5 \pm 10 %		
Gripper flange	ISO 9409-1-31.5			
Protection rating	IP30			
Robot controller	CR860-D/CR800-R + R16RTCPU			
Order information	Art. no.	313052/ 314029	313053/ 314030	313054/ 314031
				313085/ 314032

Additional models without standard 5m machine cable are available.

Dimensions and movement ranges

Robot arms RV-2FR(L)(B)

RV-2FR(B)

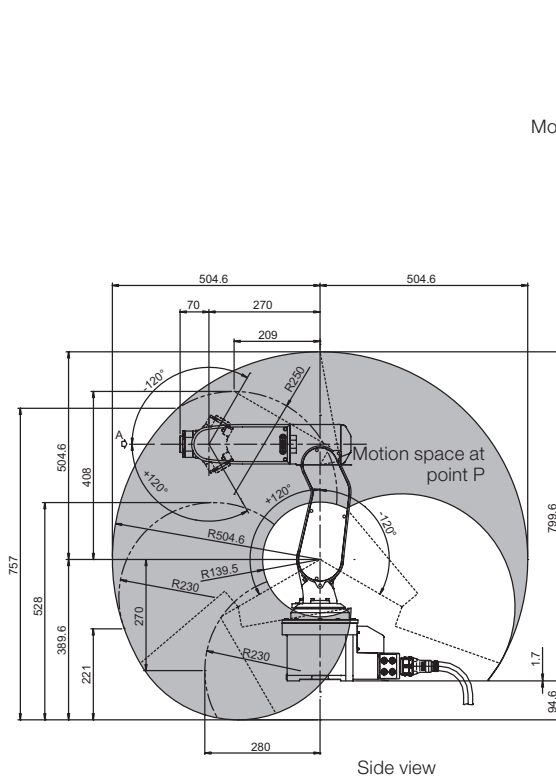

Side view

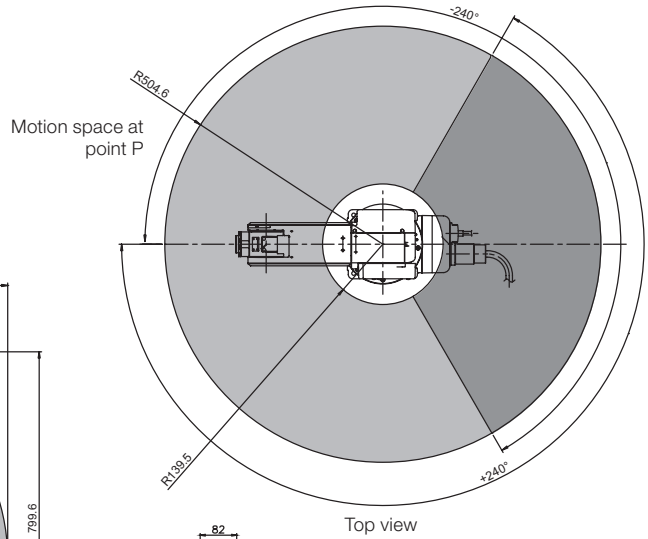

Motion space at point P

Top view

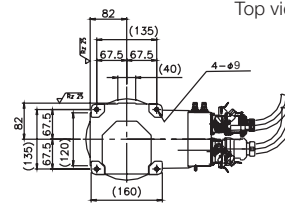

View x

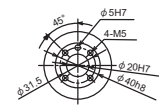

Dimensions: mm

RV-2FRL(B)

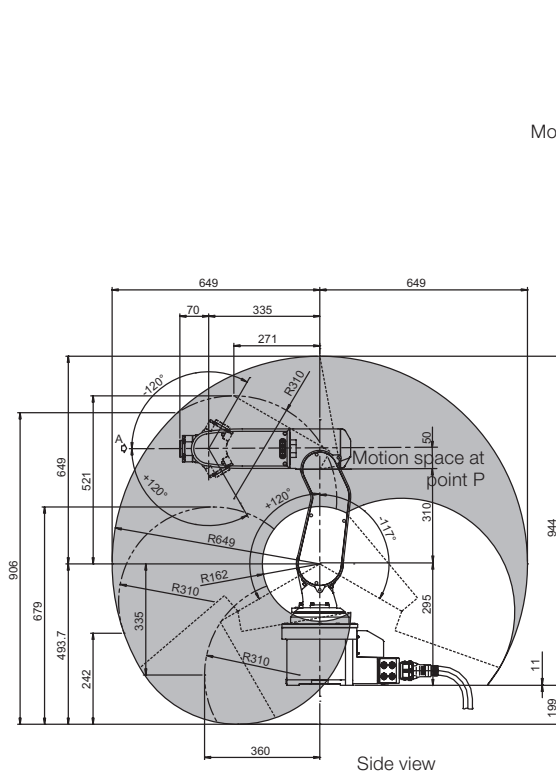

Side view

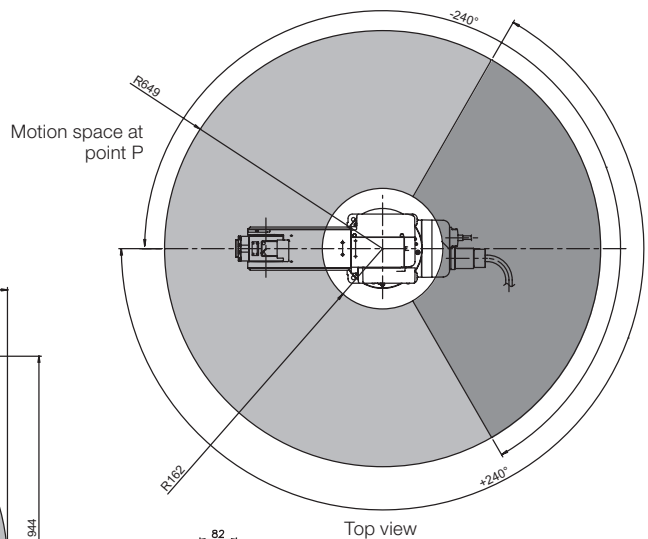

Motion space at point P

Top view

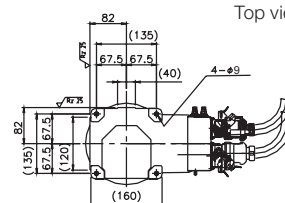

View x

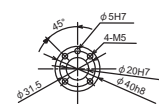

Dimensions: mm

Industrial robots RV-4FRLM



RV-4FRLM

The vertical articulated robots RV-4FRLM

The robots of the RV-4 FR series are designed for easy integration into existing work cells or innovative and compact applications. Features such as the direct control over local I/Os allows the robot to interact directly with sensors and actuators, speeding up and simplifying system building. A new innovative design allows a maximum of flexibility, so that the robot can expand his workspace to work faster and more flexible.

Highlights:

- Slim arm design
- IP67 protection
- Internal routed cables and air hoses
- Extended maintenance intervals
- 4 kg rated and maximal payload

* FR Plus compatible and MELFA High Drive function can be activated



Characteristics/Functions		Specifications	
		RV-4FRLM-D	RV-4FRLM-R
Degrees of freedom (no. of axes)		6	
Installation posture		Floor, ceiling or wall mounting possible (wall mounting with limitations in the J1 axis)	
Structure		Vertical articulated arm	
Drive system		AC servo (brakes on all axes)	
Position detection method		Absolute encoder	
Payload capacity	maximum	kg	4
Arm reachable radius (to the center point of the J5 axis)		mm	649
Operating range	waist (J1)	degree	480 (±240)
	shoulder (J2)		240 (-120-120)
	elbow (J3)		164 (0-164)
	wrist twist (J4)		400 (±200)
	wrist pitch (J5)		240 (-120-120)
	wrist roll (J6)		720 (±360)
Maximum speed	waist (J1)	degree/s	420
	shoulder (J2)		336
	elbow (J3)		250
	wrist twist (J4)		540
	wrist pitch (J5)		623
	wrist roll (J6)		720
Maximum composite speed		mm/s	9048
Cycle time (25x300x25 mm with 1 kg load)		sec	0.36
Position repeatability		mm	±0.02
Ambient temperature		°C	0-40
Weight		kg	41
Tolerable moment	wrist twist (J4)	Nm	6.66
	wrist pitch (J5)		6.66
	wrist roll (J6)		3.96
Tolerable inertia	wrist twist (J4)	kgm ²	0.20
	wrist pitch (J5)		0.20
	wrist roll (J6)		0.10
Tool wiring			Hand input 8 points/hand output 8 points
Tool pneumatic pipes			Ø 6x2 for robot connection (Ø4x8 from base portion to forearm)
Supply pneumatic pressure		MPa	0.54 (as overpressure if required)
Gripper flange			ISO 9409-1-31.5
Protection rating			IP67
Robot controller			CR800-D CR800-R + R16RTCPU
Order information	IP67 model	Art. no.	313089 314056
	IP40 model		313088 314055

Please contact your Mitsubishi Electric representative for ESD, ATEX and cleanroom models. Additional models without standard 5m machine cable are available.

Robot arms RV-4FRLM

RV-4FRL

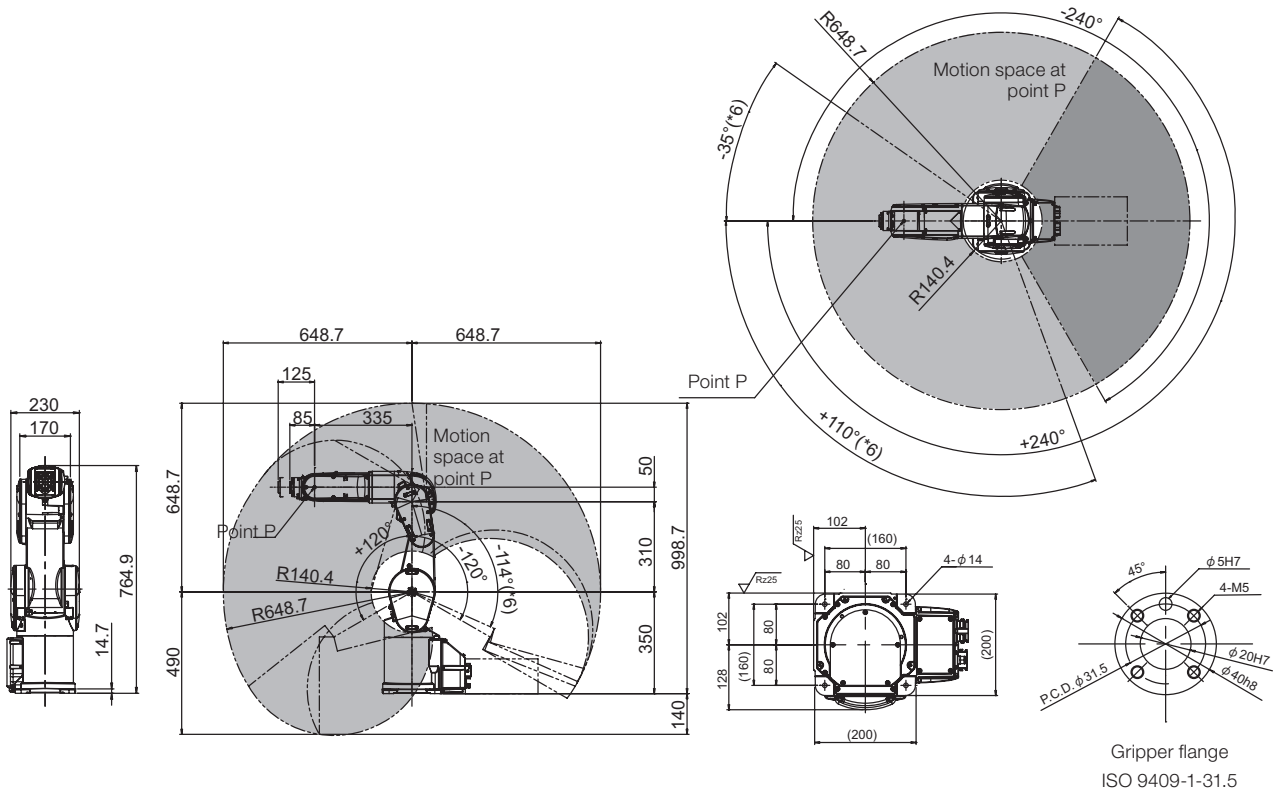

Gripper flange
ISO 9409-1-31.5

Dimensions: mm

Industrial robots RV-7FRM/7FRLM/7FRLM



RV-7FRLM

The vertical articulated robots RV-7FRM/7FRLM/7FRLM

The RV-7FRM with a nominal and maximum payload of 7 kg sets new benchmark standards for speed, flexibility, ease of integration and simplicity of programming. For an optimum work radius the robot is available in three versions with ranges from 713 mm to 1503 mm. Ethernet, USB, tracking, camera connection and additional axis connections are standard in all MELFA Robot Series.

Highlights:



- Cycle time of only 0.32 s (RV-7FRM) for a 12-inch cycle
- Drastically increased working range for J1 and J4 axis for a maximum working area
- Internal wiring
- IP67 protection
- Workspace radius of up to 1503 mm (RV-7FRLM)

* FR Plus compatible and MELFA High Drive function can be activated

Characteristics/Functions		Specifications			
		RV-7FRM-D/ RV-7FRM-R	RV-7FRLM-D/ RV-7FRLM-R	RV-7FRLM-D RV-7FRLM-R	
Degrees of freedom (no. of axes)		6			
Installation posture		Floor, ceiling or wall mounting possible (wall mounting with limitations in the J1 axis)			
Structure		Vertical articulated arm			
Drive system		AC servo (brakes on all axes)			
Position detection method		Absolute encoder			
Payload capacity	maximum	kg		7	
Arm reachable radius (to the center point of the J5 axis)		mm	713	908	1503
Operating range	waist (J1)	degree	480 (±240)		380 (±190)
	shoulder (J2)		240 (-115-125)		240 (-90-150)
	elbow (J3)		156 (0-156)		162 (0-162)
	wrist twist (J4)		400 (±200)		167.5 (-10-157.5)
	wrist pitch (J5)		240 (-120-120)		
	wrist roll (J6)		720 (±360)		
Maximum speed	waist (J1)	degree/s	360		234
	shoulder (J2)		401		164
	elbow (J3)		450		219
	wrist twist (J4)		337		375
	wrist pitch (J5)		450		
	wrist roll (J6)		720		
Maximum composite speed		mm/s	11064	10977	15300
Cycle time (25x300x25 mm with 1 kg load)		sec	0.32	0.35	0.63
Position repeatability		mm	±0.02		±0.06
Ambient temperature		°C	0-40		
Weight		kg	65	67	130
Tolerable moment	wrist twist (J4)	Nm	16.2		
	wrist pitch (J5)		16.2		
	wrist roll (J6)		6.86		
Tolerable inertia	wrist twist (J4)	kgm ²	0.45		
	wrist pitch (J5)		0.45		
	wrist roll (J6)		0.10		
Tool wiring		Hand input 8 points/hand output 8 points			
Tool pneumatic pipes		Ø 6x2 for robot connection (Ø4x8 from base portion to forearm)			
Supply pneumatic pressure		MPa	0.54 (as overpressure if required)		
Gripper flange		ISO 9409-1-31.5			
Protection rating		IP67			
Robot controller		CR800-D/CR800-R + R16RTCPU			
Order information	IP67 model	Art. no.	313091/ 314058	313093/ 314060	313095/ 314062
	IP40 model		313090/ 314057	313092/ 314059	313094/ 314061

Please contact your Mitsubishi Electric representative for ESD, ATEX and cleanroom models. Additional models without standard 5m machine cable are available.

Dimensions and movement ranges

Robot arms RV-7FRM/7FRLM/7FRLLM

RV-7FRM

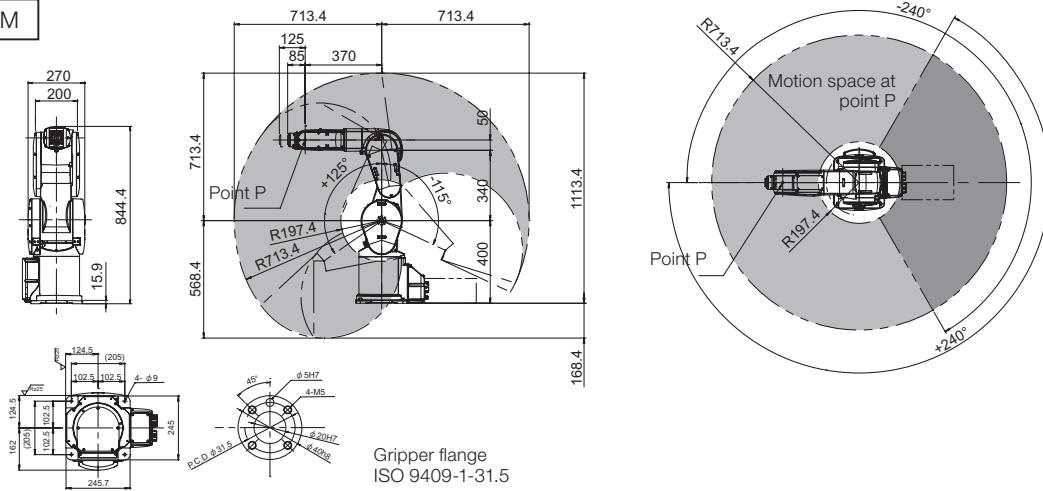

RV-7FRLM

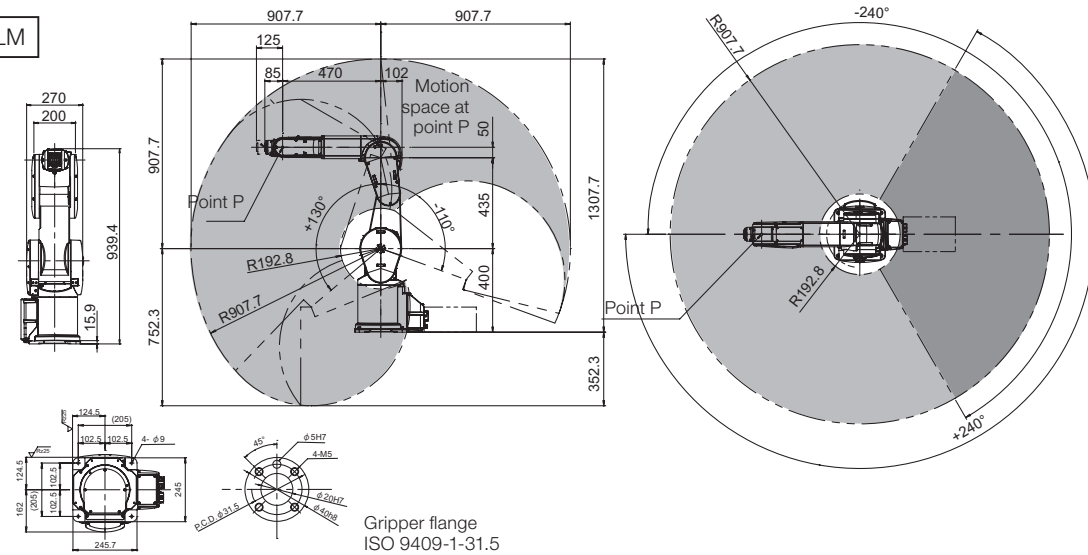

RV-7FRLLM

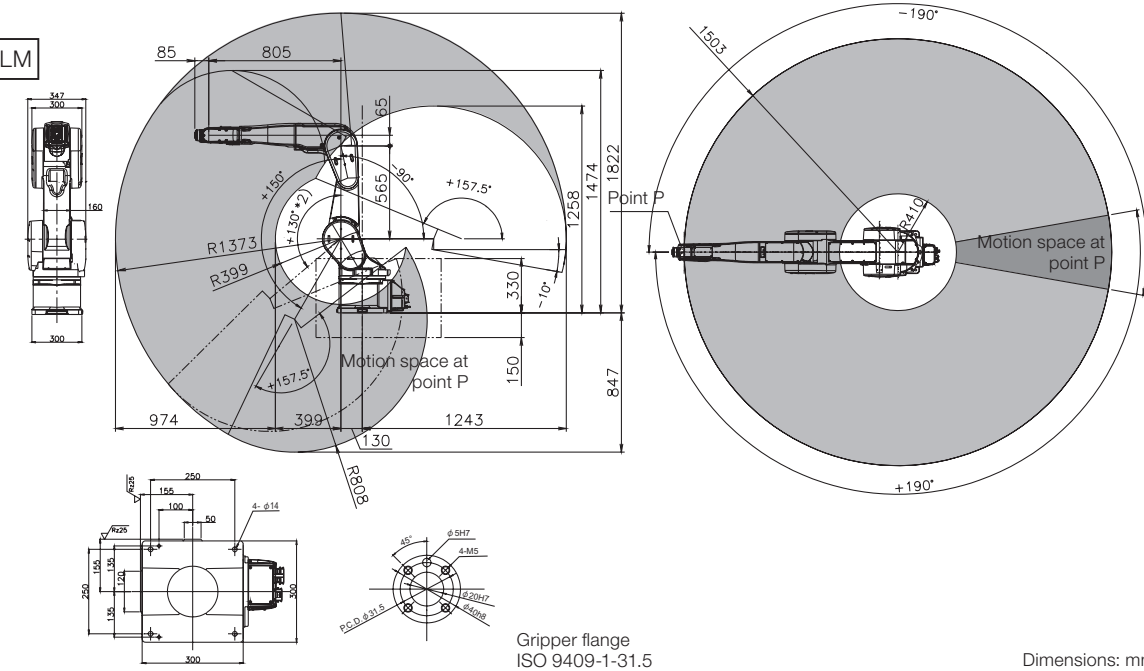

Dimensions: mm

Industrial robots RV-13FRM/RV-13FRLM/RV-20FRM



RV-20FRM

The vertical articulated robots RV-13FRM/RV-13FRLM/RV-20FRM

The high-performance robots RV-13 and RV-20 are especially suited for handling heavy loads. Due to the compact body and slim arm design, the robots can operate in a large work area. The anti-collision function of the iQ Platform models prevents collisions between robots which are working closely together.

Highlights:

- internal routing of cables and air hoses through the robot arm
- new gears for quiet, precise positioning and movement
- maximum payload of 20 kg (RV-20FRM)
- Protection rating IP67 standard

* FR Plus compatible and MELFA High Drive function can be activated



Characteristics/Functions	Specifications				
	RV-13FRM-D RV-13FRM-R	RV-13FRLM-D RV-13FRLM-R	RV-20FRM-D RV-20FRM-R		
Degrees of freedom (no. of axes)	6				
Installation posture	Floor, ceiling or wall mounting possible (wall mounting with limitations in the J1 axis)				
Structure	Vertical articulated arm				
Drive system	AC servo (all axes with brakes)				
Position detection method	Absolute encoder				
Payload capacity	rated	12	15		
	maximum	13	20		
Arm reachable radius (to the center point of the J5 axis)	1094	1388	1094		
Operating range	waist (J1)	380(±190)			
	shoulder (J2)	240 (-90–150)			
	elbow (J3)	167.5 (-10–157.5)			
	wrist twist (J4)	400 (±200)			
	wrist pitch (J5)	240 (-120–120)			
	wrist roll (J6)	720 (±360)			
Maximum speed	waist (J1)	290	110		
	shoulder (J2)	234	110		
	elbow (J3)	312	110		
	wrist twist (J4)	375	124		
	wrist pitch (J5)	375	125		
	wrist roll (J6)	720	360		
Maximum composite speed	10450	9700	4200		
Cycle time (25x300x25 mm with 1 kg load)	0.53	0.68	0.70		
Position repeatability	±0.05				
Ambient temperature	0–40				
Weight	120	130	120		
Tolerable moment	wrist twist (J4)	19.3	49.0		
	wrist pitch (J5)	19.3	49.0		
	wrist roll (J6)	11			
Tolerable inertia	wrist twist (J4)	0.47	1.40		
	wrist pitch (J5)	0.47	1.40		
	wrist roll (J6)	0.14			
Tool wiring	Hand input 8 points/hand output 8 points				
Tool pneumatic pipes	Primary: Ø 6x2, secondary: Ø 6x8				
Supply pneumatic pressure	0.54 (as overpressure if required)				
Gripper flange	ISO 9409-1-40				
Protection rating	IP67				
Robot controller	CR800-D/CR800-R + R16RTCPU				
Order information	IP67 model	Art. no.	313097/	313099/	312663/
			314064	314066	314068
	IP40 model	Art. no.	313096/	313098/	313100/
			314063	314065	314067

Please contact your Mitsubishi Electric representative for ESD, ATEX and cleanroom models. Additional models without standard 5m machine cable are available.

Dimensions and movement ranges

Robot arms RV-13FRM/RV-13FRLM/RV-20FRM

RV-13FRM/20FRM/13FRLM

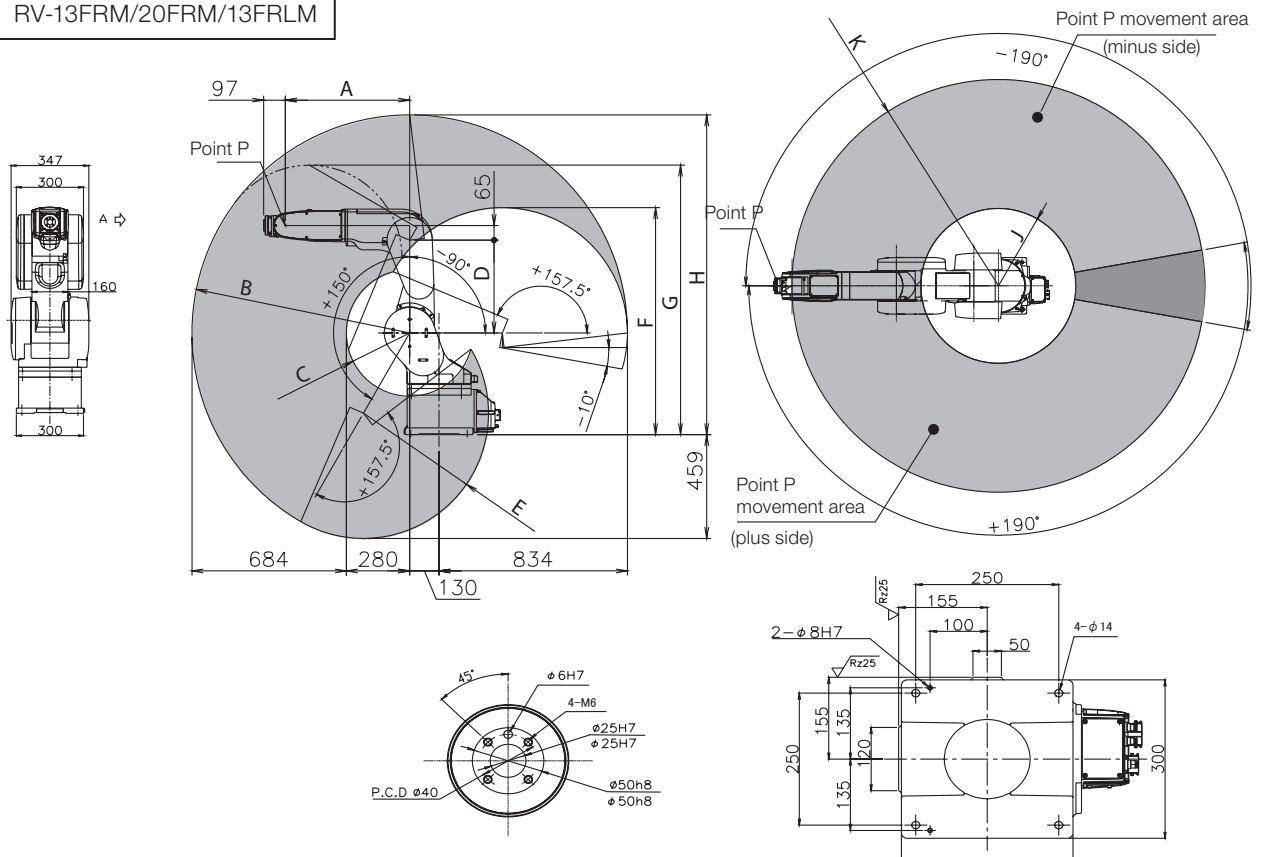

Dimensions: mm

Variable dimensions

Robot series	A	B	C	D	E	F	G	H	J	K
RV-13FRM/20FRM	550	R964	R280	410	R554	1004	1191	1414	R410	R1094
RV-13FRLM	690	R1258	R328	565	R693	1143	1416	1708	R458	R1388

Industrial robots RV-35FR/50FR/80FR



RV-35FR/50FR/80FR

High capacity robots RV-35FR/50FR/80FR

These robots with payload from 35 kg up to 80 kg are addressing applications that require higher payloads and longer reaches, including CNC machine tending, large material handling, palletizing and end of line packaging.

Highlights:

- Long reach arm up to 2100 mm for tasks can be spread farther apart and can accommodate larger parts and processes
- Multiple environmental protection rating and IP67 for various application requirements
- Seamless integration in the Mitsubishi Electric automation world

Characteristics/Functions		Specifications			
		RV-35FRM-D/ RV-35FRM-R ¹	RV-50FRM-D/ RV-50FRM-R ¹	RV-80FRM-D/ RV-80FRM-R ¹	
Degrees of freedom (no. of axes)		6			
Installation posture		Floor			
Structure		Vertical articulated arm			
Drive system		AC servo (all axes with brakes)			
Position detection method		Absolute encoder			
Payload capacity		kg	35	50	80
Arm reachable radius (to the center point of the J5 axis)		mm	2100		
Operating range	waist (J1)	degree	360 (±180)		
	shoulder (J2)		245 (-105–140)		
	elbow (J3)		290(-135–155)		
	wrist twist (J4)		720 (±360)		
	wrist pitch (J5)		290 (±145)		
	wrist roll (J6)		900 (±450)		
Maximum speed	waist (J1)	degree/s	185	180	180
	shoulder (J2)		180	180	180
	elbow (J3)		185	185	160
	wrist twist (J4)		260	260	185
	wrist pitch (J5)		260	260	165
	wrist roll (J6)		360	360	280
Maximum composite speed		mm/s	13400	13400	12700
Position repeatability		mm	±0.06		
Ambient temperature		°C	0–45		
Weight		kg	560		
Tolerable moment	wrist twist (J4)	Nm	210	210	336
	wrist pitch (J5)		210	210	336
	wrist roll (J6)		130	130	194
Tolerable inertia	wrist twist (J4)	kgm ²	19.6	28	34
	wrist pitch (J5)		19.6	28	34
	wrist roll (J6)		7.7	11	13.7
Tool wiring		12 input points/8 output points/LAN x 1 (Category 5e)			
Tool pneumatic pipes		Ø 10x2			
Supply pneumatic pressure		MPa	Max. 0.49		
Protection rating		IP65/IP67			
Robot controller		CR860-D/CR860-R + R16RTCPU			
Order information		Art. no.	701530/ 703712	701531/ 703713	701602/ 703714

Please contact your Mitsubishi Electric representative for options.

Robot arms RV-35FR/50FR/80FR

RV-35FR/50FR/80FR

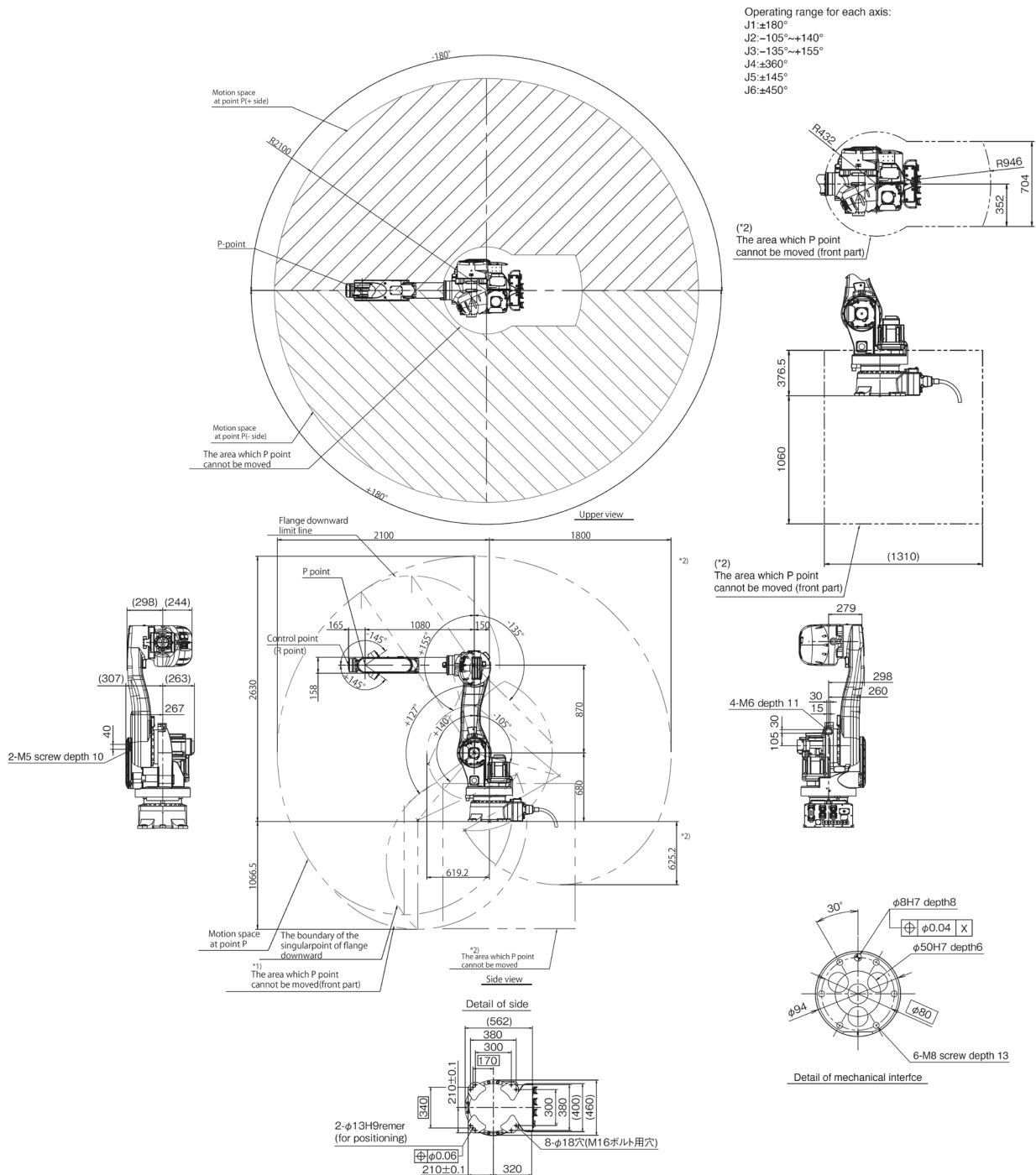

1. The posture of side view

The following figure shown a robot at the position of: J1=0°, J2=0°, J3=90°, J4=0°, J5=0°, J6=0°

2. *1) Rear face operating limit: When the J axis angle is J1 ≤ -137° or +137° ≤ J1,

the J2 axis operation is limited to J2 ≤ +127°

3. *2) The area which P point cannot be moved: P point cannot move to this area. This limitation is valid at factory shipping, but it can be released by parameter MELTEXS.

MELFA ASSISTA collaborative robots RV-5AS-D



RV-5AS-D

The collaborative robots RV-5AS-D

MELFA ASSISTA does not require specialized knowledge or expertise.

Advanced safety technology enables humans to collaborate with robots in manufacturing processes and to share workspace.

Highlights:

- Simpler and easier
- Easy control
- Easy visual programming
- Easy connecting

Characteristics/Functions		Specifications	
		RV-5AS-D	RV-5AS-D-S01
Degrees of freedom (no. of axes)		6	
Installation posture		Floor and ceiling mounting possible	
Structure		Vertical articulated arm	
Drive system		AC servo (brakes on all axes)	
Position detection method		Absolute encoder	
Payload capacity	maximum	kg	5
Arm reachable radius (to the center point of the J5 axis)		mm	910
Operating range	waist (J1)	degree	±240
	shoulder (J2)		±148
	elbow (J3)		±150
	wrist twist (J4)		±200
	wrist pitch (J5)		±120
	wrist roll (J6)		±200
Maximum speed	waist (J1)	degree/s	124 (59.6)
	shoulder (J2)		124 (34.0)
	elbow (J3)		124 (34.0)
	wrist twist (J4)		297 (142)
	wrist pitch (J5)		356 (215)
	wrist roll (J6)		360
Maximum composite speed		mm/s	1000
Position repeatability		mm	±0.03 ±0.05
Ambient temperature		°C	0–40
Weight		kg	32
Tolerable moment	wrist twist (J4)	Nm	12.8
	wrist pitch (J5)		12.8
	wrist roll (J6)		4.9
Tolerable inertia	wrist twist (J4)	kgm ²	0.34
	wrist pitch (J5)		0.34
	wrist roll (J6)		0.10
Tool wiring		Mechanical interface: 2 inputs/4 outputs	
		Forearm: 6 inputs/0 outputs	
		Base: 0 inputs/4 outputs	
Tool pneumatic pipes		Primary: Ø6×2, secondary: Ø4×4	
Supply pneumatic pressure		MPa	0.54
Gripper flange		ISO 9409-1-40	
Protection rating/environment		IP54/ISO class 5	Food-grade H1 grease in all gears and joints, hexagon stainless steel screws
Robot controller		CR800-D	
Order information		Art. no.	502852 502313

Robot arms RV-5AS-D

RV-5AS-D

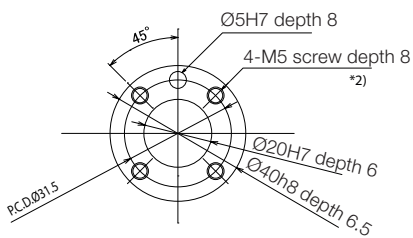
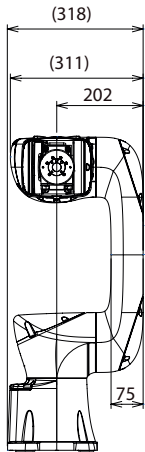

View A: Detail of mechanical interface

*2) The depth in which the screw is tightened is 7.5 to 8 mm.

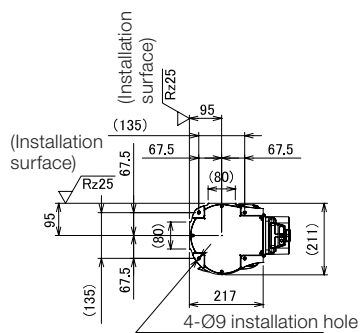

View B: Detailed installation dimensions

The following figure shows a robot at the position of:

$J1=0^\circ, J2=0^\circ, J3=90^\circ, J4=0^\circ, J5=0^\circ,$ and $J6=0^\circ$

Upper view

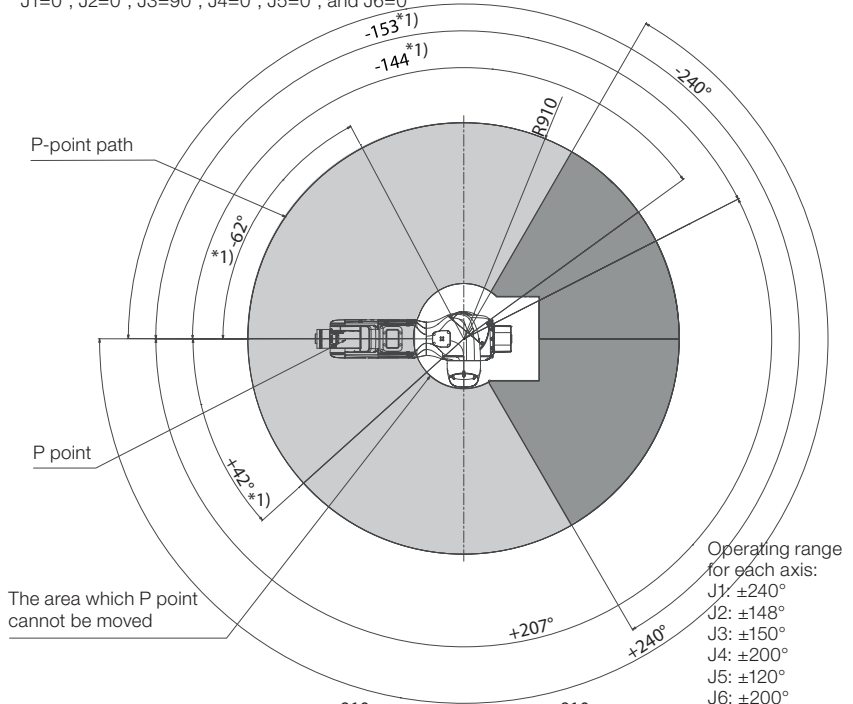

The area which P point cannot be moved

Operating range for each axis:
 $J1: \pm 240^\circ$
 $J2: \pm 148^\circ$
 $J3: \pm 150^\circ$
 $J4: \pm 200^\circ$
 $J5: \pm 120^\circ$
 $J6: \pm 200^\circ$

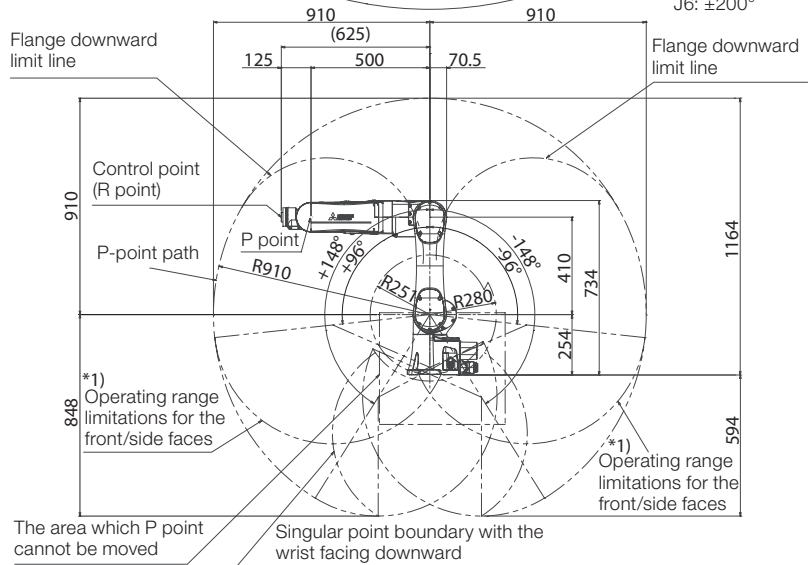

*1) Limits of the front operating range:

If the angle of $J1$ is $-62^\circ \leq J1 \leq +207^\circ$ or $J1 \leq -153^\circ$, then $J2$ is limited to $-96^\circ \leq J2$.

If the angle of $J1$ is $+42^\circ \leq J1$ or $J1 \leq -144^\circ$, then $J2$ is limited to $J2 \leq +96^\circ$.

If the angle of $J2$ is $J2 \leq -95^\circ$, then $J3$ is limited to $J3 \leq +146^\circ$.

If the angle of $J2$ is $J2 \leq +30^\circ$, then $J3$ is limited to $-146^\circ \leq J3$.

Dimensions: mm

Industrial robot RV-8CRL/12CRL



RV-8CRL

The vertical articulated robot RV-8CRL and RV-12CRL

In addition to a slim, compact exterior and small robot base, its structure features minimal protrusions to the front, back, and sides, resulting in reduced interference with surroundings when the robot operates. This makes it suited to integration with automation cells and manufacturing equipment.

Highlights:

- Compact and functional design
- High permissible moment and inertia for heavy objects and large hands handling
- Beltless coaxial drive mechanism in most axes
- User wiring/piping built into arm
- No backup battery
- IP65 protection
- I/O option card 2D-TZ378 with 32 inputs/32 outputs is included

Characteristics/Functions		Specifications		
		RV-8CRL-D-S15	RV-12CRL-D-S15	
Degrees of freedom (no. of axes)		6		
Installation posture		Floor, ceiling or wall mounting possible (wall mounting with limitations in the J1 axis)	Floor, ceiling	
Structure		Vertical articulated arm		
Drive system		AC servo (brakes on all axes)		
Position detection method		Absolute encoder		
Payload capacity	maximum	kg	8	12
Arm reachable radius (to the center point of the J5 axis)		mm	931	1504
Operating range	waist (J1)	degree	±170	±170
	shoulder (J2)	degree	±110	-90-150
	elbow (J3)	degree	0-165	0-170
	wrist twist (J4)	degree	±200	±190
	wrist pitch (J5)	degree	±120	±120
	wrist roll (J6)	degree	±360	±360
Maximum speed	waist (J1)	degree/s	288	270
	shoulder (J2)	degree/s	321	253
	elbow (J3)	degree/s	360	290
	wrist twist (J4)	degree/s	337	487
	wrist pitch (J5)	degree/s	450	480
	wrist roll (J6)	degree/s	720	780
Maximum composite speed		mm/s	10500	10500
Cycle time (25x300x25 mm with 1 kg load)		sec	0.44	0.38
Position repeatability		mm	±0.02	±0.04
Ambient temperature		°C	0-40	0-40
Weight		kg	41	110
Tolerable moment	wrist twist (J4)	Nm	16.2	26.5
	wrist pitch (J5)	Nm	16.2	26.5
	wrist roll (J6)	Nm	6.86	11
Tolerable inertia	wrist twist (J4)	kgm ²	0.45	0.9
	wrist pitch (J5)	kgm ²	0.45	0.9
	wrist roll (J6)	kgm ²	0.10	0.3
Tool wiring			15-pins, D-sub	15-pins x2
Tool pneumatic pipes			∅ 6x2	∅ 6x2, ∅ 8x1
Supply pneumatic pressure		MPa	0.54	
Gripper flange			ISO 9409-1-40	
Protection rating			IP65	
Robot controller			CR800-D	
Order information		Art. no.	492799	713769

Dimensions and movement ranges

Robot arms RV-8CRL/RV-12CRL

RV-8CRL

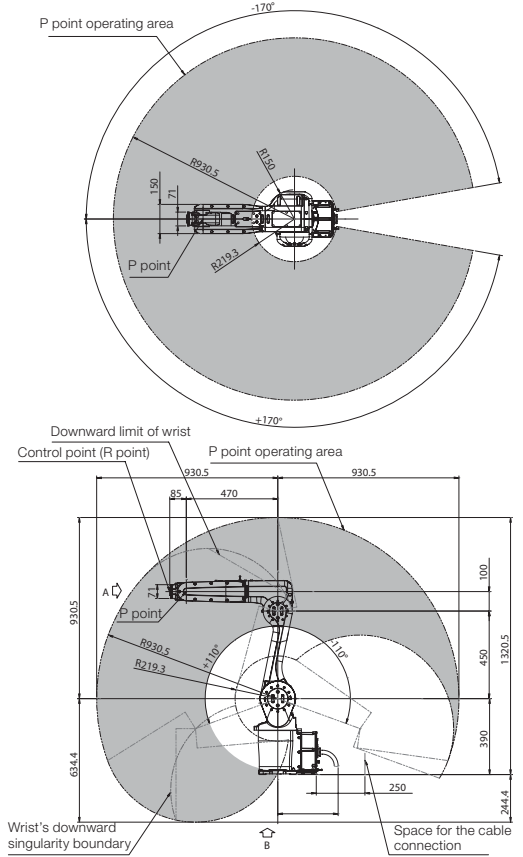
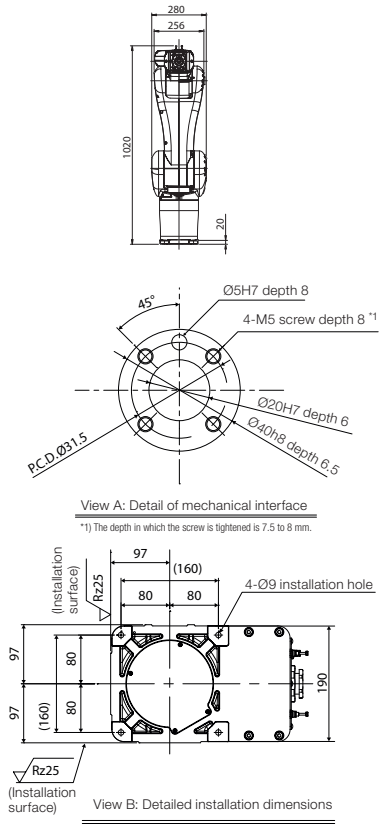

RV-12CRL

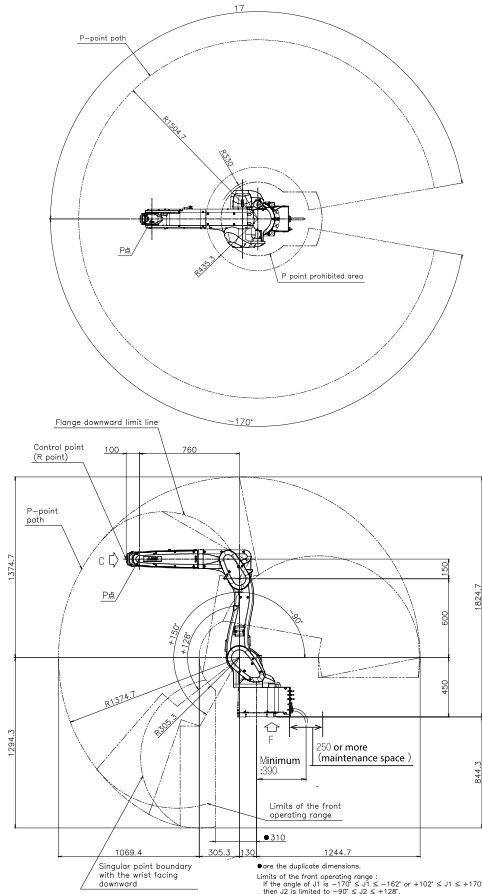
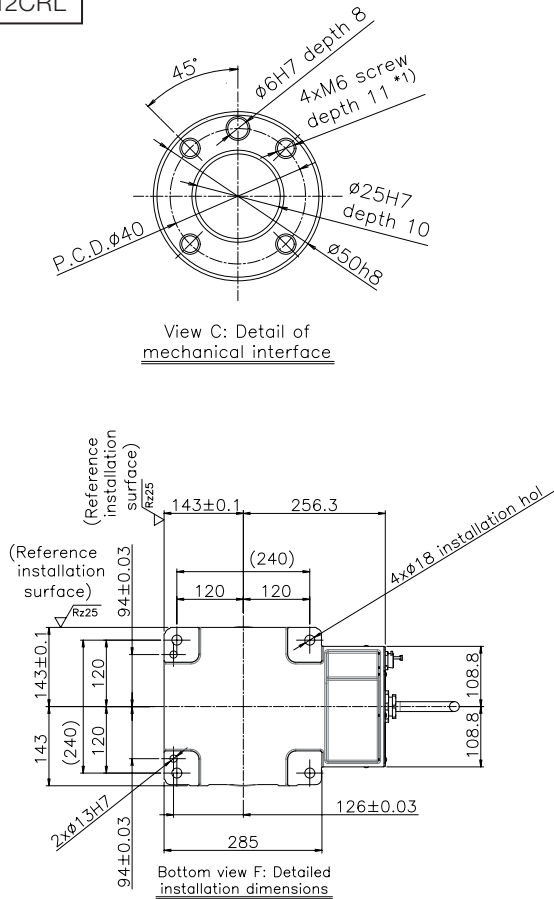

Industrial robots RH-1FRHR



SCARA robot for overhead installation

With its special compact design and support for overhead installation above the application, the robot RH-1FRHR doesn't take up any valuable space in the work area next to the installation location, enabling even smaller work cell dimensions.

The RH-1FRHR5515 is a high-speed robot dedicated for the handling of small parts up to 1 kg. Up to 150 picks/min with conveyor tracking including hand open/close are possible.

Highlights:

- High-speed 4 axis robots for fastest pick and place (cycle times of only 0.28 s)
- Up to 150 picks/min. with conveyor tracking including hand open/close
- Space saving and flexible installation method
- Optionally integrated vacuum valve and bellow for highest requirements in pharmaceutical and F&B application

Characteristics/Functions		Specifications	
		RH-1FRHR5515-D	RH-1FRHR5515-R
Degrees of freedom (no. of axes)		4	
Installation posture		On floor, ceiling mounting, wall mounting	
Structure		Horizontal articulated arm	
Drive system		AC servo	
Position detection method		Absolute encoder	
Brake attachment		Axes J1, J2, J4: no brake; axis J3: with brake	
Payload capacity	rated	1	
	maximum	3	
Maximum reach		mm	550
Operating range	J1	degree	±177
	J2	degree	±145
	J3 (Z)	mm	150
	J4 (Θ axis)	degree	±360
Maximum speed	J1	degree/s	337.5
	J2	degree/s	720
	J3 (Z)	mm/s	765
	J4 (Θ axis)	degree/s	3000
Maximum composite speed		mm/s	6267
Cycle time (25x300x25 mm with 1 kg load)		sec	0.28
Allowable wrist moment of inertia	rated	kgm ²	0.005
	maximum		0.005
Position repeatability	X, Y direction	mm	±0.012
	J3 (Z direction)	mm	±0.01
	J4 (Θ axis)	degree	±0.004
Ambient temperature		°C	0–40
Weight		kg	49
Tool wiring	Hand: 8 inputs/8 outputs, 8 signal cables		
Tool pneumatic pipes	Primary: Ø 6x2 (secondary: Ø 4x8 by option)		
Supply pneumatic pressure		MPa	5 ±10 % for the pneumatic gripper
Protection rating	IP20 (IP65/ISO class 5 with additional bellow)		
Robot controller			CR800-D CR800-R + R16RTCPU
Order information		Art. no.	312997 313661

Additional models without standard 5m machine cable are available.

Robot arms RH-1FRHR

RH-1FRHR

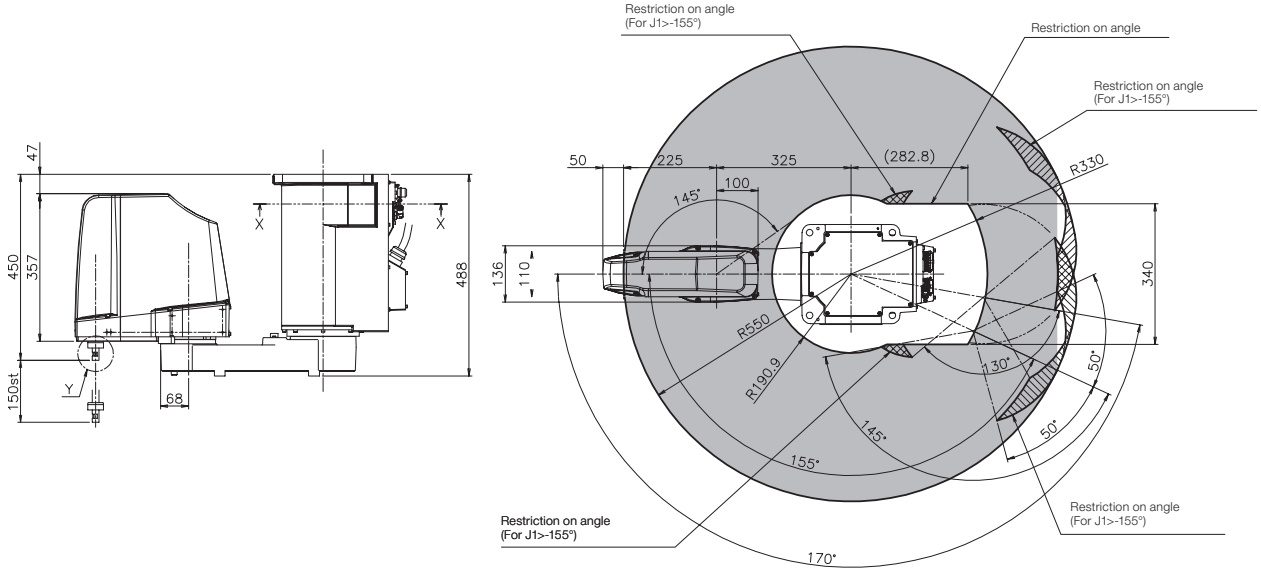

Dimensions: mm

Industrial robots RH-3FRHR



RH-3FRHR

The SCARA robots RH-3FRHR

With its special compact design and support for overhead installation above the application, the robot RH-3FRHR doesn't take up any valuable space in the work area next to the installation location, enabling even smaller work cell dimensions. The robot's perfectly circular cylindrical workspace is 150 mm high with a diameter of 700 mm. It can access any point in this space with a repeatability of just ± 0.01 mm while manipulating a payload of up to 3 kg.

Highlights:

- Overhead installation for minimum space requirements
- Only 24 kg weight
- Cycle times of only 0.32 s
- High stability due to compact design
- Pneumatic hoses and signal wires are routed inside the robot

Characteristics/Functions	Specifications	
	RH-3FRHR3515-D-S25	RH-3FRHR3515-R-S25
Degrees of freedom (no. of axes)	4	
Installation posture	Overhead	
Structure	Horizontal articulated arm	
Drive system	AC servo	
Position detection method	Absolute encoder	
Brake attachment	Axes J1, J2, J4: no brake; axis J3: with brake	
Payload capacity	rated	1
	maximum	3
Maximum reach	arm 1 + arm 2	350
		mm
Operating range	J1	degree
	J2	degree
	J3 (Z)	mm
	J4 (Θ axis)	degree
Maximum speed	J1	degree/s
	J2	degree/s
	J3 (Z)	mm/s
	J4 (Θ axis)	degree/s
Maximum composite speed	mm/s	6267 (J1, J2)
Cycle time (25x300x25 mm with 1 kg load)	sec	0.32
Allowable wrist moment of inertia	rated	0.005
	maximum	0.05
Position repeatability	X, Y direction	mm
	J3 (Z direction)	mm
	J4 (Θ axis)	degree
Ambient temperature	$^{\circ}\text{C}$	0–40
Weight	kg	24
Tool wiring	Input 8 points/output 8 points (option: output 8 points), 8 spare wires	
Tool pneumatic pipes	Primary: \varnothing 6x2 (secondary: \varnothing 4x8 by option)	
Supply pneumatic pressure	MPa	5 ± 10 % for the pneumatic gripper
Protection rating	IP20	
Robot controller	CR800-D	CR800-R + R16RTCPU
Order information	Art. no.	
	312998	314028

Please contact your Mitsubishi Electric representative for IP65 and cleanroom models. Additional models without standard 5m machine cable are available.

Robot arms RH-3FRHR

RH-3FRHR

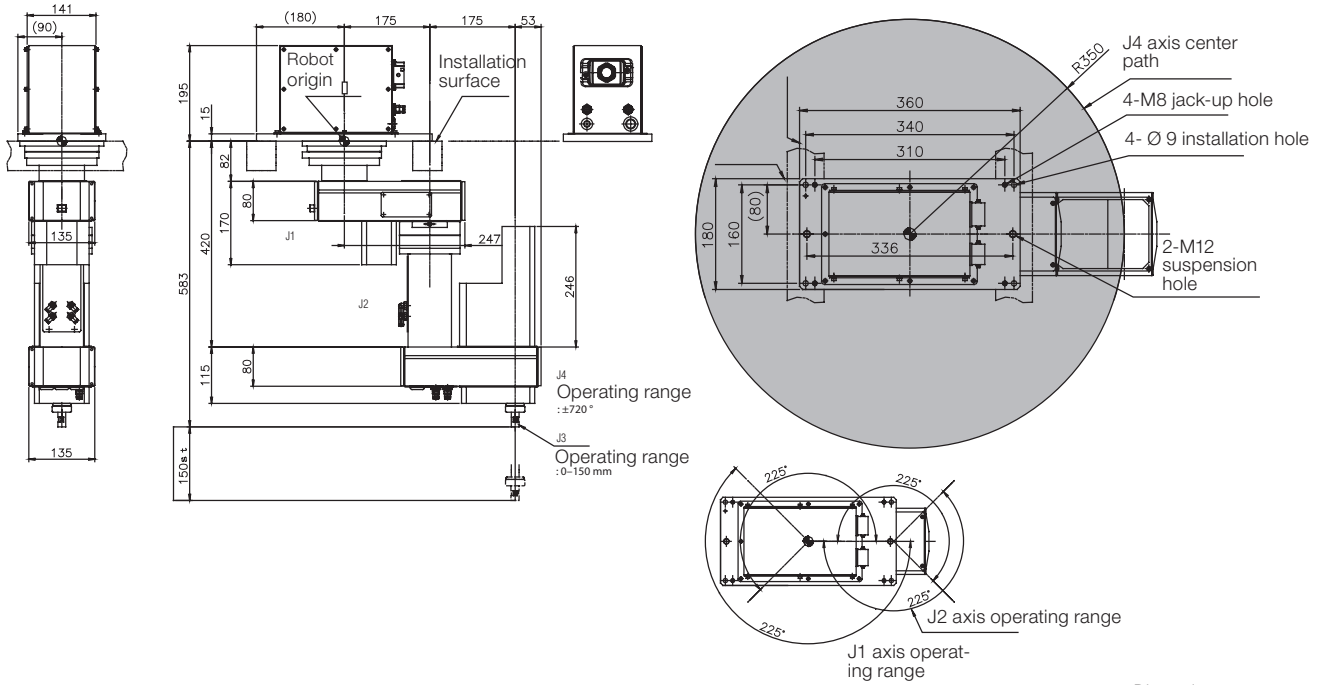

Industrial robots RH-FRH



RH-12FRH



RH-6FRH

The SCARA robots RH-FRH

SCARA robots are ideal for sorting, palletizing and component installation due to their short cycle time. The robots of the RH-FR series achieve the highest speeds in their class thanks to the new motors developed by Mitsubishi Electric, high arm rigidity, and unique control technology.

The resulting reduced cycle time of only 0.29 seconds for a 12" cycle make for significantly increased productivity and improved continuous operation.

Highlights:

- Connections for pneumatic grippers, Ethernet, USB, tracking func-

tions, camera interface, hand I/O, additional axis controller and an interface for GOT HMIs.

- Fully enclosed cabling to end of spindle for protection and safety
- RH-6/12/20FRH has the tried-and-tested protection class IP54 (IP65 optional)

Characteristics/Functions			Specifications				
			RH-3FRH5515-D/ RH-3FRH5515-R	RH-6FRH5520N-D/ RH-6FRH5520N-R	RH-12FRH8535N-D/ RH-12FRH8535N-R	RH-20FRH10035N-D/ RH-20FRH10035N-R	
Degrees of freedom (no. of axes)			4				
Installation posture			Floor mounting				
Structure			Horizontal articulated arm				
Drive system			AC servo				
Position detection method			Absolute encoder				
Brake attachment			Axes J1, J2, J4: no brake; axis J3: with brake				
Payload capacity	rated	kg	1	3		5	
	maximum		3	6	12	20	
Maximum reach	arm 1 + arm 2		550	550	850	1000	
Operating range	J1	degree	340 (±170)				
	J2	degree	290 (±145)			306 (±153)	
	J3 (Z)	mm	150	200	350		
	J4 (Θ axis)	degree	720 (±360)				
Maximum speed	J1	degree/s	400			280	
	J2	degree/s	720			670	
	J3 (Z)	mm/s	1100	2400	2800	2400	
	J4 (Θ axis)	degree/s	3000	2500	2400	1700	
Maximum composite speed		mm/s	8300			11350	
Cycle time (25x300x25 mm with max. 2 kg load)		sec	0.51	0.29	0.30	0.36	
Allowable wrist moment of inertia	rated	kgm ²	0.005	0.01	0.025	0.065	
	maximum		0.06	0.12	0.3	1.05	
Position repeatability	X, Y direction		±0.012			±0.015	
	J3 (Z direction)		±0.010				
	J4 (Θ axis)		±0.004			±0.005	
Ambient temperature		°C	0-40				
Weight		kg	32	37	69	77	
Tool wiring			Input 8 points/output 8 points (total 20 scores)				
Tool pneumatic pipes			Primary: Ø 6x2, secondary: Ø 4x8				
Supply pneumatic pressure			MPa 5 ±10 % for the pneumatic gripper				
Protection rating			IP20		IP54 (IP65 with additional bellow)		
Robot controller			CR800-D/CR800-R + R16RTCPU				
Order information			Art. no.	312930/ 313651	312985/ 313666	312991/ 313672	312995/ 313676

Please contact your Mitsubishi Electric representative for ESD and cleanroom models. Additional models without standard 5m machine cable are available.

Dimensions and movement ranges

RH-12FRH/20FRH

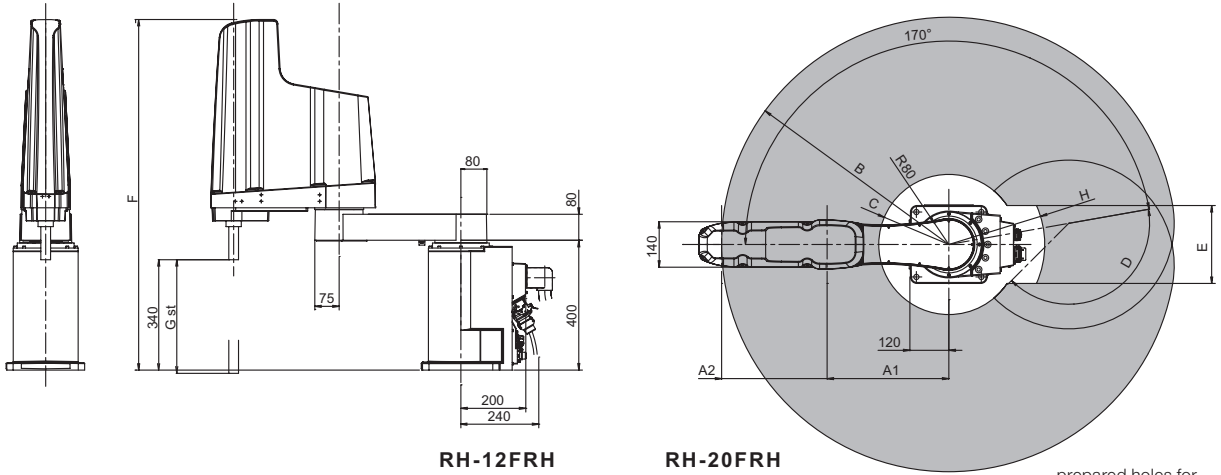

RH-12FRH

RH-20FRH

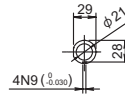
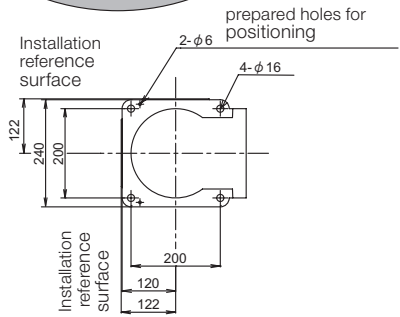
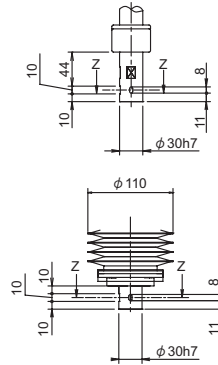
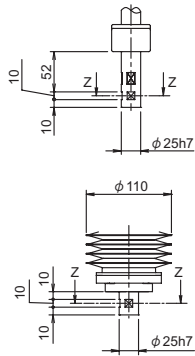

Dimensions: mm

Variable dimensions

Robot series	A1	A2	B	C	D	E	F	G	H
RH-12FRH/20FRH8535	525	325	R850	R278	153°	—	1080/1180	350/340	—
RH-20FRH10035	525	475	R1000	R238	153°	240	1080/1180	350/340	R295

Industrial robots RH-CRH

The SCARA robots RH-CRH

These robots expand the Mitsubishi Electric SCARA robot product portfolio and are perfect for pick & place, assembly and conveyor tracking applications where a cost-efficient solution is required. Thanks to their compact design and large working area, the RH-CRH robots are suitable for a wide range of applications. Servo motor with battery-less absolute encoder ensure easy maintenance and stress-free operation



RH-3CRH

Highlights:

- Compact arm for space saving
- Lightweight robot arms
- High-speed operation and high performance for productivity
- Excellent cost performance
- MELFA SafePlus option supports safety monitoring functions and can directly handle the safety logic in the robot controller without using a safety PLC
- I/O option card 2D-TZ378 with 32 inputs/32 outputs is included

Characteristics/Functions			Specifications		
			RH-3CRH4018-D-S15	RH-6CRH6020-D-S15	RH-6CRH7020-D-S15
Degrees of freedom (no. of axes)			4		
Installation posture			Floor mounting		
Structure			Horizontal articulated arm		
Drive system			AC servo		
Position detection method			Absolute encoder		
Brake attachment			Axes J1, J2: no brake; axes J3, J4: with brake		
Payload capacity	rated	kg	1	2	
	maximum		3	6	
Maximum reach			400	600	700
Operating range	J1	degree	264 (±132)		
	J2	degree	282 (±141)		
	J3 (Z)	mm	180	200	
	J4 (θ axis)	degree	720 (±360)		
Maximum speed	J1	degree/s	720	420	360
	J2	degree/s	720		
	J3	mm/s	1100		
	J4	degree/s	2600	2500	
	J1+J2	mm/s	7200	7800	
Cycle time (25x300x25 mm with 1 kg load)			0.44	0.41	0.43
Allowable wrist moment of inertia	rated		0.005	0.01	
	maximum	kgm ²	0.05 (0.075)	0.12 (0.18)	
Position repeatability	X, Y direction	mm	±0.01		
	J3 (Z direction)	mm	±0.01		
	J4 (θ axis)	degree	±0.01		
Ambient temperature			°C 0-40		
Weight			14	17	18
Tool wiring			15-pins, D-sub		
Tool pneumatic pipes			Ø 6x2, Ø 4x1		
Supply pneumatic pressure			MPa 0.5 ±10 %		
Protection rating			IP20		
Robot controller			CR800-D		
Order information			Art. no. 500837	500838	500839

Please contact your Mitsubishi Electric representative for models with installed bellows

Specifications

Characteristics/Functions	Specifications					
	RH-10CRH6020-D-S15 RH-10CRH6030-D-S15	RH-10CRH7020-D-S15 RH-10CRH7030-D-S15	RH-10CRH8020-D-S15 RH-10CRH8030-D-S15	RH-20CRH8542-D-S15	RH-20CRH10042-D-S15	
Degrees of freedom (no. of axes)	4					
Installation posture	Floor mounting					
Structure	Horizontal articulated arm					
Drive system	AC servo					
Position detection method	Absolute encoder					
Brake attachment	Axes J1, J2: no brake; axes J3, J4: with brake					
Payload capacity	rated	5				10
	maximum	10				20
Maximum reach	mm		600	700	800	850 1000
	J1	degree	264 (±132)			340 (±170)
Operating range	J2	degree	300 (±150)			290 (±145) 306 (±153)
	J3 (Z)	mm	200 300			420
	J4 (Θ axis)	degree	720 (±360)			
Maximum speed	J1	degree/s	420			375
	J2	degree/s	720			600
	J3	mm/s	1100			2300
	J4	degree/s	2700			1600
Cycle time (25x300x25 mm with 1 kg load)	sec		0.41	0.42	0.37	
	Allowable wrist moment of inertia	rated	0.02			
maximum		kgm ²	0.3			
Position repeatability	X, Y direction	mm	±0.02		±0.025	±0.025
	J3 (Z direction)	mm	±0.01			
	J4 (Θ axis)	degree	±0.01			
Ambient temperature	°C		0–40			
Weight	kg		20		21	54 57
Tool wiring	15-pins, D-sub				15-pins & 9pins, D-sub	
Tool pneumatic pipes	Ø 6x2, Ø 4x1				Ø 8x2, Ø 6x2	
Supply pneumatic pressure	MPa		0.5 ±10 %			
Protection rating	IP20					
Robot controller	CR800-D					
Order information	Art. no.	732974 732977	732975 732978	732976 732979	732980	732981

Dimensions and movement ranges

Robot arms RH-CRH

RH-3CRH

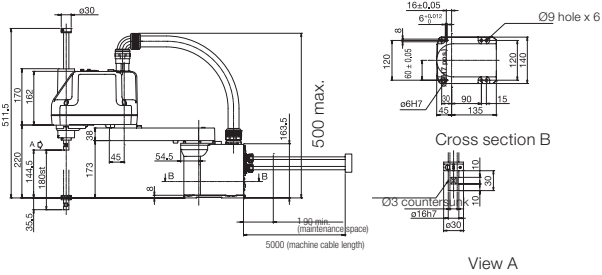

View A

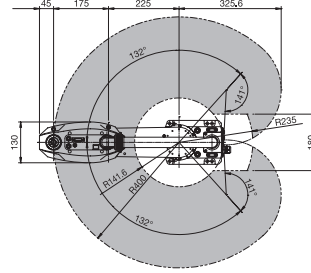

RH-6CRH

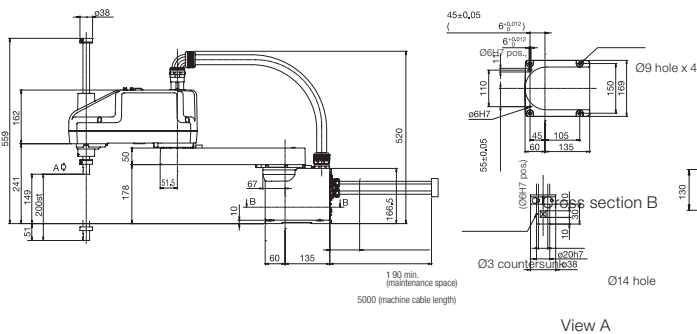

View A

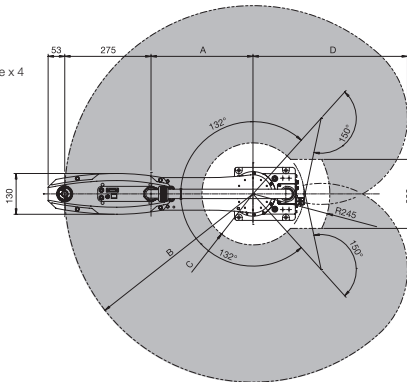

Variable dimensions

Robot series	A	B	C	D
RH-6CRH6020	325	R600	R162.6	492.5
RH-6CRH7020	425	R700	R232	559.4

This is the space required for battery replacement, and indicates the dimensions including the minimum bending radius of the machine cable.

Dimensions: mm

RH-10CRH

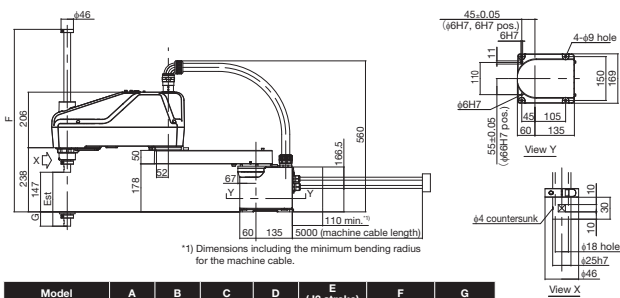

*1) Dimensions including the minimum bending radius for the machine cable.

Model	A	B	C	D	E (J3 stroke)	F	G
RH-10CRH60XX	225	R600	R212.4	525.6	200/300	577/677	53/153
RH-10CRH70XX	325	R700	R187.5	592.5	200/300	577/677	53/153
RH-10CRH80XX	425	R800	R212.6	659.4	200/300	577/677	53/153

RH-20CRH

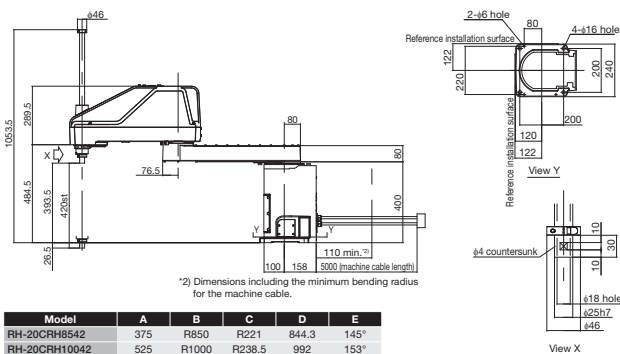

*2) Dimensions including the minimum bending radius for the machine cable.

Model	A	B	C	D	E
RH-20CRH8542	375	R850	R221	844.3	145°
RH-20CRH10042	525	R1000	R238.5	992	153°

(Unit: mm)

FR-D series system configuration

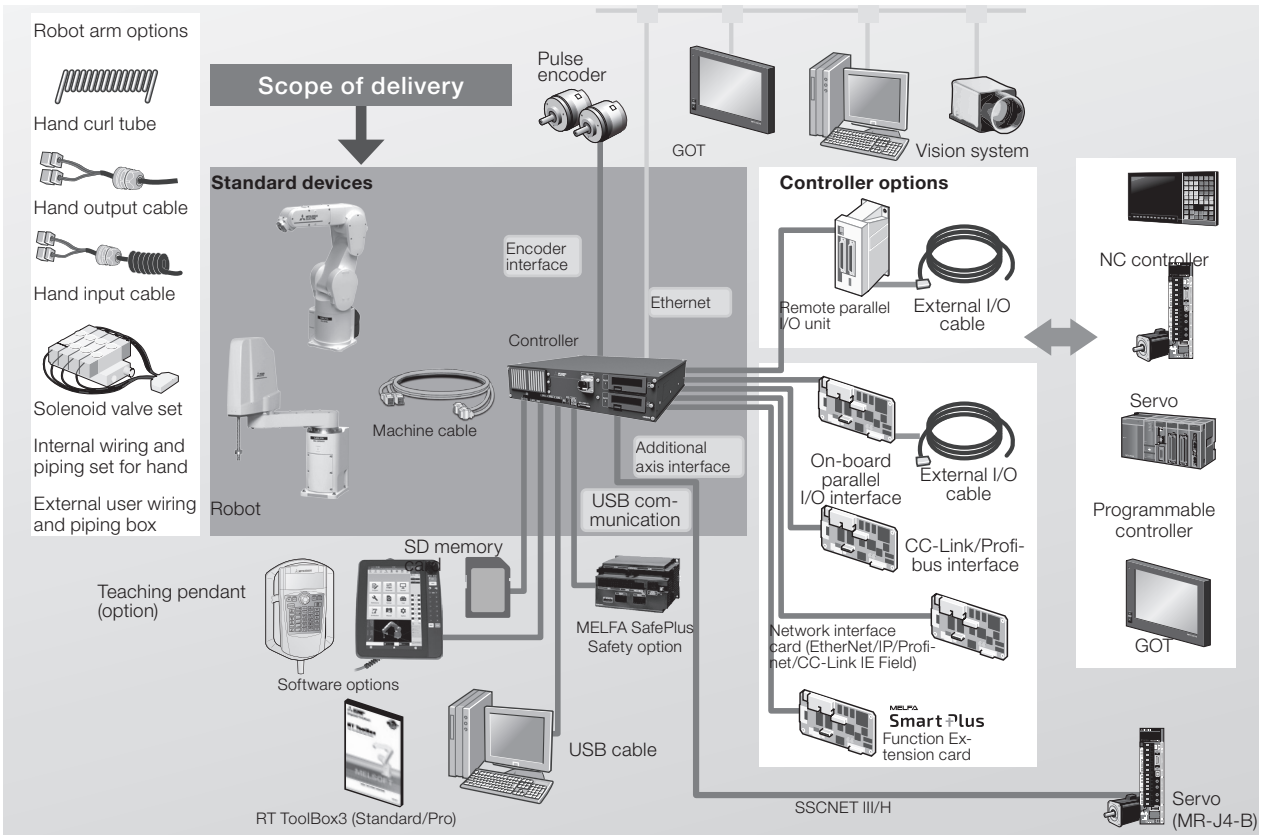

FR-R series system configuration (iQ-R Platform)

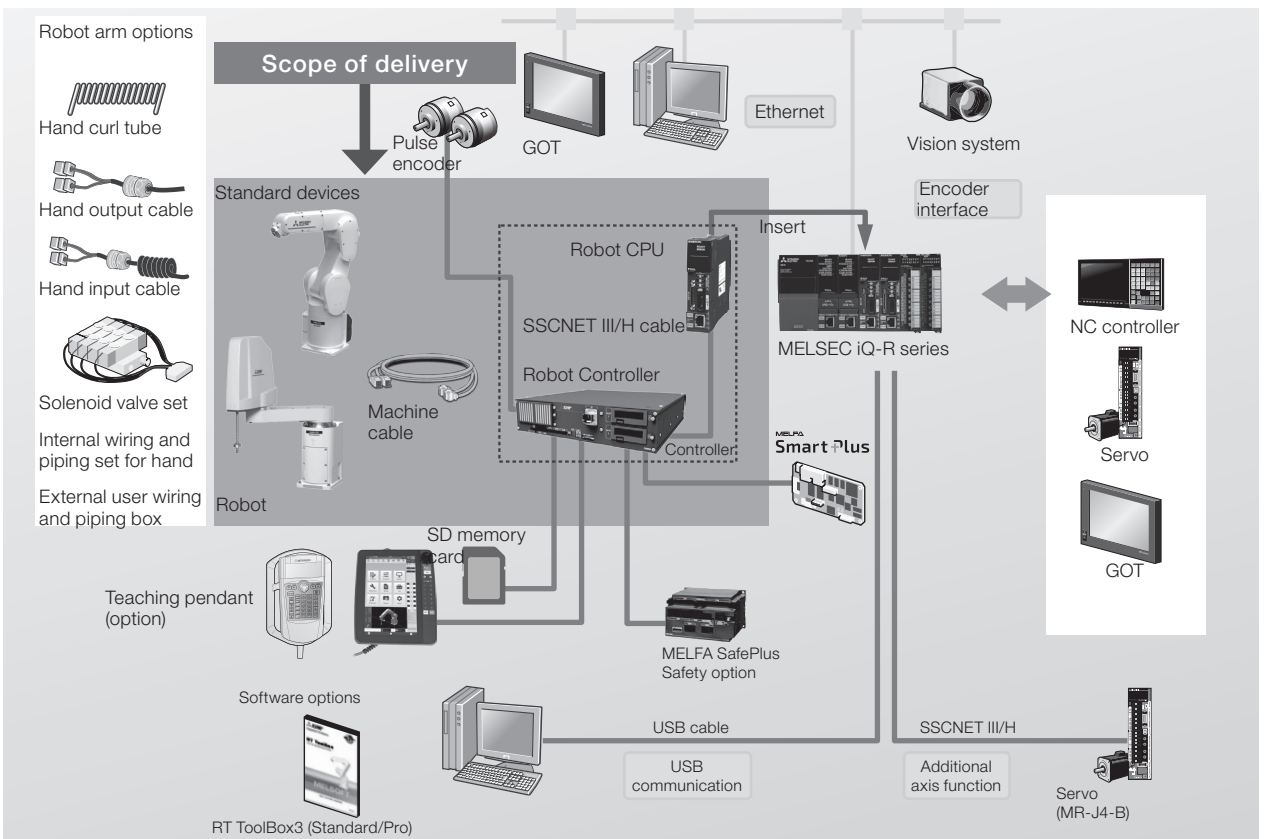

Controller specifications



Controller CR800

Powerful controller

Every robot system has its own compact, modular robot controller, which contains the CPU and the power electronics for controlling the robot.

Mitsubishi Electric's robot controllers have a particularly slim, compact design. No matter which MELFA robot you use the programming language and options are always the same. You can add special application functions by inserting expansion option cards in the slots in the controllers. Therefore it is possible, to integrate the controller into different types of networks.

All controllers have already implemented functions like Ethernet and USB connection, additional axes control over SSCNET III/H and tracking encoder interface as a standard.

The control unit CR800 also includes the input and output card for the connection of a pneumatic or electric gripper.

Characteristics/Functions	CR800-D	CR800-R	
Shipped with robot	RV-2FR/2FRL/4FR/4FRL/7FR/7FRL/7FRLL/13FR/13FRL/20FR/RV-5AS/RV-8CRL/RV-12CRL		
Robot CPU	—	R16RTCPU	
Path control method	PTP control and CP control		
Number of controllable axes	6 robot axes + 2 interpolation axes + 6 independent axes		
Programming language	MELFA-BASIC V/VI		
Position teaching method	Teaching method, MDI method		
Memory capacity	no. of teaching points	39000	
	no. program steps	78000	
	no. of programs	512	
External inputs/ outputs	general purpose I/Os	Up to 256 optional	Up to 8192 shared with PLC CPU
	dedicated I/Os	Assigned to general-purpose I/O	Assigned to multiple CPU common device
	hand open/close	8 inputs/8 outputs	
	emergency stop I/Os	1 (redundant)	
	door switch input	1 (redundant)	
	enabling device input	—	
	mode output	1 (redundant)	
	robot error output	1 (redundant)	
	synchronization of additional axes	1 (redundant)	
	Ethernet	1 (10BASE-T/ 100BASE-TX/1000BASE-T)	
USB	1 (Ver. 2.0 device functions only, mini B terminal)	1 (USB port of programmable controller CPU unit can be used.)	
SD memory slot	1		
Ambient temperature	°C 0–40		
Relative humidity	% RH 45–85		
Power supply	input voltage range	RV-2F(L)/4F(L)/7F(L), RH-1FRHR/3FRH/3FRHR/6FRH/12FRH/20FRH: 1-phase 180–253 V AC RV-7FRLL/13FR(L)/20FR: 3-phase 180–253 V AC or 1-phase 207–253 V AC RV-5AS: 1-phase 100–120 V AC (200–230 V AC), RV-8CRL, RH-CRH: 200–230 V AC	
	power capacity	RV-2FR(L), RH-3FRH, RH-3CRH/6CRH: 0.5; RV-4FR(L), RH-3FRHR/6FRH, RV-5AS: 1.0; RH-1FRHR/12FRH/20FRH, RH-10CRH/20CRH: 1.5; RV-7FR(L), RV-8CRL: 2.0; RV-7FRLL/13FR(L)/20FR: 3.0	
Dimensions (WxHxD) including legs	mm 430x99.5x425		
Weight	kg 12.5		
Structure (protective specification)	Self-contained floor type/open structure (Vertical and horizontal position can be placed) (IP20) + IP54 protection box available as an option		
Grounding	Ω 100 or less (class D grounding)		

Robot controller

Characteristics/Functions		CR860-D	CR860-R
Shipped with robot		RV-35FR/50FR/80FR	
Robot CPU		Built-in	R16RTCPU
Path control method		PTP control and CP control	
Number of controllable axes		6 robot axes + 2 interpolation axes + 6 independent axes	
Programming language		MELFA-BASIC V/VI	
Position teaching method		Teaching method, MDI method	
Memory capacity	no. of teaching points	39000	
	no. program steps	78000	
	no. of programs	512	
External inputs/ outputs	general purpose I/Os	Up to 256 optional	Up to 8192 shared with PLC CPU
	dedicated I/Os	Assigned to general-purpose I/O	Assigned to multiple CPU common device
	hand open/close	12 inputs/8 outputs	
	emergency stop I/Os	1 (redundant)	
	door switch input	1 (redundant)	
	enabling device input	1 (redundant)	
	mode output	1 (redundant)	
	robot error output	1 (redundant)	
	synchronization of additional axes	1 (redundant)	
Ethernet	Ethernet	1 (10BASE-T/ 100BASE-TX/1000BASE-T)	
	USB	1 (Ver. 2.0 device functions only, mini B terminal)	1 (USB port of programmable controller CPU unit)
Machine cable	included fixed type	m	7
	option fixed type	m	12, 17, 22
	option flexible type	m	7, 12, 17, 22
Ambient temperature	°C	0–45	
Relative humidity	% RH	10–85	
Power supply	input voltage range	V	3 phase 378-462 V AC with transformer unit
	power capacity	kVA	10
Dimensions (WxHxD)	controller	mm	670x670x500
	transformer unit	mm	670x515x502
Weight	controller	kg	80
	transformer unit	kg	120
Structure (protective specification)		Self-contained floor type/Enclose type IP54 (Fan part: IP2X)	
Grounding		Ω	100 or less (class D grounding)

Controller dimensions

CR800

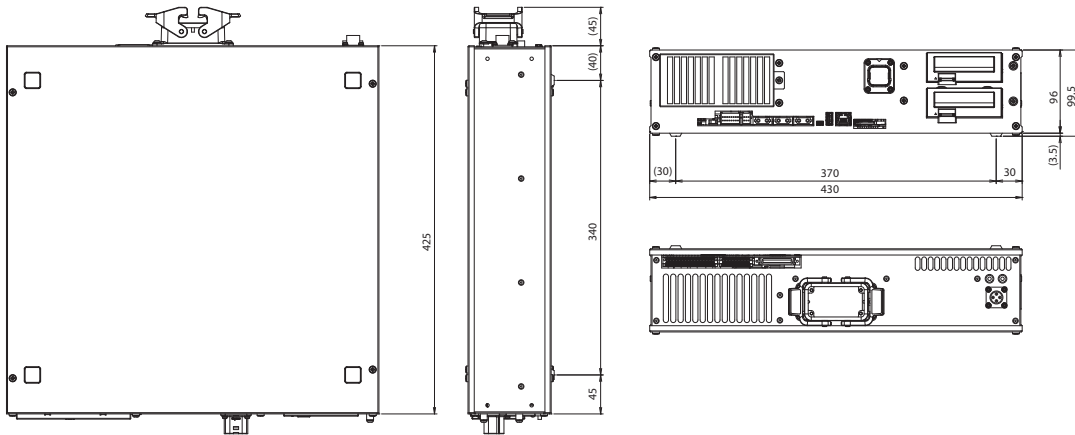

CR860 Controller

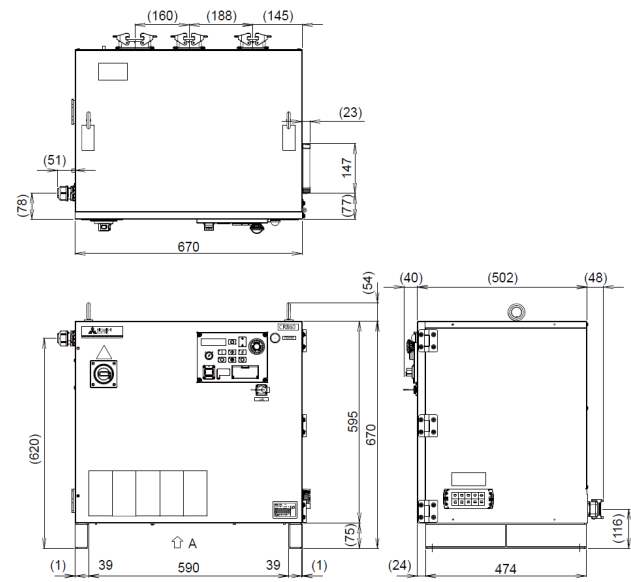

CR860 Transformer Unit

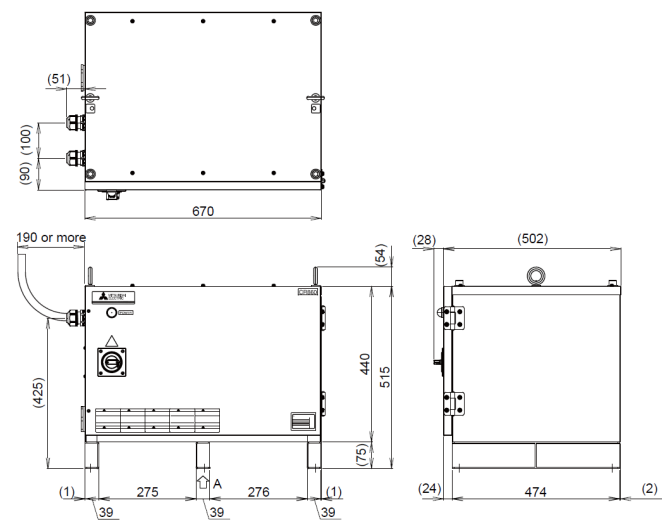

Teaching box for the robot series



R86TB



R32TB

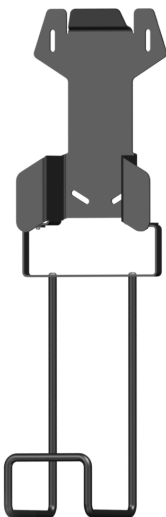

R86TB wall mount

Operation and programming

The High-Performance Teaching Box (R86TB) offers a comprehensive solution that combines enhanced functionality, easiness to use and cost reduction. Making your automation processes more efficient and cost-effective.

Improved processing speed and large 10.1" high-definition display allows stress-free and flexible operability. The TB offers still secure physical buttons for tactile and consistent operation.

Equipped with major functions of robot engineering software RT Tool-box3, allows users quickly leverage their existing knowledge and skills when using R86TB.

The R86TB includes a state-of-the-art 3D monitor with display layouts created by RT3. The robot's movement can be visualized and checked in a 3D mode.

Specifications	R86TB	R32TB	
Compatibility	RV series/RH series	RV series/RH series	
Functions	Operation, programming and monitoring of all robot functions		
Programming and monitoring	Read out information, also during operation; program editing with the easy edit function and templates for further efficient setup; visualization of setting areas on the 3D monitor screen; data analysis ways provided for troubleshooting	Read out information, also during operation, program editing with T9-Key standard, supervising of I/Os, display of error alarms, right-/left-Hand usage, 36 keys for operation selection	
Software	Integrated operating system software with menu-based user interface		
Menu navigation (language)	English, Japanese, Chinese	English, Japanese	
Display	type/dimensions	10,1" TFT display (800x1280 pixels)	Monochrome LCD graphic display (24 characters x 8 lines)
	technology	Touchscreen with backlight	LCD with backlight
Interfaces	USB, Ethernet for connection to the robot controller	RS422 for connection to the robot controller	
Connection	Connected with the controller using a dedicated connector, Cable length: 7m		
Protection rating	IP65		
Weight	kg 1.2	0.9	
Order information Art. no.	687249	214968	

Accessories	2F-TBSTS-01, 2F-TBEMGSTS-01	Wall Mount R86TB	Wall Mount R32TB
Application	TB-Safety box for EMG output signals of TB	Option for wall mount of TB with cable hanger	
Order information Art. no.	279057 683882	699067	274317

Force sensor



Force sensor set

With the force sensor, our RV series and RH series robots can be controlled to reach pre-set values of reaction force and softness when the robot contacts surrounding objects.

Features

- Function for controlling robots while applying a specified force
- Function for controlling the stiffness of robot appendages
- Function for changing control characteristics while the robot is running
- Function for acquiring force sensor and robot positions while contact made

- Function for display force sensor data and maintaining maximum values
- Function for acquiring force sensor information synchronized to position
- Information as log data and displaying it in graph form
- Allows logging start/stop commands to be specified in robot programs
- Function for transferring acquired log files to the FTP server

Specifications	4F-FS002H-W200	4F-FS002H-W1000
Robots	RV series/RH series	
Controller	CR800-D/R	
Max. static load (Fx, Fy, Fz / Mx, My, Mz)	200N/4Nm	1000N/30Nm
Set includes:	Force sensor, Force sensor interface unit, Sensor attachment adapter, Adapter cable for internal wiring, 24 V DC Power supply incl. 1 m cable, Serial cable between unit and sensor 5 m, SSCNET III cable 10 m	
Order information Art. no.	313064	313105

MELFA SafePlus



“MELFA SafePlus” safety technology for robot controllers

Functions like reduced safe speed control, safe limited control range, and safe torque monitoring are the main functions which can be activated via safety inputs, as a result, the robots can be easily integrated into safety systems.

Simple safety logic to control safety I/Os can be programmed in the robot controller without using a dedicated Safety PLC.

Specifications	4F-SF002-01	4F-SF003-05
Robots	RV series/RH series	RV series/RH series
Controller	CR800-D/R	CR800-D/R/Q/CR860-D/R
Redundant safety in-/outputs	8 inputs/4 outputs	8 inputs/4 outputs
Order information Art. no.	313061	603944

Accessories	2F-SFDCIN-CBL02-OEM	2F-SFSDI-CBL02-OEM	2F-SFSDO-CBL02-OEM	2F-SFRIO-CBL05-OEM
Application	DCIN cable for 4F-SF002-01	SDI cable (1 safety input) for 4F-SF002-01	SDO cable (4 safety outputs) for 4F-SF002-01	RIO cable for 4F-SF002-01
Length	m	2		5
Order information Art. no.	413838	413839	413840	470795

MELFA Smart Plus card and MELFA Smart Plus card pack

▪ MELFA Smart Plus card and MELFA Smart Plus card pack



Advanced intelligent functions are provided by MELFA Smart Plus

The MELFA Smart Plus card pack and the MELFA Smart Plus card with upgraded predictive-maintenance and enhanced force-sensor functions for upgraded functionality in MELFA-FR series industrial robots incorporate Mitsubishi Electric's original compact AI technology, Maisart®, to realize 60 % reductions in both takt time and system startup time to contribute to increased

productivity at manufacturing sites.

Integrated functions for the various sensors and autonomous startup adjustment functions are included:

- Robot mechanism temperature compensation function
- Calibration assistance function
- Coordinated control for additional axes

Specifications	MELFA Smart Plus card pack		MELFA Smart Plus card	
	2F-DQ510	2F-DQ520	2F-DQ511	2F-DQ521
Robots	RV-FR (except RV-35/50/80FR) and RH-FR, RV-8CRL		RV-FR (except RV-35/50/80FR) and RH-FR, RV-8CRL	
Controller	CR800-D/R			
Number of functions enabled	All type A functions	All type A and B functions	1 type A function	1 type B function
Order information Art. no.	325728	486379	325729	486380

	Function	Function outline
Type A – Intelligent functions	Calibration assistance function <ul style="list-style-type: none"> ▪ Automatic calibration ▪ Work coordinate calibration ▪ Relative position calibration 	Supports calibration of position with other equipment using 2D vision sensor <ul style="list-style-type: none"> ▪ Automatically corrects vision sensor coordinates to improve positional accuracy ▪ Corrects robot and workpiece coordinates using vision sensor to improve positional accuracy ▪ Correct positions between multiple robots using vision sensor Improve positional accuracy of coordinated actions
	Robot mechanism thermal compensation function	Compensate for thermal expansion of robot arm to improve positional accuracy
	Coordinated control of additional axes	Perform high-accuracy coordinated (interpolation) work with additional axes (direct coaxial)
	Preventive maintenance function (Maintenance simulation, wear calculation function)	Maintenance simulation of the robot through real-time analysis of the robot programme
Type B – AI functions	MELFA-3D Vision enhancement function	Utilizes AI technology to automate 3D vision sensor adjustments and improve measurement and recognition performance
	Enhancement function for force sense control	Utilizes AI technology for repeated learning in short time periods and to calculate optimal insertion patterns
	Predictive Maintenance (incl. Preventive Maintenance function)	Quickly detects abnormalities in drive system components at an early stage to reduce the downtime

Internal/external wiring



Internal wiring/piping set for hand

This set consists of hand input cables and hoses that can be routed through the spindle until the end of the arm 2.

A bracket to fix the set on the arm 2 is included. The set can be used with an optional solenoid valve.

Specifications	1F-HS304S-01	1F-HS408S-01	1F-HS604S-01
Robots	RH-1FRHR/RH-3FRH	RH-6FRH	RH-12FRH/20FRH
Stroke	mm —	200	350
Length from the shaft end	mm 300		400
Attachment	4 air hoses (Ø 3), 8 hand input cables (0.2 mm ²) 2 power cables (0.3 mm ²)	4 air hoses (Ø 4), 8 hand input cables (0.2 mm ²) 2 power cables (0.3 mm ²)	4 air hoses (Ø 6), 8 hand input cables (0.2 mm ²) 2 power cables (0.3 mm ²)
Remarks	Both ends are free. Eight reducers (Ø 3 to Ø 4) are attached. The robot arm side is connector (HC1, HC2), and one side is free.	Both ends are free. The robot arm side is connector (HC1, HC2), and one side is free.	
Weight	kg 0.4		
Order information	Art. no. 250468	250469	254396

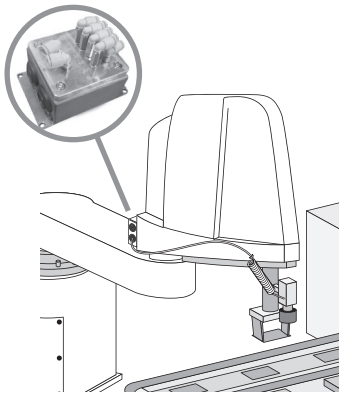

External wiring/piping box

With this option hand output and input cables and pneumatic hoses can be routed from the back of arm 2 to the spindle end outside the robot casing. Connections for connecting the external hoses and brackets

for attaching the cables and hoses are included. The option can also be used for oil mist and cleanroom models. A bracket to fix the set on the arm 2 is included. The set can be used with an optional solenoid valve.

Specifications	1F-UT-BOX	1F-UT-BOX-01
Robots	RH-3FRH/6FRH	RH-12FRH/20FRH
Attachment	Eight air hoses (connect to solenoid valve) Installation screws (conical spring washer, plain washer)	
Weight	kg 0.5	
Order information	Art. no. 251104	254398

Pulled out from robot arm

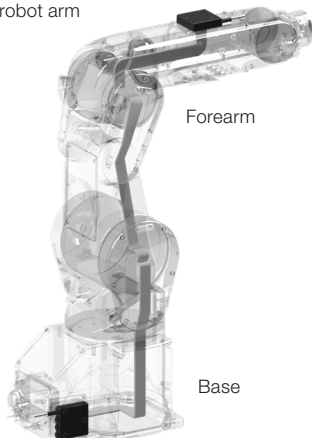

Forearm external wiring set/base external wiring set

With these options the hand input signal cables and the communication cables etc. can be led out of the bottom of the forearm and from the side of the base.

Use the recommended pairing in the table to led out the same cables on the arm side and at the base.

Specifications	1F-HB01S-01	1F-HA01S-01
Robots	RV-4FRL/7FR/7FRL/7FRLL/13FR/13FRL/20FR	
Part name	Forearm external wiring set	Base external wiring set
Hand input signal cable	8	—
Ethernet cable	1	
Additional cable	4	
Recommended pairing	●	
Order information	Art. no. 257936	257935

Valve sets, bellows

Solenoid valve sets

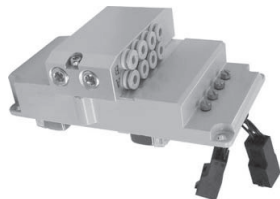

Solenoid gripper control valve sets

This option is used to control the gripper tool installed on the robot arm. The valve set comes with all the components required for installation, including the branch manifold, couplings and dampers.

The valves are fitted with plug-in control cables for quick and easy wiring. The solenoid valve sets are for use with oil-free compressed air.

Specifications	1F-VV0□ E-01		1E-VV0□ E		
	1	2	1	2	
No. of valves	1	2	1	2	
Range of use (robot type)	RH-1FHR		RV-2FR(B)/RV-2FRL(B)		
Valve function	Vacuum valve		Double solenoid		
Operating method	Two-stage ejector		Internal pilot method		
Effective sectional area (CV value)	1.5 mm		1.5 mm		
Operating pressure range	3–6 bar		2–7 bar		
Maximum pressure	10 bar		10 bar		
Response time	<2.5 ms at 24 V DC		<12 ms at 24 V DC		
Max. operating frequency	5 Hz		5 Hz		
Ambient temperature	-5–50 °C		-10–50 °C		
Coil rated voltage	24 V DC ±10 %		24 V DC ±10 %		
Order information	Art. no.	277712	277713	47397	47398

Specifications	1S-VV0□ E-05	1F-VV0□ E-01				1S-VV0□ E-01				1F-VV0□ E-02				1F-VV0□ E-03				
	4	1	2	3	4	1	2	3	4	1	2	3	4	1	2	3	4	
No. of valves	4	1	2	3	4	1	2	3	4	1	2	3	4	1	2	3	4	
Range of use (see page)	RH-3FRHR	RV-5AS (only 1 and 2 valves) RH-1FRHR, RH-3FRH, RH-6FRH				RH-12/RH-20FRH				RV-4FRL, RV-7FR, RV-7FRL				RV-13FR, RV-20FR				
Valve function	Double solenoid 5/2	Double solenoid 5/2				Double solenoid 5/2				Double solenoid 5/2				Double solenoid 5/2				
Operating method	Internal pilot method	Internal pilot method				Internal pilot method				Internal pilot method				Internal pilot method				
Effective sectional area (CV value)	0.64 mm	0.64 mm				0.64 mm				0.64 mm				0.64 mm				
Operating pressure range	1–7 bar	1–7 bar				1–7 bar				1–7 bar				1–7 bar				
Maximum pressure	10 bar	10 bar				10 bar				10 bar				10 bar				
Response time	<22 ms at 5 bar	<22 ms at 5 bar				<22 ms at 5 bar				<22 ms at 5 bar				<22 ms at 5 bar				
Max. operating frequency	5 Hz	5 Hz				5 Hz				5 Hz				5 Hz				
Ambient temperature	-10–50 °C	-10–50 °C				-10–50 °C				-10–50 °C				-10–50 °C				
Coil rated voltage	24 V DC ±10 %	24 V DC ±10 %				24 V DC ±10 %				24 V DC ±10 %				24 V DC ±10 %				
Order information	Art. no.	238375	250470	250471	250472	250473	153057	153058	153059	153062	255281	255282	255283	255284	268829	268830	268831	268832

Bellows



Bellows

By adding the bellows to the Z axis, the IP protection can be increased to IP65 for the horizontal articulated robots RH-1FRHR, RH-6FRH, RH-12FRH, and RH-20FRH.

Bellow type	Robot type	Z-Axis length	Art. no.
1F-JS-21	RH-1FRHR	150 mm	277714
1F-JS-01	RH-6FRH	200 mm	251456
1F-JS-02	RH-6FRH	340 mm	251457
1F-JS-05	RH-12FRH	350 mm	255689
1F-JS-06	RH-12FRH	450 mm	255690
1F-JS-09	RH-20FRH	350 mm	255693
1F-JS-10	RH-20FRH	450 mm	255694

Interface boards for robot controllers

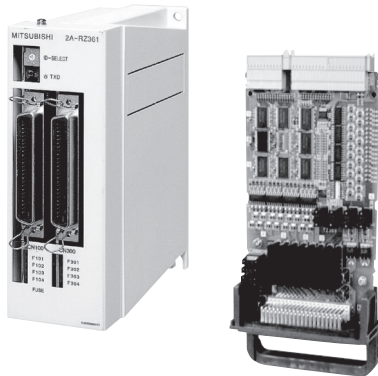

I/O interface

You can use 32 I/Os by adding the 2D-TZ378 interface module in one of the slots for your Optioncards.

By adding 2A-RZ371 slot-in cards you can increase the number of remote I/Os to 256 (depends on the controller model).

Specifications	2A-RZ371	2D-TZ378
Application	Interface for additional inputs/outputs	
Type	Decentralized I/O box with 32 inputs and 32 outputs	Slot-in card with 32 inputs and 32 outputs
Range of use	Only for D controller	
Rated load voltage	Inputs: 12 V/24 V; outputs: 12 V/24 V, max. 0.1 A/per output	
Max. no. of usable I/O boxes	7	2
Order information	Art. no. 124658	218862

For I/O connection cables see page 54.

Profinet I/O / EtherCAT / CC-Link IE Field / EtherNet/IP interface

These interface cards make it possible to integrate the robot controller in a Profinet I/O, in an EtherCAT, in

a CC-Link IE Field or in an Ethernet/IP network.



Specifications	2D-TZ535-PN-SET	2F-DQ535-ECT-SET	2F-DQ535-CCIEF-SET	2D-TZ535-EIP-SET
Application	Profinet I/O	EtherCAT	CC-Link IE Field	EtherNet/IP
Range of use	Only for D controller			
Communications cable	Industrial Ethernet twisted pair cable			
Transmission speed	100 Mbit/s		1 Gbit/s	100 Mbit/s
Number of I/O data	Max. 256 bytes send and max. 256 bytes receive			
Order information	Art. no. 269546	413963	324560	282409

CC-Link interface

The 2D-TZ576 interface makes it possible to integrate the CRm-D robot controller in a CC-Link network.

The CC-Link interface is a high-speed bit (for I/Os) and word (for data registers) network card.



Specifications	2D-TZ576
Application	CC-Link interface
Range of use	Only for D controller
Communications cable	Shielded 3-core twisted cable
Max. number of I/O points and data registers	126 I/Os/16 data register
Refresh rate	7.2 ms
Communications distances	100 m at 10 Mbps, 150 m at 5 Mbps, 250 m at 2.5 Mbps, 600 m at 0.62 Mbps, 1500 m at 0.15 Mbps
Order information	Art. no. 219063

Profibus interface

These interface cards make it possible to integrate the robot controller in a Profibus network.



Specifications	2D-TZ577
Application	Profibus DP interface
Range of use	Only for D controller
Communications cable	Twisted pair cable
Communications distances	1200 m at 9.6/19.2/93.75 Kbps, 1000 m at 187.5 Kbps, 400 m at 500 Kbps, 200 m at 1500 Kbps
Max. no. of communications words	122
Order information	Art. no. 218861

■ Gripper signal cables



Connection cables

A variety of different cables are available for connecting the control and status monitoring signals of the gripper tools.

When the pneumatic gripper is used you need to monitor the position of the gripper.

You should thus always connect a gripper signal input cable when you use the pneumatic gripper. One end of the cable set is fitted with a plug for the gripper's sensor signals. The other end is without connectors and can be wired as required for your system.

Hand output cable

Specifications	1E-GR35S	1F-GR35S-02	1F-GR60S-01	1S-GR35S-02	
Type	Hand signal output cable				Hand input-output cable
Range of use (robot type)	RV-2FR(B)/RV-2FRL(B)	RV-4FRL, RV-7FR/RV-7FRL/7FRL, RV-13FR/13FRL, RV-20FR	RH-1FRHR, RH-3FRH/RH-6FRH/RH-12FRH/RH-20FRH	RH-3FRHR	RV-12CRL
Design	Single sided with connector				
Application	Custom-made magnetic valve set				
Length mm	350	500	1050	450	1000
Order information Art. no.	47391	255285	250467	166272	713770

Hand input cable

Specifications	1F-HC35C-01	1F-HC35C-02	1F-HC35S-02	1S-HC00S-01	1S-HC30C-11
Type	Hand signal input cable				
Range of use (robot type)	RH-1FRHR, RH-3FRH, RH-6FRH	RH-12FRH/RH-20FRH	RV-4FRL, RV-7FR, RV-7FRL/7FRL, RV-13FR/13FRL, RV-20FR	RH-3FRHR	RV-2FR(B)/RV-2FRL(B)
Design	Single sided with connector				
Application	Monitoring of the gripper condition				
No. of cores	12		10	6	11
Length mm	1650	1800	1000	1210	300
Order information Art. no.	250474	254395	255286	238376	257063

■ Connectors

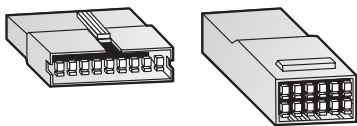

The connection to your system

Choose additional components to configure the optimal interface between the robot system and your application. The wide range of options makes it possible to configure the robot precisely for the individual requirements of your application.

The connectors listed in the following table can be used for making your own cables for the gripper input and output signals (see also the table above).

Specifications	RV-F / RV-FR Connector set	RH-FH / RH-FRH Connector set
Type	Connector set for OP1/2/3/4 & GR1/2 signals and LAN	Connector set for HC1/2 & GR1/2 signals
Range of use (robot type)	All MELFA RV-FR robots	All MELFA RH-FRH robots
Design	Complete set	
Shipping contents	Plug and contacts	
Order information Art. no.	268039	273182

Hand curl tube

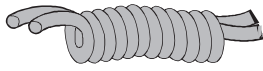

Replacement gripper hoses

These spiral hoses are for use with the pneumatic gripper. They are also suitable for use with cleanroom robots.

Specifications	1E-ST0404C	1E-ST0408C-300	1N-ST0608C-01	1S-ST0304S
Type	Spiral hose			
Range of use (robot type)	RV-2FR(B)/2FRL(B), RV-4FRL, RV-7FR/7FRL/7FRL	RH-1FRHR, RH-3FRH/6FRH	RH-12FRH/20FRH, RV-13FR/20FR	RH-3FRHR
Application	For double pneumatic gripper	For quadruple pneumatic gripper		For double pneumatic gripper
Dimensions mm	4xØ 4	8xØ 4	8xØ 6	4xØ 3
Order information Art. no.	47389	270236	269556	238377

Machine cables for robots and controllers



Replacement cables for power and signal connections

These machine cables make it possible to decrease/increase the distance between the controller and the robot arm. Versions are available for either flexible and fixed routing of the cables between the controller and the robot arm.

Use the flexible versions for installation of the cables in drag chains and similar configurations. These cables replace the standard cables supplied with the robot or need to be ordered when the robot systems are ordered without machine cable (-SN Version).

Fixed installation

Specifications	1F-02UCBL-41	1F-03UCBL-42	1F-05UCBL-41	1F-10UCBL-41/-42/-43	1F-15UCBL-41/-42/-43	1F-20UCBL-41/-42/-43
Type	Replacement cable for a fixed installation					
Range of use (robot type)	RV-2FR, RV-2FRL, RV-4FRL, RV-7FR/7FRL/7FRL, RV-13FR/13FRL, RV-20FR, RH-3FRH/6CRH	RH-3FRHR, RH-6FRH, RH-12FRH, RH-20FRH, RV5-AS	RRV-2FR, RV-2FRL, RV-4FRL, RV-7FR/7FRL/7FRL, RV-13FR/13FRL, RV-20FR, RH-3FRHR, RH-6FRH, RH-12FRH, RH-20FRH, RV5-AS	-41: RV-2FR, RV-2FRL, RV-4FRL, RV-7FR/7FRL/7FRL, RV-13FR/13FRL, RV-20FR, RH-3FRHR, RH-6FRH, RH-12FRH, RH-20FRH, RV5-AS	-42: RH-3CRH/6CRH	-43: RV-8CRL
Minimum bending radius	More than 150 mm					
Protection rating	Oil-proof specification sheath					
Length m	2	3	5	10	15	20
Order information Art. no.	325730	504046	410994	313106/504047/492800	313107/504048/492801	327863/504049/492892

Flexible installation

Specifications	1F-10LUCBL-41/-42/-43/-45	1F-15LUCBL-41/-42/-43/-45	1F-20LUCBL-41/-42/-43/-45
Type	Replacement cable for a flexible installation in a drag chain		
Range of use (robot type)	-41: RV-2FR, RV-2FRL, RV-4FRL, RV-7FR/7FRL/7FRL, RV-13FR/13FRL, RV-20FR, RH-3FRHR, RH-6FRH, RH-12FRH, RH-20FRH	-42: RH-3CRH/6CRH	-43: RV-8CRL
Minimum bending radius	More than 100 mm		
Cable bear isovolumetric ration	≤50 %		
Max. movement speed	2000 mm/s		
Guidance of life count	7.5 million times		
Protection rating	Oil-proof specification sheath		
Length m	10	15	20
Order information Art. no.	313108/504050/492893/732983	313109/504515/492894/732983	327864/504516/492895/732984

Connection cables, controller protection box, batteries

Connection cables for PCs and inputs/outputs



Connection cables, connectors

The MR-J3USBCBL3M cable is for establishing a USB connection between the robot controller and a personal computer.

The I/O connection cable is for connecting peripherals to the parallel I/O interface.

One end of the cable is fitted with a connector for the controller's parallel I/O port. The other end is supplied without a connector so that you can connect the appropriate connectors for your equipment.

Specifications	MR-J3USB-CBL3M	2A-CBL05	2A-CBL15	2D-CBL05	2D-CBL15	
Type	USB connection PC-controller	I/O cable for 2A-RZ371		I/O cable for 2D-TZ378		
Range of use	FR series	Only for D controller				
Design	Mini USB	Plug on one side				
Length	m	3	5	15	5	15
Order information	Art. no.	160229	47387	59947	218857	218858

Controller protection box (IP54)



The controller protection box for the control unit CR800 prevents the penetration of oil mist or other influences from the operating environment.

The front of the housing is equipped with a mode switch and a connector for the teaching box.

Specifications	CR800-MB
Type	Controller protection box
Application	Controller CR800
Dimensions (WxHxD)	mm 495x250x725
Order information	Art. no. 313062

Buffer batteries



Batteries

The backup batteries are used to maintain the encoder and memory power supply.

The number of batteries depends on the robot type. For the FR series, you can order the battery set directly.

Specifications	RH-FRH series	RV-FR series	Art. no.
MR-BAT6V1	Number 4		248692
Battery set RH-FRH/RV-FR	for RH-FRH series and RV-FR series consists of 4 pcs. MR-BAT6V1		327911

Options overview for all robots

Option	Marking	RV-2FR(B)/ RV-2FRL(B)	RV-4FRLM	RV-7FRM/ RV-7FRLM RV-7FRLLM	RV-13FRM/ RV-13FRLM/ RV-20FRM	RV-5AS	RV-8CRL	RH-12CRL	RH-3FRH	RH-6FRH	RH-12FRH/ RH-20FRH	RH-1FRHR	RH-3FRHR	RH-3CRH/ RH-6CRH/ RH-20CRH	RH-10CRH/ RH-20CRH	Art. no.	See Page
Teaching Box	R32TB			•	•	•	•	•	•	•	•	•	•	•	•	214968	60
Teaching Box	R86TB			•	•	•	•	•	•	•	•	•	•	•	•	687249	60
EMG-Output for TB_EMB	2F-TBSTS-01			•	•	•	•	•	•	•	•	•	•	•	•	279057	—
Force sensor	4F-FS002H-W200		•	•	•	•	•	•	•	•	•	•	•	•	•	313064	61
	4F-FS002H-W1000		•	•	•		•	•	•	•	•	•	•	•	•	313105	61
2-piece force sensor conversion cable set	1F-ASSISTA-ADCBL					•										504043	—
Vision sensor mounting bracket	1F-ASSISTA-2DVSFLG					•										504044	—
MELFA SafePlus	4F-SF002-01	•	•	•	•		•	•	•	•	•	•	•	•	•	313061	61
MELFA SafePlus II Slim	4F-SF003-05	•	•	•	•		•	•	•	•	•	•	•	•	•	603944	61
MELFA Smart Plus card pack	2F-DQ510	•	•	•	•		•	•	•	•	•	•	•	•	•	325728	65
	2F-DQ520	•	•	•	•		•	•	•	•	•	•	•	•	•	486379	65
MELFA Smart Plus card	2F-DQ511	•	•	•	•		•	•	•	•	•	•	•	•	•	325729	65
	2F-DQ521	•	•	•	•		•	•	•	•	•	•	•	•	•	486380	65
Quadruple valve set	1S-VD04E-05												•			238375	64
Single valve set	1E-VD01E	•														47397	64
Double valve set	1E-VD02E	•														47398	64
Single valve set	1F-VD01E-01					•	•	•	•			•				250470	64
Double valve set	1F-VD02E-01					•	•	•	•			•				250471	64
Triple valve set	1F-VD03E-01						•	•	•			•				250472	64
Quadruple valve set	1F-VD04E-01						•	•	•			•				250473	64
Single valve set	1F-VD01E-02		•	•												255281	64
Double valve set	1F-VD02E-02		•	•												255282	64
Triple valve set	1F-VD03E-02		•	•												255283	64
Quadruple valve set	1F-VD04E-02		•	•												255284	64
Single valve set	1F-VD01E-03				•											268829	64
Double valve set	1F-VD02E-03				•											268830	64
Quadruple valve set	1S-VD04E-01										•					153065	64
Single vacuum valve set	1F-W01E-01											•				277712	64
Double vacuum valve set	1F-W02E-01											•				277713	64
Bellows	1F-JS-21											•				277714	64
	1F-JS-01									•						251456	64
	1F-JS-02									•						251457	64
	1F-JS-05										•					255689	64
	1F-JS-06										•					255690	64
	1F-JS-09										•					255693	64
	1F-JS-10										•					255694	64
CC-Link interface ¹	2D-TZ576	•	•	•	•	•	•	•	•	•	•	•	•	•	•	219063	65
CC-Link IE Field interface ¹	2F-DQ535-COIEF-SET	•	•	•	•	•	•	•	•	•	•	•	•	•	•	324560	65
Profibus interface ¹	2D-TZ577	•	•	•	•	•	•	•	•	•	•	•	•	•	•	218861	65
EtherCat interface ¹	2F-DQ535-ECT-SET	•	•	•	•	•	•	•	•	•	•	•	•	•	•	413953	65
Profinet interface ¹	2D-TZ535-PN-SET	•	•	•	•	•	•	•	•	•	•	•	•	•	•	269546	65
Ethernet/IP interface ¹	2D-TZ535-EIP-SET	•	•	•	•	•	•	•	•	•	•	•	•	•	•	282409	65
I/O interface ¹	2D-TZ378	•	•	•	•	•	•	•	•	•	•	•	•	•	•	218865	65
	2A-RZ371	•	•	•	•		•	•	•	•	•	•	•	•	•	124658	65
Hand signal output cable	1E-GR35S	•														47391	66
	1F-GR35S-02		•	•	•											255285	66
	1F-GR60S-01							•	•	•	•	•				250467	66
	1S-GR35S-02												•			166572	66
Hand signal input cable	1F-HC35C-01							•	•	•		•				250474	66
	1F-HC35C-02										•					254395	66
	1F-HC35S-02		•	•	•											255286	66
	1S-HC00S-01												•			238376	66
	1S-HC30C-11	•														257063	66
Connector sets	RH-FRH Hand connector set							•	•	•	•	•	•			273182	66
	RV-F/RV-FR connector set		•	•	•											268039	66

Options overview for all robots

Option	Marking	RV-2FR(B)/ RV-2FRL(B)	RV-4FRLM	RV-7FRM/ RV-7FRLM RV-7FRLLM	RV-13FRM/ RV-13FRLM/ RV-20FRM	RV-5AS	RV-8CRL	RV-12CRL	RH-3FRH	RH-6FRH	RH-12FRH/ RH-20FRH	RH-1FRHR	RH-3FRHR	RH-3CRH/ RH-6CRH/	RH-10CRH/ RH-20CRH	Art. no.	See Page	
Hand curl tube	1E-ST0404C	•	•	•												47389	67	
	1E-ST0408C-300								•	•		•				270236	67	
	1S-ST0304S												•			238377	67	
	1N-ST0608C-01				•						•					269556	67	
Internal wiring and piping set	1F-HS304S-01							•	•			•				250468	63	
	1F-HS408S-01									•						250469	63	
	1F-HS604S-01										•					254396	63	
External wiring/piping box	1F-UT-BOX								•	•						251104	63	
	1F-UT-BOX-01										•					254398	63	
Forearm external wiring set	1F-HB01S-01		•	•	•											257936	63	
Base external wiring set	1F-HA01S-01		•	•	•											257935	63	
Replacement cable for fixed installation	1F-02UCBL-41	•	•	•	•	•			•	•	•	•	•			325730	58	
	1F-10UCBL-41	•	•	•	•	•			•	•	•	•	•			313106	67	
	1F-15UCBL-41	•	•	•	•	•			•	•	•	•	•			313107	67	
	1F-20UCBL-41	•	•	•	•	•			•	•	•	•	•			327863	67	
	1F-03UCBL-42													•		504046	67	
	1F-10UCBL-42													•		504047	67	
	1F-15UCBL-42													•		504048	67	
	1F-20UCBL-42													•		504049	67	
	1F-10UCBL-43						•	•								492800	67	
	1F-15UCBL-43						•	•								492801	67	
1F-20UCBL-43						•	•								492892	67		
Replacement cable for flexible installation in a drag chain	1F-10LUCBL-41	•	•	•	•				•	•	•	•	•			157582	67	
	1F-15LUCBL-41	•	•	•	•				•	•	•	•	•			313109	67	
	1F-20LUCBL-41	•	•	•	•				•	•	•	•	•			327864	67	
	1F-10LUCBL-42													•		504050	67	
	1F-15LUCBL-42													•		504515	67	
	1F-20LUCBL-42													•		504516	67	
	1F-10LUCBL-43						•	•								492893	67	
	1F-15LUCBL-43						•	•								492894	67	
	1F-20LUCBL-43						•	•								492895	67	
	1F-10LUCBL-45														•	732982	67	
1F-15LUCBL-45														•	732983	67		
1F-20LUCBL-45														•	432982	67		
PC connection cable USB	MR-J3USBCBL3M	•	•	•	•	•	•	•	•	•	•	•	•	•	•	160229	68	
Connection cable for I/O interface ¹	2A-CBL05	•	•	•	•	•	•	•	•	•	•	•	•	•	•	•	47387	68
	2A-CBL15	•	•	•	•	•	•	•	•	•	•	•	•	•	•	•	59947	68
	2D-CBL05	•	•	•	•	•	•	•	•	•	•	•	•	•	•	•	218857	68
	2D-CBL15	•	•	•	•	•	•	•	•	•	•	•	•	•	•	•	218858	68
Controller protection box (IP54)	CR800-MB	•	•	•	•	•	•	•	•	•	•	•	•	•	•	313062	68	
Wall mount	R32TB wall mount	•	•	•	•	•	•	•	•	•	•	•	•	•	•	274317	60	
Wall bracket	R86TB wall bracket	•	•	•	•	•	•	•	•	•	•	•	•	•	•	696465	60	

■ MELFA-BASIC programming

Easy-to-Learn MELFA-BASIC Programming language

Mitsubishi Electric robots are controlled with programs written in the powerful MELFA BASIC programming language. In addition to the familiar standard BASIC instructions and constructs like FOR ... NEXT and GOTO, MELFA BASIC also has some extensions required for robots, including additional data types, instructions for movement and gripper control and I/O instructions. The familiarity of standard BASIC makes it easy for beginners to get started with robot

programming. Despite its simplicity and short learning curve, MELFA BASIC is a powerful language that can be used to create very complex robot programs MELFA BASIC VI allows structured programming with functions and re-use code and ready-made libraries are additionally improving the reusability and readability.

Programming

Robot programs are written with the MELFA BASIC instructions with the

help of a PC and the teaching box. The positions are defined with the teaching box and the actual program is written on the PC.

Programs are written using the RT Toolbox3 programming and project managing software for industrial robots. You can find more information about the programming software on the following pages.

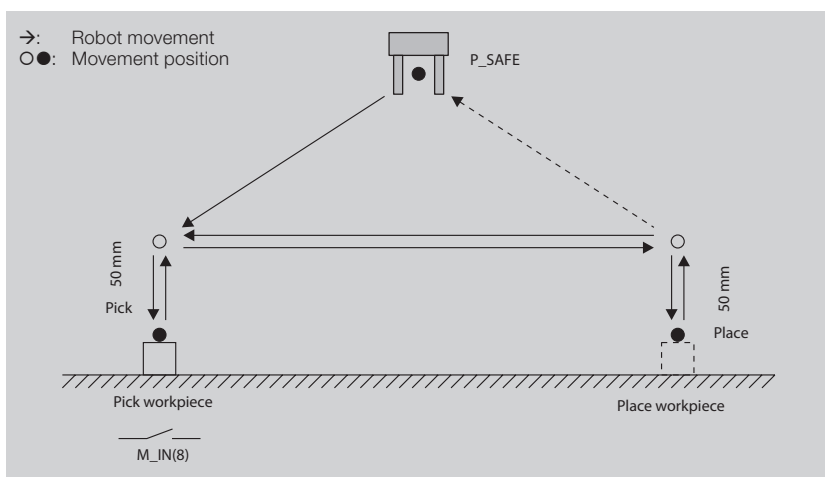

Sample program

The sample program below is for a pick-and-place operation. The input signal M_IN(8) tells the program that there is a workpiece in position Pick. When a work-piece is present the input signal is set to 1 and the pick-and-place operation is performed. The workpiece is picked up from position Pick and deposited in position Place. If no workpiece is present the robot remains in the retracted position P_SAFE.

Pick-and-Place Program

1	MVS P_SAFE	Move to safe position
2	Wait M_IN(8) = 1	Wait until input bit 8 is set
3	HOPEN 1	Open gripper 1
4	*PickPlace	Jump-Destination "PickPlace"
5	MVS Pick, -50	Move longitudinally to a position 50 mm from "Pick" relative to the tool Z-direction
6	MVS Pick	Move to position "Pick"
7	HCLOSE 1	Close gripper 1
8	DLY 0.2	Wait for 0.2 s to ensure proper closing of gripper
9	MVS Pick, -50	Move longitudinally to a position 50 mm from "Pick" relative to the tool Z-direction
10	MVS Place, -50	Move longitudinally to a position 50 mm from "Place" relative to the tool Z-direction
11	MVS Place	Move to position "Place"
12	HOPEN 1	Open gripper 1 and deposit workpiece
13	DLY 0.2	Wait for 0.2 s to ensure proper opening of gripper
14	MVS Place, -50	Move longitudinally to a position 50 mm from "Place" relative to the tool Z-direction
15	IF M_IN(8) = 1 THEN GOTO *PickPlace	If another workpiece is present repeat the pick-and-place operation
16	MVS P_SAFE	If no workpiece is present return to safe position and end program
17	END	Program end

■ **RT ToolBox3**

RT ToolBox3 is a software for program creation and total engineering support. This PC software supports everything from system startup to debugging, simulation, maintenance and operation. This includes programming and editing, operational checking before robots

are installed, measuring process tact time, debugging during robot startup, monitoring robot operation after startup, and troubleshooting.

- Compatible with Windows® 10 and Windows® 11.
- Support of all MELFA robots

- Support for all processes, from programming and startup to maintenance
- Enhanced simulation functions
- Advanced maintenance functions
- Extended documentation function

Enhanced RT ToolBox3 visual functions

- Set parameters can be displayed visually to prevent setting errors.
- Display of teaching positions and trajectories of end-points.
- Hands can be created and then attached to the robot.
- 3D polygonal models can be imported into the program. (Applicable 3D data file formats: STL, OBJ)

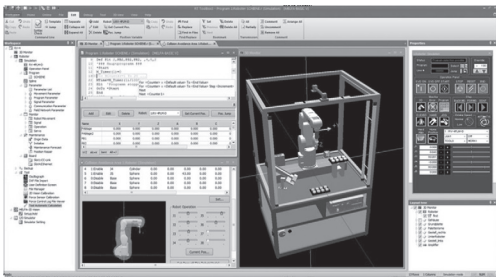

Linked to iQ Works2

- Integrated Software Suite Consists of GX Works3, MT Works2, GT Works3, RT ToolBox3 and FR Configurator2, which are programming software for each respective product
- System management software MELSOFT Navigator is the central system configuration incorporating an easy-to-use, graphical user interface with additional project-sharing features such as system labels and parameters.

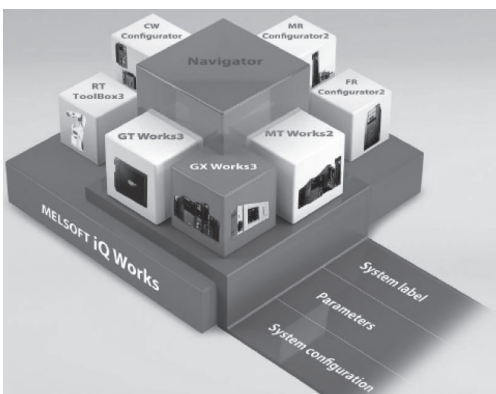

Program editing and debugging functions

Creation of programs in MELFA-BASIC IV/V/VI languages.* Improvement of work operations by a multi-window format and the various editing functions. This is helpful for use in checking operations such as the execution of program steps, setting of breakpoint settings, and other tasks.

* MELFA-BASIC is a programming language that further expands upon and develops the commands needed for robot control. In MELFA-BASIC, the expansion of the command as well as parallel processing or structuring that were difficult to realize in BASIC language can make it possible to operate MELFA easily.

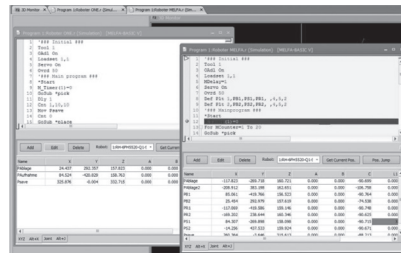

Simulation functions

Offline robot motion and tact time check for designated parts of a program.

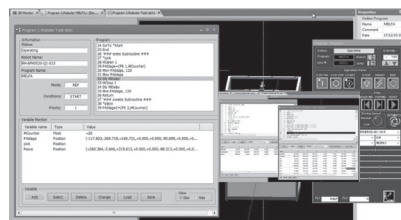

3D viewer

Graphical representation of a work along with the dimensions, color and other specified details of the work area to be gripped.

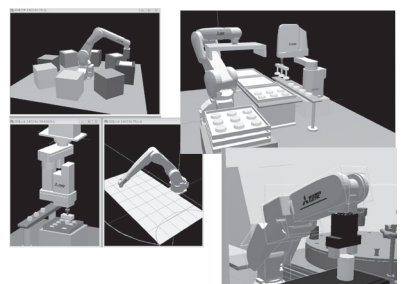

Monitor functions

This is used to monitor program execution status and variables, input signals, etc.)

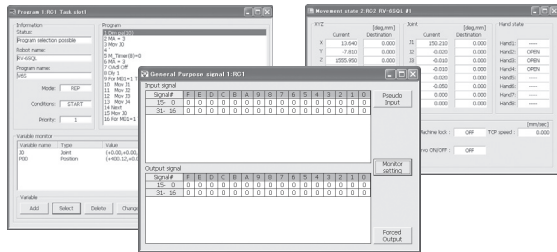

Maintenance functions

These functions include maintenance forecast, position recovery support, parameter management, etc.

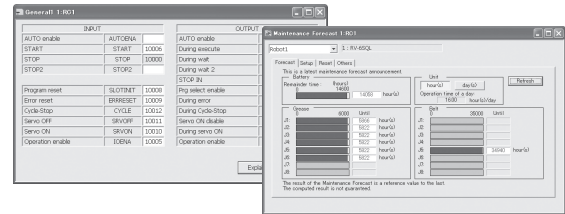

RT ToolBox3 Pro

A 3D robot simulator offers powerful support for system design and preliminary layout.

RT ToolBox3 Pro offers an add-in tool¹ for SolidWorks² used for robot simulation in production systems on PC's converting processing paths of workpieces into robot position data. Adding RT ToolBox3 Pro into the SolidWorks platform adds to and expands on the robot simulation functions.

- Loading of part data from peripheral created in SolidWorks® devices and rearrangement
- Installation of hands by CAD files
- Handling of workpieces
- Creating operation data from 3D CAD source data

- Offline teaching in 3D CAD surrounding
- Creation of robot programs (template) Workflow processes can be created using a combination of the offline teaching and CAD link functions and then converted into robot programs. (MELFA-BASIC IV, V, VI format)
- Simulation of robot operations
- Display of the robot movement path in the application/the workspace
- Interference checks between the robot and peripheral devices
- Saving simulated movements to video files (AVI format)
- Measurement of cycle times

- Robot program debugging functions
- Jog function – teaching the robot
- Installation of a traveling axis to verify the operation of the system equipped with this.
- Calibration of point sequence data of CAD coordinates and robot coordinate data

¹ An add-in tool is a software program that adds certain functions to application software packages.
² SolidWorks® is a registered trademark of SolidWorks Corp., (USA).

Automatic robot program creation function

The teaching position data and robot operation programs necessary for operating robots can be generated automatically by simple loading of 3D CAD data³ for the applicable works into SolidWorks® and then setting of processing conditions and areas using RT ToolBox3 Pro.

³ Formats that can be loaded into SolidWorks®

<ul style="list-style-type: none"> • IGES • STEP • ParasolidR • SAT (ACISR) • Pro/ENGINEER • CGR (CATIARgraphics) • Unigraphics • PAR (Solid Edge TM) 	<ul style="list-style-type: none"> • IPT (Autodesk Inventor) • DWG • DXFTM • STL • VRML • VDA-FS • Mechanical Desktop 	<ul style="list-style-type: none"> • CADKEYR • Viewpoint • RealityWave • HOOPS • HCG (Highly compressed graphics)
---	--	--

Note: Check the SolidWorks website and other published documents for the latest specifications.

Example screens for RT ToolBox3 Pro

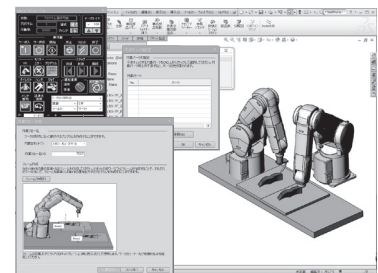

RT VisualBox

ASSISTA and the camera capture the target using the “RT VisualBox” auto-focus function.

“RT VisualBox” proprietary engineering tool

The RT VisualBox programming tool developed by Mitsubishi Electric is a visual programming software for MELFA ASSISTA. Intuitive flowchart programming makes it easy to create programs by simply drag-and-drop blocks, requiring only the parameters for the functions to be set. No robot programming knowledge is needed to get MELFA ASSISTA working. You can simulate the operation of the Cobot without hardware being installed. A set-up wizard provides operators with an easier more intuitive methodology for peripheral configurations.

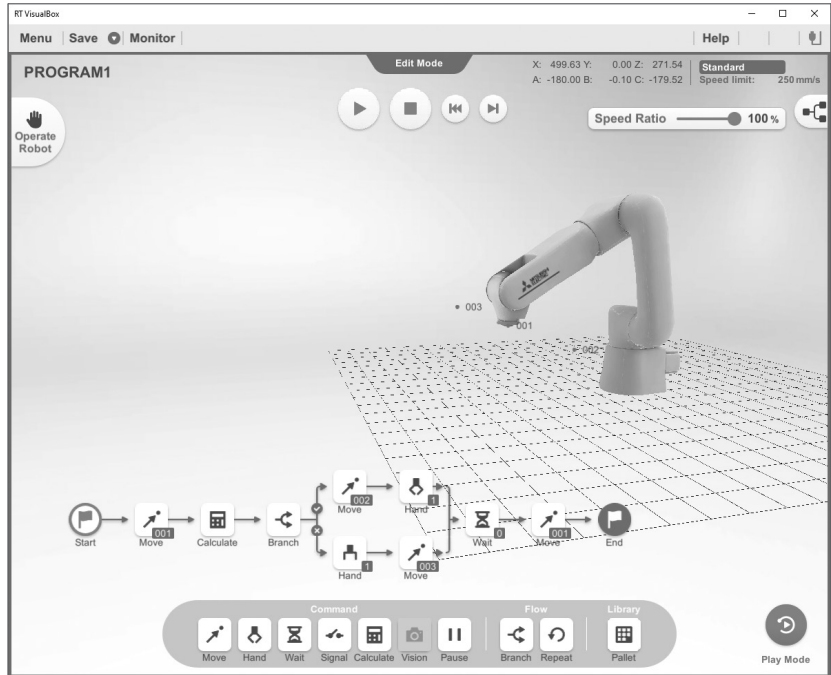

Example screens for RT VisualBox

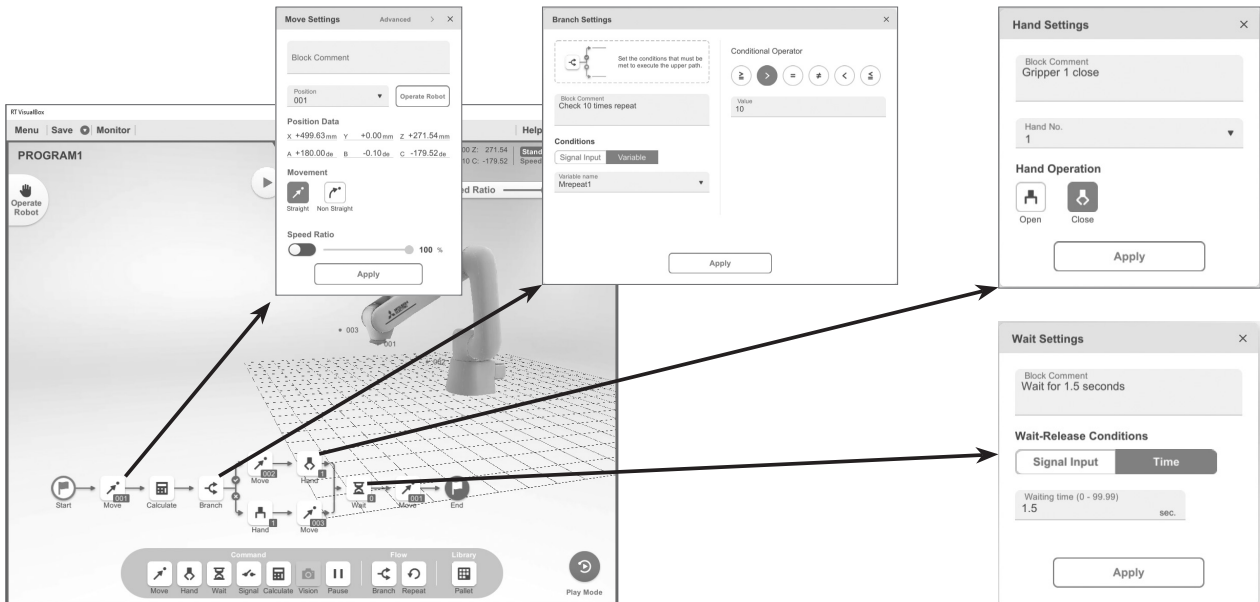

A

Accessories

Batteries	68
Bellows	64
Connection cables for PCs and inputs/outputs, connectors	68
Connectors	66
Controller protection box	68
Force sensor	61
Gripper signal cables	66
Hand curl tube	67
Interface boards	65
Machine cables for robots and controllers	67
MELFA SafePlus	61
MELFA Smart Plus Card and MELFA Smart Plus card pack	62
Solenoid valve sets	64
Teaching box	60
Wiring	63

C

Collaborative robots

RV-5AS-D	42
----------	----

Controller 57

D

Dimensions

Controller	57
RH-1FRHR	46
RH-3FRHR	48
RH-CRH	53
RH-FRH	50
RV-2FR(L)(B)	32
RV-4FRLM	34
RV-5AS-D	42
RV-7FRM/7FRLM/7FRLLM	36
RV-8CRL	44
RV-13FRM/RV-13FRLM/RV-20FRM	38
RV-35F/RV-50F/RV-70F	40

M

Movement ranges

RH-1FRHR	46
RH-3FRHR	48
RH-CRH	53
RH-FRH	50
RV-2FR(L)(B)	32

RV-4FRLM	34
RV-5AS-D	42
RV-7FRM/7FRLM/7FRLLM	36
RV-8CRL	44
RV-13FRM/RV-13FRLM/RV-20FRM	38
RV-35F/RV-50F/RV-70F	40

O

Options overview for all robots . . 69

Overview robots

Horizontal articulated robots (RH)	16
Mitsubishi Electric collaborative robot "ASSISTA"	18
Model designation	19, 20
Vertical articulated robots (RV)	29

P

Programming language

MELFA-BASIC programming	71
-------------------------	----

S

SCARA robots

RH-1FRHR	46
RH-3FRHR	48
RH-CRH	53
RH-FRH	50

Software

RT ToolBox3	72
RT ToolBox3 Pro	73
RT VisualBox	74

Standard high end functions

Adaptation to operation	24
CC-Link IE Field Network Basic function	26
Collision avoidance	26
Connection to peripheral devices	25
Coordinated control	26
Full use of installation space	22
GOT terminals	31
High accuracy	24
Intelligent technology	27
iQ Platform	31
MELFA SafePlus features	30
Predictive maintenance function	28
Shortened takt times	22
Tooling performance	22
User friendliness	23

System configuration 56

V

Vertical articulated arm robots

RV-2FR(B)/RV-2FRL(B)	32
RV-4FRLM	34
RV-7FRM/7FRLM/7FRLLM	36
RV-8CRL	44
RV-13FRM/RV-13FRLM/RV-20FRM	38
RV-35F/RV-50F/RV-70F	40

Creating Solutions Together.



Low-voltage Power Distribution Products



Transformers, Med-voltage Distribution Products



Power Monitoring and Energy Saving Products



Power (UPS) and Environmental Products



Compact and Modular Controllers



Servos, Motors and Inverters



Visualization: HMIs



Edge Computing Products



Numerical Control (NC)



Collaborative and Industrial Robots

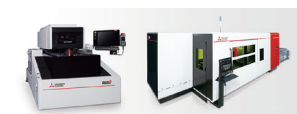

Processing machines: EDM, Lasers



SCADA, analytics and simulation software

Mitsubishi Electric's product lineup, from various controllers and drives to energy-saving devices and processing machines, all help you to automate your world. They are underpinned by software, innovative data monitoring, and modelling systems supported by advanced industrial networking and Edgecross IT/OT connectivity. Together with a worldwide partner ecosystem, Mitsubishi Electric factory automation (FA) has everything to make IoT and Digital Manufacturing a reality.

With a complete portfolio and comprehensive capabilities that combine synergies with diverse business units, Mitsubishi Electric provides a one-stop approach to how companies can tackle the shift to clean energy and energy conservation, carbon neutrality and sustainability, which are now a universal requirement of factories, buildings, and social infrastructure.

We at Mitsubishi Electric FA are your solution partners waiting to work with you as you take a step toward the realization of sustainable manufacturing and society through the application of automation. Let's automate the world together!

European Offices

Germany Mitsubishi Electric Europe B.V. Mitsubishi-Electric-Platz 1 D-40882 Ratingen Phone: +49 (0)2102 / 486-2048	Czech Republic Mitsubishi Electric Europe B.V. Pekařská 621/7 CZ-155 00 Praha 5 Phone: +420 734 402 587	France Mitsubishi Electric Europe B.V. 2, rue de l'Union F-92565 Rueil Malmaison cedex Phone: +33 1 41 02 83 00	Greece Mitsubishi Electric Europe B.V. 3 Konitsis street & 90 Kiffisias Ave Maroussi 15125, Greece Phone: +30 2106140050	Hungary Mitsubishi Electric Europe B.V. Budaörs Office Park, Building A, 3rd Floor, Szabadság street 117 HU-2040 Budapest Phone: +36 70 3322 372
Ireland Mitsubishi Electric Europe B.V. Westgate Business Park, Ballymount IRL-Dublin 24 Phone: +353 (0)1 4198800	Italy Mitsubishi Electric Europe B.V. Campus Energy Park Via Energy Park 14 - 20871 Vimercate (MB) Phone: +39 039 / 60 53 1	Netherlands Mitsubishi Electric Europe B.V. Capronilaan 34 NL-1119 NS Schiphol-Rijk Phone: +31 (0) 297 250 350	Poland Mitsubishi Electric Europe B.V. ul. Krakowska 48 PL-32-083 Balice Phone: +48 (0) 12 347 65 00	Romania Mitsubishi Electric Europe B.V. 22, Tudor Vladimirescu Street, Floor 6, Office 4.2, District 5 – Bucharest Phone: +40 31 229 0840
Slovakia Mitsubishi Electric Europe B.V. Levická 7 SK-949 01 Nitra Phone: +421 917 624036	Spain Mitsubishi Electric Europe B.V. Carretera de Rubí 76-80 Apdo. 420 E-08190 Sant Cugat del Vallés (Barcelona) Phone: +34 (0) 93 / 5653131	Sweden Mitsubishi Electric Europe B.V. (Scandinavia) Hedvig Möllers gata 6 SE-223 55 Lund Phone: +46 (0) 8 625 10 00	Turkey Mitsubishi Electric Turkey Elektrik Ürünleri A.Ş. Serifali Mahallesi Kale Sokak No:41 TR-34775 Ümraniye-İSTANBUL Phone: +90 (216) 969 25 00	UK Mitsubishi Electric Europe B.V. Travellers Lane UK-Hatfield, Herts. AL10 8XB Phone: +44 (0)1707 / 28 87 80

Representatives

Algeria MEC Casa ALGERIA Cité Algazel n.1 02000 Chlef – Algérie Phone: 021 327 798 069	Austria GEVA Wiener Straße 89 A-2500 Baden Phone: +43 (0)2252 / 85 55 20	Bosnia and Herzegovina AM Pneumatik d.o.o. Krcanska 15A/PP-1, SI-75000 Tuzla Phone: +387 35 364 430 Mobile: +387 61 101 582	Bosnia and Herzegovina INEA RBT d.o.o. Stegne 11 SI-1000 Ljubljana Phone: +386 (0)1/ 513 8116	Bulgaria AKHNATON 4, Andrei Ljapchev Blvd., PO Box 21, BG-1756 Sofia Phone: +359 (0)2/817 6000 Phone: +359 88 800 0061
Bulgaria PM Electrical Ltd. ulitsa Poruchik Nedelcho Bonchev 10, BG-1528 Sofia Phone: +359 87 827 6715	Croatia INEA CR Losinjska 4 a HR-10000 Zagreb Phone: +385 (0)1 / 36 940 - 01/ -02/-03	Czech Republic SIMAP CZ s.r.o. Nové sady 988/2 CZ-602 00 Brno Phone: +420 777 731 900	Denmark HANS FØLSGAARD A/S Theilgaard Torv 1 DK-4600 Køge Phone: +45 4320 8600	Egypt TECHNYON FOR SMART SOLUTION 36 Sherif Basha Str, 1st floor, Flat 1, Abdeen, 11613 -Cairo, Egypt K.A. Mr. Hossam Sakr Mob: +20 122 23 17 541
Estonia Electrobit OÜ Suur-Sõjamäe 13a 11415, Tallinn Phone: +372 6518 140	Finland UTU Automation Oy Peltotie 37 FIN-28400 Ulvila Phone: +358 (0)207 / 463 500	Greece UTECO A.B.E.E. 5, Mavrogenou Str. GR-18542 Piraeus Phone: +30 (0)211 / 1206-900	Hungary MELTRADE Kft. Fertő utca 14. HU-1107 Budapest Phone: +36 (0)1 / 431-9726	Israel ILAN & GAVISH Ltd. 24 Shenkar St., Kiryat Arie IL-49001 Petah-Tikva Phone: +972 (0)3 / 922 18 24
Israel SHERF MOTION TECHNOLOGIES LTD Haprat Street 2, Entrance A 2 floor 8122702 Yavne-Israel	Latvia SIA OAK Integrator Products Mežkalna iela 5, Rīga LV-1058	Lithuania Automatikos centras Pramonės pr. 17H, 51327 Kaunas, Lithuania tel:+37037262707	Macedonia RADE KONCAR-TEP 3rd Macedonian Brigade Blvd, MK-1000 Skopje Phone: +389 2 2402 481	Malta ALFATRADE Ltd. 99, Paola Hill Malta-Paola PLA 1702 Phone: +356 (0)21 / 697 816
Morocco SCHIELE MAROC SA Nouvelle Route Rabat KM 7.2 20600 Ain Sebaa Casablanca	Norway MITSUBISHI ELECTRIC EUROPE B.V. (SCANDINAVIA) Factory Automation Dronninggata 15, 3019 Drammen Phone: +47 915 02 650	Poland Enel – Dystrybucja Sp. z o.o. Józefa Sowińskiego 3, 44-101 Gliwice Phone: +(48) 32 237 61 80	Poland MECON Sp. z o.o. Xenon Business Park Śląska 53, 81-304 Gdynia Phone: +48 58 620 85 40 Mobile: +48 609 394 959	Poland PG SYSTEMS Sp. z o.o. Macieja Rataja 12, 05-070 Sulejówek Phone: +48 (22) 499 57 26 Mobile: +48 501 380 073
Portugal Fonseca S.A. R. João Francisco do Casal 87/89 PT-3801-997 Aveiro, Esgueira Phone: +351 (0)234 / 303 900	Romania Sirius Trading & Services SRL Aleea Lacul Morii Nr. 3 RO-060841 Bucuresti, Sector 6 Phone: +40 (0)21 / 430 40 06	Serbia INEA SR d.o.o. Batajnički drum 10, deo 1b 11080 Zemun, Beograd Republika Srbija info@inea.rs	Serbia Venting d.o.o. Beblerjev trg 3, RS-1000 Ljubljana Phone: +386 (059) 017 465 Mobile: +386 (0)51 415 116	Serbia VitaELKO d.o.o. Vojvodanska 165, RS-22304 Novi Banovci Phone: +381 22/343-197; +381 22/343-198 Phone: +381 22/341-452; +381 22/342-790;
Slovakia SIMAP SK Dolné Pažite 603/97 SK-911 06 Trenčín Phone: +421 (0)32 743 04 72	Slovenia INEA RBT d.o.o. Stegne 11 SI-1000 Ljubljana Phone: +386 (0)1 / 513 8116	South Africa ADROIT TECHNOLOGIES Four Ways 20 Waterford Office Park 189 Witkoppen Road Gauteng 2001 ZA Phone: + 27 (0)11/658 8100	South Africa MEGADRIVE AUTOMATION CC Mega Park, 26 Fourie Street Brackenfell, Cape Town 7560 ZA	Switzerland Robotronic AG Schlachthofstrasse 8 CH-8406 Winterthur Telefon: +41 (0)52/267 02 00
Tunisia MOTRA ELECTRIC 3, Residence Imen Avenue Des Martyrs El Mourouj III 2074	Ukraine CSC- AUTOMATION Ltd. 4 B, Yevhena Sverstyuka Str. UA-02002 Kiev Phone: +380 (0)44 / 494 33 44			



Mitsubishi Electric's e-F@ctory concept utilizes both FA and IT technologies, to reduce the total cost of development, production and maintenance, with the aim of achieving manufacturing that is a „step ahead of the times“. It is supported by the e-F@ctory Alliance Partners covering software, devices, and system integration, creating the optimal e-F@ctory architecture to meet the end users needs and investment plans.



Version check:



Mitsubishi Electric Europe B.V.

Factory Automation EMEA, Mitsubishi-Electric-Platz 1, D-40882 Ratingen Germany