



**mitsubishi
electric**

QA65B/QA68B Extension Base Unit

User's Manual

Thank you for purchasing the Mitsubishi Electric programmable controller MELSEC-Q series.

Prior to use, please read this and relevant manuals thoroughly to fully understand the product.

Programmable
Controller

MELSEC-Q

MODEL	QA65B-U
MODEL CODE	13JT32
IB(NA)-0800157-F(1612)MEE	

● CONDITIONS OF USE FOR THE PRODUCT ●

- (1) Mitsubishi programmable controller ("the PRODUCT") shall be used in conditions;
- i) where any problem, fault or failure occurring in the PRODUCT, if any, shall not lead to any major or serious accident; and
 - ii) where the backup and fail-safe function are systematically or automatically provided outside of the PRODUCT for the case of any problem, fault or failure occurring in the PRODUCT.
- (2) The PRODUCT has been designed and manufactured for the purpose of being used in general industries.

MITSUBISHI SHALL HAVE NO RESPONSIBILITY OR LIABILITY (INCLUDING, BUT NOT LIMITED TO ANY AND ALL RESPONSIBILITY OR LIABILITY BASED ON CONTRACT, WARRANTY, TORT, PRODUCT LIABILITY) FOR ANY INJURY OR DEATH TO PERSONS OR LOSS OR DAMAGE TO PROPERTY CAUSED BY the PRODUCT THAT ARE OPERATED OR USED IN APPLICATION NOT INTENDED OR EXCLUDED BY INSTRUCTIONS, PRECAUTIONS, OR WARNING CONTAINED IN MITSUBISHI'S USER, INSTRUCTION AND/OR SAFETY MANUALS, TECHNICAL BULLETINS AND GUIDELINES FOR the PRODUCT.

("Prohibited Application")

Prohibited Applications include, but not limited to, the use of the PRODUCT in;

- Nuclear Power Plants and any other power plants operated by Power companies, and/or any other cases in which the public could be affected if any problem or fault occurs in the PRODUCT.
- Railway companies or Public service purposes, and/or any other cases in which establishment of a special quality assurance system is required by the Purchaser or End User.
- Aircraft or Aerospace, Medical applications, Train equipment, transport equipment such as Elevator and Escalator, Incineration and Fuel devices, Vehicles, Manned transportation, Equipment for Recreation and Amusement, and Safety devices, handling of Nuclear or Hazardous Materials or Chemicals, Mining and Drilling, and/or other applications where there is a significant risk of injury to the public or property.

Notwithstanding the above, restrictions Mitsubishi may in its sole discretion, authorize use of the PRODUCT in one or more of the Prohibited Applications, provided that the usage of the PRODUCT is limited only for the specific applications agreed to by Mitsubishi and provided further that no special quality assurance or fail-safe, redundant or other safety features which exceed the general specifications of the PRODUCTS are required. For details, please contact the Mitsubishi representative in your region.

REVISIONS

*The manual number is given on the bottom right of the cover.

Print date	*Manual number	Revision
September 2015	IB(NA)-0800157-E	The Japanese manual (IB-0800157) with the English manual (IB-0800158) are combined.
December 2016	IB(NA)-0800157-F	Descriptions are revised due to compliance with the new China RoHS.

This manual confers no industrial property rights or any rights of any other kind, nor does it confer any patent licenses. Mitsubishi Electric Corporation cannot be held responsible for any problems involving industrial property rights which may occur as a result of using the contents noted in this manual.

© 2000 MITSUBISHI ELECTRIC CORPORATION

CONTENTS

1. OVERVIEW	1
1.1 Overview	1
1.2 Included Parts	1
2. SYSTEM CONFIGURATION	2
2.1 System Configuration.....	2
2.2 List of configuration devices.....	3
3. SPECIFICATIONS.....	5
4. PART NAMES AND SETTING	6
4.1 Part Names	6
4.2 Extension Stage Number Setting	7
5. MOUNTING AND INSTALLATION.....	8
5.1 Module Installation	8
5.2 Precautions for installing base unit	9
5.3 Installation and removal of modules.....	12
6. EXTERNAL DIMENSIONS	14

1. OVERVIEW

1.1 Overview

This User's Manual describes the specifications, configuration devices, names and settings of each part, and mounting and installation of the QA65B extension base unit, QA68B extension base unit (hereinafter, QA6□B).

Refer to the QCPU User's Manual(Hardware Design, Maintenance and Inspection) SH-080483ENG enclosed with the main base unit for the matters not described in this manual, such as the QA6□B safety precautions and general specifications.

1.2 Included Parts

This section describes parts included with this product.

Item	Type	Quantity
Extension base unit	QA6□B	1
I/O number seal	—	1
This manual	—	1

2. SYSTEM CONFIGURATION

2.1 System Configuration

The system configuration and precautions for using the QA6□B extension base unit are described in this section.

(1) Extension base unit connection order

When using the Q5□B/Q6□B, QA1S6□B and QA6□B together, connect from the unit closest to the main base unit in the order of Q5□B/Q6□B, QA1S6□B and QA6□B.

(2) Setting order of the extension stage numbers for extension base units

Extension base units require the setting of the extension stage numbers (1 to 7) using the stage setting connector.

Assign the extension stage numbers starting from 1 to 7 to the extension base units counting from the one which is connected to the main base unit.

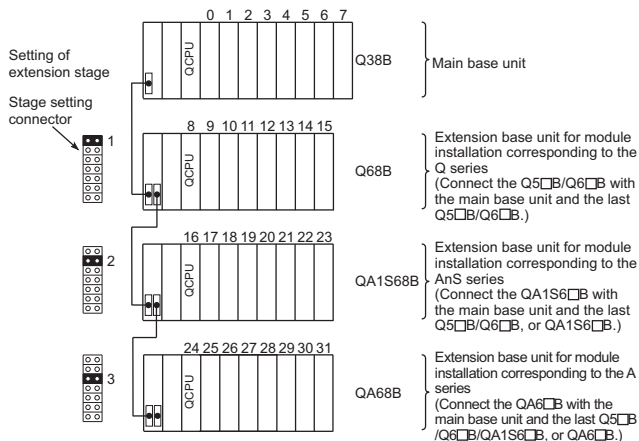

2.2 List of configuration devices

The following table lists the mountable modules on the QA6□B extension base unit.

Module	Type	Remarks
Power module	A61P, A61PN, A62P, A63P, A68P, A61PEU, A62PEU	—
Input module	AX10, AX11, AX11EU, AX20, AX21, AX21EU, AX31, AX31-S1, AX40, AX41, AX41-S1, AX42, AX42-S1, AX50-S1, AX60-S1, AX70, AX71, AX80, AX80E, AX81, AX81-S1, AX81-S2, AX81-S3, AX81B, AX82	—
Output module	AY10, AY10A, AY11, AY11A, AY11E, AY11AEU, AY11EEU, AY13, AY13E, AY13EU, AY15EU, AY22, AY23, AY40, AY40A, AY41, AY42, AY42-S1, AY42-S2, AY42-S3, AY42-S4, AY50, AY51, AY51-S1, AY60, AY60S, AY60E, AY70, AY71, AY72, AY80, AY81, AY82EP	—
I/O module	A42XY, AH42	—
High-speed counter module	AD61, AD61S1	*1
Analog-digital conversion module	A68AD, A68AD-S2, A68ADN, A616AD	—
Digital-analog conversion module	A62DA, A62DA-S1, A68DAV, A68DAI-S1, A616DAV, A616DAI	—
Temperature-digital conversion module	A68RD3, A68RD3N, A68RD4, A68RD4N, A616TD, A60MX, A60MXR, A60MXRN, A60MXT, A60MXTN	—
Interrupt module	AI61, AI61-S1	*2
Positioning module	AD70, AD70D, AD71, AD71S1, AD71S2, AD71S7, AD72	—
	AD75P1-S3, AD75P2-S3, AD75P3-S3, AD75M1, AD75M2, AD75M3	*1
MELSECNET/MINI-S3 master module	AJ71PT32-S3, AJ71T32-S3	*1
Intelligent communication module	AD51, AD51E, AD51H, AD51-S3, AD51E-S3, AD51H-S3	*2
PC fault detection module	AS91	—
MELSEC-I/OLINK module	AJ51T64	—
B/NET module	AJ71B62-S3	—
Blanking module	AG60	—
Dummy module	AG62	—
A-A1S conversion adapter	A1ADP-XY, A1ADP-SP	*3

- *1 The dedicated commands used in the QnA and A Series program cannot be used with the Q mode CPU.
Replace these with FROM/TO commands.
- *2 There is a limit to the number of mountable modules.

Module	Type	number of mountable
Intelligent communication module	AD51, AD51E, AD51-S3, AD51E-S3, AD51H, AD51H-S3	6 *4
Interrupt module	AI61, AI61-S1	1 *5

- *3 The AnS series modules (equivalent ones to the modules listed in the table) also can be used by using the A-A1S conversion adapter.
(Example: A68AD → A1S68AD)
For precautions on the module replacement, refer to the manual for the A-A1S conversion adapter.
- *4 In combined use of the QA1S6□B and QA6□B, up to 6 intelligent communication modules can be installed.
- *5 Only one interrupt module is valid which can be chosen from QI60, A1SI61, AI61 or AI61-S1.

3. SPECIFICATIONS

The QA6□B performance specifications are given below.

Item	Type	
	QA65B	QA68B
Number of I/O modules connected	5	8
Applicable modules	A series module	
5VDC internal current consumption	0.12A	
Weight	1.60kg	2.00kg

4. PART NAMES AND SETTING

The names of and settings for each QA6□B part are explained in this section.

4.1 Part Names

The names of each QA6□B part are explained below.

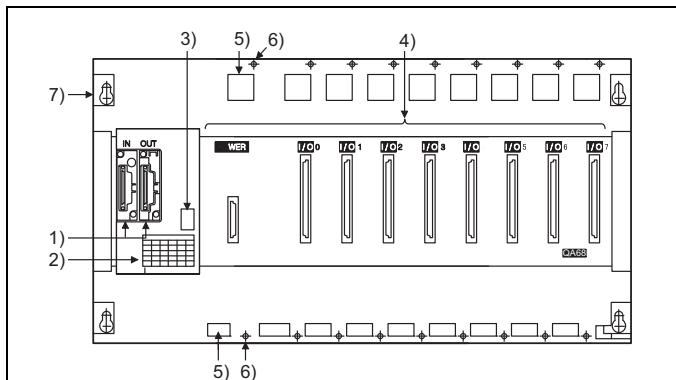

No.	Name	Application
1)	Extension cable connector	Connector for connecting an extension cable (for signal communications with the main base unit or other extension base unit)
2)	Base cover	Protective cover of extension cable connector. Before connecting an extension cable, the part under OUT on the base cover must be removed with a tool such as a flat blade screwdriver.
3)	Stage number setting connector	A connector used to set the stage numbers of the extension base units. Refer to Section 4.2 for the setting procedure.
4)	Module connector	Connectors for installing the power supply module, I/O modules, and special function modules. To those connectors located in the spare space where these modules are not installed, apply the supplied connector cover or blank cover module (AG60) / dummy module (AG62) to prevent entry of dirt.
5)	Module fixing hole	Cut out to accept projection and hook at rear of modules.
6)	Module fixing screw hole	Screw hole for fixing the module to the base unit. (M4 screw)
7)	Base unit installation hole	Hole for mounting this base unit on the panel such as a control panel. (M5 screw)

4.2 Extension Stage Number Setting

The method of setting the QA6□B stages is explained below.

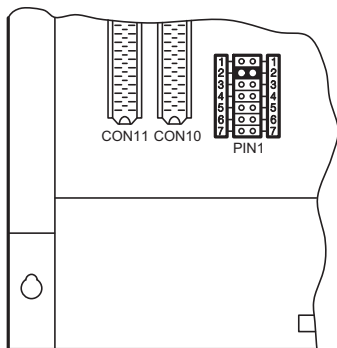
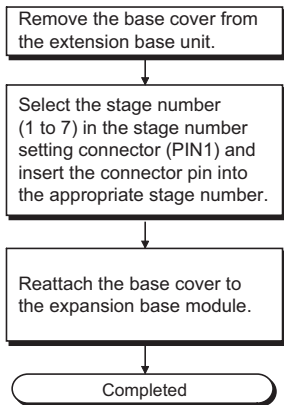

Stage number setting for extension base unit

	Extension stage number setting						
	1 st stage	2 nd stage	3 rd stage	4 th stage	5 th stage	6 th stage	7 th stage
Stage number setting connector setting	 PIN1	 PIN1	 PIN1	 PIN1	 PIN1	 PIN1	 PIN1

POINT

- (1) To set the stage number setting connector, select the appropriate number from 1 through 7 in ascending order according to the number of expansion modules.
- (2) Do not assign the same stage number to several modules or skip any stage numbers. Otherwise, improper I/O operation results.
- (3) The extension stage number is factory-set to 1.

5. MOUNTING AND INSTALLATION

5.1 Module Installation

This section describes precautions for handling CPU modules, I/O modules, special function modules, power supply modules, and base units.

- (1) Do not drop or apply a strong impact to the module case, memory card, terminal block connectors, and pin connectors.
- (2) Do not remove the printed-circuit board of the modules from the case. Otherwise, malfunctions may result.
- (3) When using the extension base unit QA6□B, be sure to install the power supply module.
Although the module may work without the power supply module under light load, stable operation is not guaranteed.
- (4) Limit the tightening torque for the module installation screws and terminal block screws within the following range:

Location of screw	Tightening torque range
I/O module terminal block screw (M3)	36 to 48 N•cm
A series module fixing screw (M4)	78 to 118 N•cm
I/O module terminal block mounting screw (M4)	
Power supply module terminal screw (M4)	98 to 137 N•cm

5.2 Precautions for installing base unit

(1) Unit installation position

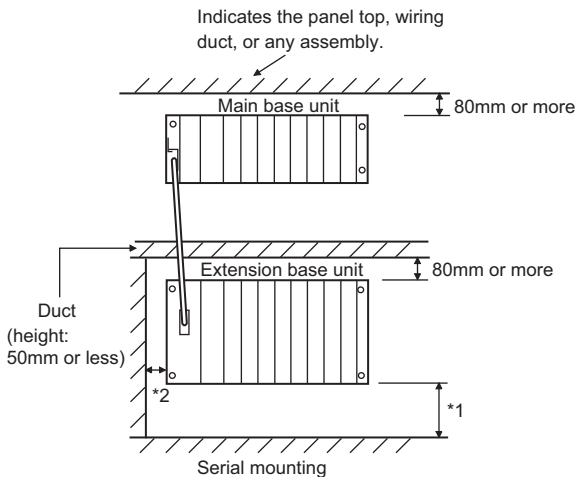
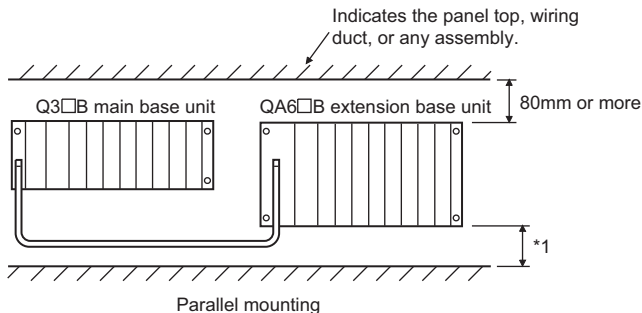

- *1 When link module is not used : 50mm or more
When using $\phi 4.5$ mm optical fiber cable : 100mm or more
When using a coaxial cable : 100mm or more
When using $\phi 8.5$ mm optical fiber cable : 130mm or more
- *2 20mm or more when connecting extension cable without removing adjacent modules.

(2) Module installing position

- (a) Install the PC in the following position to ensure ventilation for heat radiation.

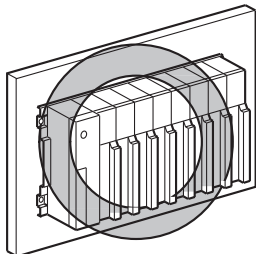

- (b) Do not install the PC in the following positions.

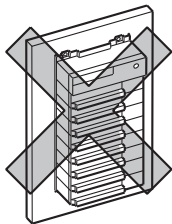

Vertical position

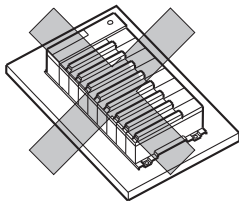

Horizontal position

- (3) Install the base unit on a flat surface.
When the base unit is installed on an uneven surface, the printed-circuit board may be strained, resulting in malfunction.
- (4) Do not install the PC close to a vibration source such as a large electromagnetic contactor or no-fuse breaker. Install the PC to the separate panel or isolate it as far as possible.
- (5) Provide the following distances between the PC and devices (contactor or relay) to avoid the influence of radiation noise or heat.
- Device installed in front of the PC: 100mm or more
 - Device installed on either side of the PC: 50mm or more

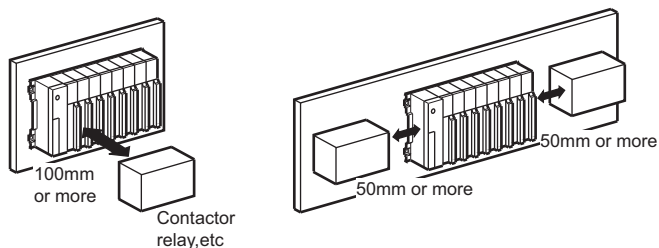

5.3 Installation and removal of modules

This section explains how to install and remove modules, such as the power supply module, CPU module, I/O module, special function module, to and from the base unit.

(1) Installation of module

Insert the two module fixing projections (two) into the module fixing hole (B) in the base unit.

Mount the module into the base unit by pushing it in the direction of the arrow.

Check if the hook of module is securely inserted in the module fixing hole (A) in the base unit.

Completed

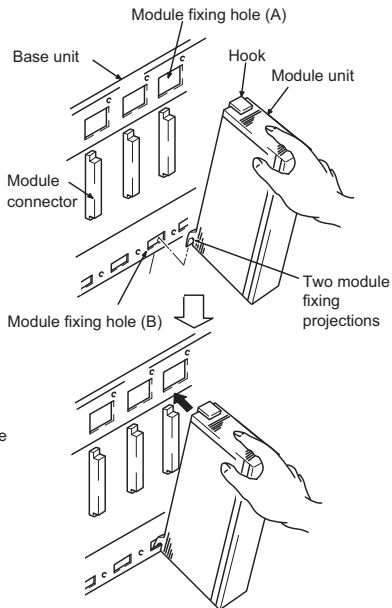
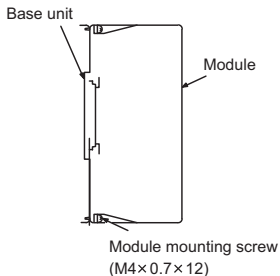

POINT

- (1) To fix the module, be sure to insert the module fixing projection into the module fixing hole (B). If the module is forcibly fixed without insertion, the pins in the module connector may be bent or damaged.
- (2) When the base unit is used at locations where there are especially large vibration and/or shock, screw the module to the base.

(2) Removal of module

Hold the module with both hands and push the hook latch at the top of module.

While pushing the hook latch, pull the module toward you.

Lift upwards and remove the module fixing projections from the module fixing hole (B).

Completed

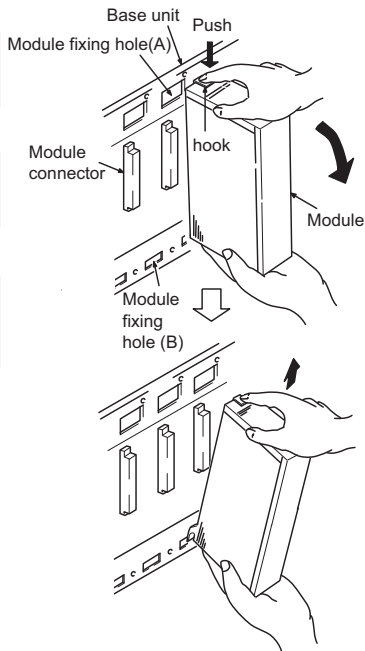

POINT

To remove the module, be sure to disengage the hook from the module fixing hole (A) and then remove the module fixing projections from the module fixing hole (B). If the module is forcibly removed, the hook or module fixing projections will be damaged.

6. EXTERNAL DIMENSIONS

The external dimensions of the QA6□B are shown below.

(1) The external dimensions of the QA68B

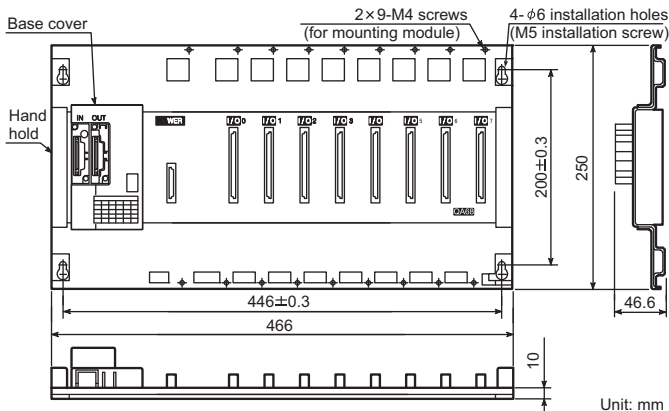

(2) The external dimensions of the QA65B

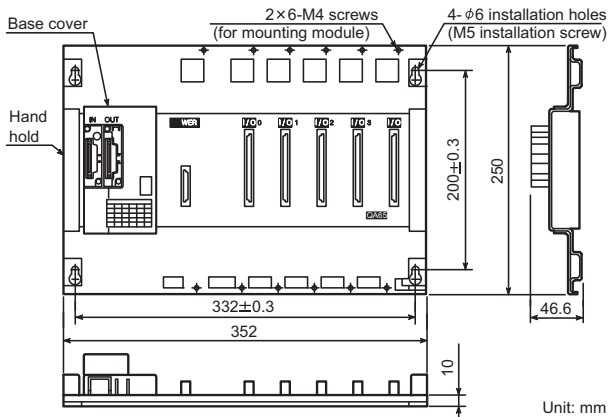

WARRANTY

Mitsubishi will not be held liable for damage caused by factors found not to be the cause of Mitsubishi; machine damage or lost profits caused by faults in the Mitsubishi products; damage, secondary damage, accident compensation caused by special factors unpredictable by Mitsubishi; damages to products other than Mitsubishi products; and to other duties.

Country/ Region	Sales office/ Tel	Country/ Region	Sales office/ Tel
USA	MITSUBISHI ELECTRIC AUTOMATION, INC. 500 Corporate Woods Parkway, Vernon Hills, IL 60061, U.S.A. Tel : +1-847-478-2100	Turkey	MITSUBISHI ELECTRIC TURKEY A.Ş Umraniye Branch Serifali Mahallesi Nutuk Sokak No:5, TR-34775 Umraniye/Istanbul, Turkey Tel : +90-216-526-3990
Mexico	MITSUBISHI ELECTRIC AUTOMATION, INC. Mexico Branch Mariano Escobedo #69, Col. Zona Industrial, Tlalpanpanita Edo. Mexico, C.P.54030 Tel : +52-55-3067-7500	UAE	MITSUBISHI ELECTRIC EUROPE B.V. Dubai Branch Dubai Silicon Oasis, P.O.BOX 341241, Dubai, U.A.E. Tel : +971-4-3724716
Brazil	MITSUBISHI ELECTRIC DO BRASIL COMÉRCIO E SERVIÇOS LTDA. Avenida Adelinio Cardana, 293, 21 andar, Bethaville, Barueri SP, Brazil Tel : +55-11-4689-3000	South Africa	ADROIT TECHNOLOGIES 20 Waterford Office Park, 189 Witkoppen Road, Fourways, South Africa Tel : +27-11-658-8100
Germany	MITSUBISHI ELECTRIC EUROPE B.V. German Branch Mitsubishi-Electric-Platz 1, 40882 Ratingen, Germany Tel : +49-2102-486-0	China	MITSUBISHI ELECTRIC AUTOMATION (CHINA) LTD. No.1386 Hongqiao Road, Mitsubishi Electric Automation Center, Shanghai, China Tel : +86-21-2322-3030
UK	MITSUBISHI ELECTRIC EUROPE B.V. UK Branch Travellers Lane, Hatfield, Hertfordshire, AL10 8XB, U.K. Tel : +44-1707-28-8780	Taiwan	SETSUYO ENTERPRISE CO., LTD. 6F, No.105, Wugong 3rd Road, Wugu District, New Taipei City 24889, Taiwan Tel : +886-2-2299-2499
Ireland	MITSUBISHI ELECTRIC EUROPE B.V. Irish Branch Westgate Business Park, Ballymount, Dublin 24, Ireland Tel : +353-1-4198800	Korea	MITSUBISHI ELECTRIC AUTOMATION KOREA CO., LTD. 7F-9F, Gangseo Hangang Xi-tower A, 401, Yangcheon-ro, Gangseo-Gu, Seoul 07528, Korea Tel : +82-2-3660-9530
Italy	MITSUBISHI ELECTRIC EUROPE B.V. Italian Branch Centro Direzionale Colleioli-Palazzo Sirio Viale Colleioli 7, 20864 Agrate Brianza(Milano) Italy Tel : +39-039-60531	Singapore	MITSUBISHI ELECTRIC ASIA PTE. LTD. 307, Alexandra Road, Mitsubishi Electric Building, Singapore 159943 Tel : +65-6473-2308
Spain	MITSUBISHI ELECTRIC EUROPE, B.V. Spanish Branch Carretera de Rubi, 76-80-Apdo. 420, 08190 Sant Cugat del Vallés (Barcelona), Spain Tel : +34-935-65-3131	Thailand	MITSUBISHI ELECTRIC FACTORY AUTOMATION (THAILAND) CO., LTD. 12th Floor, SV City Building, Office Tower 1, No. 896/19 and 20 Rama 3 Road, Kwaeng Bangpongpan, Khet Yannawa, Bangkok 10120, Thailand Tel : +66-2682-6522
France	MITSUBISHI ELECTRIC EUROPE B.V. French Branch 25, Boulevard des Bouvets, 92741 Nanterre Cedex, France Tel : +33-1-55-68-55-68	Vietnam	MITSUBISHI ELECTRIC VIETNAM COMPANY LIMITED Hanoi Branch 6th Floor, Detech Tower, 8 Ton That Thuyet Street, My Dinh 2 Ward, Nam Tu Liem District, Hanoi, Vietnam Tel : +84-4-3937-8075
Czech Republic	MITSUBISHI ELECTRIC EUROPE B.V. Czech Branch Avenir Business Park, Radlicka 751/113e, 158 00 Praha5, Czech Republic Tel : +420-251-551-470	Indonesia	PT. MITSUBISHI ELECTRIC INDONESIA Gedung Jaya 11th Floor, J.L. MH. Thamrin No.12, Jakarta Pusat 10340, Indonesia Tel : +62-21-3192-6461
Poland	MITSUBISHI ELECTRIC EUROPE B.V. Polish Branch ul. Krakowska 50, 32-083 Balice, Poland Tel : +48-12-347-65-00	India	MITSUBISHI ELECTRIC INDIA PVT. LTD. Pune Branch Emerald House, EL-3, J Block, M.I.D.C., Bhosari, Pune-411026, Maharashtra, India Tel : +91-20-2710-2000
Sweden	MITSUBISHI ELECTRIC EUROPE B.V. (Scandinavia) Fjellievägen 8, SE-22736 Lund, Sweden Tel : +46-8-625-10-00	Australia	MITSUBISHI ELECTRIC AUSTRALIA PTY. LTD. 348 Victoria Road, P.O. Box 11, Rydalmere, N.S.W 2116, Australia Tel : +61-2-9684-7777
Russia	MITSUBISHI ELECTRIC (RUSSIA) LLC St. Petersburg Branch Piskarevsky pr. 2, bld 2, lit "Sch", BC "Benua", office 720; 195027 St. Petersburg, Russia Tel : +7-812-633-3497		

MITSUBISHI ELECTRIC CORPORATION

HEAD OFFICE : TOKYO BUILDING, 2-7-3 MARUNOUCHI, CHIYODA-KU, TOKYO 100-8310, JAPAN
NAGOYA WORKS : 1-14, YADA-MINAMI 5-CHOME, HIGASHI-KU, NAGOYA, JAPAN

When exported from Japan, this manual does not require application to the Ministry of Economy,
Trade and Industry for service transaction permission.

Specifications subject to change without notice.