



Mitsubishi Electric Industrial Robot

RV-FR Series



INSTRUCTION MANUAL

ROBOT ARM SETUP & MAINTENANCE

RV-2FR series
RV-4FR series
RV-7FR series
RV-13FR series
RV-20FR series

Safety Precautions

Always read the following precautions and the separate "Safety Manual" before starting use of the robot to learn the required measures to be taken.

-  **CAUTION** All teaching work must be carried out by an operator who has received special training. (This also applies to maintenance work with the power source turned ON.)
Enforcement of safety training
-  **CAUTION** For teaching work, prepare a work plan related to the methods and procedures of operating the robot, and to the measures to be taken when an error occurs or when restarting. Carry out work following this plan. (This also applies to maintenance work with the power source turned ON.)
Preparation of work plan
-  **WARNING** Prepare a device that allows operation to be stopped immediately during teaching work. (This also applies to maintenance work with the power source turned ON.)
Setting of emergency stop switch
-  **CAUTION** During teaching work, place a sign indicating that teaching work is in progress on the start switch, etc. (This also applies to maintenance work with the power source turned ON.)
Indication of teaching work in progress
-  **DANGER** Provide a fence or enclosure during operation to prevent contact of the operator and robot.
Installation of safety fence
-  **CAUTION** Establish a set signaling method to the related operators for starting work, and follow this method.
Signaling of operation start
-  **CAUTION** As a principle turn the power OFF during maintenance work. Place a sign indicating that maintenance work is in progress on the start switch, etc.
Indication of maintenance work in progress
-  **CAUTION** Before starting work, inspect the robot, emergency stop switch and other related devices, etc., and confirm that there are no errors.
Inspection before starting work

The points of the precautions given in the separate "Safety Manual" are given below. Refer to the actual "Safety Manual" for details.

- ⚠ DANGER** When automatic operation of the robot is performed using multiple control devices (GOT, programmable controller, push-button switch), the interlocking of operation rights of the devices, etc. must be designed by the customer.
- ⚠ CAUTION** Use the robot within the environment given in the specifications. Failure to do so could lead to a drop or reliability or faults. (Temperature, humidity, atmosphere, noise environment, etc.)
- ⚠ CAUTION** Transport the robot with the designated transportation posture. Transporting the robot in a non-designated posture could lead to personal injuries or faults from dropping.
- ⚠ CAUTION** Always use the robot installed on a secure table. Use in an instable posture could lead to positional deviation and vibration.
- ⚠ CAUTION** Wire the cable as far away from noise sources as possible. If placed near a noise source, positional deviation or malfunction could occur.
- ⚠ CAUTION** Do not apply excessive force on the connector or excessively bend the cable. Failure to observe this could lead to contact defects or wire breakage.
- ⚠ CAUTION** Make sure that the workpiece weight, including the hand, does not exceed the rated load or tolerable torque. Exceeding these values could lead to errors or faults.
- ⚠ WARNING** Securely install the hand and tool, and securely grasp the workpiece. Failure to observe this could lead to personal injuries or damage if the object comes off or flies off during operation.
- ⚠ WARNING** Securely ground the robot and controller. Failure to observe this could lead to malfunctioning by noise or to electric shock accidents.
- ⚠ CAUTION** Indicate the operation state during robot operation. Failure to indicate the state could lead to operators approaching the robot or to incorrect operation.
- ⚠ WARNING** When carrying out teaching work in the robot's movement range, always secure the priority right for the robot control. Failure to observe this could lead to personal injuries or damage if the robot is started with external commands.
- ⚠ CAUTION** Keep the jog speed as low as possible, and always watch the robot. Failure to do so could lead to interference with the workpiece or peripheral devices.
- ⚠ CAUTION** After editing the program, always confirm the operation with step operation before starting automatic operation. Failure to do so could lead to interference with peripheral devices because of programming mistakes, etc.
- ⚠ CAUTION** Make sure that if the safety fence entrance door is opened during automatic operation, the door is locked or that the robot will automatically stop. Failure to do so could lead to personal injuries.
- ⚠ CAUTION** Never carry out modifications based on personal judgments, or use non-designated maintenance parts. Failure to observe this could lead to faults or failures.

 **WARNING**

When the robot arm has to be moved by hand from an external area, do not place hands or fingers in the openings. Failure to observe this could lead to hands or fingers catching depending on the posture.

 **CAUTION**

Do not stop the robot or apply emergency stop by turning the robot controller's main power OFF. If the robot controller main power is turned OFF during automatic operation, the robot accuracy could be adversely affected. Moreover, it may interfere with the peripheral device by drop or move by inertia of the arm.

 **CAUTION**

Do not turn off the main power to the robot controller while rewriting the internal information of the robot controller such as the program or parameters. If the main power to the robot controller is turned off while in automatic operation or rewriting the program or parameters, the internal information of the robot controller may be damaged.

 **DANGER**

Do not connect the Handy GOT when using the GOT direct connection function of this product. Failure to observe this may result in property damage or bodily injury because the Handy GOT can automatically operate the robot regardless of whether the operation rights are enabled or not.

 **DANGER**

Do not connect the Handy GOT to a programmable controller when using an iQ Platform compatible product with the CR800-R/CR800-Q controller. Failure to observe this may result in property damage or bodily injury because the Handy GOT can automatically operate the robot regardless of whether the operation rights are enabled or not.

 **DANGER**

Do not remove the SSCNET III cable while power is supplied to the multiple CPU system or the servo amplifier. Do not look directly at light emitted from the tip of SSCNET III connectors or SSCNET III cables of the Motion CPU or the servo amplifier. Eye discomfort may be felt if exposed to the light. (Reference: SSCNET III employs a Class 1 or equivalent light source as specified in JIS C 6802 and IEC60825-1 (domestic standards in Japan).)

 **DANGER**

Do not remove the SSCNET III cable while power is supplied to the controller. Do not look directly at light emitted from the tip of SSCNET III connectors or SSCNET III cables. Eye discomfort may be felt if exposed to the light. (Reference: SSCNET III employs a Class 1 or equivalent light source as specified in JIS C 6802 and IEC60825-1 (domestic standards in Japan).)

 **DANGER**

Attach the cap to the SSCNET III connector after disconnecting the SSCNET III cable. If the cap is not attached, dirt or dust may adhere to the connector pins, resulting in deterioration connector properties, and leading to malfunction.

 **CAUTION**

Make sure there are no mistakes in the wiring. Connecting differently to the way specified in the manual can result in errors, such as the emergency stop not being released. In order to prevent errors occurring, please be sure to check that all functions (such as the teaching box emergency stop, customer emergency stop, and door switch) are working properly after the wiring setup is completed.

CAUTION

Use the network equipments (personal computer, USB hub, LAN hub, etc) confirmed by manufacturer. The thing unsuitable for the FA environment (related with conformity, temperature or noise) exists in the equipments connected to USB. When using network equipment, measures against the noise, such as measures against EMI and the addition of the ferrite core, may be necessary. Please fully confirm the operation by customer. Guarantee and maintenance of the equipment on the market (usual office automation equipment) cannot be performed.

CAUTION

To maintain the security (confidentiality, integrity, and availability) of the robot and the system against unauthorized access, DoS*¹ attacks, computer viruses, and other cyberattacks from unreliable networks and devices via network, take appropriate measures such as firewalls, virtual private networks (VPNs), and antivirus solutions.

Mitsubishi Electric shall have no responsibility or liability for any problems involving robot trouble and system trouble by unauthorized access, DoS attacks, computer viruses, and other cyberattacks.

*1 DoS: A denial-of-service (DoS) attack disrupts services by overloading systems or exploiting vulnerabilities, resulting in a denial-of-service (DoS) state.

*CR800 controller

Notes of the basic component are shown.

⚠ CAUTION Please install the earth leakage breaker in the primary side power supply of the controller because of leakage protection.

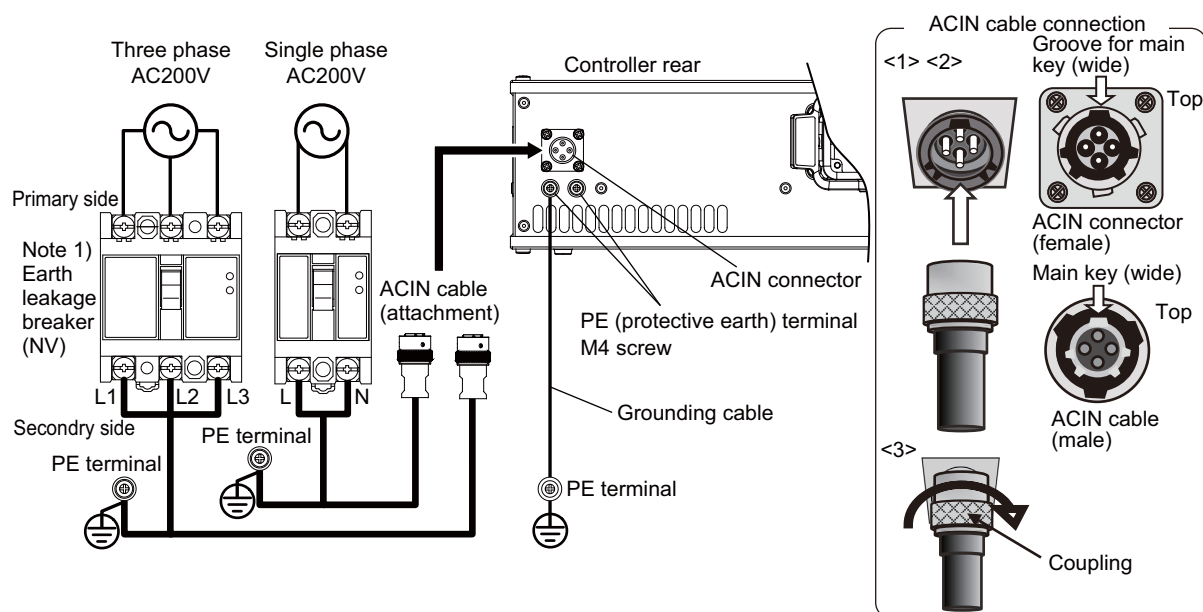

Note 1) Always use the terminal cover for the earth leakage breaker.

1) Prepare the following items.

Part name	Specifications	Remarks
Earth leakage breaker	The following is recommended product. Single phase: NV30FAU-2P-10A-AC100-240V-30mA (Terminal cover: TCS-05FA2) Three phase: NV30FAU-3P-10A-AC100-240V-30mA (Terminal cover: TCS-05FA3)	Prepared by customer.
Cable for primary power supply	AWG14 (2mm ²) or above	Prepared by customer. Tightening torque for terminal fixing screw is 2 ~ 3Nm.
Grounding cable	AWG14 (2mm ²) or above	Prepared by customer. Tightening torque for terminal fixing screw is 2 ~ 3Nm.
ACIN cable	Terminal: M5, cable length: 3m	Supplied with the product.

- 2) Confirm that the primary power matches the specifications.
- 3) Confirm that the primary power is OFF and that the earth leakage breaker power switch is OFF.
- 4) Connect the ACIN cable to the breaker.
Connect the power terminals of the ACIN cable to the secondary side terminals of the earth leakage breaker. Also, ground the FG terminal of the cable.
- 5) Connect the ACIN cable to the ACIN connector on the rear of the controller.
 - <1> Face the main key on the ACIN cable plug upwards. (Refer to the "ACIN cable connection" illustration.)
 - <2> Align the main key of the ACIN cable plug with the grooves on the ACIN connector. Push the plug into the connector as far as it will go.
The plug may be damaged if it is not correctly aligned with the connector.
 - <3> Tighten the coupling on the ACIN cable, turning it to the right until it locks.
- 6) Connect one end of the grounding cable to the PE (protective earth) terminal on the controller and ground the other end (2-point grounding) in order to comply with the requirements of EN 61800-5-1 for the touch current of 3.5 mA AC or more.
- 7) Connect the primary power cable to the primary side terminal of the earth leakage breaker.

Revision history

Date of Print	Instruction Manual No.	Revision Details
2017-04-28	BFP-A3474	<ul style="list-style-type: none"> First print
2017-07-10	BFP-A3474-A	<ul style="list-style-type: none"> "(10) RV-4FR/7FR series: Inspection and replacement of J3-axis timing belt" was modified.
2018-03-01	BFP-A3474-B	<ul style="list-style-type: none"> Descriptions of CR800-Q controller were added. Transportation postures of robot were added.
2018-09-01	BFP-A3474-C	<ul style="list-style-type: none"> Tension for new belt installation of J6 axis of RV-4FR series was corrected.
2018-12-25	BFP-A3474-D	<ul style="list-style-type: none"> "5.6.3 ABS origin method" was corrected. Added further explanation of the ACIN cable.
2020-01-24	BFP-A3474-E	<ul style="list-style-type: none"> Corrected the length of the installation screw used for installing the RV-4FR/7FR series elbow cover. (Table 5-5) Correction of figures in "5.3.3 Inspection replacement of timing belt". (Fig. 5-12, 25, 26)
2020-10-30	BFP-A3474-F	<ul style="list-style-type: none"> Amended the precautions regarding the prevention of unauthorized access. Corrected other mistakes and changed some sections.
2021-04-01	BFP-A3474-G	<ul style="list-style-type: none"> Added the Safety Communication Function Instruction Manual in "1.1.1 The details of each instruction manuals".
2021-09-30	BFP-A3474-H	<ul style="list-style-type: none"> Corrected other mistakes and changed some sections.
2022-01-31	BFP-A3474-J	<ul style="list-style-type: none"> Corrected other mistakes and changed some sections.
2022-02-24	BFP-A3474-K	<ul style="list-style-type: none"> Software version C2d supported. Added descriptions to "2.3.2 Turning ON the control power". Added the parameter HNDCHK to "Table 2-5: Hand parameter".
2022-06-30	BFP-A3474-M	<ul style="list-style-type: none"> Corrected "(10) RV-4FR/7FR series: Inspection and replacement of J3-axis timing belt".
2022-11-30	BFP-A3474-N	<ul style="list-style-type: none"> Added description on handling of the thermal conductive sheet when attaching/detaching the cover. Added descriptions on the specifications of the all-in-one packaging for RV-4FR/7FR series. Corrected other mistakes and changed some sections.
2023-04-17	BFP-A3474-P	<ul style="list-style-type: none"> Software version C2j supported. Added precautions to "5.6.4 User origin method". Corrected other mistakes and changed some sections.
2023-09-14	BFP-A3474-Q	<ul style="list-style-type: none"> Added Caution to "5.3.5 (1) Replacing the battery of the robot arm". Deleted RV-4FRJL. Changed some sections.
2024-04-05	BFP-A3474-R	<ul style="list-style-type: none"> Corrected mistakes and changed some sections.

*Introduction

Thank you for purchasing the Mitsubishi industrial robot.

This instruction manual explains the method of unpacking, installation and maintenance and inspection of the robot arm.

Always read through this manual before starting use to ensure correct usage of the robot.

The information contained in this document has been written to be accurate as much as possible. Please interpret that items not described in this document "cannot be performed."

This document explains for the following robot type.

Robot type	Series (generic name used in this document for robots listed in each row)
RV-2FR-D/R/Q, RV-2FRL-D/R/Q, RV-2FRB-D/R/Q, RV-2FRLB-D/R/Q	RV-2FR series
RV-4FR-D/R/Q, RV-4FRL-D/R/Q	RV-4FR series
RV-7FR-D/R/Q, RV-7FRL-D/R/Q	RV-7FR series
RV-7FRLL-D/R/Q, RV-13FR-D/R/Q, RV-13FRL-D/R/Q, RV-20FR-D/R/Q	RV-13FR series

- No part of this manual may be reproduced by any means or in any form, without prior consent from Mitsubishi.
- The details of this manual are subject to change without notice.
- The information contained in this document has been written to be accurate as much as possible. Please interpret that items not described in this document "cannot be performed" or "error may occur". Please contact your nearest dealer if you find any doubtful, wrong or skipped point.
- This is the original document.
- Company names and production names in this document are the trademarks or registered trademarks of their respective owners.

CONTENTS

	Page
1 Before starting use	1-1
1.1 Using the instruction manuals	1-1
1.1.1 Details of each instruction manual	1-1
1.1.2 Symbols used in instruction manual	1-2
1.2 Safety Precautions	1-3
1.2.1 Precautions given in the separate Safety Manual	1-4
2 Unpacking to Installation	2-6
2.1 Confirming the product	2-6
2.2 Installation	2-10
2.2.1 Unpacking	2-10
(1) RV-2FR/2FRB	2-10
(2) RV-2FRL/2FRLB	2-11
(3) RV-4FR/7FR series robot alone packaging specifications, RV-13FR series	2-12
(4) RV-4FR/7FR series all-in-one packaging specifications	2-13
2.2.2 Transportation procedures (Transportation by people)	2-14
2.2.3 Transportation procedures (Transporting with a crane)	2-16
2.2.4 Installation procedures	2-18
2.2.5 Grounding procedures	2-21
(1) Grounding methods	2-21
(2) Grounding procedures	2-21
2.2.6 Connecting with the controller	2-22
(1) Connection of robot arm and machine cable	2-22
(2) Connection of controller and machine cable	2-24
2.2.7 About oil mist specification	2-25
(1) Piping for pressurization inside robot arm	2-25
2.2.8 About clean specification	2-25
(1) Piping for suction inside robot arm	2-25
2.3 Confirming the operation	2-26
2.3.1 Installing the teaching pendant (T/B)	2-27
2.3.2 Turning ON the control power	2-27
2.3.3 Preparing the T/B	2-28
(1) JOINT jog operation	2-32
(2) XYZ jog operation	2-34
(3) TOOL jog operation	2-36
(4) 3-axis XYZ jog operation	2-38
(5) CYLINDER jog operation	2-40
(6) Work jog operation	2-42
2.3.4 Setting the hand parameters	2-49
3 Installing the option devices	3-50
3.1 Installing the operating range change (RV-2FR series)	3-50
3.1.1 Installing the J1 axis operating range change	3-50
(1) Configuration	3-50
(2) Changeable angle	3-50
(3) Installation procedure	3-51
(4) Setting the parameter	3-51
(5) Check the operating range	3-52
3.1.2 Installing the J2 axis operating range change	3-52
(1) Configuration	3-52
(2) Changeable angle	3-52
(3) Installation procedure	3-53
(4) Setting the parameter	3-53
(5) Check the operating range	3-54
3.1.3 Installing the J3 axis operating range change	3-54
(1) Configuration	3-54
(2) Changeable angle	3-54

CONTENTS

	Page
(3) Installation procedure	3-55
(4) Setting the parameter	3-55
(5) Check the operating range	3-56
3.2 Installing the J1 axis operating range change (RV-4FR/7FR/13FR series)	3-57
3.2.1 RV-4FR/7FR series	3-57
(1) Configuration	3-57
(2) Changeable angle	3-58
(3) Installation procedure	3-60
(4) Setting the parameter	3-61
(5) Check the operating range	3-61
3.2.2 RV-13FR series	3-62
(1) Configuration	3-62
(2) Changeable	3-62
(3) Installation procedure	3-64
(4) Setting the parameter	3-66
(5) Check the operating range	3-66
3.3 Installing the solenoid valve set	3-67
(1) RV-2FR series	3-67
3.3.1 RV-4FR/7FR series, RV-7FRL	3-69
(1) RV-4FR/7FR series, RV-7FRL	3-70
(2) RV-13FR/13FRL, RV-20FR	3-79
3.4 Installing the hand input cable	3-83
(1) RV-4FR/7FR/13FR series	3-83
3.5 Installing the hand output cable	3-85
(1) RV-4FR/7FR/13FR series	3-85
3.6 Installing the forearm external wiring set/base external wiring set	3-89
3.6.1 Installing the forearm external wiring set	3-90
3.6.2 Installing the base external wiring set	3-92
4 Basic operations	4-94
5 Maintenance and Inspection	5-95
5.1 Type of inspection and maintenance works	5-95
5.2 Inspection items	5-96
5.2.1 Daily inspection items	5-96
5.2.2 Periodic inspection	5-97
(1) Inspection item	5-97
(2) Schedule	5-98
5.3 Maintenance and inspection procedures	5-99
5.3.1 Robot arm structure	5-99
(1) RV-2FR series	5-99
5.3.2 Installing/removing the cover	5-103
(1) RV-2FR series	5-103
(2) RV-4FR/7FR series	5-105
(3) RV-13FR series	5-107
5.3.3 Inspection replacement of timing belt	5-109
(1) Timing belt replacement period	5-110
(2) Timing belt tension measurement	5-111
(3) RV-2FR series: Inspection and replacement of J1-axis timing belt	5-112
(4) RV-2FR series: Inspection and replacement of J2-axis timing belt	5-114
(5) RV-2FR series: Inspection and replacement of J3-axis timing belt	5-116
(6) RV-2FR series: Inspection and replacement of J4-axis timing belt	5-118
(7) RV-2FR series: Inspection and replacement of J5 axis timing belt and brake timing belt	5-120
(8) RV-2FR series: Inspection and replacement of J6-axis timing belt and brake timing belt	5-124
(9) RV-4FR/7FR series: Inspection and replacement of J1-axis timing belt	5-128
(10) RV-4FR/7FR series: Inspection and replacement of J3-axis timing belt	5-130
(11) RV-4FR/7FR series (6-axes type): Inspection and replacement of J4-axis timing belt	5-133

CONTENTS

	Page
(12) RV-13FR series: Inspection and replacement of J4-axis timing belt	5-134
(13) RV-4FR/7FR/13FR series: Inspection and replacement of J5 axis timing belt	5-135
(14) RV-4FR/7FR/13FR series: Inspection and replacement of J6-axis timing belt	5-137
(15) Timing belt tension	5-139
(16) Amount of movement of each axis during the timing belt tension measurement	5-140
5.3.4 Lubrication	5-141
(1) RV-2FR series	5-141
(2) RV-4FR/7FR/13FR series	5-143
5.3.5 Replacing the backup battery	5-147
(1) Replacing the battery of the robot arm	5-148
5.4 About Overhaul	5-151
5.5 Maintenance parts	5-152
5.6 Resetting the origin	6-155
5.6.1 Setting the origin with the origin data input method	6-156
(1) Confirming the origin data	6-156
(2) Selecting the origin setting method	6-157
(3) Inputting the origin data	6-158
(4) Installing the cover	6-159
5.6.2 Jig method	5-160
(1) J1 axis origin setting (jig)	5-161
(2) J2 axis origin setting (jig)	5-164
(3) J3 axis origin setting (jig)	5-168
(4) J4 axis origin setting (6-axis type robot only)	5-172
(5) Origin setting of J5 axis and J6 axis (jig)	5-175
5.6.3 ABS origin method	5-180
(1) RV-2FR series	5-180
(2) RV-4FR series	5-181
(3) RV-7FR series	5-182
(4) RV-13FR series	5-183
(5) Origin setting procedure	5-184
5.6.4 User origin method	5-185
5.6.5 Recording the origin data	5-187
(1) Confirming the origin data label	5-187
(2) Confirming the origin data	5-187
(3) Recording the origin data	5-187
(4) Installing the cover	5-187
5.7 How to release the brake in an emergency	5-188
6Appendix	Appendix-190
Appendix 1 : Configuration flag	Appendix-190

1 Before starting use

This chapter explains the details and usage methods of the instruction manuals, the basic terminology and the safety precautions. Moreover, handling and operation of a teaching pendant (T/B) are described based on R32TB in instruction manuals. If using other T/B, such as R56TB, refer to a supplied instruction manual of the T/B.

1.1 Using the instruction manuals

1.1.1 Details of each instruction manual

The contents and purposes of the documents enclosed with this product are shown below. Use these documents according to the application.



For special specifications, a separate instruction manual describing the special section may be enclosed.

Manual name	Description
Safety Manual	Explains the common precautions and safety measures to be taken for robot handling, system design and manufacture to ensure safety of the operators involved with the robot.
Standard Specifications	Explains the product's standard specifications, factory-set special specifications, option configuration and maintenance parts, etc. Precautions for safety and technology, when incorporating the robot, are also explained.
Robot Arm Setup & Maintenance	Explains the procedures required to operate the robot arm (unpacking, transportation, installation, confirmation of operation), and the maintenance and inspection procedures.
Controller setup, basic operation, and maintenance	Explains the procedures required to operate the controller (unpacking, transportation, installation, confirmation of operation), basic operation from creating the program to automatic operation, and the maintenance and inspection procedures.
Detailed explanations of functions and operations	Explains details on the functions and operations such as each function and operation, commands used in the program, connection with the external input/output device, and parameters, etc.
Troubleshooting	Explains the causes and remedies to be taken when an error occurs. Explanations are given for each error No.
Additional axis function	Explains the specifications, functions and operations of the additional axis control.
Tracking Function	Explains the control function and specifications of conveyor tracking.
GOT Direct Connection Extended Function	Explains the detailed description of data configuration of shared memory, monitoring, and operating procedures about the GOT (standalone type robot).
iQ Platform Supporting Extended Function	Explains the detailed description of data configuration of shared memory, monitoring, and operating procedures about the PLC (iQ Platform compatible type robot).
Safety communication function	Explains about the safety communication function which expands the robot safety functions by communicating safely with a safety programmable controller.
Ethernet Function	Explains the measures to perform communication with personal computers on Ethernet with the TCP/IP protocol.

1.1.2 Symbols used in instruction manual









The symbols and expressions shown in [Table 1-1](#) are used throughout this instruction manual. Learn the meaning of these symbols before reading this instruction manual.

Table 1-1: Symbols in instruction manual

Terminology	Item/Symbol	Meaning
Item	iQ Platform compatible type	
	Controller	Indicates the controller which controls the robot arm.
	The robot CPU unit or robot CPU	Indicates the CPU unit for the robots which installed to the sequencer base unit of MELSEC iQ-R/MELSEC-Q series. It is connected with the controller by the dedicated cable.
	The robot CPU system	Multi-CPU system. It consists of MELSEC units, such as the sequencer base unit, the sequencer CPU unit, and the robot CPU unit, etc.
	Standalone type	
	Controller	Indicates the controller which controls the robot arm.
Symbol	 DANGER	Precaution indicating cases where there is a risk of operator fatality or serious injury if handling is mistaken. Always observe these precautions to safely use the robot.
	 WARNING	Precaution indicating cases where the operator could be subject to fatalities or serious injuries if handling is mistaken. Always observe these precautions to safely use the robot.
	 CAUTION	Precaution indicating cases where operator could be subject to injury or physical damage could occur if handling is mistaken. Always observe these precautions to safely use the robot.
	[JOG]	If a word is enclosed in brackets or a box in the text, this refers to a key on the teaching pendant.
	[RESET] + [EXE] (A) (B)	This indicates to press the (B) key while holding down the (A) key. In this example, the [RESET] key is pressed while holding down the [EXE] key.
	T/B	This indicates the teaching pendant. Descriptions in this manual are based on R32TB.

1.2 Safety Precautions

Always read the following precautions and the separate "Safety Manual" before starting use of the robot to learn the required measures to be taken.

-  **CAUTION** All teaching work must be carried out by an operator who has received special training. (This also applies to maintenance work with the power source turned ON.)
Enforcement of safety training
-  **CAUTION** For teaching work, prepare a work plan related to the methods and procedures of operating the robot, and to the measures to be taken when an error occurs or when restarting. Carry out work following this plan. (This also applies to maintenance work with the power source turned ON.)
Preparation of work plan
-  **WARNING** Prepare a device that allows operation to be stopped immediately during teaching work. (This also applies to maintenance work with the power source turned ON.)
Setting of emergency stop switch
-  **CAUTION** During teaching work, place a sign indicating that teaching work is in progress on the start switch, etc. (This also applies to maintenance work with the power source turned ON.)
Indication of teaching work in progress
-  **DANGER** Provide a fence or enclosure during operation to prevent contact of the operator and robot.
Installation of safety fence
-  **CAUTION** Establish a set signaling method to the related operators for starting work, and follow this method.
Signaling of operation start
-  **CAUTION** As a principle turn the power OFF during maintenance work. Place a sign indicating that maintenance work is in progress on the start switch, etc.
Indication of maintenance work in progress
-  **CAUTION** Before starting work, inspect the robot, emergency stop switch and other related devices, etc., and confirm that there are no errors.
Inspection before starting work

1.2.1 Precautions given in the separate Safety Manual

The points of the precautions given in the separate "Safety Manual" are given below. Refer to the actual "Safety Manual" for details.

 **DANGER**

When automatic operation of the robot is performed using multiple control devices (GOT, programmable controller, push-button switch), the interlocking of operation rights of the devices, etc. must be designed by the customer.

 **CAUTION**

Use the robot within the environment given in the specifications. Failure to do so could lead to a drop or reliability or faults. (Temperature, humidity, atmosphere, noise environment, etc.)

 **CAUTION**

Transport the robot with the designated transportation posture. Transporting the robot in a non-designated posture could lead to personal injuries or faults from dropping.

 **CAUTION**

Always use the robot installed on a secure table. Use in an instable posture could lead to positional deviation and vibration.

 **CAUTION**

Wire the cable as far away from noise sources as possible. If placed near a noise source, positional deviation or malfunction could occur.

 **CAUTION**

Do not apply excessive force on the connector or excessively bend the cable. Failure to observe this could lead to contact defects or wire breakage.

 **CAUTION**

Make sure that the workpiece weight, including the hand, does not exceed the rated load or tolerable torque. Exceeding these values could lead to errors or faults.

 **WARNING**

Securely install the hand and tool, and securely grasp the workpiece. Failure to observe this could lead to personal injuries or damage if the object comes off or flies off during operation.

 **WARNING**

Securely ground the robot and controller. Failure to observe this could lead to malfunctioning by noise or to electric shock accidents.

 **CAUTION**

Indicate the operation state during robot operation. Failure to indicate the state could lead to operators approaching the robot or to incorrect operation.

 **WARNING**

When carrying out teaching work in the robot's movement range, always secure the priority right for the robot control. Failure to observe this could lead to personal injuries or damage if the robot is started with external commands.

 **CAUTION**

Keep the jog speed as low as possible, and always watch the robot. Failure to do so could lead to interference with the workpiece or peripheral devices.

 **CAUTION**

After editing the program, always confirm the operation with step operation before starting automatic operation. Failure to do so could lead to interference with peripheral devices because of programming mistakes, etc.

 **CAUTION**

Make sure that if the safety fence entrance door is opened during automatic operation, the door is locked or that the robot will automatically stop. Failure to do so could lead to personal injuries.

 **CAUTION**

Never carry out modifications based on personal judgments, or use non-designated maintenance parts. Failure to observe this could lead to faults or failures.

 **WARNING**

When the robot arm has to be moved by hand from an external area, do not place hands or fingers in the openings. Failure to observe this could lead to hands or fingers catching depending on the posture.

⚠ CAUTION

Do not stop the robot or apply emergency stop by turning the robot controller's main power OFF.
If the robot controller main power is turned OFF during automatic operation, the robot accuracy could be adversely affected.

⚠ CAUTION

Do not turn off the main power to the robot controller while rewriting the internal information of the robot controller such as the program or parameters. If the main power to the robot controller is turned off while in automatic operation or rewriting the program or parameters, the internal information of the robot controller may be damaged.

⚠ CAUTION

Do not connect the Handy GOT when using the GOT direct connection function of this product. Failure to observe this may result in property damage or bodily injury because the Handy GOT can automatically operate the robot regardless of whether the operation rights are enabled or not.

⚠ DANGER

Do not connect the Handy GOT to a programmable controller when using an iQ Platform compatible product with the CR800-R/CR800-Q controller. Failure to observe this may result in property damage or bodily injury because the Handy GOT can automatically operate the robot regardless of whether the operation rights are enabled or not.

⚠ DANGER

Do not remove the SSCNET III cable while power is supplied to the multiple CPU system or the servo amplifier. Do not look directly at light emitted from the tip of SSCNET III connectors or SSCNET III cables of the Motion CPU or the servo amplifier. Eye discomfort may be felt if exposed to the light. (Reference: SSCNET III employs a Class 1 or equivalent light source as specified in JIS C 6802 and IEC60825-1 (domestic standards in Japan).)

⚠ DANGER

Do not remove the SSCNET III cable while power is supplied to the controller. Do not look directly at light emitted from the tip of SSCNET III connectors or SSCNET III cables. Eye discomfort may be felt if exposed to the light. (Reference: SSCNET III employs a Class 1 or equivalent light source as specified in JIS C 6802 and IEC60825-1 (domestic standards in Japan).)

⚠ DANGER

Attach the cap to the SSCNET III connector after disconnecting the SSCNET III cable. If the cap is not attached, dirt or dust may adhere to the connector pins, resulting in deterioration connector properties, and leading to malfunction.

⚠ CAUTION

Make sure there are no mistakes in the wiring. Connecting differently to the way specified in the manual can result in failures, such as the emergency stop not being released. In order to prevent from occurring, please be sure to check that all functions (such as the teaching box emergency stop, customer emergency stop, and door switch) are working properly after the wiring setup is completed

⚠ CAUTION

Use the network equipments (personal computer, USB hub, LAN hub, etc) confirmed by manufacturer. The thing unsuitable for the FA environment (related with conformity, temperature or noise) exists in the equipments connected to USB. When using network equipment, measures against the noise, such as measures against EMI and the addition of the ferrite core, may be necessary. Please fully confirm the operation by customer. Guarantee and maintenance of the equipment on the market (usual office automation equipment) cannot be performed.

⚠ CAUTION

To maintain the security (confidentiality, integrity, and availability) of the robot and the system against unauthorized access, DoS^{*1} attacks, computer viruses, and other cyberattacks from unreliable networks and devices via network, take appropriate measures such as firewalls, virtual private networks (VPNs), and antivirus solutions.

Mitsubishi Electric shall have no responsibility or liability for any problems involving robot trouble and system trouble by unauthorized access, DoS attacks, computer viruses, and other cyberattacks.

*1 DoS: A denial-of-service (DoS) attack disrupts services by overloading systems or exploiting vulnerabilities, resulting in a denial-of-service (DoS) state.

2 Unpacking to Installation

2.1 Confirming the product

The standard configuration of the robot arm, part of the purchased product, is shown in [Table 2-1](#).

Confirm the parts.

Users who have purchased optional products should refer to the separate “Standard Specifications”.

Table 2-1 : Standard configuration

No.	Part name	Type	Qty.	Remarks
RV-2FR series				
1	Robot arm	RV-2FR series	Either 1 unit	
2	Installation bolts	M8x35	4 pcs.	
3	Spring washer for installation bolts	For M8	4 pcs.	
4	Plain washer for installation bolts	For M8	4 pcs.	
5	Fixing plate A		1 pc.	Pre-installed on the robot.
6	Safety socket for fixing plate A	M5x12	3 pcs.	
	Plain washer for fixing plate A	For M5	3 pcs.	
7	Fixing plate B		1 pc.	
8	Safety socket for fixing plate B	M5x12	3 pcs.	
9	Plain washer for fixing plate B	For M5	3 pcs.	
10	Fixing plates C		1 pc.	Pre-installed on the RV-2FRL/2FRLB robot.
11	Safety socket for fixing plate C	M3x12	2 pcs.	
12	Grease nipple	For J5 and J6 reducers, J6 gears	3 pcs.	

No.	Part name	Type	Qty.	Remarks
RV-4FR series				
1	Robot arm	RV-4FR series	Either 1 unit	
2	Installation bolts	M8 x 40	4 pcs.	For robot arm installation
3	Spring washer for installation bolts	For M8	4 pcs.	
4	Plain washer for installation bolts	For M8	4 pcs.	
5	Grease nipple	WA-610	5 pc.	
6	Coupling front side	φ 4	4 pcs.	Supplied for the following internal wiring and piping specification. -SH01
7	Coupling back side	φ 4	4 pcs.	
8	Air hose	φ 4	4 pcs.	
9	Coupling front side	φ 4	2 pcs.	Supplied for the following internal wiring and piping specification. -SH04, -SH05
10	Coupling back side	φ 4	2 pcs.	
11	Air hose	φ 4	2 pcs.	
12	Ferrite core	E04SR301334	1 pc.	Supplied for the following internal wiring and piping specification. -SH02, -SH03, -SH04
13	Transporting jig		2 sets	
14	Transporting jig installation bolt	M6 x 20	6 pcs.	
15	Plain washer for suspension fitting installation bolt	For M6	6 pcs.	
16	Eye bolt	M10	4 pcs.	
17	Nut for eye bolt	For M10	4 pcs.	
18	Fixing plate		1 set	
19	Fixing screw	M15 x 12	4 pcs.	For the robot alone packaging specifications, use the screws in combination with fixing flat washers (1 mm thick).
		M15 x 14	4 pcs.	For the all-in-one packaging specifications, use the screws in combination with fixing flat washers (3 mm thick).
20	Plain washer for fixing plate	For M5 (1 mm thick)	4 pcs.	For the robot alone packaging specifications, use the washers in combination with fixing screws M5 x 12.
		For M5 (3 mm thick)	4 pcs.	For the all-in-one packaging specifications, use the washers in combination with fixing screws M5 x 14.
21	Base external wiring and piping set	1F-HA01S-01	1 pc.	Pre-installed on the following internal wiring and piping specification. -SH02, -SH04, -SH05
22	Base external wiring and piping set	1F-HA02S-01	1 pc.	Pre-installed on the following internal wiring and piping specification. -SH03

No.	Part name	Type	Qty.	Remarks
RV-7FR series				
1	Robot arm	RV-7FR series	Either 1 unit	
2	Installation bolts	M8 x 40	4 pcs.	For robot arm installation
3	Spring washer for installation bolts	For M8	4 pcs.	
4	Plain washer for installation bolts	For M8	4 pcs.	
5	Grease nipple	WA-610	4 pcs.	
6	Coupling front side	φ 4	4 pcs.	Supplied for the following internal wiring and piping specification. -SH01
7	Coupling back side	φ 4	4 pcs.	
8	Air hose	φ 4	4 pcs.	
9	Coupling front side	φ 4	2 pcs.	Supplied for the following internal wiring and piping specification. -SH04, -SH05
10	Coupling back side	φ 4	2 pcs.	
11	Air hose	φ 4	2 pcs.	
12	Ferrite core	E04SR301334	1 pc.	Supplied for the following internal wiring and piping specification. -SH02, -SH03, -SH04
13	Transporting jig		2 sets	
14	Transporting jig installation bolt	M8 x 25	4 pcs.	
15	Plain washer for suspension fitting installation bolt	For M8	4 pcs.	
16	Eye bolt	M10	4 pcs.	
17	Nut for eye bolt	For M10	4 pcs.	
18	Fixing plate		1 set	
19	Fixing screw	M15 x 12	4 pcs.	For the robot alone packaging specifications, use the screws in combination with fixing flat washers (1 mm thick).
		M15 x 14	4 pcs.	For the all-in-one packaging specifications, use the screws in combination with fixing flat washers (3 mm thick).
20	Plain washer for fixing plate	For M5 (1 mm thick)	4 pcs.	For the robot alone packaging specifications, use the washers in combination with fixing screws M5 x 12.
		For M5 (3 mm thick)	4 pcs.	For the all-in-one packaging specifications, use the washers in combination with fixing screws M5 x 14.
21	Base external wiring and piping set	1F-HA01S-01	1 pc.	Pre-installed on the following internal wiring and piping specification. -SH02, -SH04, -SH05
22	Base external wiring and piping set	1F-HA02S-01	1 pc.	Pre-installed on the following internal wiring and piping specification. -SH03

No.	Part name	Type	Qty.	Remarks
RV-13FR series				
1	Robot arm	RV-13FR series	Either 1 unit	
2	Installation bolts	M12 x 55	4 pcs.	For robot arm installation
3	Spring washer for installation bolts	For M12	4 pcs.	
4	Plain washer for installation bolts	For M12	4 pcs.	
5	Grease nipple	WA-110	3 pcs.	
		WA-610	4 pcs.	
6	Bulkhead coupling	$\phi 4$	4 pcs.	Supplied for the following internal wiring and piping specification. -SH01
7	Conversion coupling	$\phi 6$ to $\phi 4$	4 pcs.	
8	Air hose for port A	$\phi 4$ x 50mm	2 pcs.	
9	Air hose for port B	$\phi 4$ x 85mm	2 pcs.	
10	Bulkhead coupling	$\phi 4$	2 pcs.	
11	Conversion coupling	$\phi 6$ to $\phi 4$	2 pcs.	Supplied for the following internal wiring and piping specification. -SH04, -SH05
12	Air hose for port A	$\phi 4$ x 50mm	1 pcs.	
13	Air hose for port B	$\phi 4$ x 85mm	1 pcs.	
14	Ferrite core	E04SR301334	1 pc.	
15	Transporting jig		2 sets	Supplied for the following internal wiring and piping specification. -SH02, -SH03, -SH04
16	Transporting jig installation bolt	M10 x 45	4 pcs.	
17	Plain washer for suspension fitting installation bolt	For M10	4 pcs.	
18	Eye bolt	M12	4 pcs.	
19	Nut for eye bolt	For M12	4 pcs.	
20	Fixing plate		1 set	
21	Fixing plate installation bolt	M6 x 14	4 pcs.	
22	Plain washer for fixing plate	For M6	4 pcs.	
23	Base external wiring and piping set	1F-HA01S-01	1 pc.	Pre-installed on the following internal wiring and piping specification. -SH02, -SH04, -SH05
24	Base external wiring and piping set	1F-HA02S-01	1 pc.	Pre-installed on the following internal wiring and piping specification. -SH03

Note 1) RV-4FR/7FR series: Items No. 2 to 12 are contained in the plastic bag in the controller packaging box.
(This is common to the robot alone packaging specifications and the all-in-one packaging specifications.)
Items No. 13 to 22 are mounted on the robot arm.
RV-13FR series: Items No. 2 to 14 are contained in the plastic bag in the controller packaging box.
Items No. 15 to 24 are mounted on the robot arm.

2.2 Installation



Install the robot with a safety fence or enclosure around it. Otherwise, operators may be injured due to unintended access to the robot.

2.2.1 Unpacking

(1) RV-2FR/2FRB

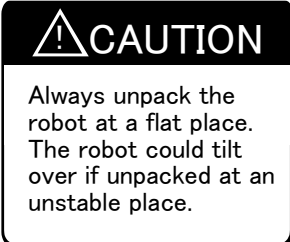
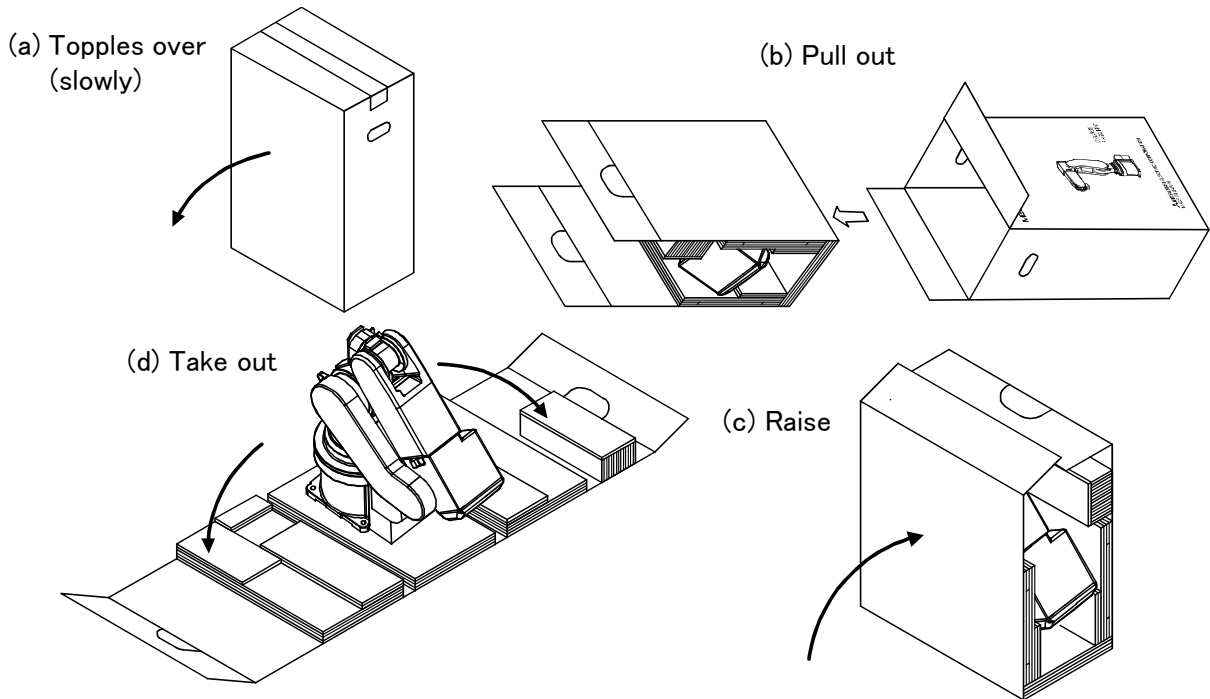

Notes) The packing material is required at re-transportation. Please keep it with care.

Fig.2-1 : Unpacking the robot arm (RV-2FR/2FRB)

The robot is shipped from the factory in cardboard and plywood packing. Always refer to Fig. 2-1 and unpack the robot.

Handle the robot arm according to "2.2.2 Transportation procedures (Transportation by people)".



Always unpack the robot at a flat place. The robot could tilt over if unpacked at an unstable place.

The unpacking process is shown below.

- 1) The cardboard box is toppled over horizontally slowly. Take care so that a shock may not be given (Fig. 2-1 (a))
- 2) Using a knife, etc., slit the tape fixing the upper lid of the cardboard box.
- 3) Pull out inner box horizontally with the handle. (Fig. 2-1 (b))
- 4) Raise the inner box and the robot simultaneously. (Fig. 2-1 (c))
- 5) Remove the robot from the inner box. (Fig. 2-1 (d))

[Note] Do not remove the fixing plate A and B until installation finishes. Always attach the fixing plates while transporting the robot.



When repackaging the robot in the wooden frame, always use the fixing plates.

(2) RV-2FRL/2FRLB

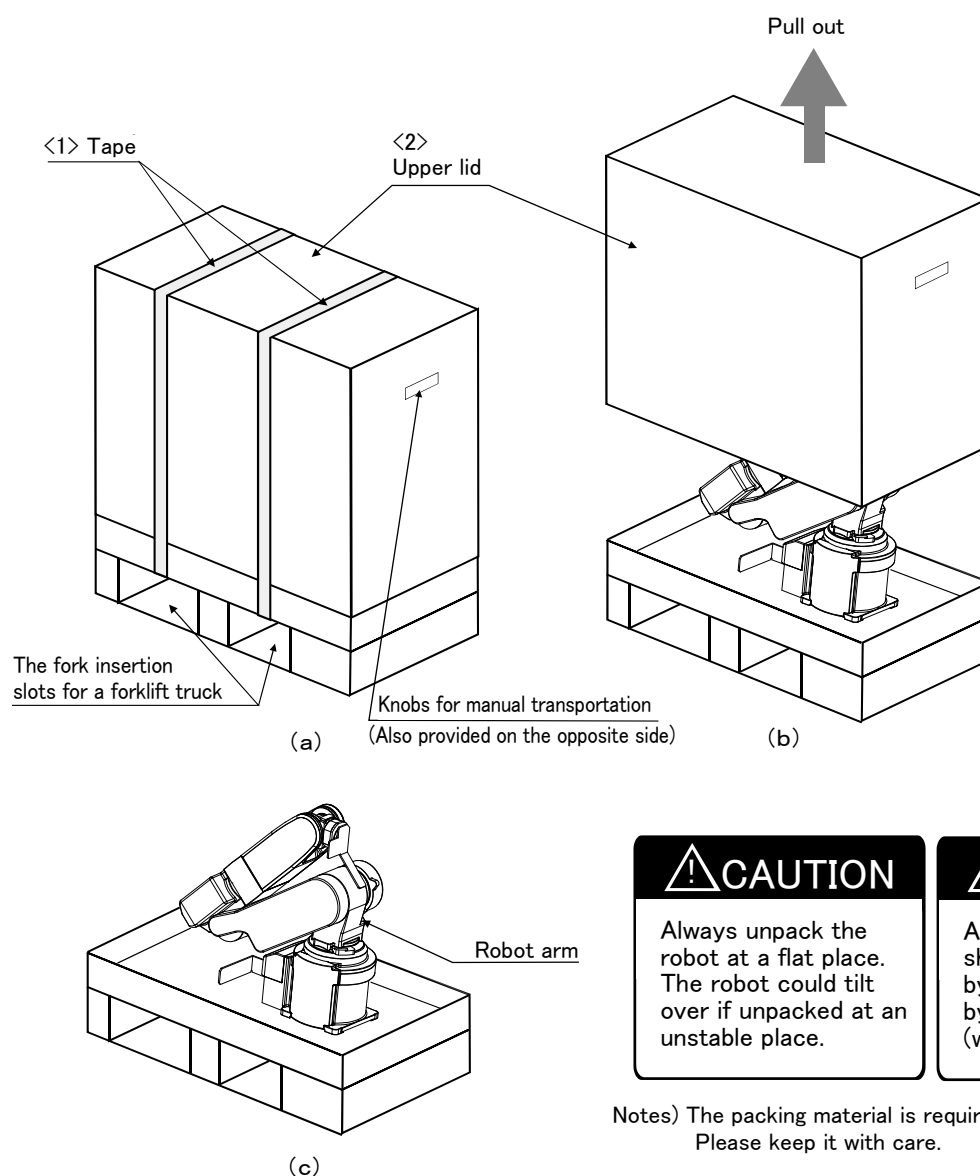
**! CAUTION**

Always unpack the robot at a flat place. The robot could tilt over if unpacked at an unstable place.

! CAUTION

An unopened package shall be transported by a forklift truck or by manually (with two workers).

Notes) The packing material is required at re-transportation. Please keep it with care.

Fig.2-2 : Unpacking the robot arm (RV-2FRL/2FRLB)

The robot is shipped from the factory in cardboard and plywood packing. Always refer to [Fig. 2-2](#) and unpack the robot. Handle the robot arm according to ["2.2.2 Transportation procedures \(Transportation by people\)"](#).

! CAUTION

Always unpack the robot at a flat place. The robot could tilt over if unpacked at an unstable place.

The unpacking process is shown below.

- 1) Using a knife, etc., slit the tape <1> fixing the upper lid <2> of the cardboard box. ([Fig. 2-2 \(a\)](#))
- 2) Pull the upper lid <2> of the cardboard box off with both hands. ([Fig. 2-2 \(b\)](#))
- 3) Remove the hexagon socket bolts <3> (four positions) connecting the sleeper and the base unit. ([Fig. 2-2 \(c\)](#))

[Note] Do not remove the fixing plate A, B, and C until installation finishes. Always attach the fixing plates while transporting the robot.

! CAUTION

When repackaging the robot in the wooden frame, always use the fixing plates.

(3) RV-4FR/7FR series robot alone packaging specifications, RV-13FR series

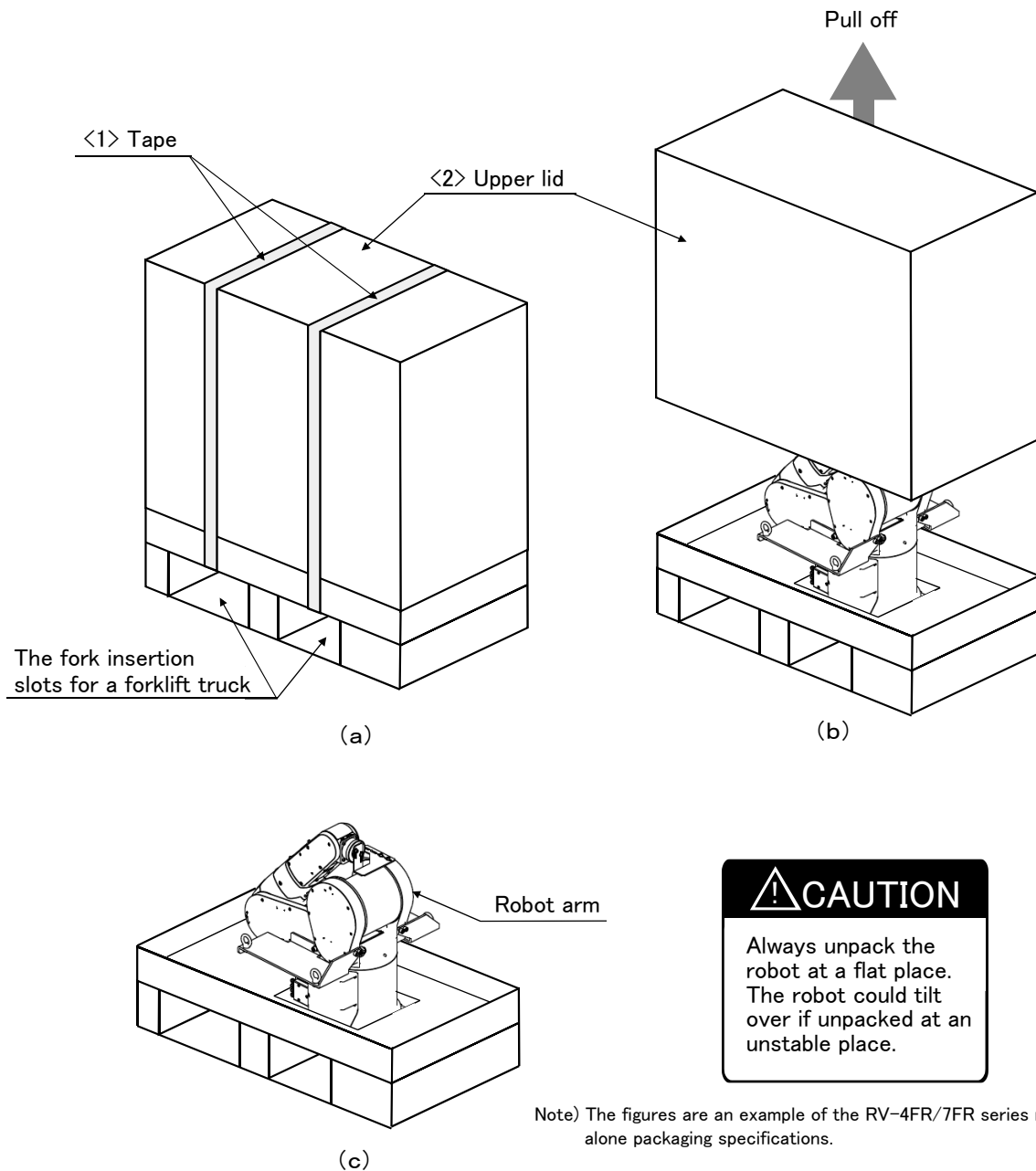

Fig.2-3 : Unpacking of the robot arm (RV-4FR/7FR series robot alone packaging specifications, RV-13FR series)

The robot is shipped from the factory in cardboard and plywood packing. Always refer to Fig. 2-3 and unpack the robot.

Handle the robot arm according to "2.2.3 Transportation procedures (Transporting with a crane)".

CAUTION Always unpack the robot at a flat place. The robot could tilt over if unpacked at an unstable place.

The unpacking process is shown below.

- 1) Using a knife, etc., slit the tape <1> fixing the upper lid <2> of the cardboard box. (Fig. 2-3 (a))
- 2) Pull the upper lid <2> of the cardboard box off with both hands. (Fig. 2-3 (b))
- 3) Remove the hexagon socket bolts <3> (four positions) connecting the sleeper and the base unit. (Fig. 2-3 (c))
- 4) Unpacking is completed.

(4) RV-4FR/7FR series all-in-one packaging specifications

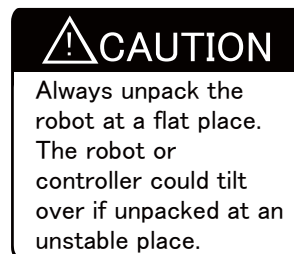
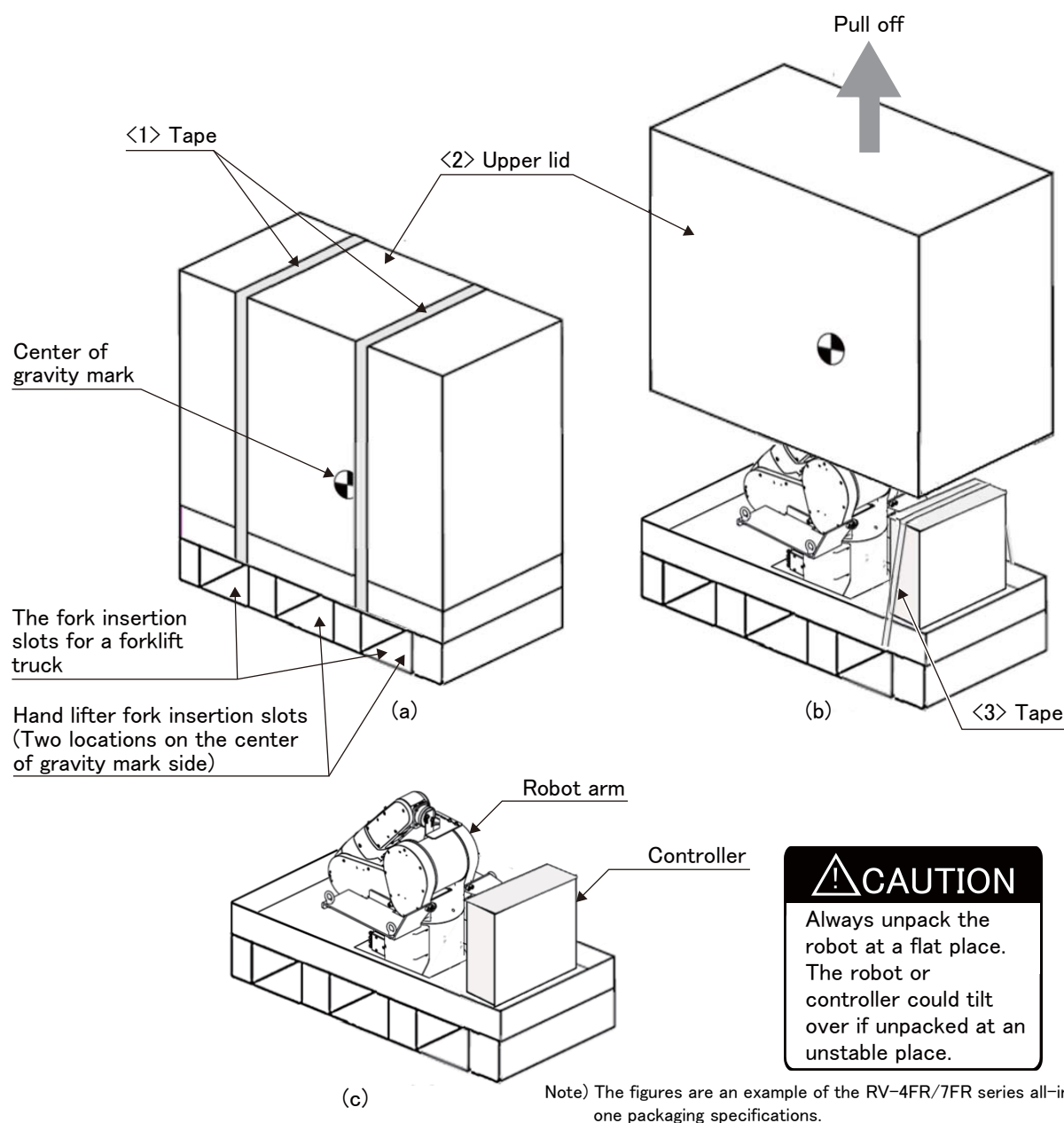

Note) The figures are an example of the RV-4FR/7FR series all-in-one packaging specifications.

Fig.2-4 : Unpacking of the robot arm (RV-4FR/7FR series all-in-one packaging specifications)

The robot is shipped from the factory in cardboard and plywood packing. Always refer to Fig. 2-4 and unpack the robot.

Handle the robot arm according to "2.2.3 Transportation procedures (Transporting with a crane)".



Always unpack the robot at a flat place. The robot or controller could tilt over if unpacked at an unstable place.

The unpacking process is shown below.

- 1) Using a knife, etc., slit the tape <1> fixing the upper lid <2> of the cardboard box. (Fig. 2-4 (a))
- 2) Pull the upper lid <2> of the cardboard box off with both hands, and then cut the tape <3> holding the controller in place with a cutter or similar tool. (Fig. 2-4 (b))
- 3) Take out the controller and remove the four hexagon socket bolts connecting the robot base and the pallet. (Fig. 2-4 (c))
- 4) Unpacking is completed.

2.2.2 Transportation procedures (Transportation by people)

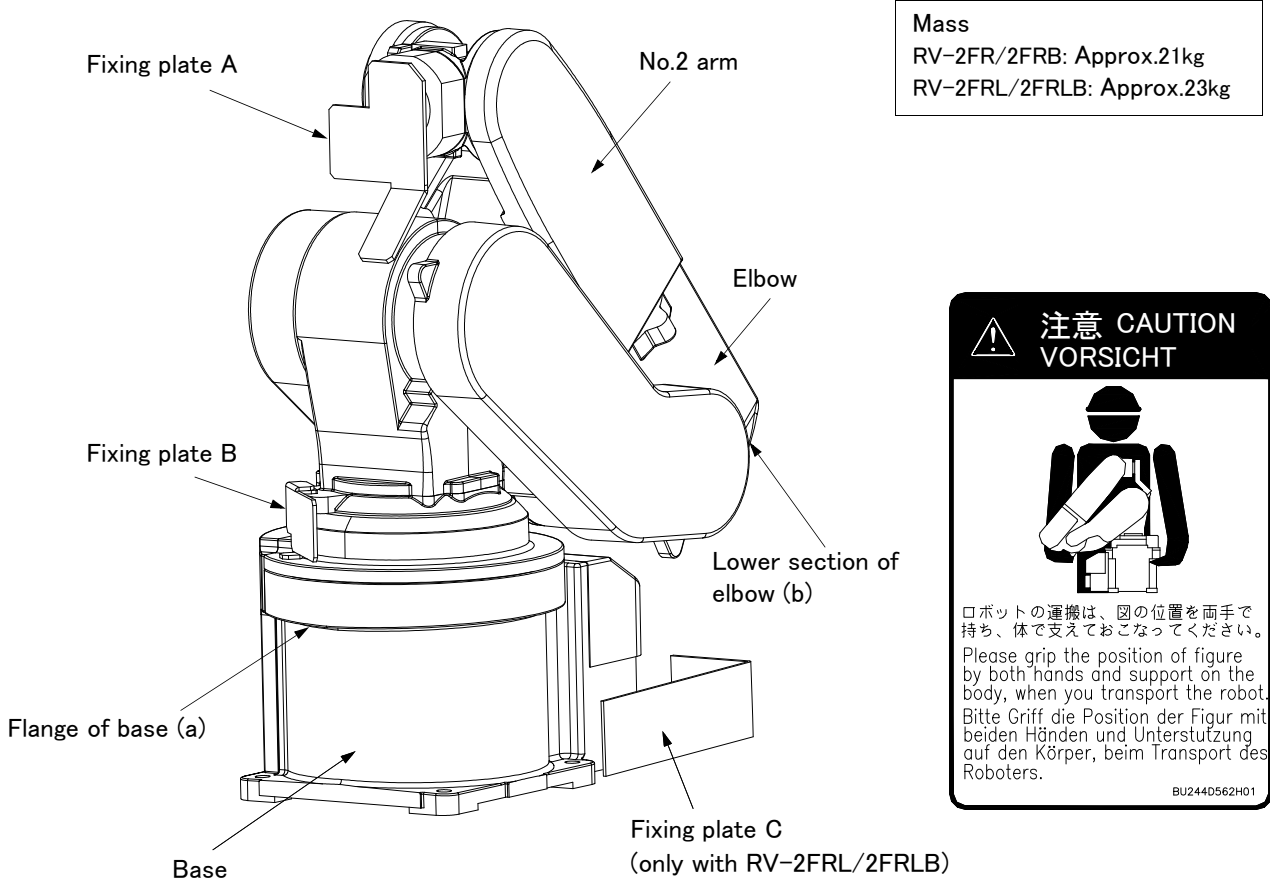

Fig.2-5 : Transportation of robot arm (Transportation by people)

- 1) The robot be transported by one worker. Place the robot on a dolly, etc. and move it to the vicinity of the installation site.
- 2) Raises the robot as supports the robot's left side by your body with having the flange of base (a) and the lower section of elbow (b).
 Please be sure to avoid holding the robot from the front/back side or by the cover because the robot may tilt over and the cover may be damaged or dropped, which may lead to accidents.
- 3) When transporting the robot, do not apply force on the cover, or apply a strong impact on the robot
- 4) Remove the fixing plates after installing the robot.
 In RV-2FRL/2FRLB, reattach two screws (M3) to plug the holes after removing the fixing plate C. Otherwise, a protection specification (IP30) is not satisfied.
- 5) Always attached the fixing plate, and follow the above procedures and methods to transport the robot for secondary transportation, such as when changing the installation position.
 If the arm is directly holded without using the specified fixing plates, or if it is holded in the work posture, the configuration devices could be damaged, and the transportation workers will be subject to risk due to an inadequate center of gravity position.

 **CAUTION**
 **CAUTION**
 **CAUTION**

To prevent accidents, do not hold the robot from the front/back sides, or hold covers that have no grips.

To reattach the fixing plate again, set the axes of the robot to the positions according to [Table 2-2](#).

If it is difficult to follow the transportation procedure shown in this section, take countermeasures not to allow the joints of the robot arm freely move by fixing the robot arm in such a way as to take advantage of the screw holes for fixing plates or the like. Otherwise, applying an excessive power on the joints by external forces may cause a malfunction. Do not apply an excessive load to the robot arm while fixing it. Otherwise, the robot arm may be damaged.

Table 2-2 : Transportation posture (RV-2FR series)

Axis	RV-2FR	RV-2FRL
J1	0°	
J2 ^{Note1)}	-121°	-118°
J3 ^{Note1)}	161°	
J4	0°	
J5	50°	47°
J6	0°	

Note1)The value is a reference value. Release the brake and move the arm until it contact against the mechanical stopper.

2.2.3 Transportation procedures (Transporting with a crane)

The transportation procedure is shown in Fig. 2-6 for (RV-4FR/7FR series) and Fig. 2-7 (RV-13FR series).

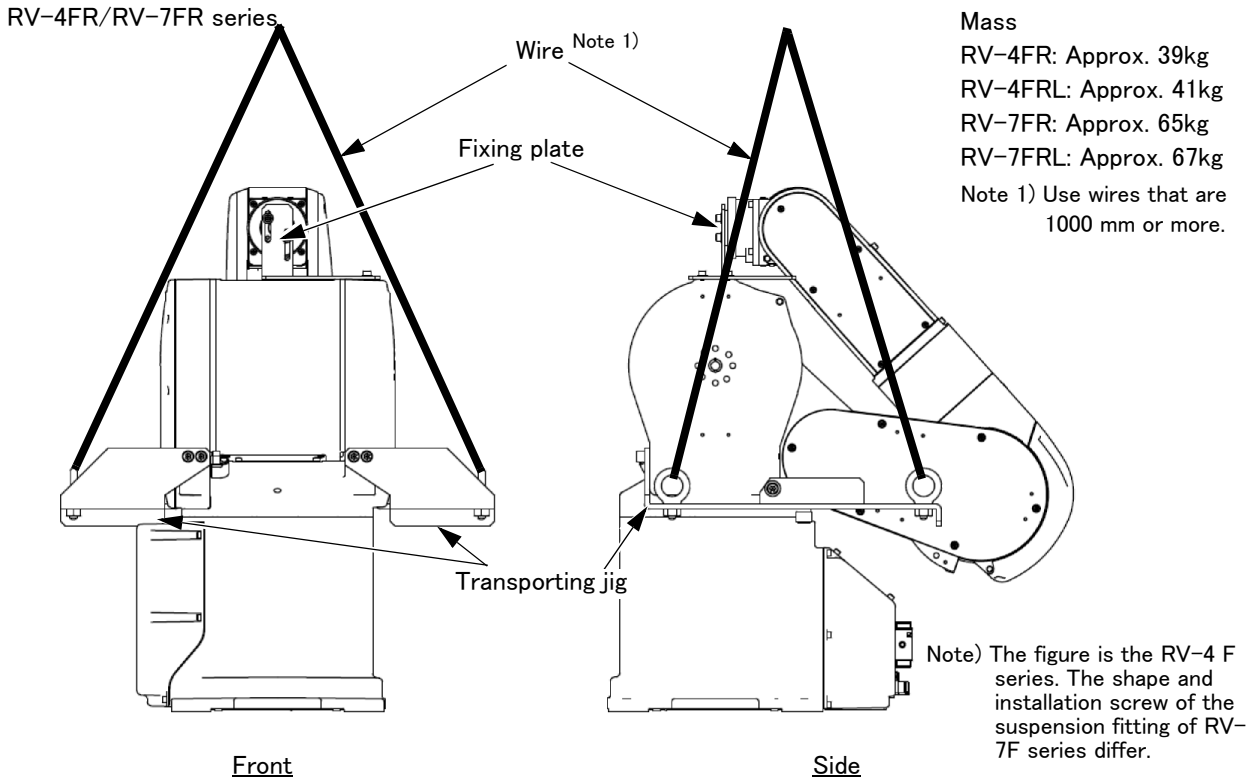

Fig.2-6 : Transportation procedure (transporting with a crane: RV-4FR/7FR series)

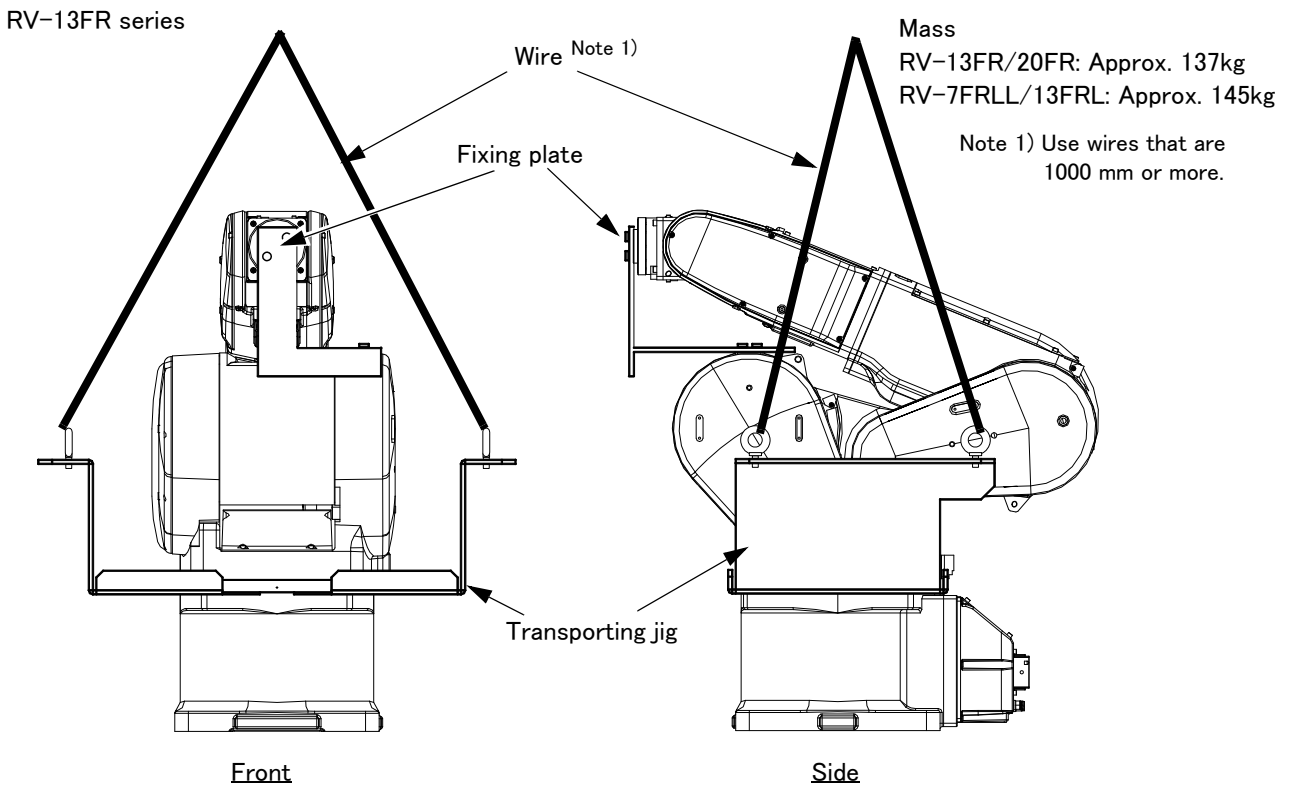

Fig.2-7 : Transportation procedure (transporting with a crane: RV-13FR series)

- 1) Attach the transporting jigs to the left and right sides of the shoulder section, and securely fix with screws and plain washers. (RV-4FR series: M6x20, each three screws for the right and left. RV-7FR series: M8x25, each two screws for the right and left. RV-13FR series: M10x45, each two screws for the right and left.)
(The transporting jigs are mounted on robot arm at factory shipping)
- 2) Catch wires in the eye bolts installed on the transporting jigs, and quietly suspend the arm.
Note) At this time, make sure that the wires, etc., do not interfere with the robot arm or covers. Always place cloth, etc., at interfering places.
- 3) When transferring to the installation place, take care not to apply vibration or impact.
- 4) After installing at the installation place, remove the above transporting jigs.
- 5) Always attached the fixing plate and transporting jigs, and follow the above procedures and methods to transport the robot for secondary transportation, such as when changing the installation position.
If the arm is directly suspended without using the specified transporting jigs, or if it is suspended in the work posture, the configuration devices could be damaged, and the transportation workers will be subject to risk due to an inadequate center of gravity position.

 **CAUTION**

To reattach the fixing plate and transporting jigs again, set the axes of the robot to the positions according to [Table 2-3](#).

 **CAUTION**

If it is difficult to follow the transportation procedure shown in this section, take countermeasures not to allow the joints of the robot arm freely move by fixing the robot arm in such a way as to take advantage of the screw holes for fixing plates or the like. Otherwise, applying an excessive power on the joints by external forces may cause a malfunction.

Do not apply an excessive load to the robot arm while fixing it. Otherwise, the robot arm may be damaged.

Table 2-3 : Transportation posture (RV-4FR/7FR/13FR series)

Axis	RV-4FR	RV-4FRL	RV-7FR	RV-7FRL	RV-7FRLL RV-13FR/13FRL RV-20FR
J1	0°				
J2 ^{Note1)}	-122°	-121°	-116°	-115°	-93°
J3 ^{Note1)}	162°	165°	158°	164°	160°
J4	0°				
J5	45°	41°	48°	41°	23°
J6	0°				

Note1)The value is a reference value. Release the brake and move the arm until it contact against the mechanical stopper.

2.2.4 Installation procedures

The installation procedure of the robot arm is shown below.

Installation bolt

RV-2FR series: 4-M8 × 35

RV-4FR/7FR series: 4-M8 × 40

RV-13FR series: 4-M12 × 55

Spring washer

Plain washer

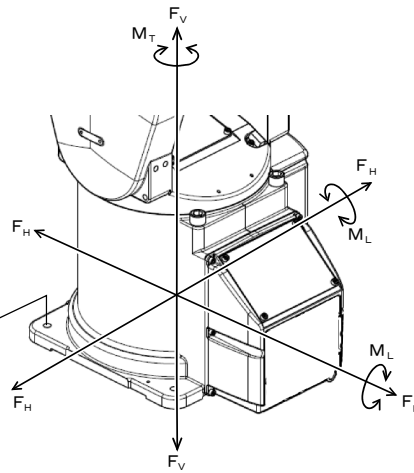

<Bottom view>

RV-2FR series

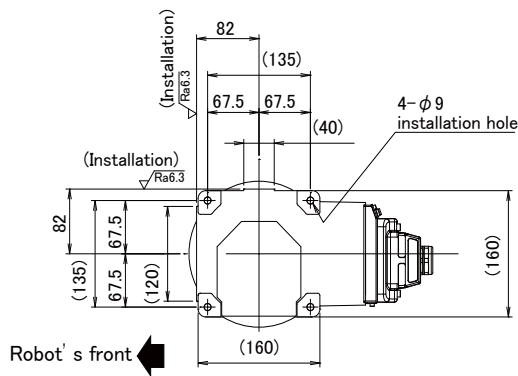

RV-4FR series

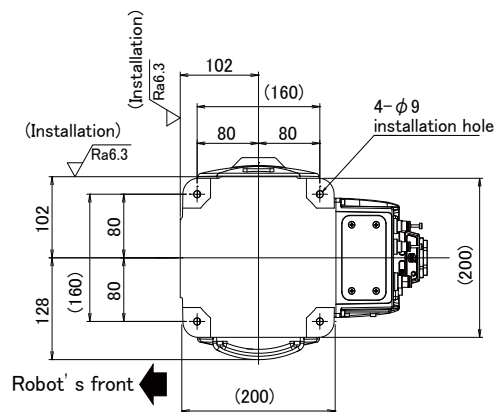

RV-7FR series

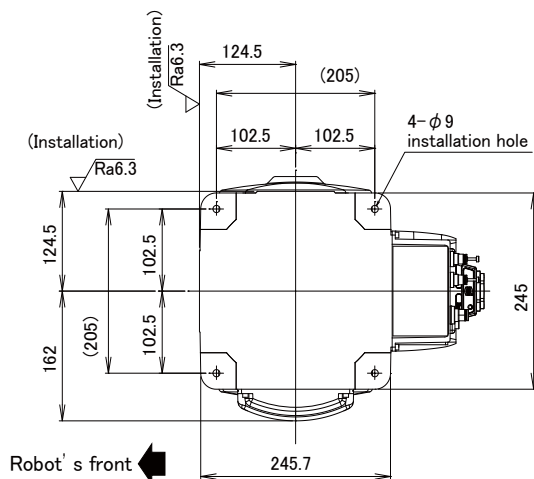

RV-13FR series

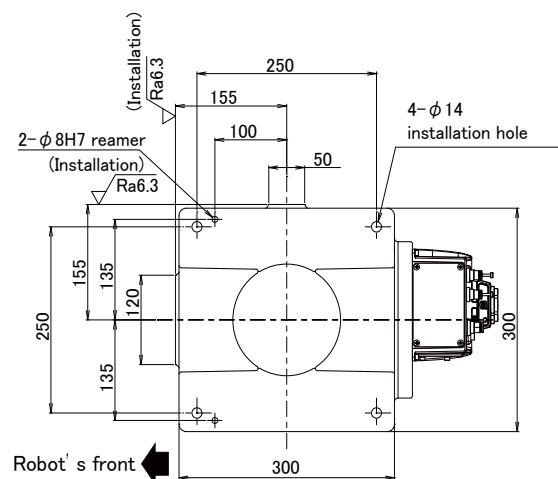

Fig.2-8 : Installation dimensions

- 1) The robot installation surface has been machine finished. Use the installation holes opened at the four corners of the base, and securely fix the robot with the enclosed installation bolts.

Model	Installation hole size	Installation bolt (attachment)	Recommended tightening torque
RV-2FR/2FRL, RV-2FRB/2FRBL, RV-4FR/4FRL, RV-7FR/7FRL	4- ϕ 9	M8 hexagon socket head cap screw	26.5N · m
RV-7FRLL, RV-13FR/13FRL, RV-20FR	4- ϕ 14	M12 hexagon socket head cap screw	92.1N · m

- 2) Install the robot on a level surface.
- 3) It is recommended that the surface roughness of the table onto which the robot is to be installed by 6.3 Ra or more. If the installation surface is rough, the contact with the table will be poor, and positional deviation could occur when the robot moves.
- 4) When installing, use a common table to prevent the position of the devices and jigs subject to robot work from deviating.
- 5) The installation surface must have sufficient strength to withstand the arm reaction during operation, and resistance against deformation and vibration caused by the static (dynamic) load of the robot arm and peripheral devices, etc.
- 6) Remove the fixing plates and suspension fittings after installing the robot. The plates and fittings are needed in re-transportation. Please keep it carefully.
- 7) When the robot is installed by hanging from the ceiling or on the wall, the MEGDIR parameter must be changed. For more information about parameters and how to change the parameters, refer to the separate "Instruction Manual/Detailed Explanation of Functions and Operations".
- 8) The installation surface must have sufficient strength to withstand the arm reaction during moving the robot at high speed.

Table 2-4 : Strength of the installation side (reference)

Item	Unit	Value
RH-2FR series		
Tilt moment : M_L	N · m	240
Torsional moment : M_T	N · m	150
Horizontal direction translation force : F_H	N	700
Vertical direction translation force : F_V	N	820
RH-4FR series		
Tilt moment : M_L	N · m	410
Torsional moment : M_T	N · m	400
Horizontal direction translation force : F_H	N	700
Vertical direction translation force : F_V	N	1,200
RH-7FR series		
Tilt moment : M_L	N · m	900
Torsional moment : M_T	N · m	900
Horizontal direction translation force : F_H	N	1,000
Vertical direction translation force : F_V	N	1,700
RH-7FRLL, RV-13FR/13FRL, RV-20FR		
Tilt moment : M_L	N · m	2,060
Torsional moment : M_T	N · m	2,060
Horizontal direction translation force : F_H	N	1,750
Vertical direction translation force : F_V	N	2,900

 **CAUTION**

Please secure the maintenance space required for connection of the machine cable and exchange the backup battery in the rear side, and also space for J1 axis belt in the right side. And don't install the robot arm in the position where direct rays or the heat of lighting hits. The skin temperature of the robot arm may rise, and the error may occur.

2.2.5 Grounding procedures

(1) Grounding methods

- 1) There are three grounding methods as shown in Fig. 2-9, but the dedicated grounding (Fig. 2-9 (a)) should be used for the robot arm and controller when possible. (Refer to the separate "Controller Setup, Basic Operation and Maintenance" for details on the controller grounding.)
- 2) Use Class D grounding (grounding resistance $100\ \Omega$ or less). Dedicated grounding separated from the other devices should be used.
- 3) Use a AWG#11(4.2mm^2) or more stranded wire for the grounding wire. The grounding point should be as close to the robot arm and controller as possible, and the length of the grounding wire should be short.

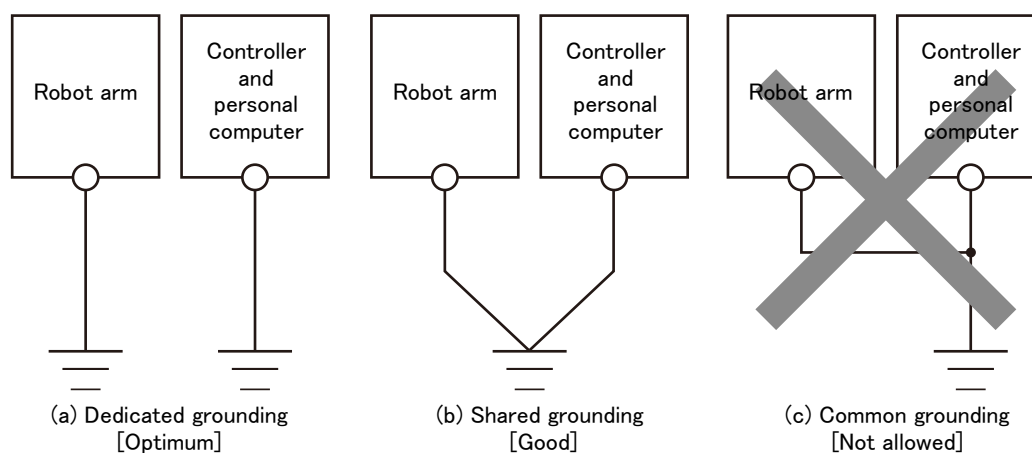

Fig.2-9 : Grounding methods

(2) Grounding procedures

- 1) Prepare the grounding cable (AWG#11 (4.2mm^2) or more) and robot side installation screw and washer.
- 2) If there is rust or paint on the grounding screw section (A), remove it with a file, etc.
- 3) Connect the grounding cable to the grounding screw section.

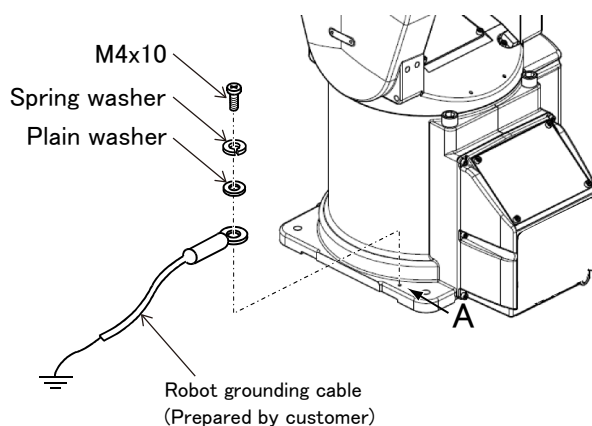

Fig.2-10 : Connecting the grounding cable

Note) Although the figure is the example of RV-4FR other types are the same also.

2.2.6 Connecting with the controller

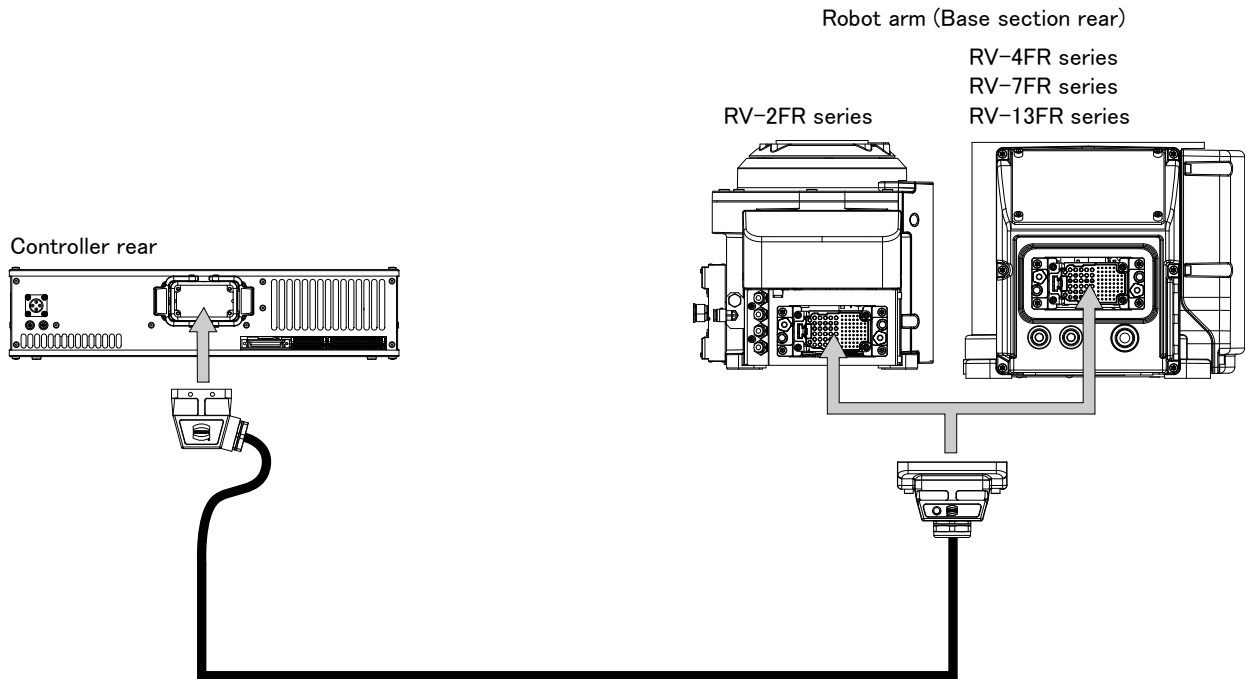

Fig.2-11 : Connecting the machine cables

Carry out the following procedure after installing the controller referring to the separate "Controller Setup, Basic Operation and Maintenance" manual.

(1) Connection of robot arm and machine cable



1) Make sure that the power of the controller is turned OFF.

2) Connect the machine cable to CN1 connector on the robot arm.

Note) RV-7FR series is shown. The same connection method is also applicable to other models with the same-shaped connector.

For RV-2FR series, insert the connector until the connector edge is aligned with the CONBOX surface and tighten two bolts.

For RV-4FR/7FR series, insert the connector until the line of the connector is aligned with the CONBOX surface and tighten two bolts.

(Screw fixing torque: 3.6 to 4.4 Nm)

CAUTION Be careful not to get your hand pinched.

Connecting the machine cable is completed.



CAUTION

When installing or removing the connector, to the connector of the other party in parallel, install or remove.

If load strong against one side is applied, the connector pin may be damaged and it may not be connected securely.



CAUTION

The machine cable connectors are dedicated for the controller side and robot arm side, so take special care when connecting.

If connected incorrectly, the connector pins could bend or break. Thus, even if connected correctly, the robot will not operate correctly, creating a dangerous situation.



CAUTION

Take special care to the leading of the connection cable. If the cable is pulled with force or bent excessively, wires could break or the connector could be damaged.



CAUTION

Connect the machine cable at the place without the effect of the dust or oil mist. Please keep the dust and oil mist from being applied to of the robot arm connector section, in the condition that the machine cable is removed. Since it becomes the cause of failure.

Before disconnecting the machine cable, wipe off dust and oil mist around the connector.



CAUTION

Please be careful not to catch the hand at installation and removal.

To disconnect the machine cable, hold the connector part and pull out the cable. Pulling the cable part may cause the cable to come off or break.

(2) Connection of controller and machine cable

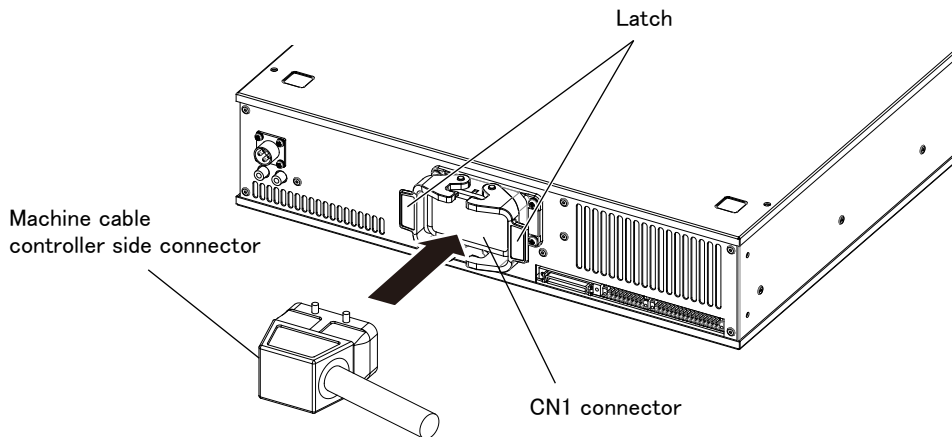

Fig.2-12 : Connecting with the controller

- 1) Make sure that the power of the controller is turned OFF.
- 2) Connect the controller side connector of the machine cable to CN1 connector on the rear side of the controller.
- 3) To fix the inserted connector, close the latches of the CN1 connector.

CAUTION When connecting and disconnecting the connector, be careful not to get your hand pinched.

CAUTION When installing or removing the connector, to the connector of the other party in parallel, install or remove.
If load strong against one side is applied, the connector pin may be damaged and it may not be connected securely.

CAUTION To disconnect the cable, open the latches, hold the connector part, and pull out the cable. Pulling the cable part may cause the cable to come off or break.

CAUTION The machine cable connectors are dedicated for the controller side and robot arm side, so take special care when connecting.
If connected incorrectly, the connector pins could bend or break. Thus, even if connected correctly, the robot will not operate correctly, creating a dangerous situation.

CAUTION Take special care to the leading of the connection cable. If the cable is pulled with force or bent excessively, wires could break or the connector could be damaged.

CAUTION Connect the machine cable at the place without the effect of the dust or oil mist. Please keep the dust and oil mist from being applied to of the robot arm connector section, in the condition that the machine cable is removed. Since it becomes the cause of failure.

2.2.7 About oil mist specification

(1) Piping for pressurization inside robot arm

In use in oil mist environment, please connect the $\phi 8$ air hose to the coupling for pressurization of the robot arm base portion "AIR PURGE", and pressurize the inside of the robot arm.

Refer to the separate "Standard specifications manual" for specification of air purge.

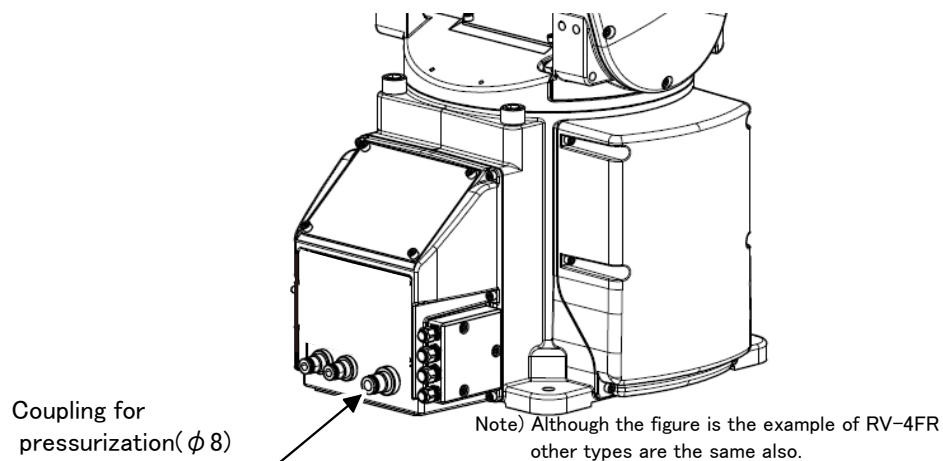

Fig.2-13 : Air purge

2.2.8 About clean specification

(1) Piping for suction inside robot arm

In use of the robot of clean specification, please connect the $\phi 8$ air hose to the coupling for suction of the robot body base portion "VACUUM", and suck the inside of the robot arm.

Refer to the separate "Standard specifications manual" for vacuum condition.

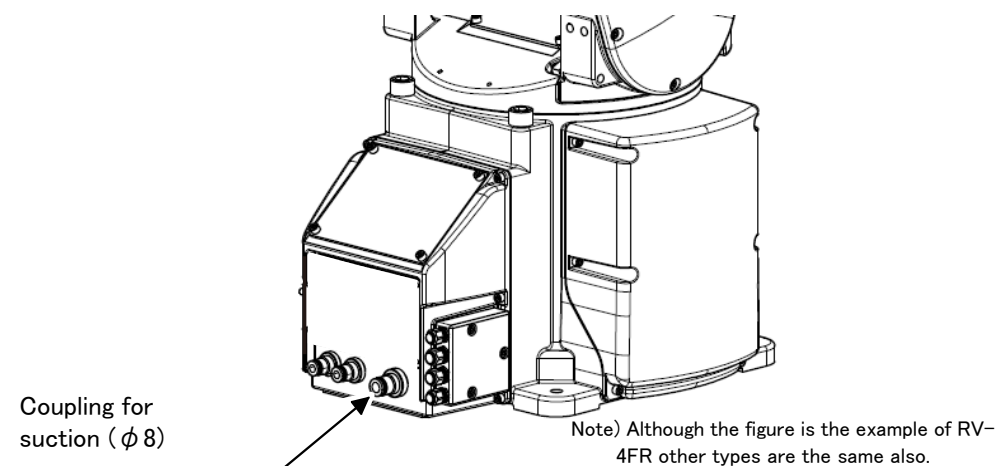

Fig.2-14 : Vacuum

2.3 Confirming the operation

After the robot is connected to the controller, the origin data is automatically written.

Then, manually move the robot using the T/B to confirm that the operation is correct.

Moving the robot manually is called "jog operation". This operation includes the JOINT jog that moves each axis, the XYZ jog that moves along the base coordinate system, the TOOL jog that moves along the tool coordinate system, the Work jog that moves along the work coordinate system, and the CYLINDER jog that moves along the circular arc.

This operation is carried out while pressing the deadman switch on the back of the T/B.

Note) The figure of the robot which indicated to the explanation page in each jog mode is an example.



CAUTION

The robot will move during this operation. Make sure that there are no operators near the robot, and that there are no obstacles, such as tools, in the robot operation range.



CAUTION

To immediately stop the robot, release the deadman switch on the back of the T/B. The servo power will turn OFF, and the robot will stop. The robot will also stop if the [EMG.STOP] switch (emergency stop switch) on the front of the T/B is pressed.



CAUTION

To check whether the origin of the robot deviates, move the robot arm to the position where the ABS marks align each other, and check the displayed joint coordinates of the position.

For the details of the ABS mark position and the joint coordinates, refer to [Page 155, "5.6 Resetting the origin"](#).

2.3.1 Installing the teaching pendant (T/B)

Installing the T/B, with turning off the controller power.

CAUTION Please do not pull the cable of T/B strongly or do not bend it too much. It becomes the breaking of a wire of the cable and the cause of breakage of the connector. Please installing so that stress does not start the cable with the connector itself.

Explain the installation method of T/B below.

- 1) Check that the controller's power supply is OFF.
- 2) Refer to Fig. 2-15 and connect T/B connector to the robot controller.
Use as the upper surface the lock lever, and push in until there is sound.
- 3) Pressing down the lock lever to lock the connector as shown below.

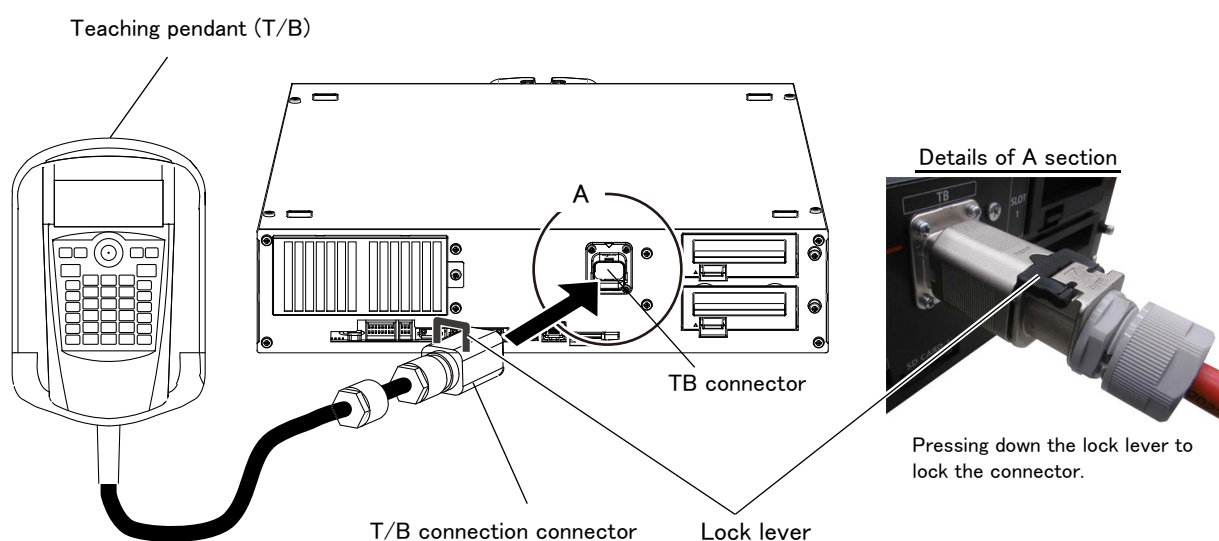

Fig. 2-15 : Installing the T/B

2.3.2 Turning ON the control power

CAUTION Confirm that there are no operators near the robot before turning the power ON.

- 1) Turn the controller power switch ON.
Turns ON the switch of the earth leakage breaker of installation outside.

* Controller software version C2d or later

If the hand conditions (weight, size, and center of gravity) have not been set, error C0330 (Undefined hand condition) will occur upon power on.

Clear the error from the teaching pendant or RT ToolBox3 until the hand conditions are set.

Set the hand conditions using the parameter HNDDAT* (* = 0 to 8).

For further information, refer to "Movement parameter" in the "Instruction Manual/Detailed explanations of functions and operations".

2.3.3 Preparing the T/B

Next, prepare to use the T/B

1) Set the mode of the controller to "MANUAL".

2) Set the T/B [ENABLE] switch to "ENABLE". The menu selection screen will appear.

The following operations are carried out with the T/B.

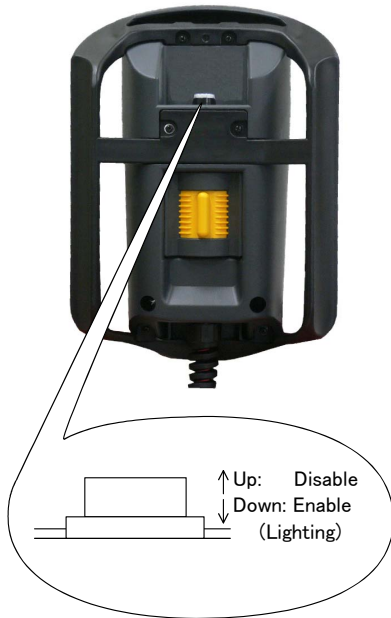

◆◆◆ Operating from the T/B ◆◆◆

Always set the mode of the controller to "MAMNUAL", and then set the T/B [ENABLE] switch to "ENABLE". When the T/B is valid, only operations from the T/B are possible. Operations from the external signals will not be accepted. The stop-related operations such as an emergency stop can be performed regardless of the valid/invalid setting.

◆◆◆ How to choose the jog mode ◆◆◆

<CURRENT>	JOINT	100%	M1	TO	B1
J1:	+0.00	J5:	+0.00		
J2:	+0.00	J6:	+0.00		
J3:	+90.00	:	:		
J4:	+0.00	:	:		

XYZ	TOOL	JOG	3-XYZ	CYLNR	⇒
-----	------	-----	-------	-------	---

Choose the jog mode

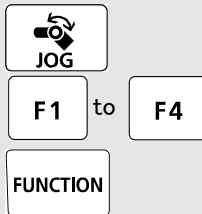

Press the [JOG] key, the jog screen will be displayed, and display the jog mode which can be chosen at the bottom of the screen. Because these correspond to the function key of [F1] – [F4], press the function key corresponding to the jog mode to wish. And, if the [FUNCTION] key is pressed, selection in jog modes other than the present display is possible. The override (100%), the mechanism number (M1), and the tool number (T0), and the base coordinate number (B1) are displayed on the upside of the screen following the present jog mode (JOINT).

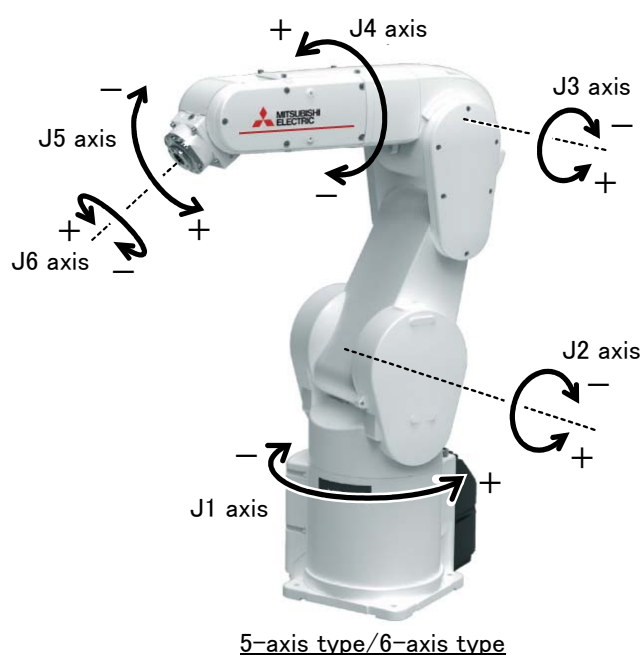

* Each axis moves independently. The 5-axis type robot has no J4 axis.

Fig.2-16 : JOINT jog operation

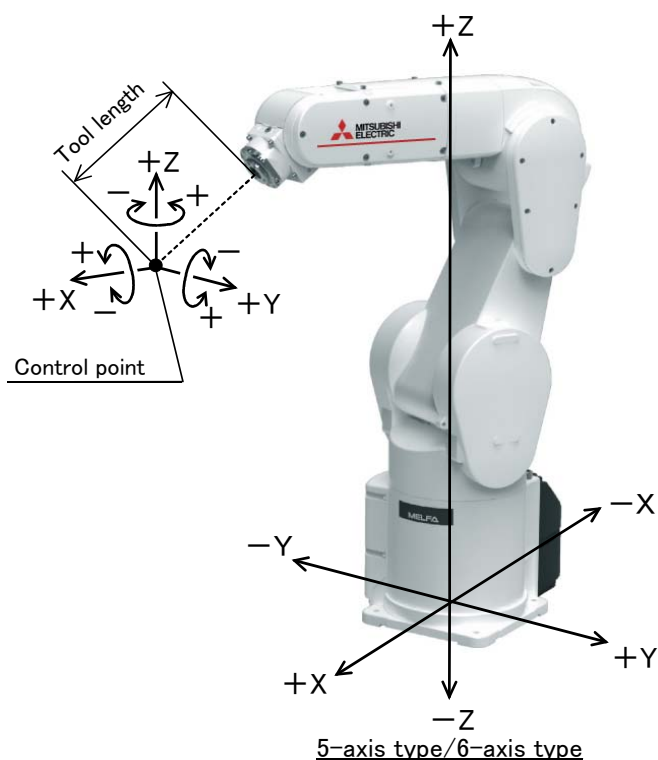

* While maintaining the flange surface posture, the axis moves straight along the base coordinate system.
The 6-axis type robot maintains the flange surface posture.
Also, while maintaining the flange surface position, the flange surface posture changes.

Fig.2-17 : XYZ jog operation

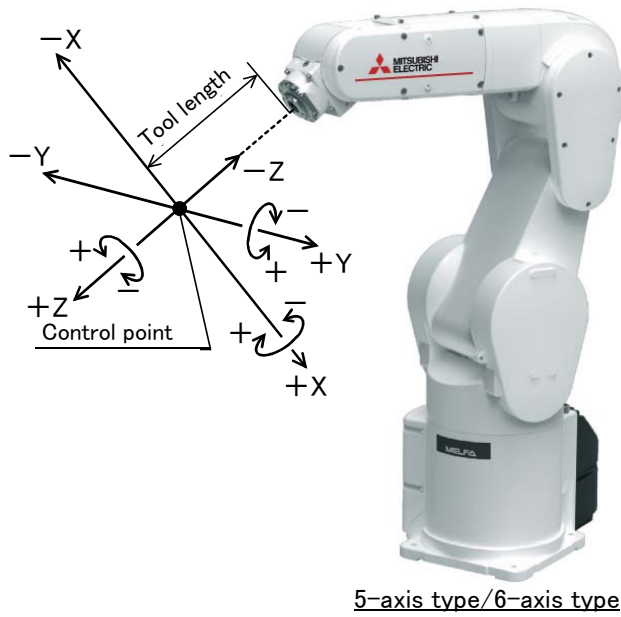

5-axis type/6-axis type

* While maintaining the flange surface posture, the axis moves straight along the tool coordinate system. Also, while maintaining the flange surface position, the flange surface posture changes. For the 5-axis type robot, the axis moves only in the X and Z axis directions of tool coordinate system.

Fig.2-18 : TOOL jog operation

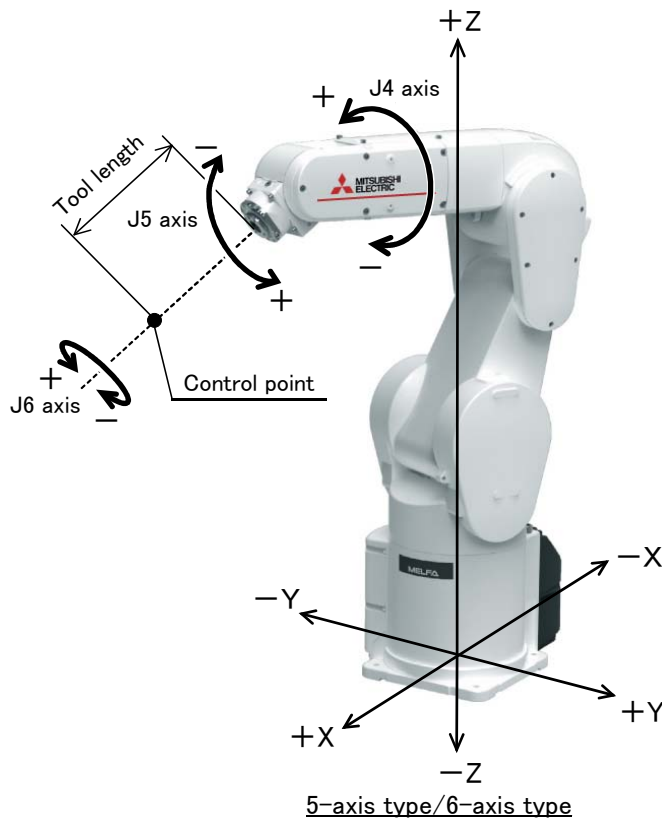

5-axis type/6-axis type

* The axis moves straight along the base coordinate system. At this time, the flange surface posture is not maintained. Also, the flange surface posture changes. The flange surface position does not change at this time. It is effective to change the posture of the wrist, with the position maintained. The 5-axis type robot has no J4 axis.

Fig.2-19 : 3-axis XYZ jog operation

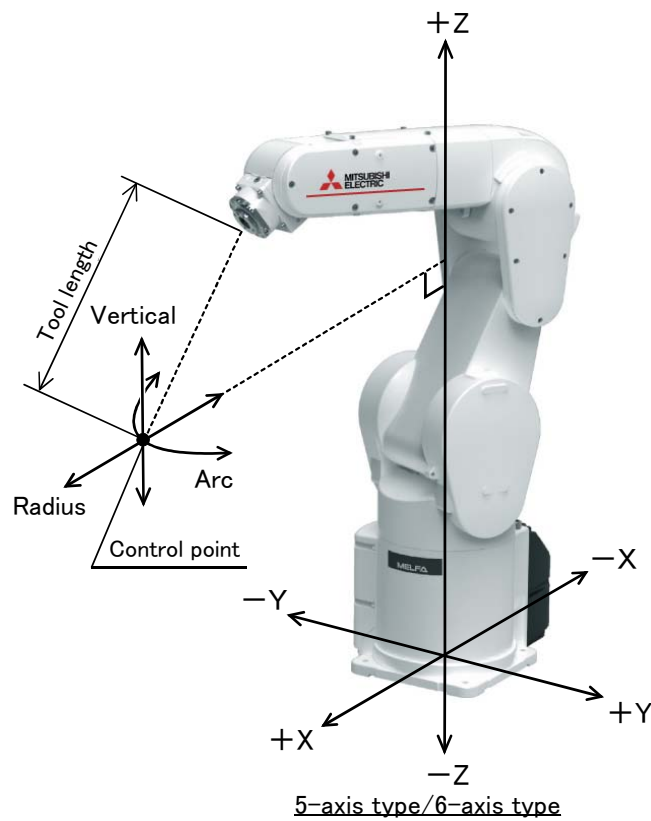

* The current position is set as the arc centering on the Z axis, and the axis moves along that arc, expands and contracts in the radius direction, and moves vertically. At this time, the flange surface posture is maintained. Also, while maintaining the flange surface position, the flange surface posture changes.

Fig.2-20 : CYLINDER jog operation

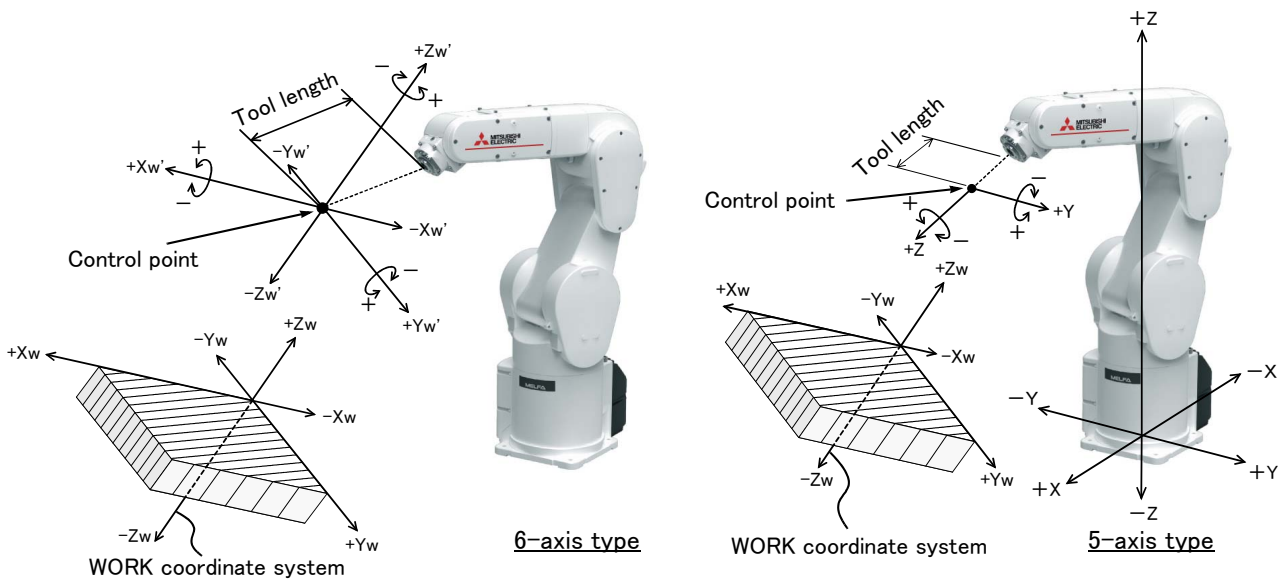

* While maintaining the flange surface posture, the axis moves straight along the work coordinate system. Also, while maintaining the flange surface position, the flange surface posture changes.

* Jog operation around the work coordinates system is available for the 6-axis type (EX-T jog). In this jog operation, when the jog operation is performed for the posture elements, the posture rotates on the Xw axis, Yw axis, or Zw axis of the work coordinates system while the control point is changed.

Fig.2-21 : WORK jog operation

(1) JOINT jog operation

Select joint jog mode

<CURRENT>	JOINT	100%	M1	TO
J1:	+0.00	J5:	+0.00	
J2:	+0.00	J6:	+0.00	
J3:	+90.00	:		
J4:	+0.00	:		

XYZ TOOL JOG 3-XYZ CYLNR =>

Joint jog mode

JOG F1

Set jog speed

<CURRENT>	JOINT	100%	M1	TO
J1:	+0.00	J5:	+0.00	
J2:	+0.00	J6:	+0.00	
J3:	+90.00	:		
J4:	+0.00	:		

XYZ TOOL JOG 3-XYZ CYLNR =>

Setting the speed

OVRD ↑ OVRD ↓

[JOG] Press the key and display the jog screen. ("JOG" is displayed on the screen bottom)

Check that the "joint" in jog mode is displayed on the screen.

If other jog modes are displayed, please press the function key corresponding to the "joint." (If the jog mode which he wishes under the screen is not displayed, it is displayed that the [FUNCTION] key is pressed)

If it finishes jog operation, press the [JOG] key again, or function key which correspond to "close."

Whenever it presses the key of [OVRD ↑], the override goes up. Conversely, if the [OVRD ↓] key is pressed, it will go down.

The current setting speed is displayed on screen upper right. Set the override to 10% here for confirmation work.

J1 axis jog operation

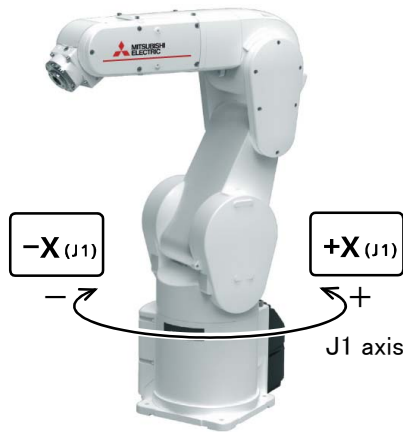

5-axis type/6-axis type

- When the [+X (J1)] keys are pressed, the J1 axis will rotate in the plus direction. When the [-X (J1)] keys are pressed, rotate in the minus direction.

J2 axis jog operation

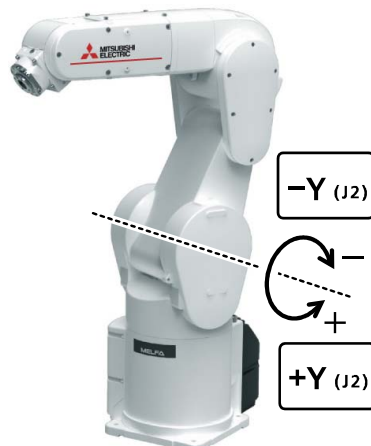

5-axis type/6-axis type

- When the [+Y (J2)] keys are pressed, the J2 axis will rotate in the plus direction. When the [-Y (J2)] keys are pressed, rotate in the minus direction.

◇◆◇ When the robot is in the transportation posture ◇◆◇

The axes may be outside the movement area. Move these axes toward the inner side of the movement area.

J3 axis jog operation

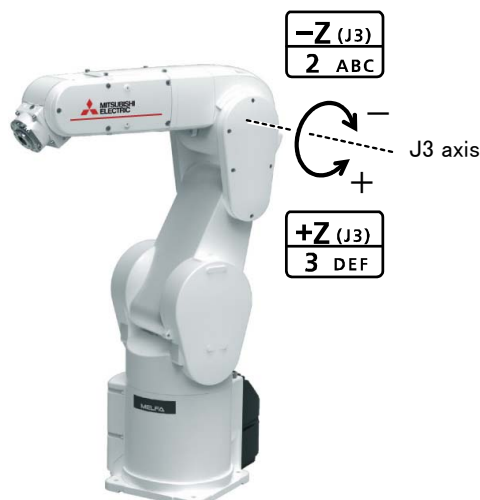

5-axis type/6-axis type

- When the [+Z (J3)] keys are pressed, the J3 axis will rotate in the plus direction.
When the [-Z (J3)] keys are pressed, rotate in the minus direction.

J4, J5 and J6 axis jog operation

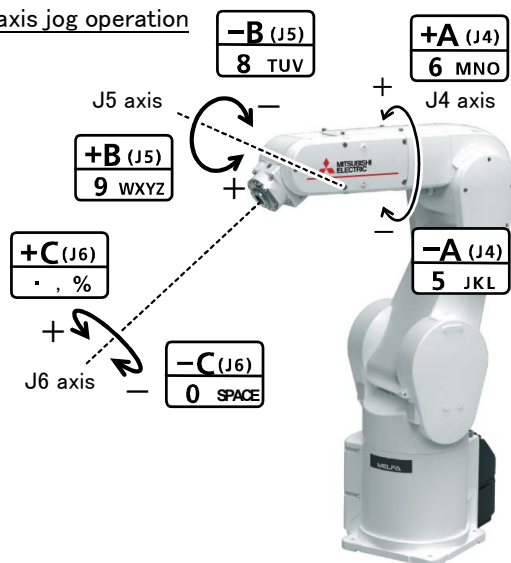

* The 5-axis type robot has no J4 axis.

5-axis type/6-axis type

- When the [+A (J4)] keys are pressed, the J4 axis will rotate in the plus direction. (6-axis type only)
When the [-A (J4)] keys are pressed, rotate in the minus direction. (6-axis type only)
- When the [+B (J5)] keys are pressed, the J5 axis will rotate in the plus direction
When the [-B (J5)] keys are pressed, rotate in the minus direction.
- When the [+C (J6)] keys are pressed, the J6 axis will rotate in the plus direction
When the [-C (J6)] keys are pressed, rotate in the minus direction.

◇◆◇ If the buzzer of T/B sounds and the robot does not move ◇◆◇

If it is going to move the robot across the operation range, the buzzer of T/B sounds and the robot does not move. In this case, please move to the counter direction.

(2) XYZ jog operation

Select XYZ jog mode

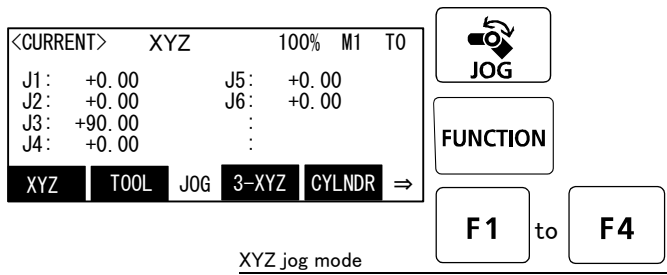

Set jog speed

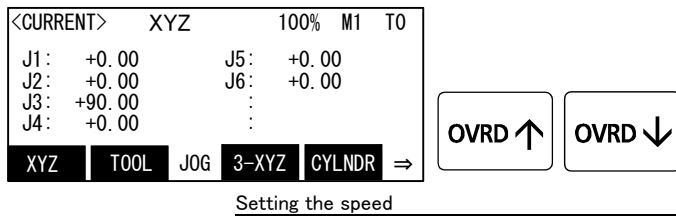

[JOG] Press the key and display the jog screen. ("JOG" is displayed on the screen bottom)

Check that the "XYZ" in jog mode is displayed on the screen.

If other jog modes are displayed, please press the function key corresponding to the "XYZ." (If the jog mode which he wishes under the screen is not displayed, it is displayed that the [FUNCTION] key is pressed)

If it finishes jog operation, press the [JOG] key again, or function key which correspond to "close."

Whenever it presses the key of [OVRD ↑], the override goes up. Conversely, if the [OVRD ↓] key is pressed, it will go down.

The current setting speed is displayed on screen upper right. Set the override to 10% here for confirmation work.

Moving along the base coordinate system

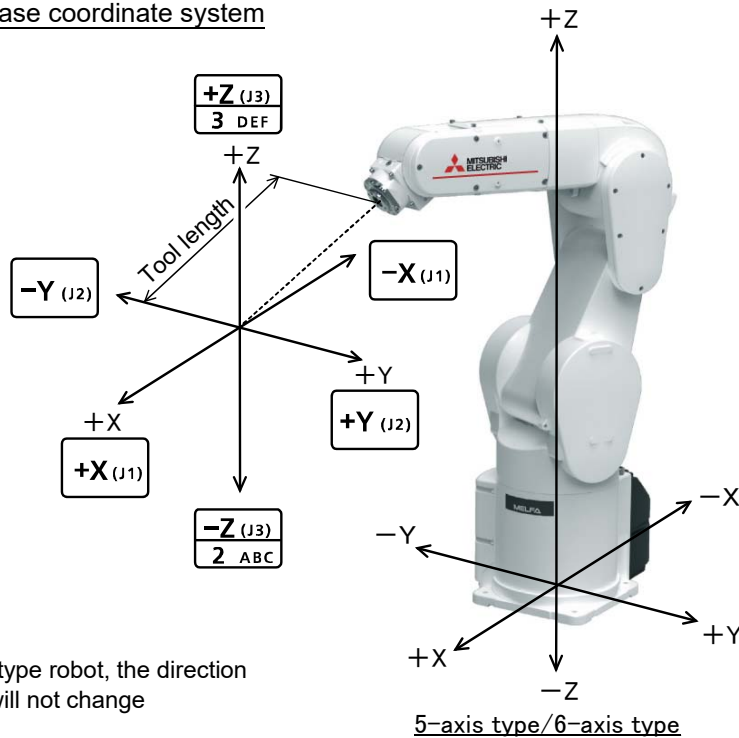

* For the 6-axis type robot, the direction of the flange will not change

- When the [+X (J1)] keys are pressed, the robot will move along the X axis plus direction. When the [-X (J1)] keys are pressed, move along the minus direction.
- When the [+Y (J2)] keys are pressed, the robot will move along the Y axis plus direction. When the [-Y (J2)] keys are pressed, move along the minus direction.
- When the [+Z (J3)] keys are pressed, the robot will move along the Z axis plus direction. When the [-Z (J3)] keys are pressed, move along the minus direction.

◆◆◆ When the robot is in the transportation posture ◆◆◆

There are directions from which linear movement is not possible from the transportation posture. In this case, the robot will not move. Refer to section [Page 32, "\(1\) JOINT jog operation"](#), and move the robot to a position where linear movement is possible, and then carry out XYZ jog.

◆◆◆ If the buzzer of T/B sounds and the robot does not move ◆◆◆

If it is going to move the robot across the operation range, the buzzer of T/B sounds and the robot does not move. In this case, please move to the counter direction.

Changing the flange surface posture

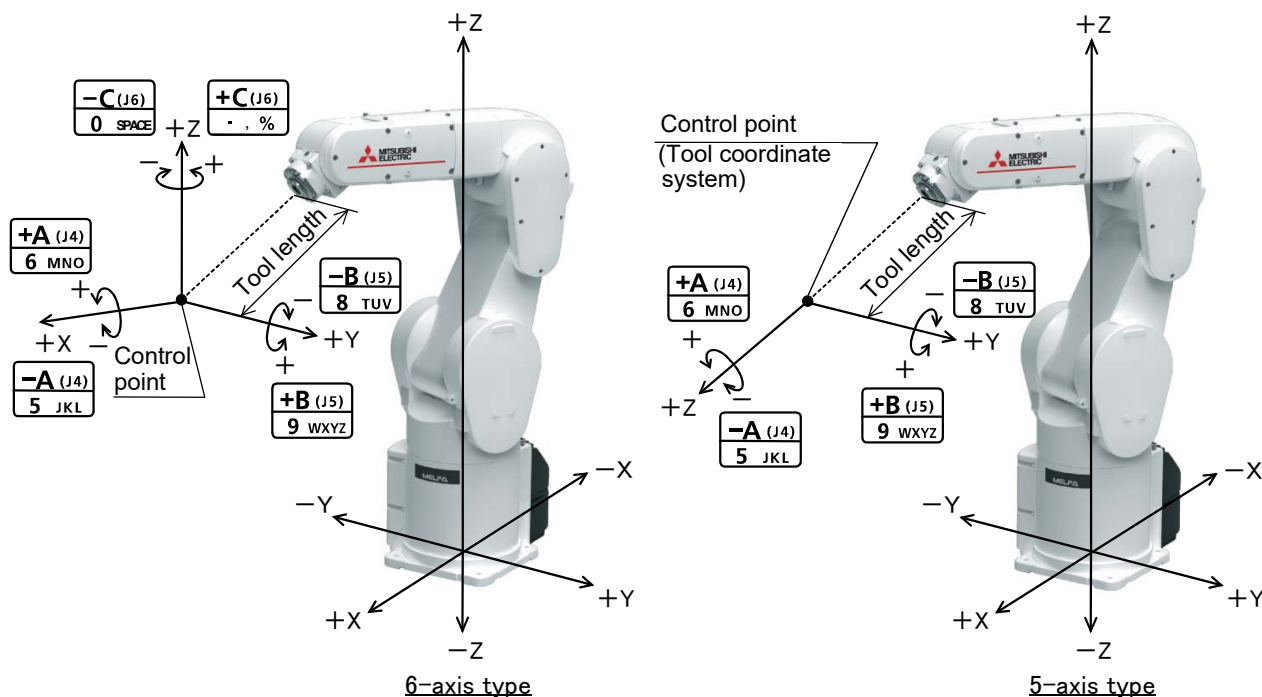

* The control point does not change.

- When the [+A (J4)] keys are pressed,
 - 6-axis type: the X axis will rotate in the plus direction.
 - 5-axis type: the Z axis will rotate in the plus direction of the tool coordinate system.
- When the [-A (J4)] keys are pressed, rotate in the minus direction.
- When the [+B (J5)] keys are pressed,
 - 6-axis type: the Y axis will rotate in the plus direction.
 - 5-axis type: the Y axis will rotate in the plus direction of the tool coordinate system.
- When the [-B (J5)] keys are pressed, rotate in the minus direction.
- When the [+C (J6)] keys are pressed,
 - 6-axis type: the Z axis will rotate in the plus direction.
 - 5-axis type: there is no operation.
- When the [-C (J6)] keys are pressed,
 - 6-axis type: rotate in the minus direction.
 - 5-axis type: there is no operation.

◆◆◆ When alarm No. 5150 occurs ◆◆◆

If alarm No. 5150 (ORIGIN NOT SET) occurs, the origin has not been set correctly. Reconfirm the value input for the origin data.

◆◆◆ Tool length ◆◆◆

The default tool length is 0mm, and the control point is the center of the end axis.

After installing the hand, set the correct tool length in the parameters. Refer to the separate manual "Detailed Explanation of Functions and Operations" for details.

(3) TOOL jog operation

Select TOOL jog mode

<CURRENT>	TOOL	100%	M1	T0
J1:	+0.00	J5:	+0.00	
J2:	+0.00	J6:	+0.00	
J3:	+90.00	:		
J4:	+0.00	:		

XYZ TOOL JOG 3-XYZ CYLNDR =>

TOOL jog mode

JOG

FUNCTION

F1 to F4

Set jog speed

<CURRENT>	TOOL	100%	M1	T0
J1:	+0.00	J5:	+0.00	
J2:	+0.00	J6:	+0.00	
J3:	+90.00	:		
J4:	+0.00	:		

XYZ TOOL JOG 3-XYZ CYLNDR =>

Setting the speed

OVRD ↑ OVRD ↓

[JOG] Press the key and display the jog screen. ("JOG" is displayed on the screen bottom)
 Check that the "TOOL" in jog mode is displayed on the screen.
 If other jog modes are displayed, please press the function key corresponding to the "TOOL." (If the jog mode which he wishes under the screen is not displayed, it is displayed that the [FUNCTION] key is pressed)
 If it finishes jog operation, press the [JOG] key again, or function key which correspond to "close."
 Whenever it presses the key of [OVRD ↑], the override goes up. Conversely, if the [OVRD ↓] key is pressed, it will go down.
 The current setting speed is displayed on screen upper right. Set the override to 10% here for confirmation work.

Moving along the tool coordinate system

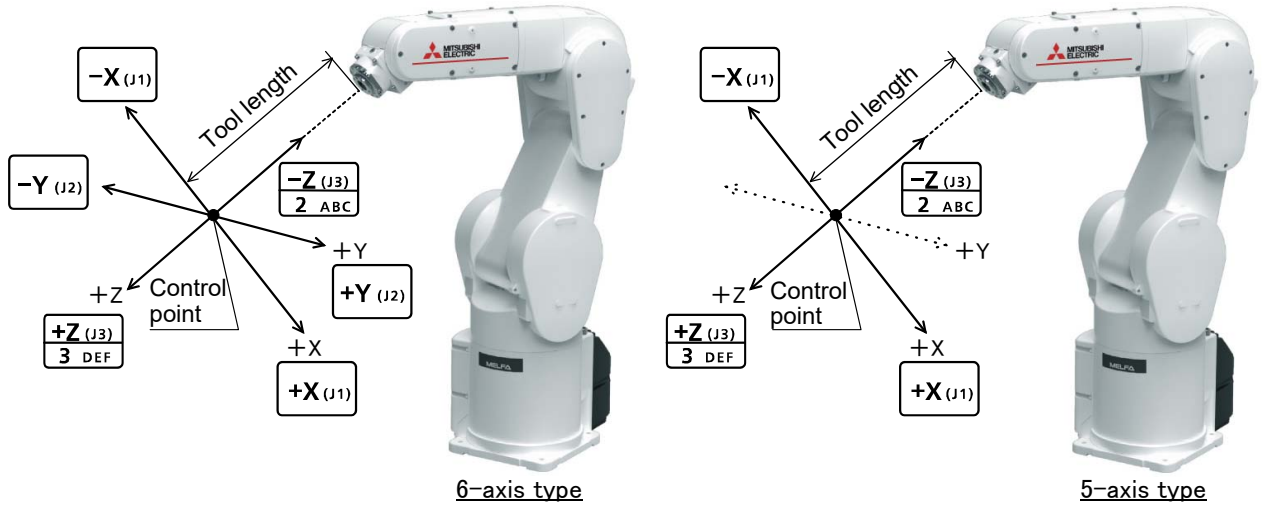

* The direction of the flange will not change

- When the [+X (J1)] keys are pressed, the robot will move along the X axis plus direction of the tool coordinate system.
 When the [-X (J1)] keys are pressed, move along the minus direction.
- When the [+Y (J2)] keys are pressed, the robot will move along the Y axis plus direction of the tool coordinate system. (6-axis type only)
 When the [-Y (J2)] keys are pressed, move along the minus direction. (6-axis type only)
- When the [+Z (J3)] keys are pressed, the robot will move along the Z axis plus direction of the tool coordinate system.
 When the [-Z (J3)] keys are pressed, move along the minus direction.

◆◆◆ When the robot is in the transportation posture ◆◆◆
 There are directions from which linear movement is not possible from the transportation posture. In this case, the robot will not move. Refer to section Page 32, "(1) JOINT jog operation", and move the robot to a position where linear movement is possible, and then carry out XYZ jog.

◆◆◆ If the buzzer of T/B sounds and the robot does not move ◆◆◆

If it is going to move the robot across the operation range, the buzzer of T/B sounds and the robot does not move. In this case, please move to the counter direction.

Changing the flange surface posture

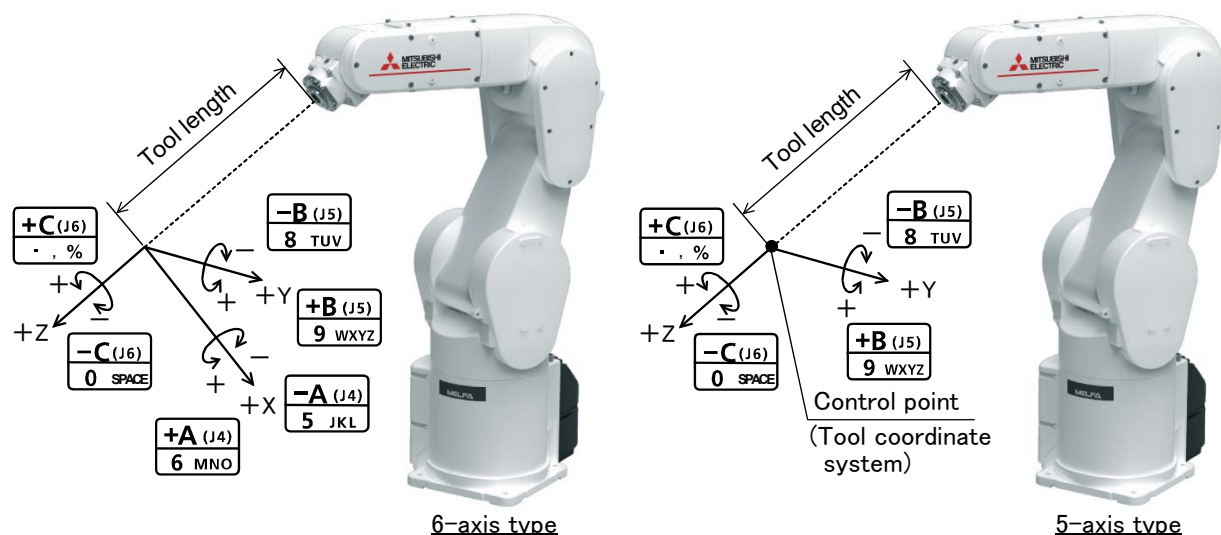

* The control point does not change.

<6-axis type robot>

- When the [+A (J4)] keys are pressed, the X axis will rotate in the plus direction of the tool coordinate system. When the [-A (J4)] keys are pressed, rotate in the minus direction.
- When the [+B (J5)] keys are pressed, the Y axis will rotate in the plus direction of the tool coordinate system. When the [-B (J5)] keys are pressed, rotate in the minus direction.
- When the [+C (J6)] keys are pressed, the Z axis will rotate in the plus direction of the tool coordinate system. When the [-C (J6)] keys are pressed, rotate in the minus direction.

<5-axis type robot>

- There is no operation by the [+A (J4)] key and [-A (J4)] key.
- When the [+B (J5)] keys are pressed, the J5 axis will rotate in the plus direction. When the [-B (J5)] keys are pressed, rotate in the minus direction.
- When the [+C (J6)] keys are pressed, the J6 axis will rotate in the plus direction. When the [-C (J6)] keys are pressed, rotate in the minus direction.

◆◆◆ When alarm No. 5150 occurs ◆◆◆

If alarm No. 5150 (ORIGIN NOT SET) occurs, the origin has not been set correctly. Reconfirm the value input for the origin data.

◆◆◆ Tool length ◆◆◆

The default tool length is 0mm, and the control point is the center of the end axis.

After installing the hand, set the correct tool length in the parameters. Refer to the separate manual "Detailed Explanation of Functions and Operations" for details.

(4) 3-axis XYZ jog operation

Select 3-axis XYZ jog mode

<CURRENT>		3-XYZ	100%	M1	TO
J1:	+0.00	J5:	+0.00		
J2:	+0.00	J6:	+0.00		
J3:	+90.00	:	:		
J4:	+0.00	:	:		

XYZ TOOL JOG **3-XYZ** CYLNDR =>

3-axis XYZ jog mode

[JOG] [FUNCTION] [F1] to [F4]

[JOG] Press the key and display the jog screen. ("JOG" is displayed on the screen bottom)
Check that the "3-XYZ" in jog mode is displayed on the screen.

If other jog modes are displayed, please press the function key modes corresponding to the "3-XYZ." (If the jog mode which he wishes under the screen is not displayed, it is displayed that the [FUNCTION] key is pressed)

If it finishes jog operation, press the [JOG] key again, or function key which correspond to "close."

Whenever it presses the key of [OVRD ↑], the override goes up. Conversely, if the [OVRD ↓] key is pressed, it will go down.

The current setting speed is displayed on screen upper right. Set the override to 10% here for confirmation work.

Set jog speed

<CURRENT>		3-XYZ	100%	M1	TO
J1:	+0.00	J5:	+0.00		
J2:	+0.00	J6:	+0.00		
J3:	+90.00	:	:		
J4:	+0.00	:	:		

XYZ TOOL JOG **3-XYZ** CYLNDR =>

OVRD ↑ OVRD ↓

Setting the speed

Moving along the base coordinate system

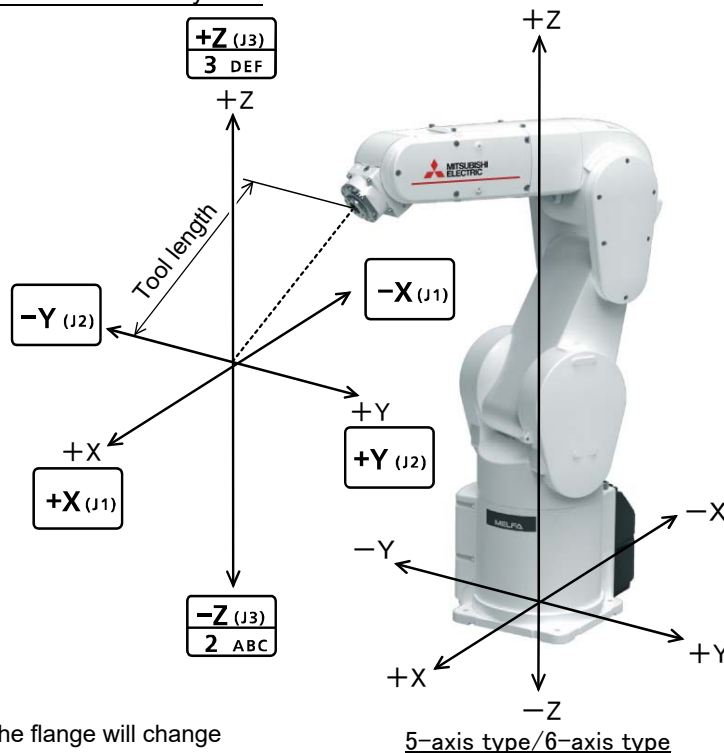

* The direction of the flange will change

- When the[+X (J1)] keys are pressed, the robot will move along the X axis plus direction.
When the[-X (J1)] keys are pressed, move along the minus direction.
- When the[+Y (J2)] keys are pressed, the robot will move along the Y axis plus direction.
When the[-Y (J2)] keys are pressed, move along the minus direction.
- When the[+Z (J3)] keys are pressed, the robot will move along the Z axis plus direction.
When the[-Z (J3)] keys are pressed, move along the minus direction.

◆◆◆ The flange surface end axis posture cannot be maintained with 3-axis XYZ jog. ◆◆◆
With 3-axis XYZ jog, the flange surface end axis posture (orientation) is not maintained when moving linearly in the X, Y or Z axis direction.
Use XYZ jog to maintain the posture.

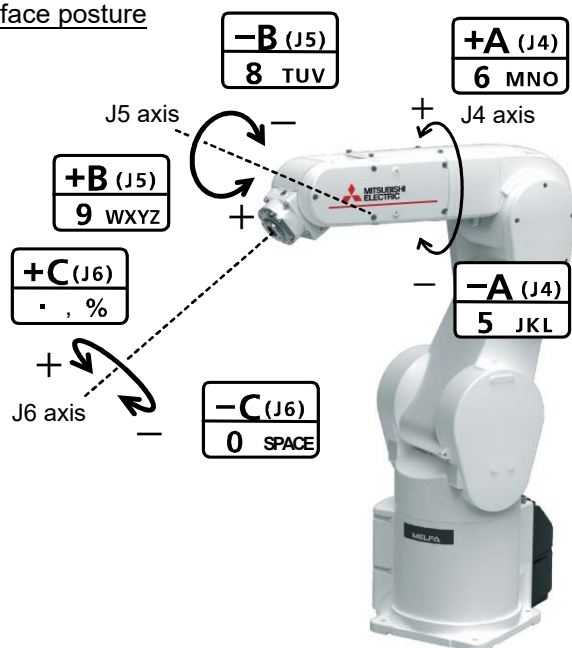
Changing the flange surface posture

* The 5-axis type robot has no J4 axis.

5-axis type/6-axis type

* The wrist pose can be changed maintaining the flange's position.

- When the[+A (J4)] keys are pressed, the J4-axis will rotate in the plus direction. (6-axis type)
At this time, to maintain the flange's position, other axes move simultaneously except J5 and J6.
- When the[-A (J4)] keys are pressed, rotate in the minus direction. (6-axis type)
- When the[+B (J5)] keys are pressed, the J5-axis will rotate in the plus direction.
At this time, to maintain the flange's position, other axes move simultaneously except J4 and J6.
- When the[-B (J5)] keys are pressed, rotate in the minus direction.
- When the[+C (J6)] keys are pressed, the J6-axis will rotate in the plus direction.
When the[-C (J6)] keys are pressed, rotate in the minus direction.

(5) CYLINDER jog operation

Select cylindrical jog mode

<CURRENT>	CYLNDER	100%	M1	T0
J1:	+0.00	J5:	+0.00	
J2:	+0.00	J6:	+0.00	
J3:	+90.00			
J4:	+0.00			

XYZ TOOL JOG 3-XYZ CYLNR =>

CYLINDER jog mode

JOG
FUNCTION
F1 to F4

Set jog speed

<CURRENT>	CYLNDER	100%	M1	T0
J1:	+0.00	J5:	+0.00	
J2:	+0.00	J6:	+0.00	
J3:	+90.00			
J4:	+0.00			

XYZ TOOL JOG 3-XYZ CYLNR =>

Setting the speed

OVRD ↑ OVRD ↓

[JOG] Press the key and display the jog screen. ("JOG" is displayed on the screen bottom)
 Check that the "CYLNDER" in jog mode is displayed on the screen.
 If other jog modes are displayed, please press the function key corresponding to the "CYLNDER." (If the jog mode which he wishes under the screen is not displayed, it is displayed that the [FUNCTION] key is pressed)
 If it finishes jog operation, press the [JOG] key again, or function key which correspond to "close."
 Whenever it presses the key of [OVRD ↑], the override goes up. Conversely, if the [OVRD ↓] key is pressed, it will go down.
 The current setting speed is displayed on screen upper right. Set the override to 10% here for confirmation work.

Moving along an arc centering on the Z axis

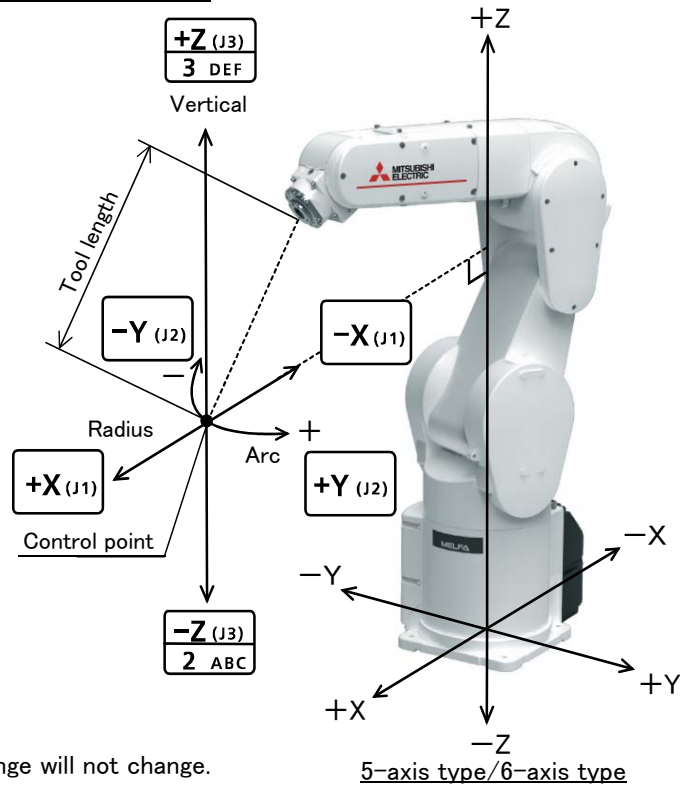

* The direction of the fringe will not change.

Assuming that the current position is on an arc centering on the Z axis, the robot moves along that arc.

- When the[+X (J1)] keys are pressed, the robot will expand in the radial direction.
 When the[-X (J1)] keys are pressed, contract in the radial direction.
- When the[+Y (J2)] keys are pressed, the robot will move along the arc in the plus direction.
 When the[-Y (J2)] keys are pressed, move in the minus direction.
- When the[+Z (J3)] keys are pressed, the robot will move along the Z axis plus direction.
 When the[-Z (J3)] keys are pressed, move along the minus direction.

Changing the flange surface posture

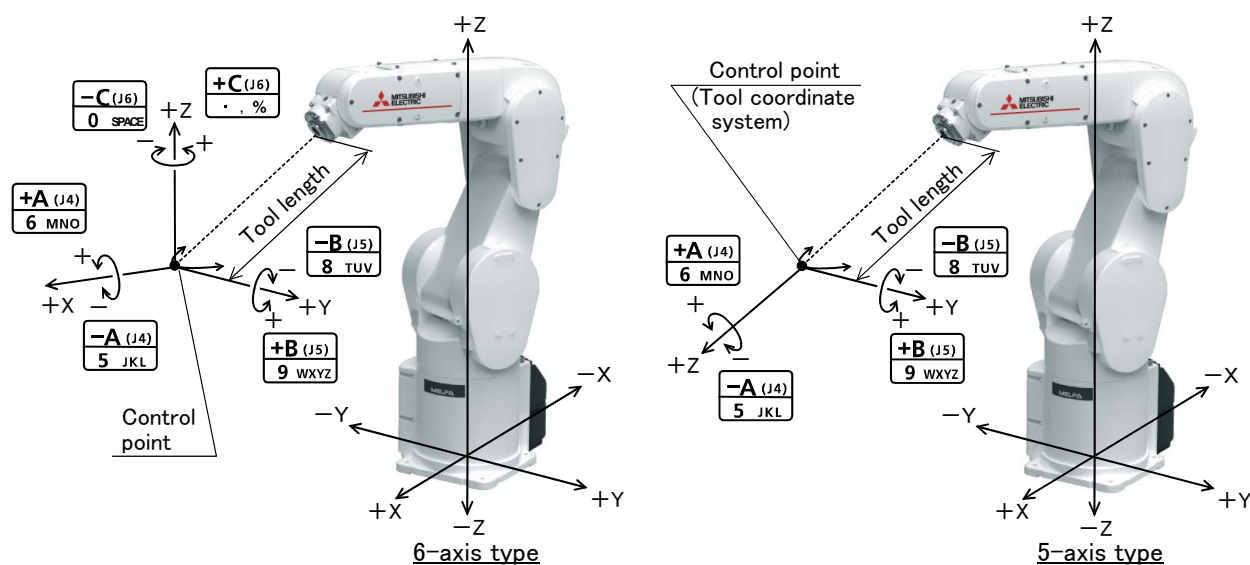

* The flange position does not change.
This is the same as the A, B and C axis XYZ jog operation.

- When the [+A (J4)] keys are pressed,
 - 6-axis type: the X axis will rotate in the plus direction.
 - 5-axis type: the Z axis will rotate in the plus direction of the tool coordinate system.
- When the [-A (J4)] keys are pressed, rotate in the minus direction.
- When the [+B (J5)] keys are pressed,
 - 6-axis type: the Y axis will rotate in the plus direction.
 - 5-axis type: the Y axis will rotate in the plus direction of the tool coordinate system.
- When the [-B (J5)] keys are pressed, rotate in the minus direction.
- When the [+C (J6)] keys are pressed,
 - 6-axis type: the Z axis will rotate in the plus direction.
 - 5-axis type: There is no operation.
- When the [-C (J6)] keys are pressed,
 - 6-axis type: rotates in the minus direction.
 - 5-axis type: There is no operation.

(6) Work jog operation

Setting of the work coordinates system is necessary.

By this jog operation, robot can be move along with the direction of work (or working table etc.), so teaching operations get easier.

When jog operation, select by which work coordinates the robot moves

The setting method of the work coordinates system using T/B (R32TB) is shown in the following.

(Parameter: Setting the coordinate value to WK n CORD ("n" is meaning the number (1-8) of work coordinates) can also set up the work coordinates system. Refer to the separate manual "Detailed Explanation of Functions and Operations" for details of parameter.)

The work coordinates system teaches and sets up the three points (WO, WX, WY).

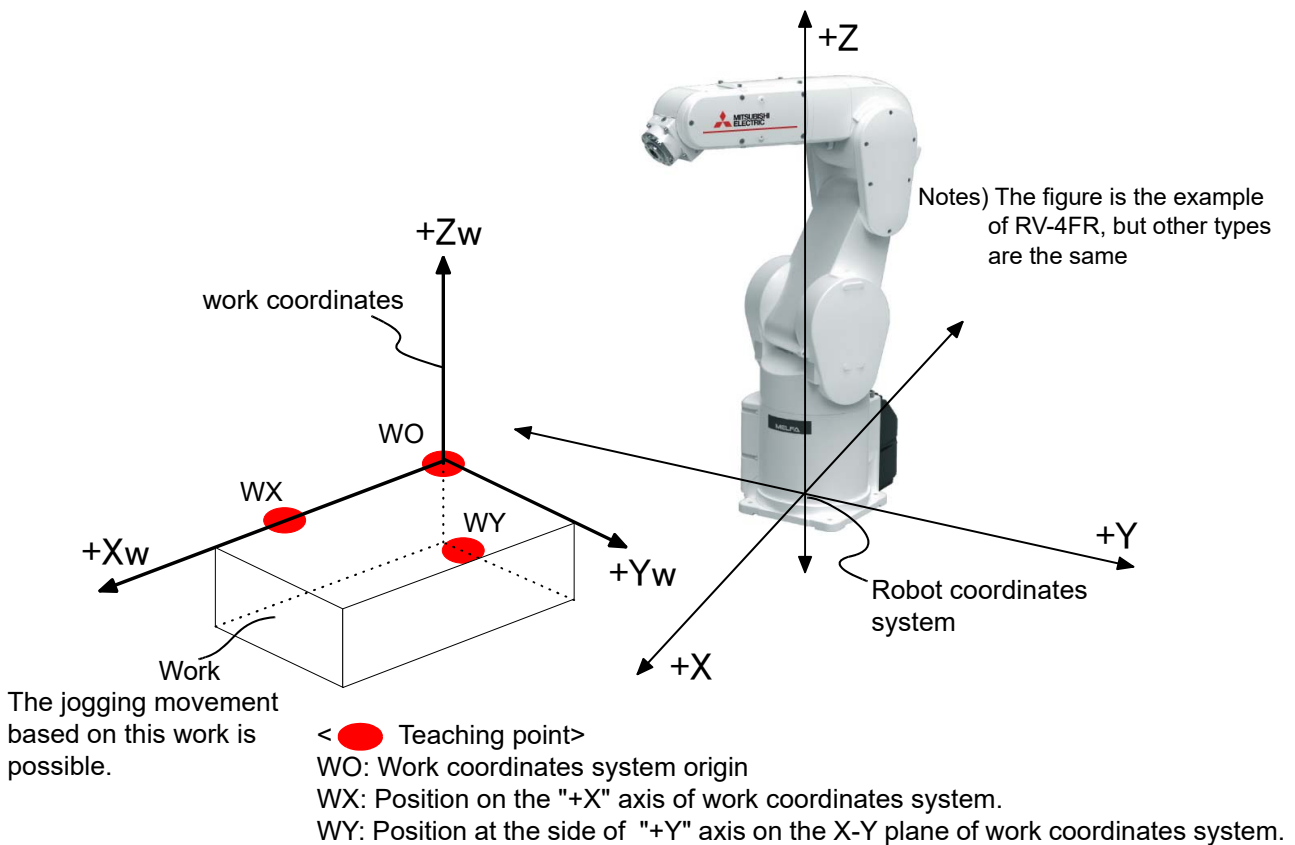

[Supplement] : The coordinate values which use all three teaching points for setting of the work coordinates system are each only X, Y, and the Z-axis. Although the coordinate value of A, B, and C axis is not used, positioning will get easy if the XYZ jog or TOOL jog movement is effected with the same value. (The direction of the hand is the same)

Fig.2-22 : Setting of the work coordinates system (teaching point)

The setting (definition) method of the work coordinates system is shown in the following.

1) Select "6.ENHANCED" screen on the <MENU> screen.

```

<MENU>
1. FILE/EDIT          2. RUN
3. PARAM.            4. ORIGIN/BRK
5. SET/INIT.        6. ENHANCED
  
```

123 CLOSE



```

<EMHANCED>
1. SQ DIRECT          2. WORK COORD.
3. FORCE SENSOR CONTROL
  
```

123 CLOSE

2) Press the [2] keys in the menu screen and select "2. WORK COORD."

```

<EMHANCED>
1. SQ DIRECT          2. WORK COORD.
3. FORCE SENSOR CONTROL
  
```

123 CLOSE



```

<WORK COORD>          WORK NUMBER (1)
                     TEACHING POINT (WO)
X: 0.00
Y: 0.00
Z: 0.00
  
```

TEACH WX 123 WY DEFINE

The screen shows the coordinate value of the origin (WO) of the work coordinates number 1.

3) Selection of the work coordinates number

Press the [FUNCTION] keys, and display "W: JUMP" function. Press the function key corresponding to "W: JUMP"

```

<WORK COORD>          WORK NUMBER (1)
                     TEACHING POINT (WO)
X: 0.00
Y: 0.00
Z: 0.00
  
```

W. JUMP W. GRID 123 CLOSE



```

<WORK JUMP>
CHOOSE ONE OF THE WORK NUMBER
1-8.
  
```

123 CLOSE

Press numeral key [1] - [8] and specify the work coordinates number. The coordinate value of the specified work coordinates system is displayed.

```

<WORK JUMP>
CHOOSE ONE OF THE WORK NUMBER
1-8.
  
```

123 CLOSE



```

<WORK COORD>          WORK NUMBER (2)
                     TEACHING POINT (WO)
X: 0.00
Y: 0.00
Z: 0.00
  
```

W. JUMP W. GRID 123 CLOSE

The screen is the example which specified the work coordinates number 2. ("2" at the upper right of the screen)

Operation will be canceled if the [CLOSE] key is pressed.

4) The teaching of the work coordinates system

Teach the three points shown in Fig. 2-22. Confirm the name currently displayed on the "TEACHING POINT" at the upper right of the screen. If it differs, press the function key corresponding to each point(WO, WX, WY) to teach. Move the robot's arm by jog operation (other jogging movement), and press the function key corresponding to "TEACH."([F1]) The confirmation screen is displayed.

```

<WORK COORD>          WORK NUMBER (2)
                     TEACHING POINT (WO)
X: 0.00
Y: 0.00
Z: 0.00
  
```

TEACH WX 123 WY DEFINE



```

<WORK COORD>          WORK NUMBER (2)
TEACHING POINT (WO)
RECORD CURRENT POSITION.
OK?
  
```

Yes 123 No

Specify the teaching point [WO],[WX],[WY]
teaching the position [TEACH]

Presses the function key corresponding to "Yes", the robot's current position is registered, and the registered coordinates value is display. Operation will be canceled if the [CLOSE] key is pressed.

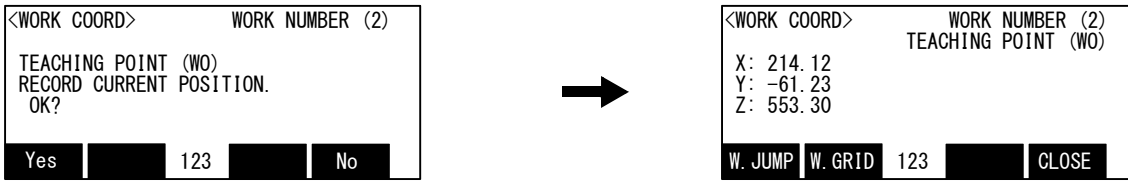

Teach the three points, WO, WX, and WY, by the same operation.

The position data taught here is each registered into the following parameters. ("n" means the work coordinates numbers 1-8)

WO= parameter: WKnWO

WX= parameter: WKnWX

WY= parameter: WKnWY

5) Setting of work coordinates (definition)

If the function key corresponding to "DEFINE" ([F1]) is pressed, the work coordinates system will be calculated using the three points, and the result will be displayed.

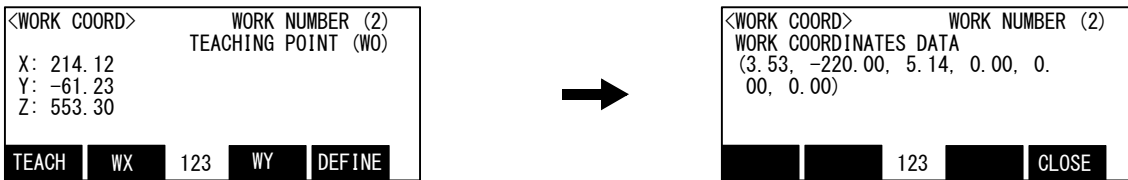

The alarm occurs if the work coordinates system is incalculable. (There are the three points on the straight line, or the two points have overlapped) In this case, reset alarm and re-teach the three points.

This work coordinate data is registered into parameter: WKnCORD. ("n" means the work coordinates numbers 1-8)

If the function key corresponding to "CLOSE" is pressed, it will return to the previous screen.

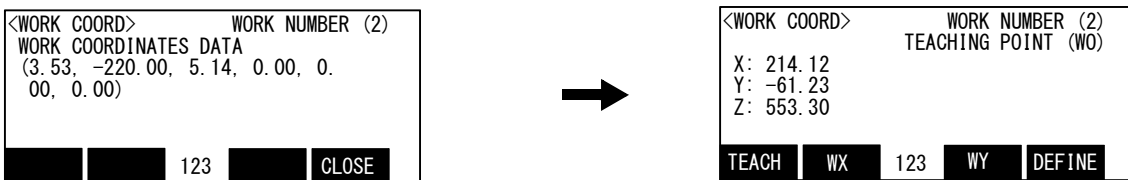

6) Finishing of setting the work coordinates

Press the [FUNCTION] keys, and display "CLOSE" function. Press the function key corresponding to "CLOSE". Returns to the <MENU> screen.

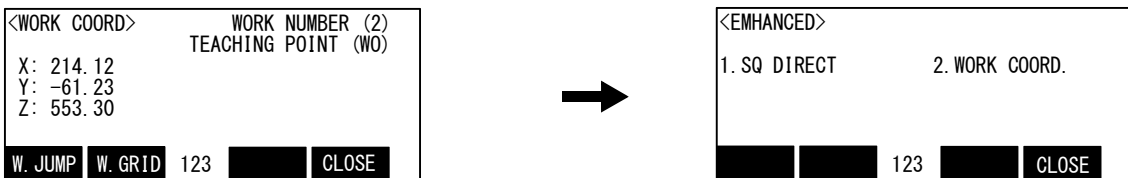

Although setting of work coordinates is finishing above, confirmation of work coordinates can be done by pressing the function key corresponding to "W GRID."([F2])

<WORK COORD>	WORK NUMBER (2)
X: 214.12	TEACHING POINT (WO)
Y: -61.23	
Z: 553.30	
W. JUMP	W. GRID 123
	CLOSE



<WORK COORD>	WORK NUMBER (2)
WORK COORDINATES DATA	
(3.53, -220.00, 5.14, 0.00, 0.	
00, 0.00)	
	123
	CLOSE

Return to the previous screen by pressing the [CLOSE] ([F4]) key.

Then, the operation method of the work jog is shown. Change to the work jog after nearing the work.

Select WORK jog mode

<CURRENT>	WORK	100%	M1 TO W1
J1: +0.00	J5: +0.00		
J2: +0.00	J6: +0.00		
J3: +90.00	:		
J4: +0.00	:		
XYZ	TOOL	JOG	3-XYZ CYLNDR =>
WORK jog mode			



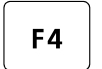

 to 

Note) The displayed values are based on the XYZ coordinate system.

[JOG] Press the key and display the jog screen. ("JOG" is displayed on the screen bottom)

Check that the "WORK" in jog mode is displayed on the screen.

If other jog modes are displayed, please press the function key corresponding to the "WORK." (If the jog mode which he wishes under the screen is not displayed, it is displayed that the [FUNCTION] key is pressed)

If it finishes jog operation, press the [JOG] key again, or function key which correspond to "close."

Confirmation and selection of the work coordinates system

<CURRENT>	WORK	100%	M1 TO W1
J1: +0.00	J5: +0.00		
J2: +0.00	J6: +0.00		
J3: +90.00	:		
J4: +0.00	:		
XYZ	TOOL	JOG	3-XYZ CYLNDR =>



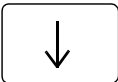

Select the work coordinates system

Target work coordinates system

Confirm the target work coordinates system.

The current target number is displayed on the screen upper right. (W1 - W8)

The number of work coordinates can be changed by the arrow key [Upper arrow], [Lower arrow]

Push the key [Upper arrow], the number will increase. (W1, W2, W8) Conversely, push the key [Lower arrow], the number will decrease



CAUTION

Always confirm that the number of the target work coordinates system is displayed correctly (Display of W1-W8 at the upper right of the screen)

If mistaken, the robot will move in the direction which is not meant and will cause the damage and the personal injuries.

Set jog speed

<CURRENT>	WORK	70%	M1 TO
J1: +0.00	J5: +0.00		
J2: +0.00	J6: +0.00		
J3: +90.00	:		
J4: +0.00	:		
XYZ	TOOL	JOG	3-XYZ CYLNDR =>





Setting the speed

Whenever it presses the key of [OVRD (Upper arrow)], the override goes up. Conversely, if the [OVRD (Lower arrow)] key is pressed, it will go down.

The current setting speed is displayed on screen upper right.

Set the override to 10% here for confirmation work

The WORK jog operation and the Ex-T jog operation can be switched by setting the parameters WK1-JOGMD to WK8JOGMD of each work coordinates system.
The respective operations are as follows.

WORK jog operation mode	Conventional WORK jog	Ex-T jog
Parameters WKnJOGMD (n is 1 to8) setting	0 (initial value)	1
XYZ key operation	Moves along each axis of the work coordinates system	Same as the conventional WORK jog
ABC key operation	With the control point position maintained, the direction changes along the work coordinates system.	While the control point position is changed, the direction changes on each axis of the work coordinates system.

* The Ex-T jog cannot be used for the 5-axis type. Even when "1" is set in the parameter WKnJOGMD, the operation is the same as the conventional WORK jog operation.

The jog movement based on work coordinates system

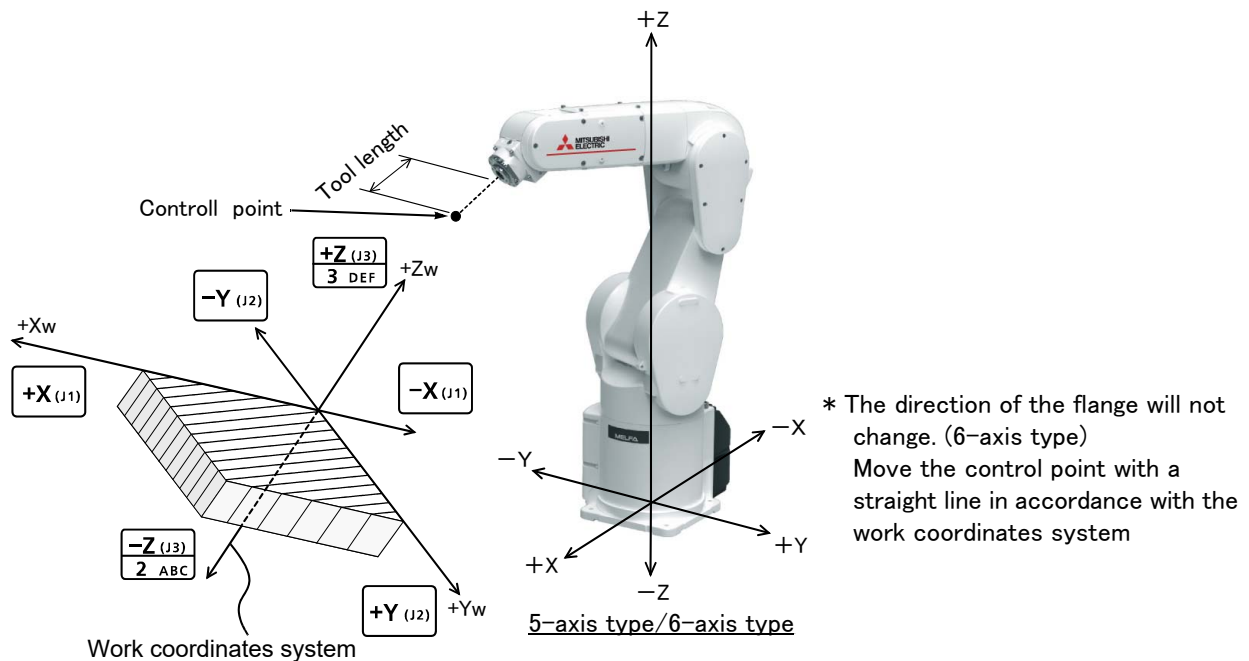

- When the [+X (J1)] keys are pressed, the robot will move along the X axis (Xw) plus direction on the work coordinates system.
When the [-X (J1)] keys are pressed, Move along the minus direction.
- When the [+Y (J2)] keys are pressed, the robot will move along the Y axis (Yw) plus direction on the work coordinates system.
When the [-Y (J2)] keys are pressed, Move along the minus direction.
- When the [+Z (J3)] keys are pressed, the robot will move along the Z axis (Zw) plus direction on the work coordinates system.
When the [-Z (J3)] keys are pressed, Move along the minus direction.

When the X, Y, or Z keys are used, the operation is the same in the WORK jog and the Ex-T jog modes.

Changing the flange surface posture

<1> Work jog mode

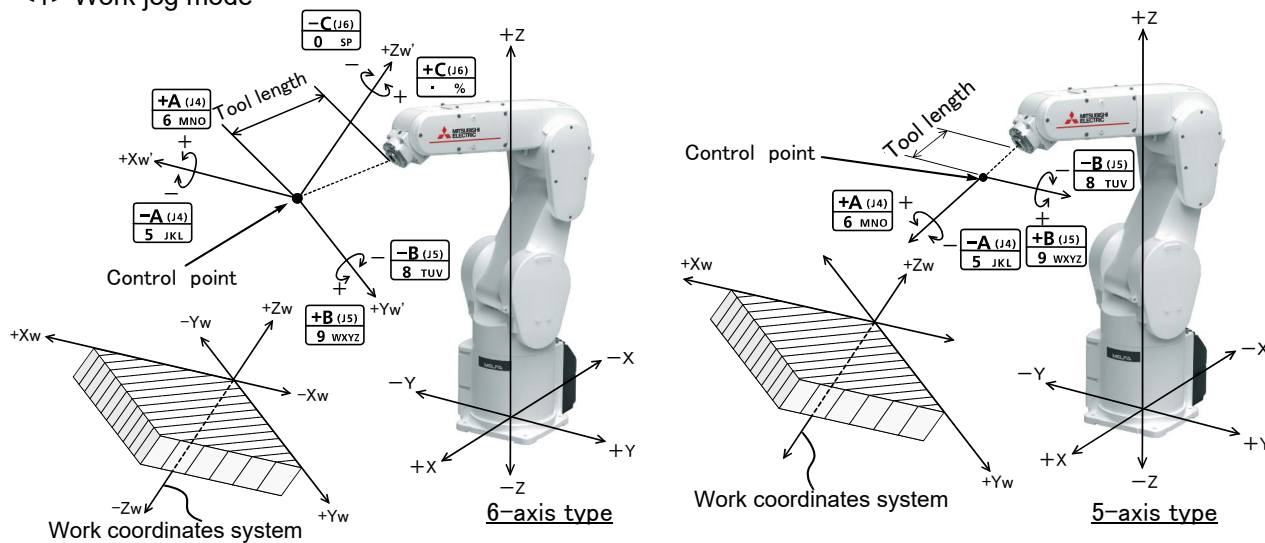

* The position of the control point does not change.

Change the direction of the flange in accordance with the work coordinates system.

- When the [+A (J4)] keys are pressed,
 - 6-axis type: the X axis will rotate in the plus direction of the work coordinate system.
 - 5-axis type: the Z axis will rotate in the plus direction of the tool coordinate system.
 When the [-A (J4)] keys are pressed, rotate in the minus direction.
- When the [+B (J5)] keys are pressed,
 - 6-axis type: the Y axis will rotate in the plus direction of the work coordinate system.
 - 5-axis type: the Y axis will rotate in the plus direction of the tool coordinate system.
 When the [-B (J5)] keys are pressed, rotate in the minus direction.
- When the [+C (J6)] keys are pressed,
 - 6-axis type: the Z axis will rotate in the plus direction of the work coordinate system.
 - 5-axis type: There is no operation.
 When the [-C (J6)] keys are pressed,
 - 6-axis type: rotate in the minus direction.
 - 5-axis type: There is no operation.

<2> Ex-T jog mode

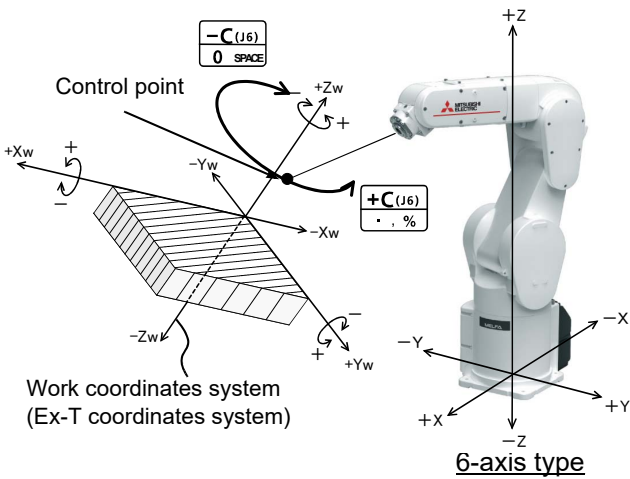
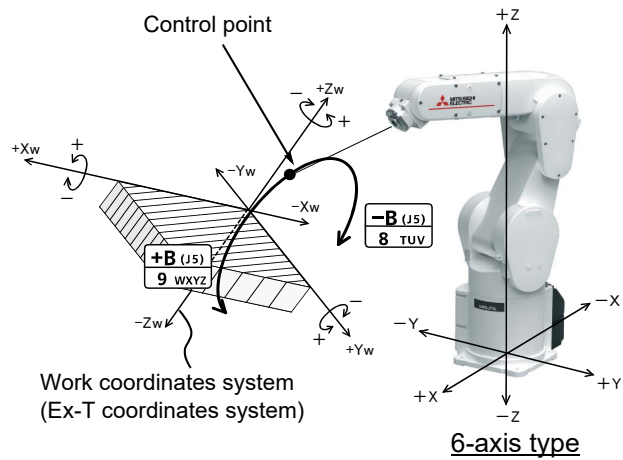
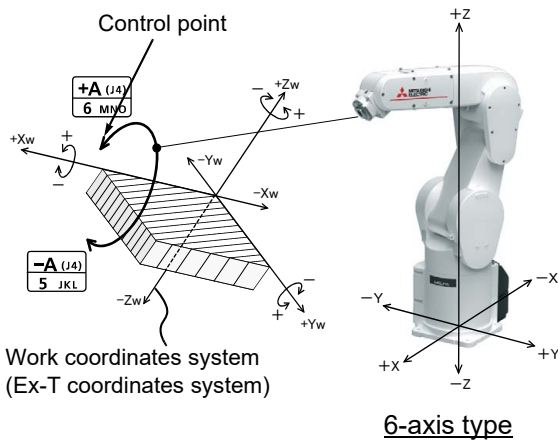

- * The control point rotates around each axes of work coordinates system (Ex-T coordinates system). When the [+A (J4)] or the [-A (J4)] key is pressed, the control point rotates around the Xw axis. When the [+B (J5)] or the [-B (J5)] key is pressed, the control point rotates around the Yw axis. When the [+C (J6)] or the [-C (J6)] key is pressed, the control point rotates around the Zw axis.
- * The Ex-T jog cannot be used for the 5-axis type.

- When the [+A (J4)] keys are pressed, the control point will rotate in the plus direction around the X axis (Xw) of work coordinates system (Ex-T coordinates system).
When the [-A (J4)] keys are pressed, the control point will rotate in the minus direction.
- When the [+B (J5)] keys are pressed, the control point will rotate in the plus direction around the Y axis (Yw) of work coordinates system. (Ex-T coordinates system).
When the [-B (J5)] keys are pressed, the control point will rotate in the minus direction.
- When the [+C (J6)] keys are pressed, the control point will rotate in the plus direction around the Z axis (Zw) of work coordinates system. (Ex-T coordinates system).
When the [-C (J6)] keys are pressed, the control point will rotate in the minus direction.

◆◆◆ When the robot is in the transportation posture ◆◆◆
 There are directions from which linear movement is not possible from the transportation posture. In this case, the robot will not move. Refer to section [Page 32, "\(1\) JOINT jog operation"](#), and move the robot to a position where linear movement is possible, and then carry out XYZ jog.

◆◆◆ If the buzzer of T/B sounds and the robot does not move ◆◆◆
 If it is going to move the robot across the operation range, the buzzer of T/B sounds and the robot does not move. In this case, please move to the counter direction.

◆◆◆ Tool length ◆◆◆

The default tool length is 0mm, and the control point is the center of the end axis.

After installing the hand, set the correct tool length in the parameters. Refer to the separate manual "Detailed Explanation of Functions and Operations" for details.

2.3.4 Setting the hand parameters

Set the parameters to set the hand I/O type and the hand condition according to the robot hand to be used. Refer to the separate volume, "Instruction Manual/Detailed Explanations of Functions and Operations" for how to set parameters.

Table 2-5 : Hand parameter

Parameter	Parameter name	Details explanation	Factory setting
Hand I/O type	HIOTYPE	Set either the sink type or the source type for the solenoid valve and the logic of the hand input signal. -1: Not set 0: Source type 1: Sink type	-1
Hand condition	HNDDAT* * is 0 to 8	Set the initial condition of the hand. (Specify with the tool coordinate system.) (Weight, size X, size Y, size Z, center of gravity X, center of gravity Y, center of gravity Z) Unit: Kg, mm  CAUTION Set the hand and workpiece conditions correctly. If a value lower than the actual load is set, the life of robot mechanical parts may be shortened.	The setting varies depending on the model.
Hand condition setting check	HNDDCHK	Enable or disable whether to notify that the HNDDAT parameter is not set. 0: Disabled 1: Enabled When this parameter is set to "1" (enabled), error C0330 will occur upon power on of the controller if all the values of the hand condition parameter HNDDAT* (* = 0 to 8) are not set (not changed from the initial values). When this parameter is set to "0" (disabled), the above settings are not checked, and error C0330 does not occur even if the hand conditions are not set. This parameter is available with controller software version C2d or later.	1

3 Installing the option devices

3.1 Installing the operating range change (RV-2FR series)

3.1.1 Installing the J1 axis operating range change

The configuration, changeable angle, and installation outline of J1 axis operating range change (1S-DH-11J1) are shown below.

(1) Configuration

The configuration parts of this option are shown in Table 3-7. Please confirm.

Table 3-1 : Configuration devices

No.	Part name	Qty.	Mass (kg)	Remarks
<1>	Variable stopper block	1	0.5	
<2>	Fixing stopper	2		
<3>	Screw (M5x20)	6		Screw with a captive washer for installing the stoppers.

<1> Variable stopper block

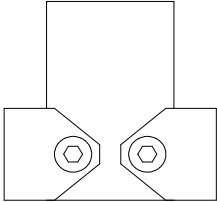

<2> Fixing stopper

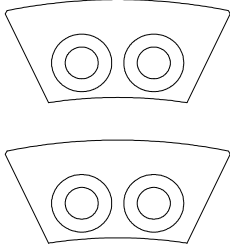

<3> Screw

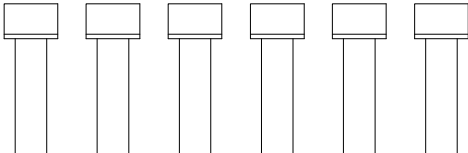

(2) Changeable angle

The changeable angle of J1 axis is shown in Table 3-8. Refer to Table 3-8 to confirm the installation position of the fixing stopper corresponding to the angle to change or setting value of a parameter. Refer to Fig. 3-1 for details of the installation positions of the stoppers.

Table 3-2 : Changeable angle of J1 axis

Operating range (Parameter (MEJAR) setting value)		Mechanical stopper angle		Fixing stopper installation position ^{Note1)}	
- (minus) side	+ (plus) side	- (minus) side	+ (plus) side (Parameter (MORG) setting value)		
-240	+240	-243	+243	Not equipped (Default)	
-90	+210	-93	+217	A	
-150	+150	-155	+155	B	
-210	+90	-217	+93	C	
-90	+150	-93	+155	A	B
-90	+90	-93	+93	A	C
-150	+90	-155	+93	B	C

Note1) Characters A, B, and C in this table are correspond to the same characters in Fig. 3-1.

(3) Installation procedure

The installation procedure of the J1 axis operating range change is shown below.

When installing this option, you should move the J1 axis to the 0 degrees by jog operation previously, and do this work.

CAUTION

When installing this option for safety, you should cut off the power supply of the controller.

Each screw should be tightened with 9.5 Nm torque. Please confirm the screws are surely tightened by 9.5 Nm torque before moving the robot.

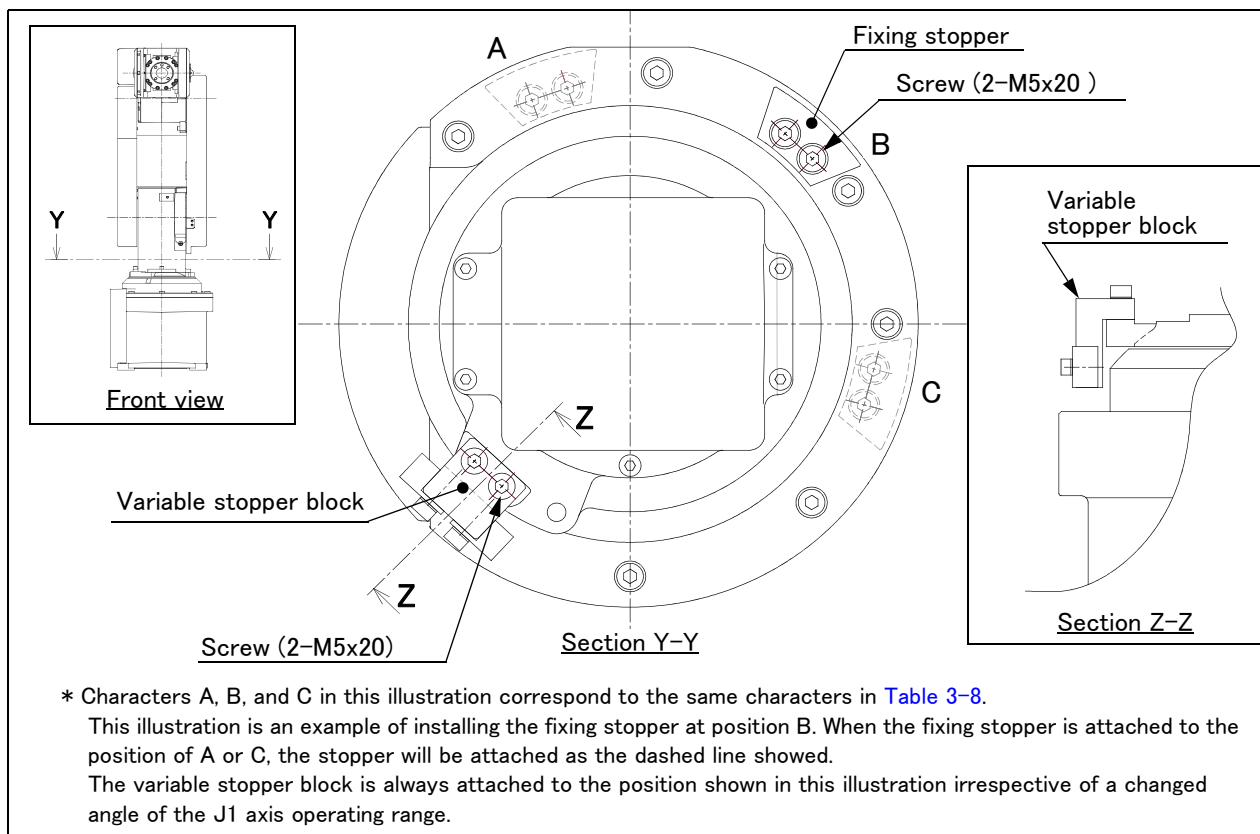

Fig.3-1 : Installation procedure of optional stoppers

- 1) Refer to [Table 3-8](#) and confirm the installation position of the fixing stopper corresponding to the angle to change.
With the combination of angles of a plus side and a minus side, the fixing stoppers are required to install on two places.
- 2) Refer to [Fig. 3-1](#) and install the fixing stopper to the installation position corresponding to the angle to change. Tighten the screw firmly to fix the fixing stopper. (Tightening torque: 9.5 Nm)
- 3) Install the variable stopper block to the position shown in [Fig. 3-1](#). Tighten screws firmly to fix the variable stopper block as well as the fixing stopper. (Tightening torque: 9.5 Nm)

(4) Setting the parameter

Specify the operating range to parameter MEJAR and the mechanical stopper angle to parameter MORG with appropriate values (variable angles given in [Table 3-8](#)) by the following steps.

- 1) Turn on the power supply.
- 2) Set up the operating range changed into parameter MEJAR.
MEJAR: (J1 minus (-) side, J1 plus (+) side, ***, ***, ***, ***, ...).
- 3) Set up the + side mechanical stopper angle changed into parameter MORG.
MORG: (J1 plus (+) side mechanical stopper angle, ***, ***, ...).

Note) Refer to the separate "Instruction manual/Detailed Explanation of Functions and Operations" for the details of the setting method.

(5) Check the operating range

After changing the parameter, turn off the controller power and turn on again. And, move the axis changed by joint jog operation to the limit of the operating range. Confirm that the robot stops by limit over at the changed angle.

The changing of the J1 axis operating range is completed.

3.1.2 Installing the J2 axis operating range change

The configuration, changeable angle, and installation outline of J2 axis operating range change (1S-DH-11J2) are shown below.

(1) Configuration

The configuration parts of this option are shown in Table 3-3. Please confirm.

Table 3-3 : Configuration devices

No.	Part name	Qty.	Mass (Kg)	Remarks
<1>	Stopper A	1	0.1	
<2>	Stopper B	1		
<3>	Screw (M4x10)	4		Screw with a captive washer for installing the stoppers.

(2) Changeable angle

The changeable angle of J2 axis is shown in Table 3-4. Refer to Table 3-4 to confirm the installation position of the stopper corresponding to the angle to change or setting value of a parameter. Refer to Fig. 3-2 for details of the installation position of the stoppers.

Table 3-4 : Changeable angle of J2 axis

Operating range (Parameter (MEJAR) setting value)		Mechanical stopper angle		Stopper
- (minus) side	+ (plus) side	- (minus) side	+ (plus) side (Parameter (MORG) setting value)	
-120: RV-2FR/2FRB -117: RV-2FRL/2FRLB	+120	-121: RV-2FR/2FRB -118: RV-2FRL/2FRLB	+121	Not equipped (Default)
-120: RV-2FR/2FRB -117: RV-2FRL/2FRLB	+30	-121: RV-2FR/2FRB -118: RV-2FRL/2FRLB	+33	Stopper A
-30	+120	-33	+121	Stopper B
-30	+30	-33	+33	Stopper A and B

(3) Installation procedure

The installation procedure of the J2 axis operating range change is shown below.

When installing this option, you should move the J2 axis to the 0 degrees by jog operation previously, and do this work.

CAUTION

When installing this option for safety, you should cut off the power supply of the controller.

Each screw should be tightened with 4.6 Nm torque. Please confirm the screws are surely tightened by 4.6 Nm torque before moving the robot.

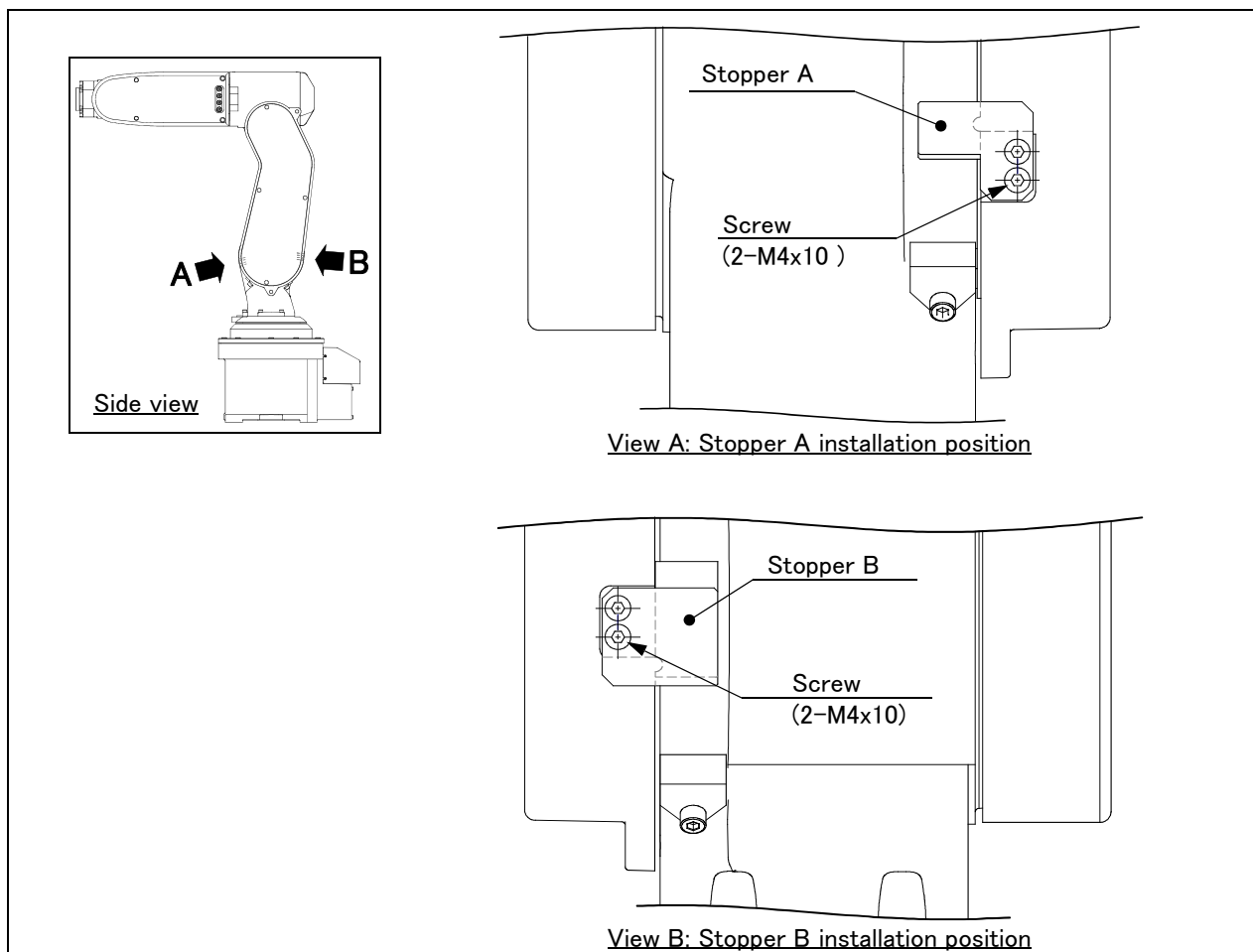

Fig.3-2 : Installation procedure of optional stoppers

- 1) Refer to [Table 3-4](#) and confirm the stopper corresponding to the angle to change.
With the combination of angles of a plus side and a minus side, both A and B stoppers are required to be installed.
- 2) Refer to [Fig. 3-2](#) and install the required stopper to the installation position. Tighten screws firmly to fix the stopper. (Tightening torque: 4.6 Nm)

(4) Setting the parameter

Specify the operating range to parameter MEJA and the mechanical stopper angle to parameter MORG with appropriate values (variable angles given in [Table 3-4](#)) by the following steps.

- 1) Turn on the power supply.
- 2) Set up the operating range changed into parameter MEJAR.
MEJAR: (***, ***, J2 minus (-) side, J2 plus (+) side, ***, ***, ...).
- 3) Set up the - side mechanical stopper angle changed into parameter MORG.
MORG: (***, J2 minus (-) side mechanical stopper angle, ***, ...).

Note) Refer to the separate "Instruction manual/Detailed Explanation of Functions and Operations" for the details of the setting method.

(5) Check the operating range

After changing the parameter, turn off the controller power and turn on again. And, move the axis changed by joint jog operation to the limit of the operating range. Confirm that the robot stops by limit over at the changed angle.

The changing of the J2 axis operating range is completed.

3.1.3 Installing the J3 axis operating range change

The configuration, changeable angle, and installation outline of J3 axis operating range change (1S-DH-11J3) are shown below.

(1) Configuration

The configuration parts of this option are shown in Table 3-5. Please confirm.

Table 3-5 : Configuration devices

No.	Part name	Qty.	Mass (Kg)	Remarks
<1>	Stopper	1	0.1	
<2>	Screw (M4x10)	1		Screw with a captive washer for installing the stoppers.
<3>	Screw (M4x25)	1		Screw with a captive washer for installing the stoppers.

<1> Stopper

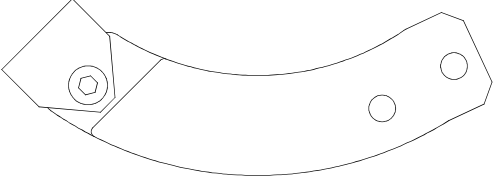

<2> Screw

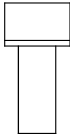

<3> Screw

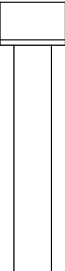

(2) Changeable angle

The changeable angle of J3 axis is shown in Table 3-6. Refer to Table 3-6 to confirm the setting value of a parameter.

Table 3-6 : Changeable angle of J3 axis

Operating range (Parameter (MEJAR) setting value)		Mechanical stopper angle		Stopper
- (minus) side	+ (plus) side	- (minus) side	+ (plus) side	
0	+160	-1	+161	Not equipped (Default)
+70	+160	+69	+161	Equipped

(3) Installation procedure

The installation procedure of the J3 axis operating range change is shown below.

When installing this option, you should move the J3 axis to the +160 degrees by jog operation previously, and do this work.

⚠ CAUTION

When installing this option for safety, you should cut off the power supply of the controller.

Each screw should be tightened with 4.6 Nm torque. Please confirm the screws are surely tightened by 4.6 Nm torque before moving the robot.

- 1) Remove the resin stopper (left side) installed to the robot arm. The resin stopper (right side) must not remove.

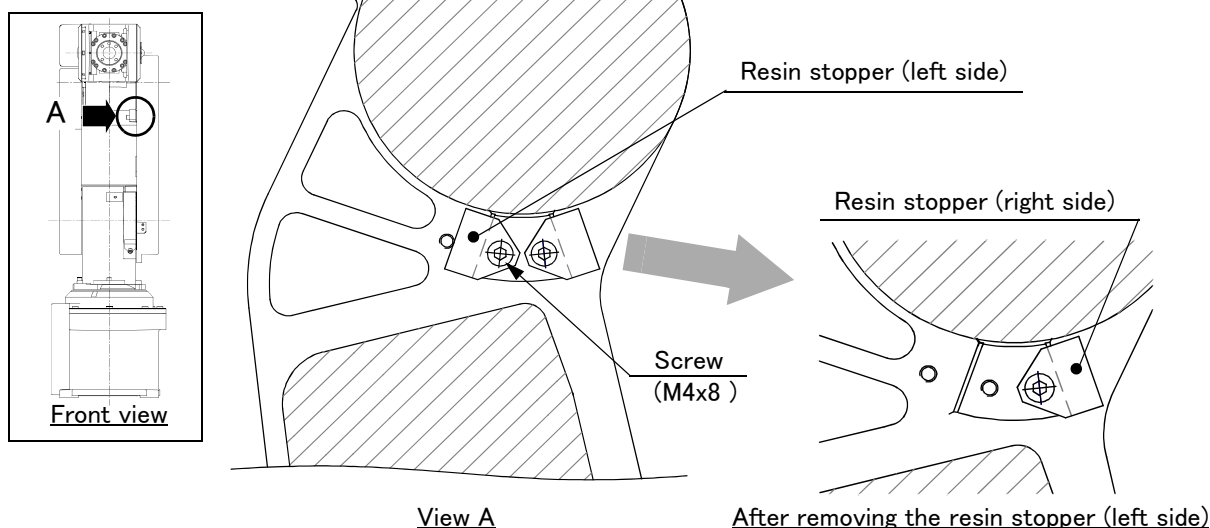

- 2) Install the stopper of the operating range change (option). Tighten screws firmly to fix the stopper. (Tightening torque: 4.6 Nm)

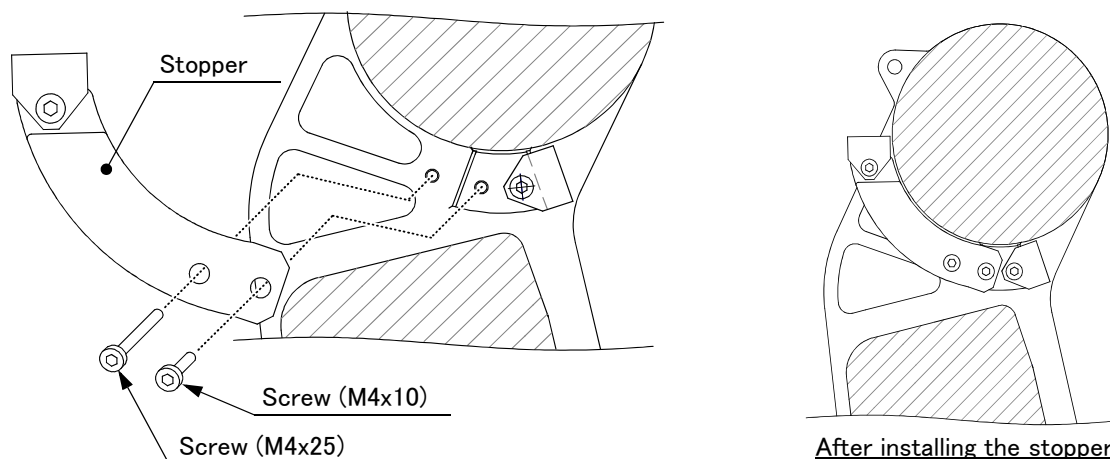

(4) Setting the parameter

Specify the operating range to parameter MEJAR with appropriate values (variable angles given in [Table 3-6](#)) by the following steps.

- 1) Turn on the power supply.
- 2) Set up the operating range changed into parameter MEJAR.
MEJAR: (**, **, **, **, J3 minus (-) side, J3 plus (+) side, ...).

Note) Refer to the separate "Instruction manual/Detailed Explanation of Functions and Operations" for the details of the setting method.

(5) Check the operating range

After changing the parameter, turn off the controller power and turn on again. And, move the axis changed by joint jog operation to the limit of the operating range. Confirm that the robot stops by limit over at the changed angle.

The changing of the J3 axis operating range is completed.

3.2 Installing the J1 axis operating range change (RV-4FR/7FR/13FR series)

The configuration, changeable angle and installation outline of J1 axis operating range change are shown below.

3.2.1 RV-4FR/7FR series

(1) Configuration

The configuration parts of this option are shown in Table 3-7. Please confirm.

The option for RV-4FR series is 1F-DH-03, and RV-7FR series is 1F-DH-04.

Table 3-7 : Configuration devices

No.	Part name	Qty.	Mass (kg)	Remarks
RV-4FR series				
<1>	Stopper plate	2	1.1	One piece each for + side/- side
<2>	Fixing block A	2		One piece each for + side/- side
<3>	Fixing block B	1		+ side
<4>	Fixing block C	1		- side
<5>	Variable stopper block	2		One piece each for + side/- side
<6>	Screw (M10x20)	2		Use for mechanical stopper screw A and B
<7>	Screw (M6x25)	2		For fixing
<8>	Screw (M6x20)	16		For fixing
RV-7FR series				
<1>	Stopper plate	2	1.1	One piece each for + side/- side
<2>	Fixing block A	2		One piece each for + side/- side
<3>	Fixing block B	1		+ side
<4>	Fixing block C	1		- side
<5>	Variable stopper block	2		One piece each for + side/- side
<6>	Screw (M12x25)	2		Use for mechanical stopper screw A and B
<7>	Screw (M8x25)	14		For fixing
<8>	Screw (M8x20)	4		For fixing

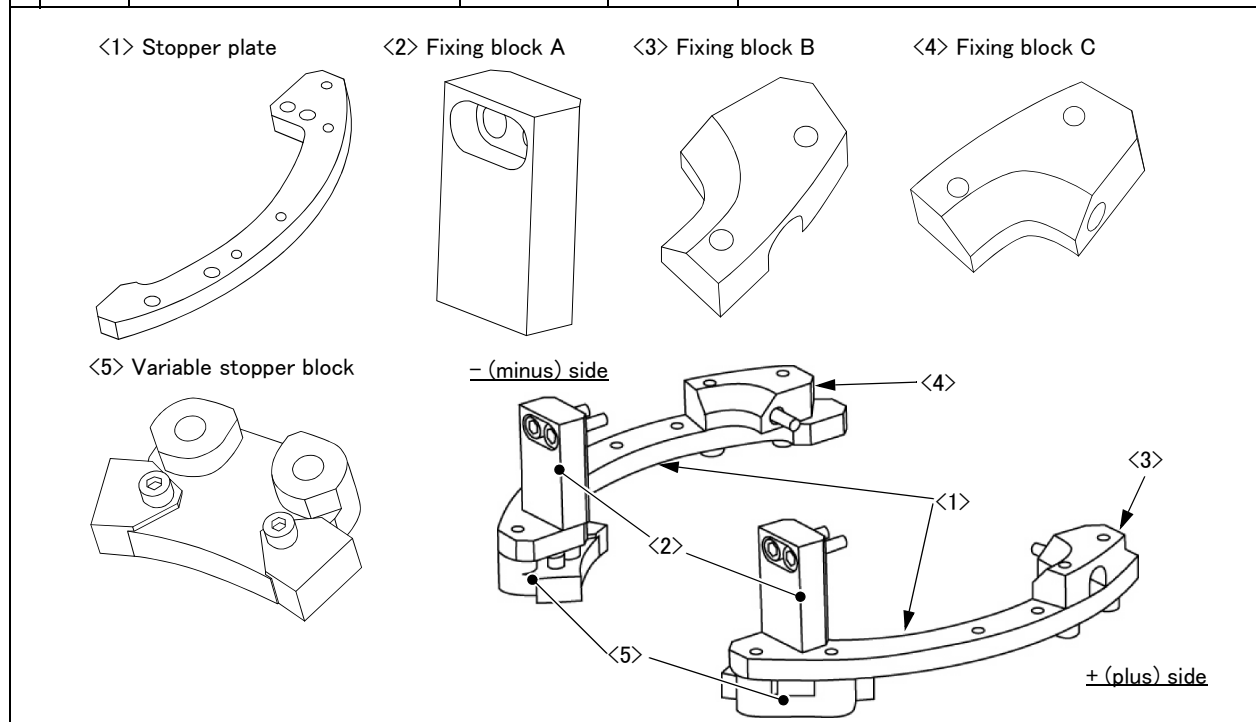

(2) Changeable angle

The changeable angle of RV-4FR series is shown in Table 3-8, and of RV-7FR series is shown in Table 3-9. Use as reference for the installation position of Variable stopper block to the wished angle and use/disuse of the Mechanical stopper screw A/B and the parameter setup value.

Table 3-8 : Changeable angle (RV-4FR series)

Item	Standard	Changeable angle (combination of + side/- side) (Unit: Degree)			
+ (plus) side	+240	+30	+73	+103	+146
Variable stopper block angle	-	+33	+76	+106	+149
Variable stopper block position ^{Note1)}	-	(a)	(b)	(a)	(b)
Mechanical stopper screw A ^{Note2)}	-	Use		Disuse ^{Note3)}	
Parameter (MEJAR) setting value	+240	+30	+73	+103	+146
+ (minus) side	-240	-30	-73	-103	-146
Variable stopper block angle	-	-33	-76	-106	-149
Variable stopper block position ^{Note1)}	-	(d)	(c)	(d)	(c)
Mechanical stopper screw B ^{Note2)}	-	Use		Disuse ^{Note3)}	
Parameter (MEJAR) setting value	-240	-30	-73	-103	-146

Note1)Symbol: “(a)” – “(d)” in Table 3-8 is related with the symbol of “Fig. 3-3: Installation image of J1axis operating range change option (RV-4FR/7FR series)”.

Note2)In the table, it means that “Disuse” does not install the screw, and “Use” does install the screw.

Note3)Mechanical stopper screw which is either one of the two is always necessary. For this reason, the combination enclosed by the thick line of the square in the table (both of + (plus) side and - (minus) side are 103 or 146) cannot be used.
Example) Setting + 146 degree and -103 degree simultaneously cannot be used. The other combination can be set up.

Table 3-9 : Changeable angle (RV-7FR series)

Item	Standard	Changeable angle (combination of + side/- side) (Unit: Degree)			
+ (plus) side	+240	+35	+77	+99	+141
Variable stopper block angle	-	+38	+80	+102	+144
Variable stopper block position ^{Note1)}	-	(a)	(b)	(a)	(b)
Mechanical stopper screw A ^{Note2)}	-	Use		Disuse ^{Note3)}	
Parameter (MEJAR) setting value	+240	+35	+77	+99	+141
+ (minus) side	-240	-35	-77	-99	-141
Variable stopper block angle	-	-38	-80	-102	-144
Variable stopper block position ^{Note1)}	-	(d)	(c)	(d)	(c)
Mechanical stopper screw B ^{Note2)}	-	Use		Disuse ^{Note3)}	
Parameter (MEJAR) setting value	-240	-35	-77	-99	-141

Note1)Symbol: “(a)” – “(d)” in Table 3-9 is related with the symbol of “Fig. 3-3: Installation image of J1axis operating range change option (RV-4FR/7FR series)”.

Note2)In the table, it means that “Disuse” does not install the screw, and “Use” does install the screw.

Note3)Mechanical stopper screw which is either one of the two is always necessary. For this reason, the combination enclosed by the thick line of the square in the table (both of + (plus) side and - (minus) side are 99 or 141) cannot be used.
Example) Setting + 141 degree and -99 degree simultaneously cannot be used. The other combination can be set up.

The installation procedure of the J1 axis operating range change is shown below.

When installing this option to the minus side, should move the J1 axis to the +70 degrees using jog operation previously, and do this work.

[Note] When installing this option for safety, you should cut off the power supply of the controller.

Surely fix the screw of M6 by 15.7Nm, and the screw of M10 by 26.5Nm. Please confirm having surely fixed by correct torque before moving the robot. Although the following shows the procedure installed to +(plus) side, -(minus) side is the same also.

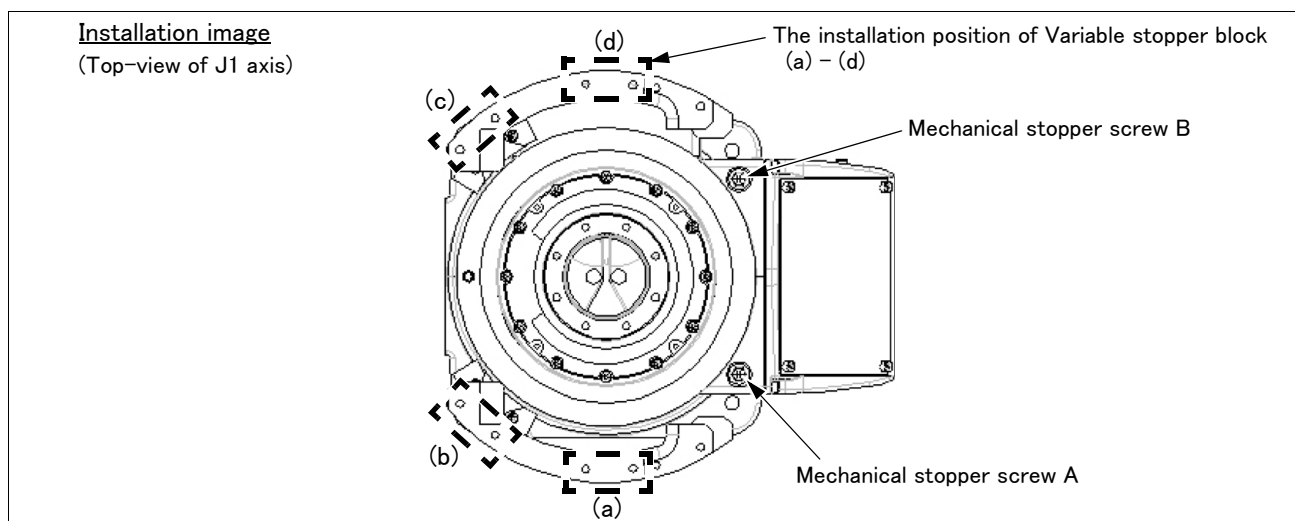

Fig.3-3 : Installation image of J1axis operating range change option (RV-4FR/7FR series)

[Example] In the RV-7FR series, when limiting the +side to +35 degree, and the -side to -141 degree, install as following.

Variable stopper block: Installs in the position of (a), and the position of (c).

Mechanical stopper screw A: Install.

Mechanical stopper screw B: Do not install.

(3) Installation procedure

The installation procedure of the J1 axis operating range change is shown below.

When installing this option to the minus side, should move the J1 axis to the +70 degrees using jog operation previously, and do this work.

CAUTION

When installing this option for safety, you should cut off the power supply of the controller.

Surely fix the screw of M6 by 15.7Nm, and the screw of M10 by 26.5Nm. Please confirm having surely fixed by correct torque before moving the robot.

Although the following shows the procedure installed to +(plus) side, -(minus) side is the same also.

- 1) Fix the Fixing block A <2> and the Fixing block B <3> to the robot arm as temporary.
Fix the Fixing block A <2> by using the two screws <8>, and fix the Fixing block B <3> by using a screw <7>.

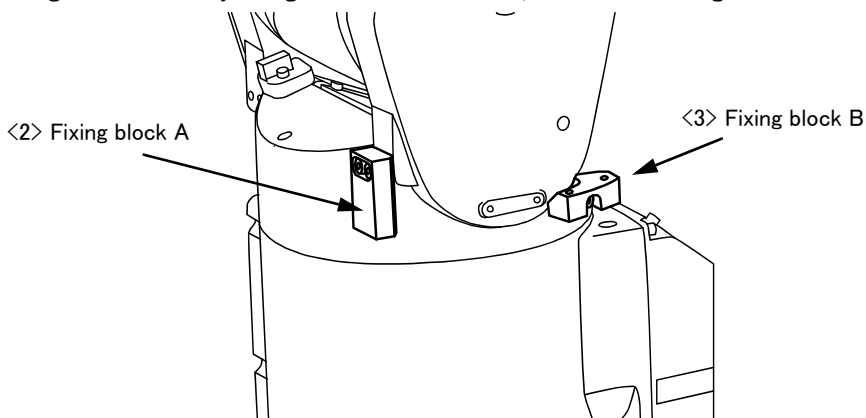

- 2) Install the Stopper plate <1>. Install by using each two screws (RV-4FR: screw <8>, RV-7FR: screw <7>), adjusting the combination position of the Fixing block A <2> and the Fixing block B <3>. Finally fix <1>,<2>,<3> securely.

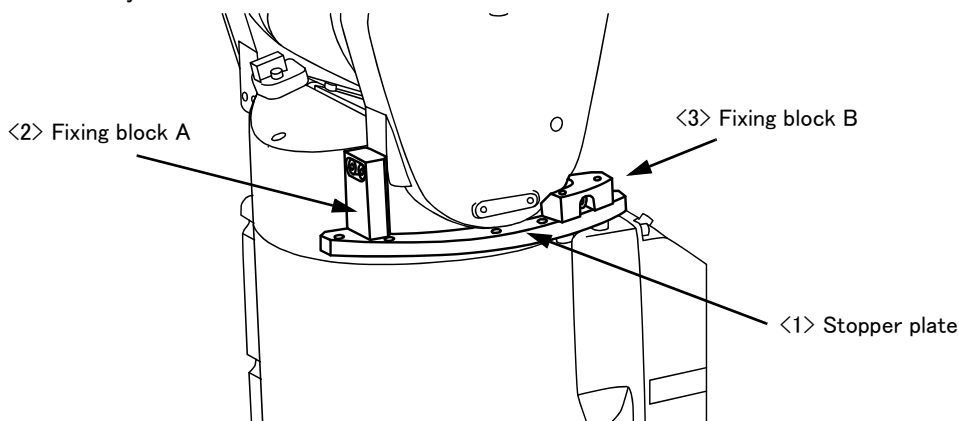

- 3) Install the Variable stopper block <5> by using two screws (RV-4FR: screw <8>, RV-7FR: screw <7>). There are two installation positions in the +/- side respectively. Install to the position of the angle which limits the operating range with referring to [Table 3-8](#) and [Table 3-9](#). Install the minus side in the same way. Move the J1 axis to the +70 degrees using jog operation previously, and install. (Turn on the power supply and move the J1 axis by jog operation) After installation, turn on the power supply and move the J1 axis to the 0 degree by jog operation.

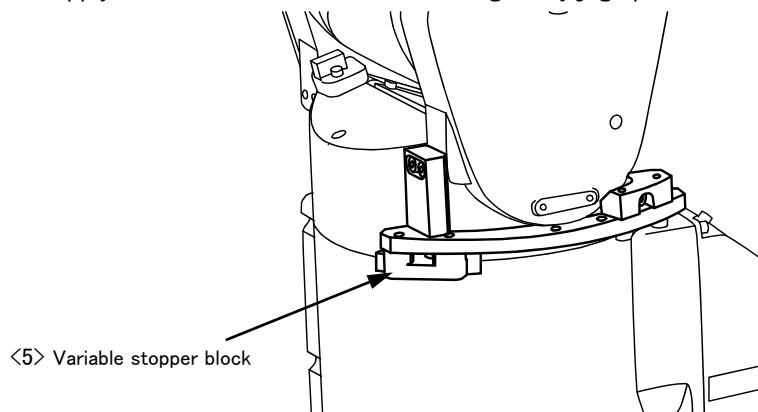

- 4) Install the Mechanical stopper screw A or B. Install the necessary screw with referring to [Table 3-8](#) and [Table 3-9](#).

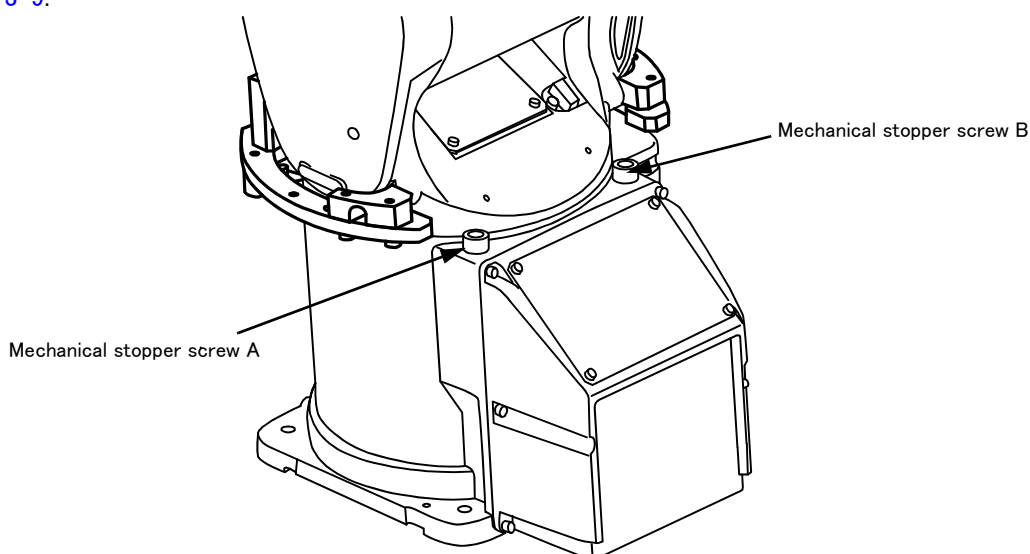

(4) Setting the parameter

Specify the operating range to parameters MEJAR with appropriate values (variable angles given in [Table 3-8](#) or [Table 3-9](#)) by the following steps.

- 1) Turn on the power supply.
- 2) Set up the operating range changed into parameter MEJAR.
MEJAR: (J1 minus (-) side, J1 plus (+) side, ***, ***, ***, ...).

Note) Refer to the separate "Instruction manual/Detailed Explanation of Functions and Operations" for the details of the setting method.

(5) Check the operating range

After changing the parameter, turn off the controller power and turn on again. And, move the axis changed by joint jog operation to the limit of the operating range. Confirm that the robot stops by limit over at the changed angle.

The changing of the operating range is completed.

3.2.2 RV-13FR series

(1) Configuration

The configuration parts of this option (1F-DH-05J1) are shown in Table 3-10. Please confirm.

Table 3-10 : Configuration devices

No.	Part name	Qty.	Mass (kg)	Remarks
<1>	Stopper Block J1	1	0.3	
<2>	Resin Stopper B	2		One piece each for + side/- side
<3>	Screw (M12 × 20)	2		Mechanical Stopper screw
<4>	Screw (M10 × 40)	2		For Stopper Block J1 fixing
<5>	Screw (M4 × 12)	4		For Resin Stopper B fixing

<1>Stopper Block J1
<2>Resin Stopper B

(2) Changeable

The changeable angle of RV-13FR series is shown in Table 3-11. Use as reference for the installation position of Mechanical Stopper screw and the parameter setup value.

Table 3-11 : Changeable angle (RV-13FR series)

Item	Standard	Changeable angle	
		(A)	(B)
+ (plus) side	+190	+30	+120
Mechanical Stopper screw position ^{Note1)}	-	(A)	(B)
Mechanical Stopper position	+193	+32.5	+122.5
Parameter (MEJAR) setting value	+190	+30	+120
+ (minus) side	-190	-30	-120
Mechanical Stopper screw position ^{Note1)}	-	(D)	(C)
Mechanical Stopper position	-193	-32.5	-122.5
Parameter (MEJAR) setting value	-190	-30	-120

Note1)Symbol: “(A)” – “(D)” in the Table 3-11 is related with the symbol of “Fig. 3-4: Installation image of J1axis operating range change option (RV-13FR series)”.

The installation procedure of the J1 axis operating range change is shown below.

[Note] When installing this option for safety, you should cut off the power supply of the controller.

Surely fix the screw of M4 by 15.7Nm, and the screw of M10 by 26.5Nm, and the screw of M12 by 26.5Nm. Please confirm having surely fixed by correct torque before moving the robot.

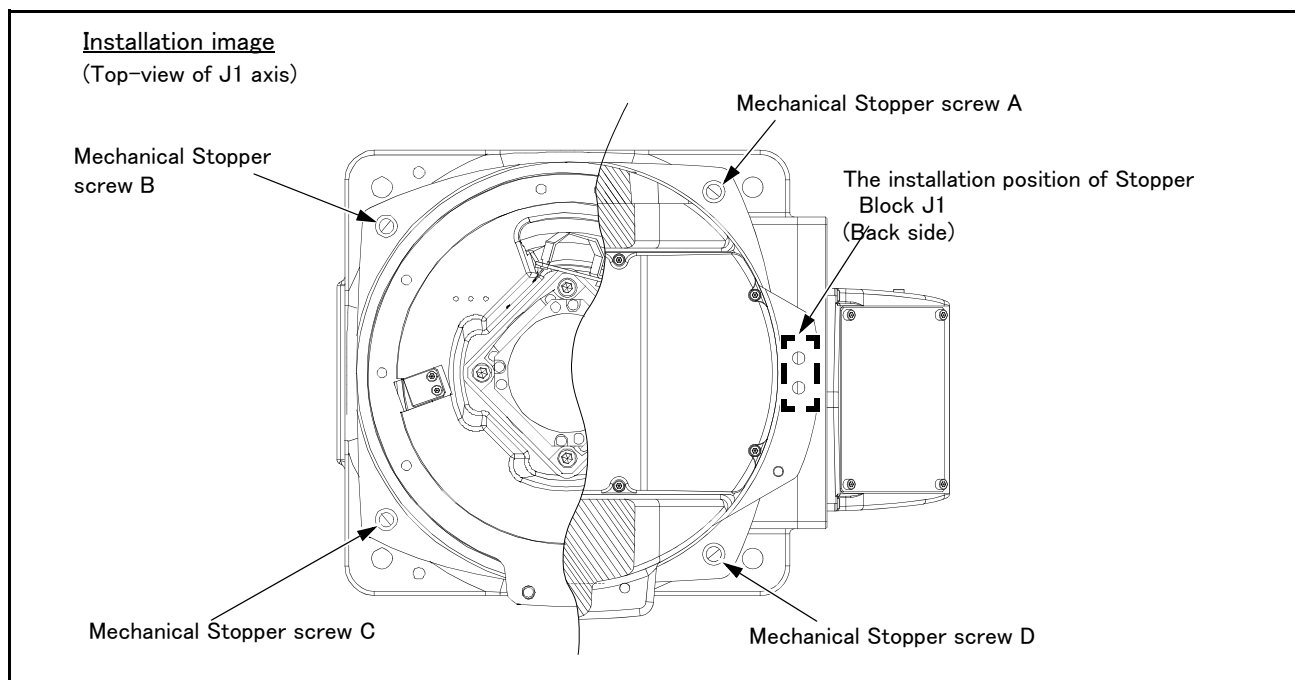

Fig.3-4 : Installation image of J1axis operating range change option (RV-13FR series)

[Example] In the RV-13FR series, when limiting + side to +32.5 degree and - side to -122.5 degree, install the Mechanical Stopper screw in the position of (A) and (C).

(3) Installation procedure

The installation procedure of the J1 axis operating range change is shown below.

[Note] Previously, move the J1 axis to the position of the +90 degrees or the -90 degrees by jog operation.

CAUTION

When installing this option for safety, you should cut off the power supply of the controller.

Surely fix the screw of M4 by 15.7Nm, and the screw of M10 by 26.5Nm, and the screw of M12 by 26.5Nm. Please confirm having surely fixed by correct torque before moving the robot.

Although the following shows the procedure installed to +(plus) side, -(minus) side is the same also.

- 1) Install <2> Resin Stopper B (two pieces) to the both sides of <1> Stopper Block J1 in with the two attached <5> screws, and fix securely.

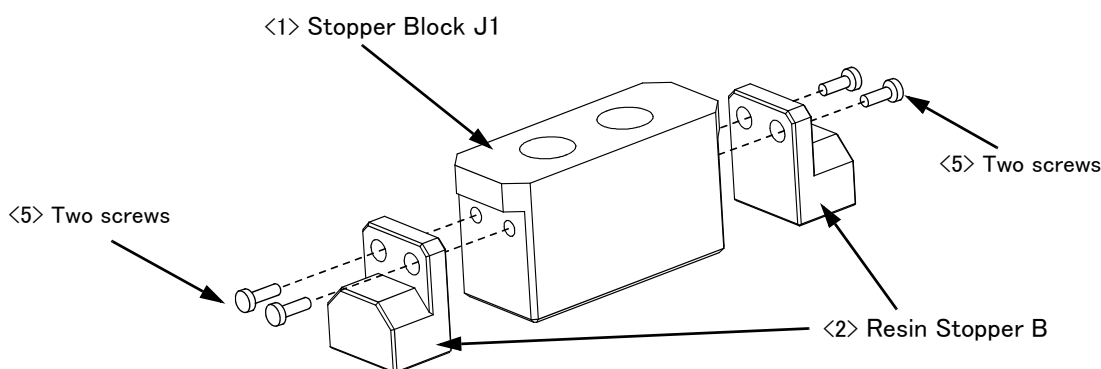

- 2) Install <1> Stopper Block J1 which combined with <2> Resin Stopper B to behind the J1 axis of robot arm by <4> two attached screws.

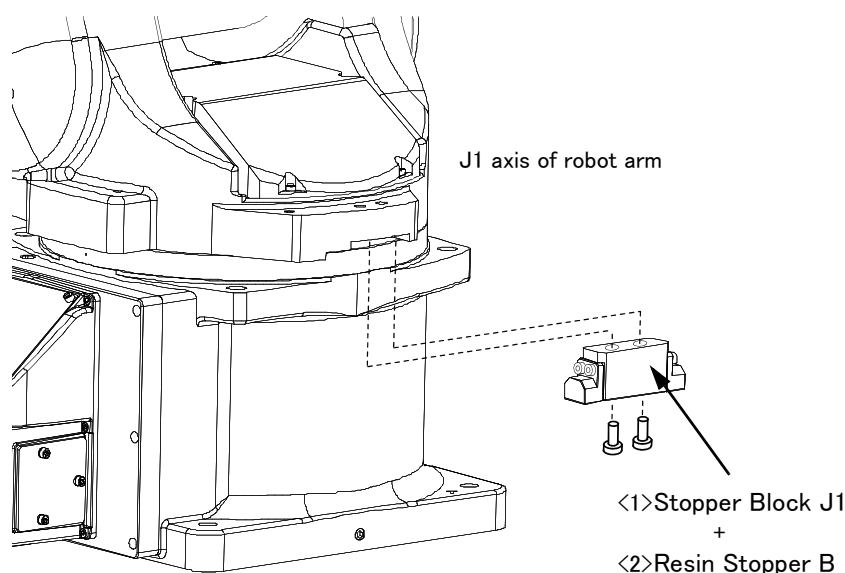

- 3) Because to install the Mechanical Stopper screw, once move the J1 axis to the position of 0 degree. Turn on the power supply and move the J1 axis by jog operation.

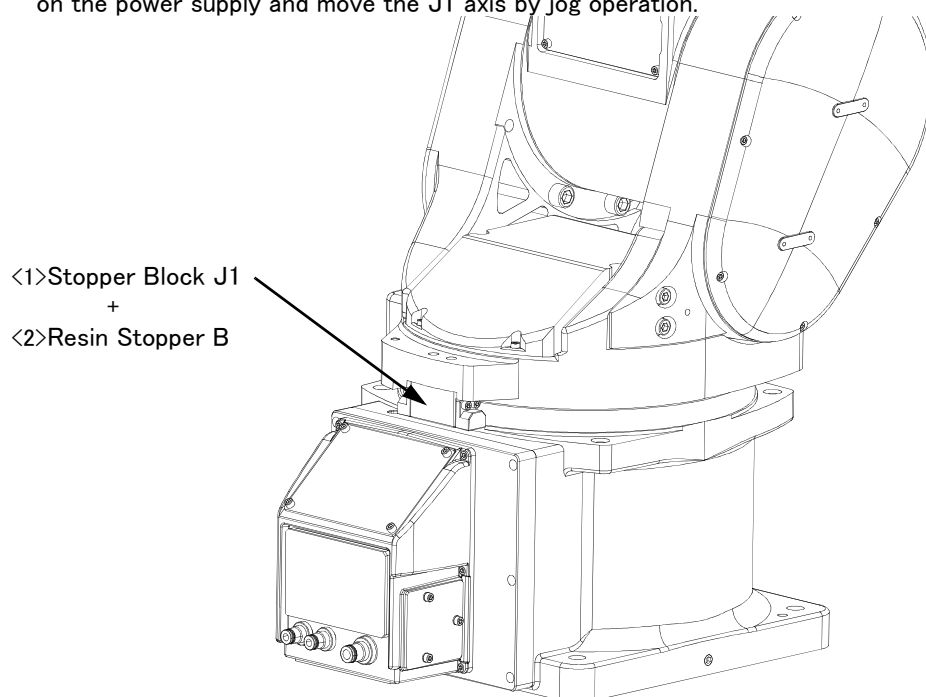

- 4) Install the <3> Mechanical Stopper screw. Install the <3> attached Mechanical Stopper screw to the needed point with referring to [Table 3-11](#) and [Fig. 3-4](#).

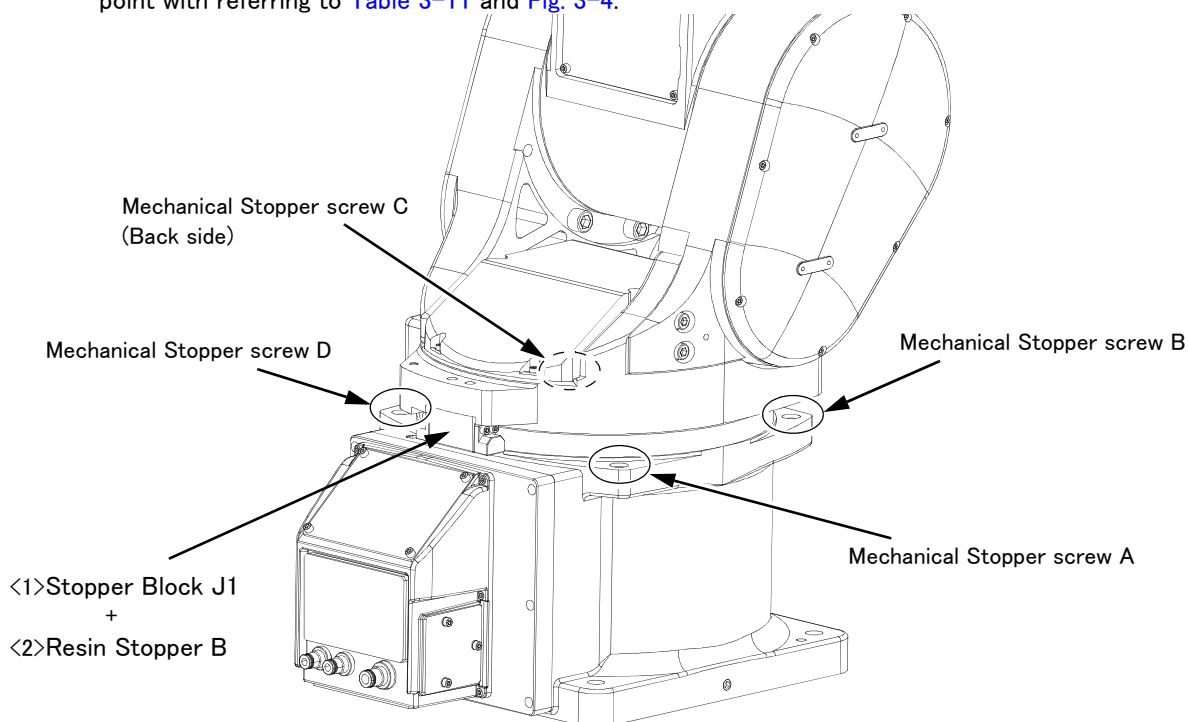

(4) Setting the parameter

Specify the operating range to parameters MEJAR with appropriate values (variable angles given in [Table 3-11](#)) by the following steps.

- 1) Turn on the power supply.
- 2) Set up the operating range changed into parameter MEJAR.
MEJAR: (J1 minus (-) side, J1 plus (+) side, ***, ***, ***, ...).

Note) Refer to the separate "Instruction manual/Detailed Explanation of Functions and Operations" for the details of the setting method.

(5) Check the operating range

After changing the parameter, turn off the controller power and turn on again. And, move the axis changed by joint jog operation to the limit of the operating range. Confirm that the robot stops by limit over at the changed angle.

The changing of the operating range is completed.

3.3 Installing the solenoid valve set

(1) RV-2FR series

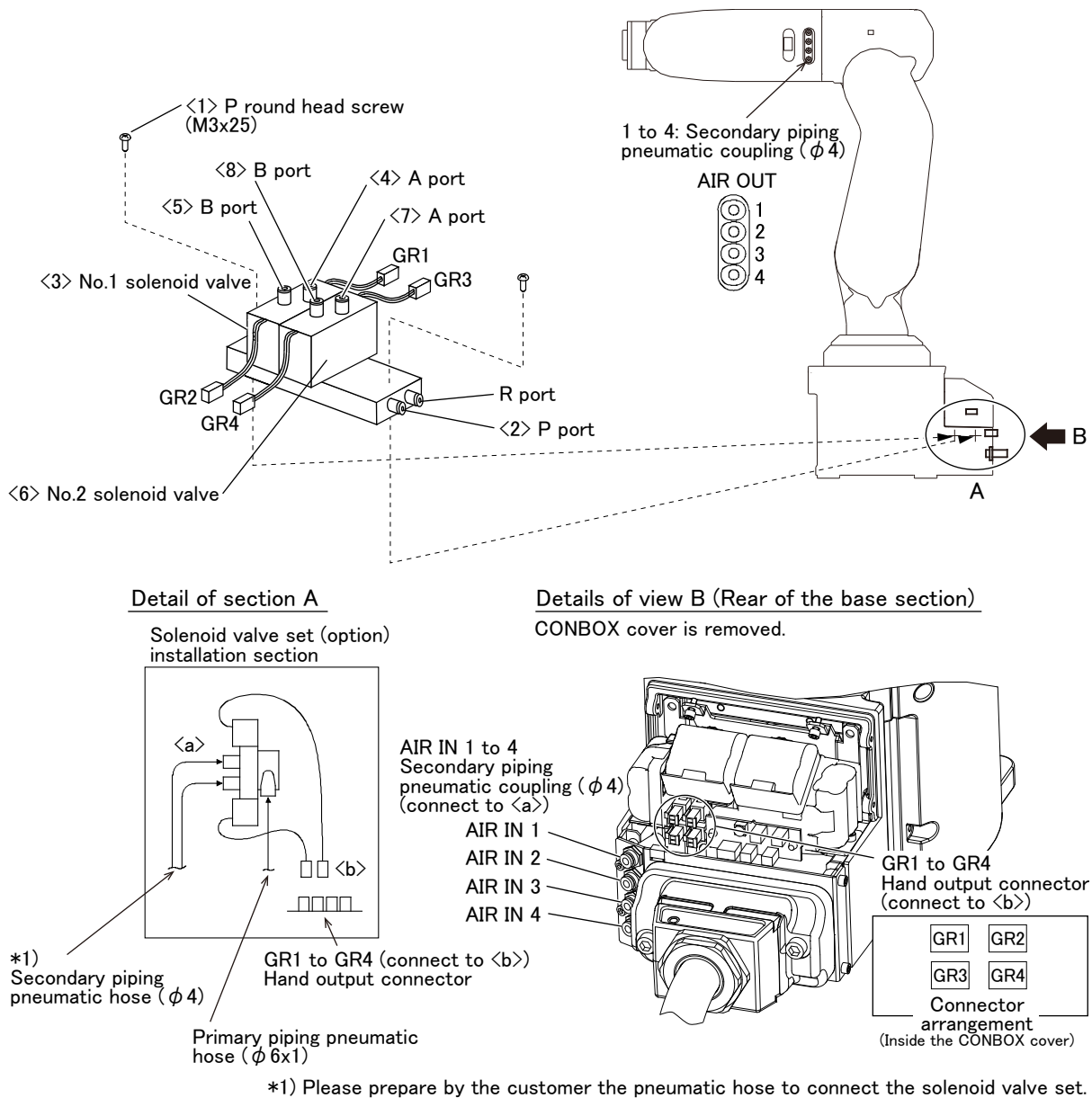

Fig.3-5 : Solenoid valve installation procedures

Fig. 3-5 shows the solenoid valve installation procedures and the solenoid valve connector connection procedures. The installation procedures are as follow. This work must be carried out with the controller power turned OFF. It is necessary to set the parameters (HIOTYPE, HANDYPE) in accordance with solenoid valve type (sink type/ source type) and output signal before using the solenoid valve set. Refer to the separate volume, "Instruction Manual/Detailed Explanations of Functions and Operations" for how to set parameters.

- 1) Using the screw holes on the base of the robot arm, install the solenoid valve with the enclosed screw <1> (M3 x 25: 2 screws).
- 2) Connect the primary air supply air hose ($\phi 6$, prepared by customer) to the quick joint (P port) <2> of the solenoid valve.

- 3) Connect the AIR IN "1" mark secondary piping coupler to the A port <4> of the No. 1 solenoid valve <3> with an air hose (ϕ 4 approx. 250mm, prepared by customer.)
In the same manner, connect the AIR IN "2" mark secondary piping coupler to the B port 5 of the No. 1 solenoid valve.
For a double valve (1E-VD02), connect the following:
Connect the AIR IN "3" mark secondary coupler to the A port <7> of the No. 2 solenoid valve <6>.
Connect the AIR IN "4" mark secondary coupler to the B port <8> of the No. 2 solenoid valve <6>.
- 4) Refer to [Page 103, "5.3.2 Installing/removing the cover"](#), and remove the CONBOX cover.
Connect the GR1 plug from the No. 1 solenoid valve <3> to the GR1 connector on the back of the robot arm.
Connect the GR2 plug from the No. 1 solenoid valve <3> to the GR2 connector on the back of the robot arm.
For a double valve (1E-VD02), connect the following:
Connect the GR3 plug from the No. 2 solenoid valve <6> to the GR3 connector on the back of the robot arm.
Connect the GR4 plug from the No. 2 solenoid valve <6> to the GR4 connector on the back of the robot arm.

3.3.1 RV-4FR/7FR series, RV-7FRLL

As shown in [Fig. 3-6](#), install the solenoid valve set on the forearm.

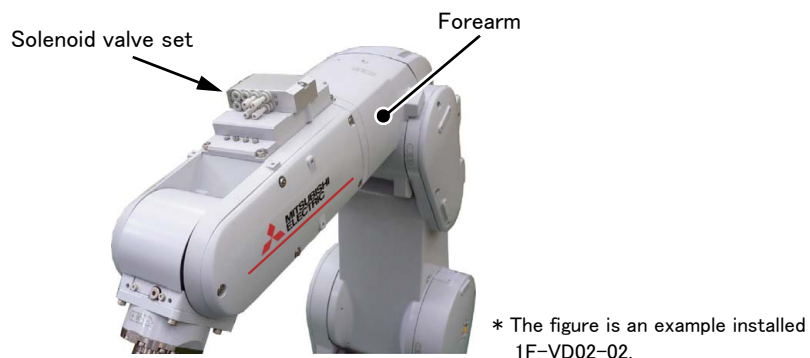

Fig.3-6 : The installation image of the optional solenoid valve set (RV-4FR series)

The installation procedure of solenoid valve set depends on robot series and specifications. Refer to the explanation section corresponding to the robot which uses and install the solenoid valve set properly.

It is necessary to set the parameters (HIOTYPE, HANDYPE) in accordance with solenoid valve type (sink type/source type) and output signal before using the solenoid valve set.

Refer to the separate volume, "Instruction Manual/Detailed Explanations of Functions and Operations" for how to set parameters.

<Explanation section for each type of robot >

- RV-4FR/7FR series and RV-7FRLL robots: Refer to [Page 70](#), "(1) RV-4FR/7FR series, RV-7FRLL".
- RV-13FR/13FRL and RV-20FR robots: Refer to [Page 79](#), "(2) RV-13FR/13FRL, RV-20FR".

(1) RV-4FR/7FR series, RV-7FRLL

This paragraph explains how to install the solenoid valve set to RV-4FR/7FR series and RV-7FRLL robots. (The solenoid valve set of 1F-VD04-02 is used as an example.)

Turn the controller's power OFF before this installing operation.

In addition, an instruction is described based on internal wiring and piping specification. Refer only to the required section for standard specification.

Moreover, please prepare the following furnished accessory.

Robot arm accessory (only internal wiring and piping specification)

* The numbers of attached couplings and air hoses depends on the robot specifications. In the shown example, four sets of couplings and four hoses are used.

Coupling front side(φ 4) φ 4 air hose

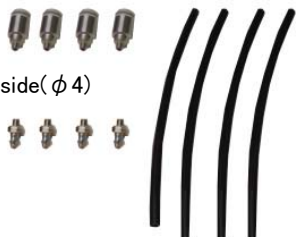

Coupling back side(φ 4)



Solenoid-valve set attachments

* Three elbow couplings are attached.



<Type name of elbow coupling>
 Maker: SMC Corporation
 Name: Plug-in elbow
 Model: KQ2L06-99A

1) Removes the plug on the solenoid valve and installs the coupling. (only internal wiring and piping specification)

Remove the plug of the position to use as shown in the figure.

Install the attached coupling for front side (φ 4 front side) in the screw hole which removed the plug. Turn the solenoid valve set over and install the back side coupling in the same way.

<Before attaching the couplings>

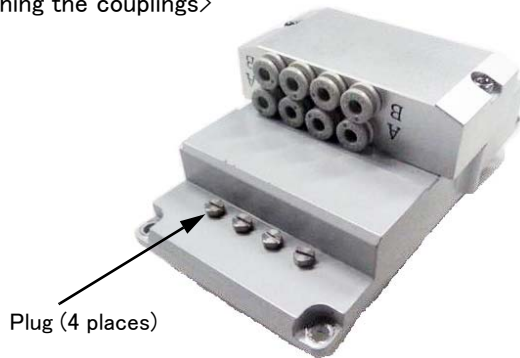

<After attaching the couplings>

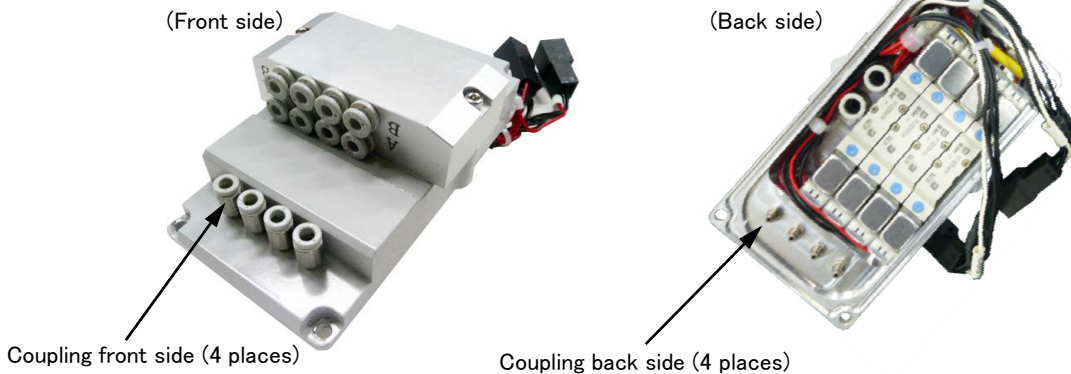

* The figure is an example which connected the first and second solenoid valve.

- 2) Installs the air hose. (only internal wiring and piping specification)
 Connects the port A/B of solenoid valve to use and the coupling on the front side installed by above-mentioned "1" with air hoses ($\phi 4$).



* The figure is an example which connected the first and second solenoid valve.

- 3) Loosen the fixing screws (M4x12) and detach the No.2 arm cover U (forearm upside) and the No.2 arm cover L (forearm side face). (standard/internal wiring and piping specification common)
 The connectors (GR1, GR2), $\phi 4$ secondary piping air hoses (4), and the AIR IN ($\phi 6$, white) and RETURN ($\phi 6$, black) primary piping air hoses are set inside the forearm.

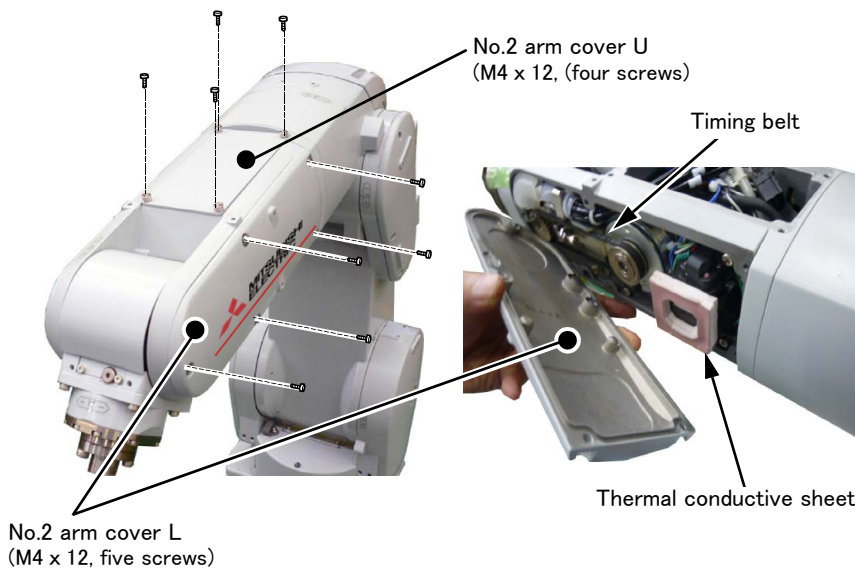

CAUTION

The thermal conductive sheet is adhered closely to the No.2 arm cover L. To prevent the thermal conductive sheet from coming off, detach the cover slowly and firmly. When the sheet comes off, reattach it to the original position.

CAUTION

After the cover is removed, take care not to damage the thermal conductive sheet or timing belt.

Forearm top

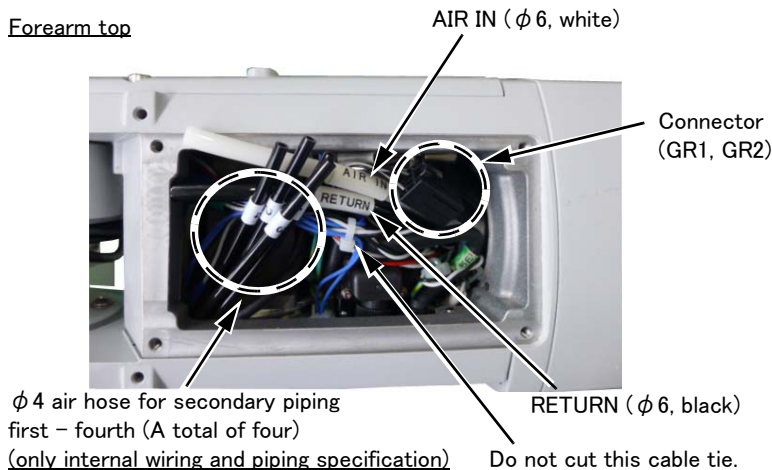

CAUTION

Take sufficient care to prevent foreign matters (cut chips of air hoses, etc.) from entering the robot.

CAUTION

Do not cut the cable tie that bundles the cables inside the arm. Doing so may loosen the fixed cables, resulting in interference with the timing belt.

- 4) Cut the $\phi 4$ secondary piping air hoses. (only internal wiring and piping specification)
Cutting the $\phi 4$ secondary piping air hoses facilitates connection to the solenoid valve.

CAUTION Securely cut and connect the air hose to a surely suitable length.
Failure to observe this could lead to the air hose breaks within an arm, and a solenoid valve becomes the cause of not operating to a normality.

- Align the $\phi 4$ secondary piping air hoses from No.1 to No.4 on the No.2 arm cover side as shown in the figure.

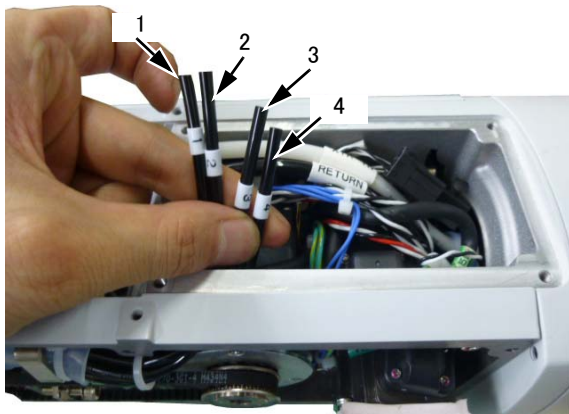

- Apply the scale to the arm lower end on the No.2 arm cover L side, and measure the length, then mark and cut the hose.
- Cut the air hose vertically in the lengthwise direction of the air hose with a dedicated cutter. If the cut end is not vertical, it causes air leakage.

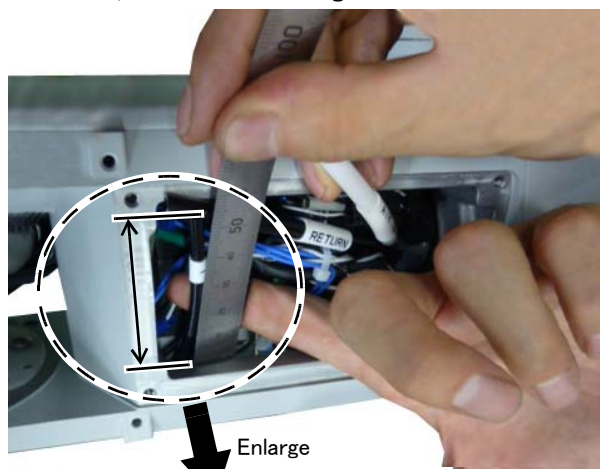

<Cutting dimension guide>

- 1: 50-55mm
- 2: 45-50mm
- 3: 40-45mm
- 4: 35-40mm

CAUTION

Take sufficient care to prevent foreign matters (cut chips of air hoses, etc.) from entering the robot.

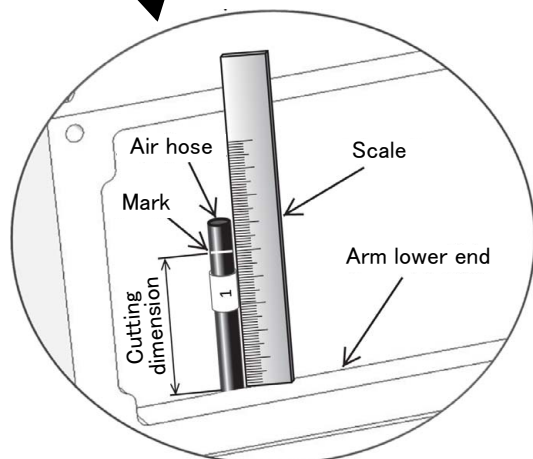

- 5) Cut the $\phi 6$ primary piping air hoses. (standard/internal wiring and piping specification common)
 To facilitate connection to the solenoid valve, measure the length of $\phi 6$ primary piping air hoses (AIR IN and RETURN) from the end of rubber sheet at the base of the air hoses before cutting

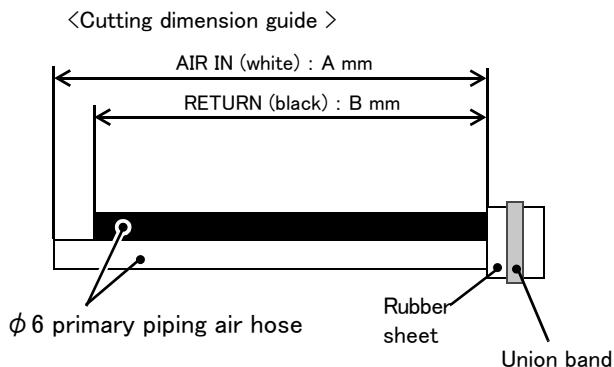
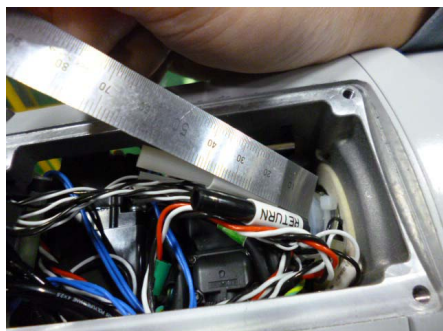

CAUTION

Take sufficient care to prevent foreign matters (cut chips of air hoses, etc.) from entering the robot.

Cutting dimension guide A, B

(Unit: mm)

Robot	Dimension A (AIR IN)	Dimension B (RETURN)
RV-4FR	60	35
RV-4FRL/7FR/7FRL/7FRLL series	70	45

- 6) Attach the elbow coupling and check the positions for connection. (standard/internal wiring and piping specification common)
 a) Attach the elbow couplings which attached the solenoid valve set to the $\phi 6$ primary piping air hoses (one for AIR IN, two for RETURN).

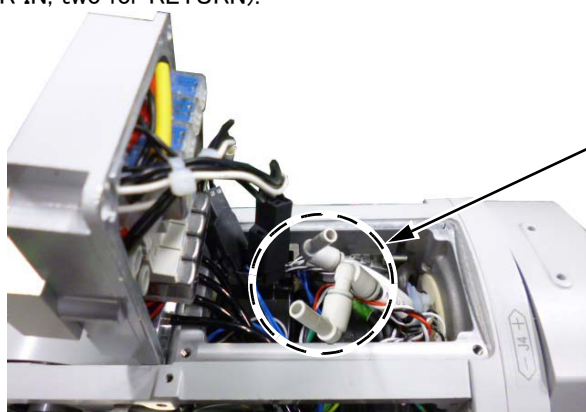

Attach the elbow couplings to the AIR IN (white) and RETURN (black) air hoses. Two elbow couplings are made to connect with the air hose of RETURN (black) to a series.

- b) Check the position for connecting the couplings.
 Measure the dimensions from the end of machined surface which install the solenoid valve to the end of elbow coupling.
 If the Length of an air hose is unsuitable, please cut again and adjust.

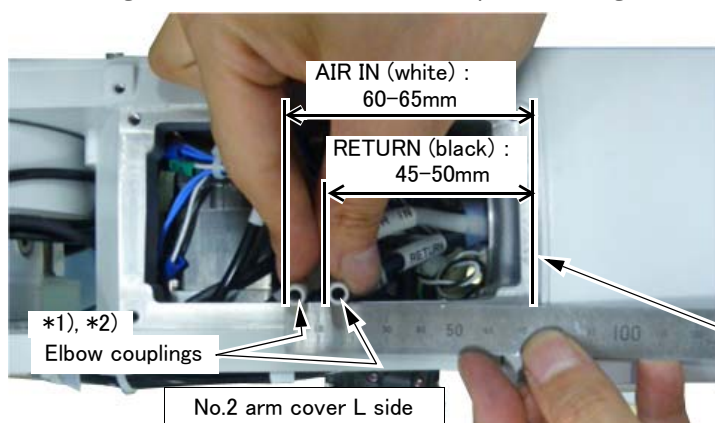

*1) To facilitate connection to the solenoid valve, attach the elbow couplings to face upward.

*2) Before measuring the dimensions, press the elbow couplings against the No.2 arm cover L side end face. Also, check that the air hoses are not bent in the area specified in the figure.

machined surface which install the solenoid valve

- 7) Connect the $\phi 4$ secondary piping air hoses. (only internal wiring and piping specification)
 Connect the $\phi 4$ secondary piping air hoses to the couplings on the back side of the solenoid valve.
 Connect the air hoses sequentially from No.1.

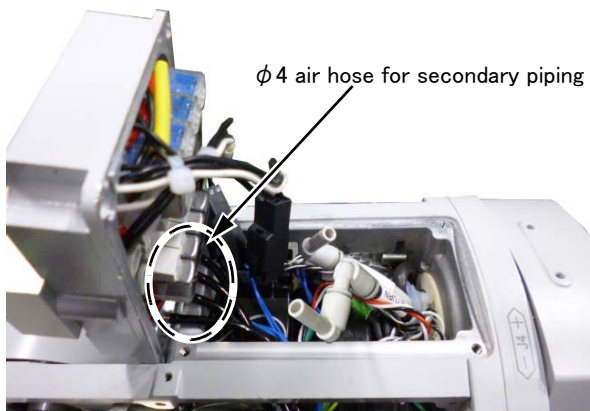

<Enlarged view of the $\phi 4$ air hose connection area>

Couplings on the back side of the solenoid valve

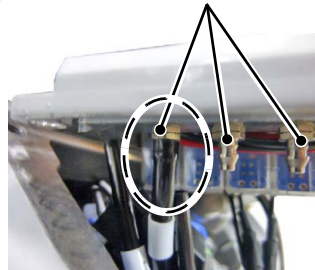

Push the $\phi 4$ secondary piping air hoses firmly to the base of couplings as shown in the figure.

The numbers (No.1 to No.4) indicated on the $\phi 4$ secondary piping air hoses are consistent with the numbers of piping pulled out of the mechanical interface. Refer to the numbers for piping to the tool.
 As an example of the tools, Table 3-12 shows the relation between hand condition and coupling port number.

Table 3-12 : Solenoid valve ports and hand number

Hand	Hand condition	Port number	The solenoid valve set in use
Hand 1	OPEN	1	One set
	CLOSE	2	
Hand 2	OPEN	3	Two sets
	CLOSE	4	
Hand 3	OPEN	5	Three sets
	CLOSE	6	
Hand 4	OPEN	7	Four sets
	CLOSE	8	

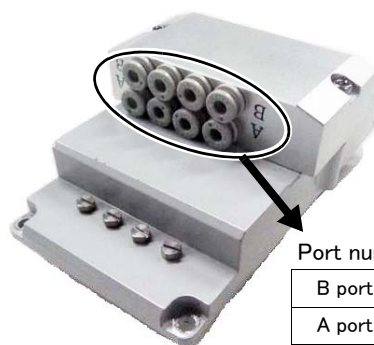

B port	2	4	6	8
A port	1	3	5	7

- 8) Connect the connector. (standard/internal wiring and piping specification common)
- a) To prevent the lead wire from being put, checks that the lead wire which has come out of the solenoid valve is stored inside a solenoid-valve set as shown in a figure. If that is not right, store as shown in a figure.

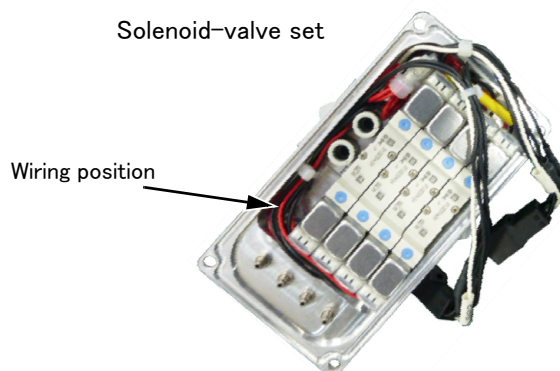

- b) Connects the hand output cable inside the forearm (GR1 and GR2) to the connectors of the solenoid-valve set.

Note) In the solenoid-valve set of one set or two sets, connects only connector GR1.

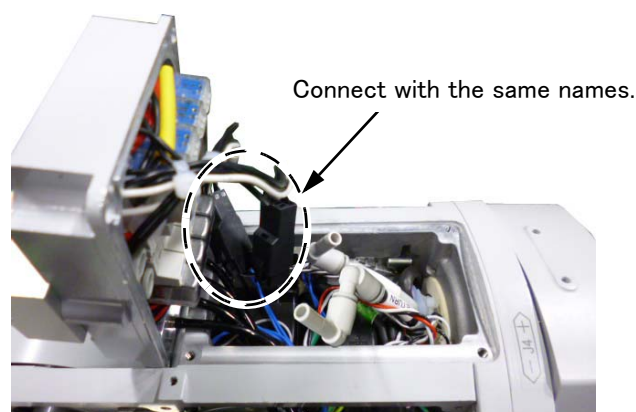

- c) Store the connected connectors in the positions shown in the figure below.

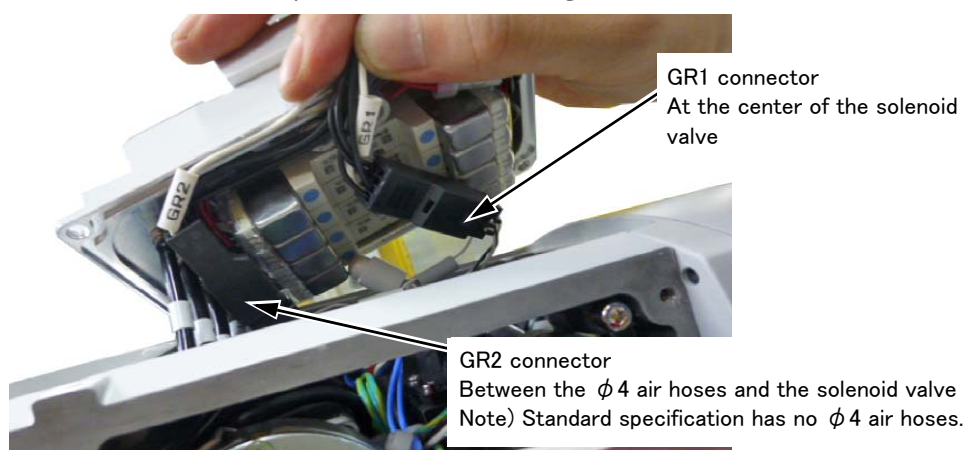

- 9) Connect the elbow couplings to the solenoid valve set. (standard/internal wiring and piping specification common)
 First, connect the elbow couplings for AIR IN (white) to the "P" port, and then connect the elbow couplings for RETURN (black) to the "R" port.

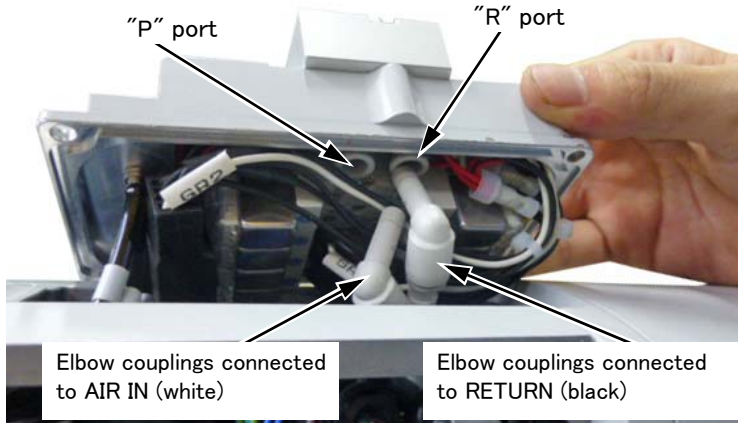

Note) The lead wire should be wired inside elbow couplings to prevent inserting the cable as shown in a figure

<Connection and adjustment of the elbow couplings>

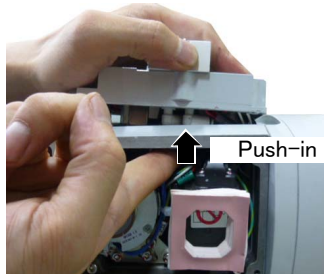

As shown in the above figure, push in the elbow couplings from the No.2 arm cover L side to improve workability.

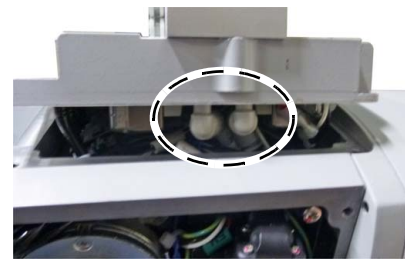

As shown in the above figure, adjust the direction of elbow couplings connected to AIR IN (white) and RETURN (black) as cross the solenoid valve to improve workability.

CAUTION When connecting the RETURN air hose, be sure to remove the dust cap attached at the RETURN coupling on the robot base section. If the cap is not removed, exhaust air pressure will increase and the solenoid valve may not operate properly. By connecting the exhaust air hose ($\phi 6$: customer preparation) to this RETURN air coupling, exhaust air from the solenoid valve is able to escape to the designated point.

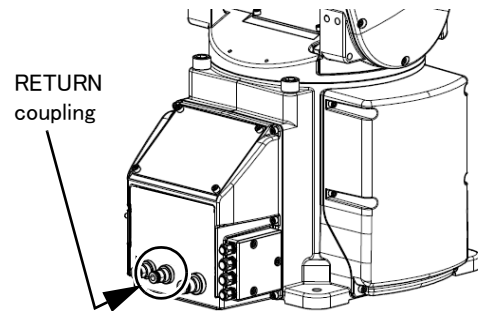

CAUTION When removing the solenoid valve set, remove it slowly with care. Strong pulling may cause damage of the joint or the piping air hose connected to the solenoid valve.

10) Install the solenoid valve set to the forearm. (standard/internal wiring and piping specification common)

Install the solenoid valve set to the forearm and match their positions. Take care not to put air hoses or cables between them.

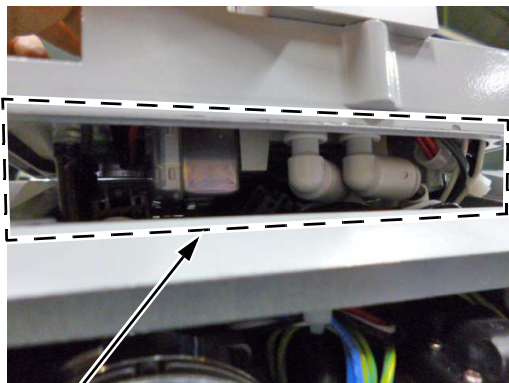

Visually check that the cables and air hoses are not pinched, and the air hoses are not bent.

Forearm top



The solenoid valve is installed to the shaded area. To prevent cables from being pinched, push the cables into the forearm and avoid placing any cable on the shaded area.

<Adjustment of piping layout of $\phi 4$ secondary piping air hoses> (only internal wiring and piping specification)

Side of robot

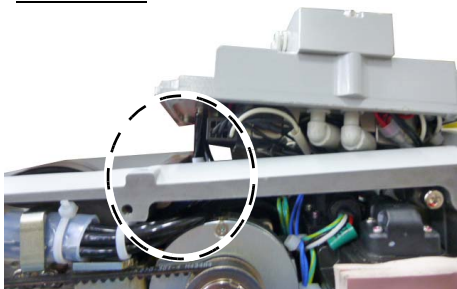

Top of robot

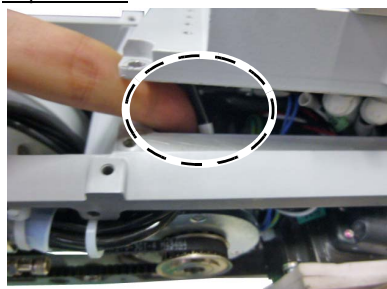

Push in the $\phi 4$ secondary piping air hose (No.4) with a finger from the No.2 arm cover L side or No.2 arm cover U side. Draw the hose around the motor upper surface to prevent it from being bent.

<Confirmation method of cable storage condition>

Check that the solenoid-valve set is pressed down by hand and there is no gap in the installation surface. If there is a gap the cable may not be correctly stored, please check again.

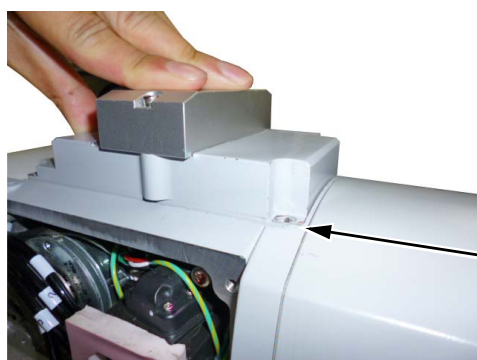

Check that there is no gap.

⚠ CAUTION

When you install the solenoid valve set, be careful to not put the cable and air hose between the cover and arm and do not break the air hose.

If the cable is inserted, it will become the cause that the cable or solenoid valve cover be broken. And, if the air hose is put or it breaks, it becomes the cause that the solenoid valve operation is abnormal.

- 11) Installs the solenoid valve set on the forearm upside. (standard/internal wiring and piping specification common)
 Firmly fix the solenoid valve set using the original fixing screws of the No.2 arm cover U. (Tightening torque: 1.39–1.89N · m).
 Then, from the No.2 arm cover L side, check that the air hoses in the forearm are not bent.

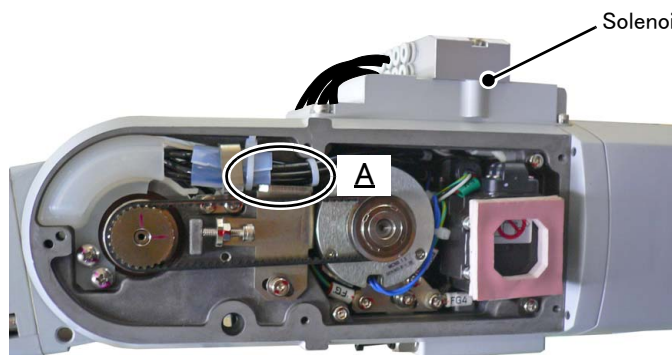

CAUTION Keep the air hoses from interfering with the moving parts of timing belt and its pulley. (See the area A.) Otherwise, air leakage may occur.

- 12) Install the No.2 arm cover L to the forearm. (standard/internal wiring and piping specification common)
 Install attached plugs to the port A/B couplings that are not used for the solenoid valve set.

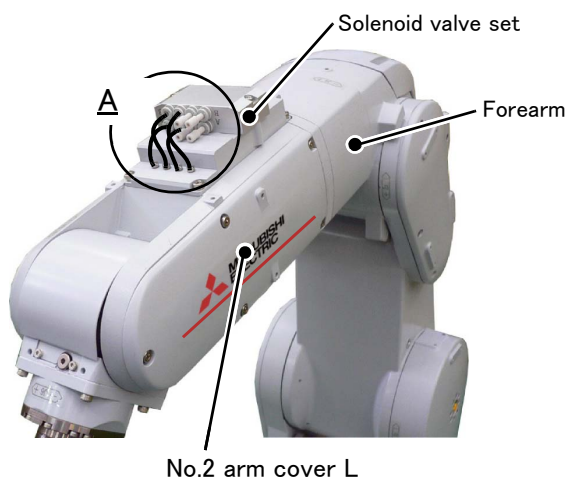

Enlarged view of section A

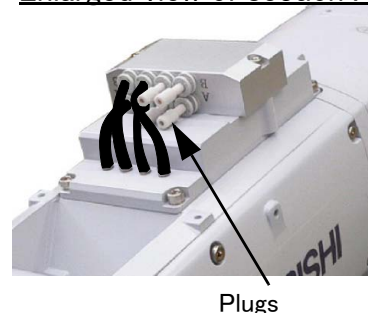

- 13) Connect the tool prepared by the customer with solenoid valve port A and B. (standard/internal wiring and piping specification common)
 When you use the standard specification robot, please prepare the air hoses for connection.
 Table 3-13 shows the relation between hand condition and port number.

Table 3-13 : Solenoid valve ports and hand number

Hand	Hand condition	Port number	The solenoid valve set in use
Hand 1	OPEN	1	One set
	CLOSE	2	
Hand 2	OPEN	3	Two sets
	CLOSE	4	
Hand 3	OPEN	5	Three sets
	CLOSE	6	
Hand 4	OPEN	7	Four sets
	CLOSE	8	

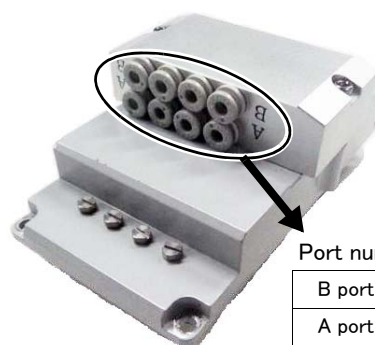

Port number

B port	2	4	6	8
A port	1	3	5	7

The installing of the solenoid valve set is completed.

(2) RV-13FR/13FRL, RV-20FR

Install the solenoid valve set on the forearm.

The installation procedure of solenoid valve set depends on robot series and specifications. Refer to the explanation section corresponding to the robot which uses and install the solenoid valve set properly.

This paragraph explains how to install the solenoid valve set to RV-13FR/13FRL and RV-20FR robots. (The solenoid valve set of 1F-VD04-03 is used as an example.)

Turn the controller's power OFF before this installing operation.

In addition, an instruction is described based on internal wiring and piping specification. Refer only to the Required section for standard specification

1) Removes a bolt and installs the coupling. (only internal wiring and piping specification)

- a) Remove bolts, nuts and seal washers that were fixed on the optional solenoid valve set. To do this, remove the bolts attached the position to use as shown in the figure.
- b) Attach a bulkhead coupling to the hole. The bulkhead couplings are one of the attachments of robot arm. Remove one of lock nuts, width across flats: 11mm, from a bulkhead coupling, and attach the bulkhead coupling to the hole.
- c) Fasten firmly with the removed lock nut.

<Before attaching the couplings>

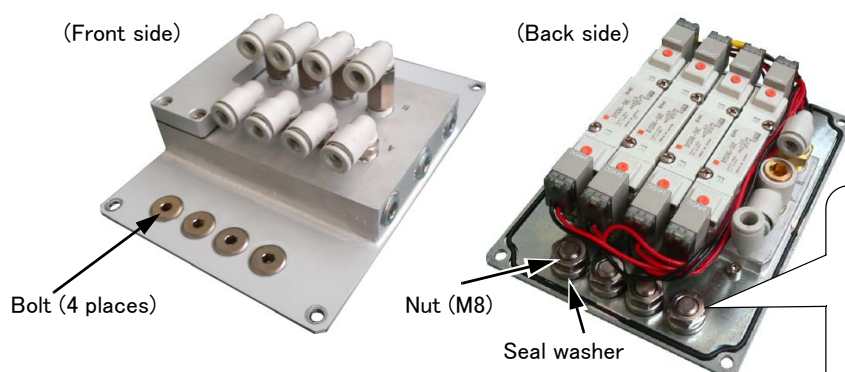

Note) When removing a bolt from a hole, push the tip of the bolt after removing a nut.

<After attaching the couplings>

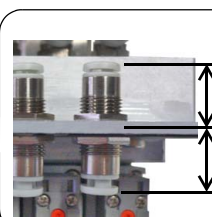
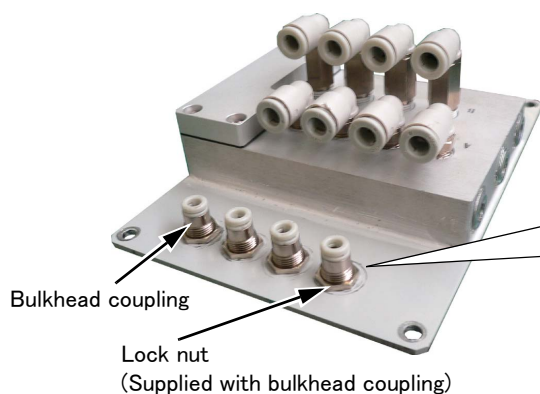

Note) When installing a bulkhead coupling, install in the middle position of the coupling.

* The figure is an example which connected the first and second solenoid valve.

2) Installs the air hose. (only internal wiring and piping specification)

Install attached conversion couplings ($\phi 6$ to $\phi 4$) to the port A/B on the solenoid valve.

Then, connects the port A/B of solenoid valve to use and the coupling on the front side installed by above-mentioned "1)" with air hoses ($\phi 4$).

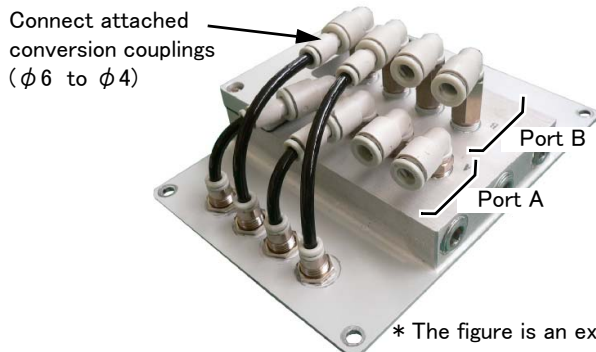

- 3) Loosen the four fixing screws of No.2 arm cover U (forearm upside) and remove the cover. (standard/internal wiring and piping specification common)
 (Mounts the solenoid-valve set instead of the removed cover) The connectors (GR1, GR2) and air hoses (AIR IN, RETURN) connected to the solenoid-valve set inside the cover.

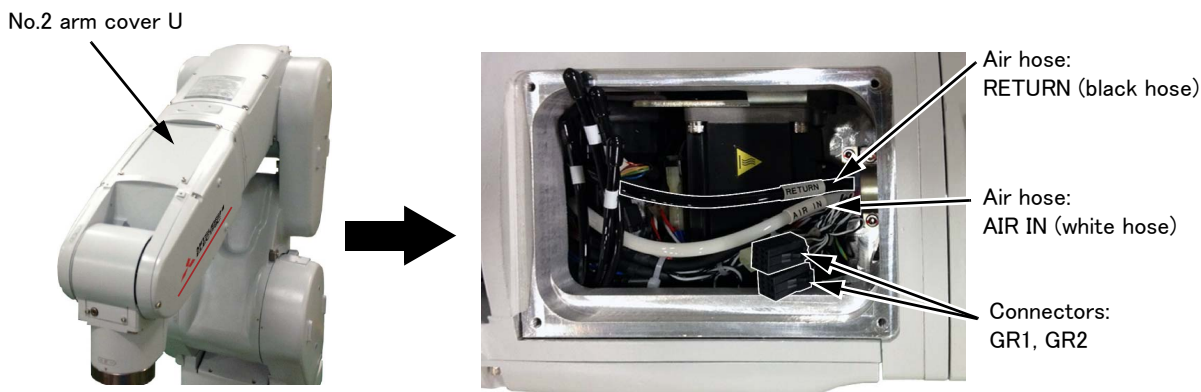

- 4) Connects the air hoses and the connectors. (standard/internal wiring and piping specification common)
- a) Connects the hand output cable inside the forearm (GR1 and GR2) to the connectors of the solenoid-valve set. Connect with the same names.
 Note) In the solenoid-valve set of one set or two sets, connects only connector GR1.
- b) The two air hoses equipped inside the forearm, connects AIR IN (white) to "P" port coupling of the solenoid-valve set, and connects RETURN (black) to "R" port coupling of the solenoid-valve set. The AIR IN (white) air hose is connected with the AIR IN coupling of the robot arm base rear, and the RETURN (black) air hose is connected with the RETURN coupling.

CAUTION

Because the long length air hoses are equipped, please cut and connect it to the suitable length. If that is not right, the air hose breaks within the arm and it becomes the cause that the solenoid valve operation is abnormal.

CAUTION

When connecting the RETURN air hose, be sure to remove the dust cap attached at the RETURN coupling on the robot base section. If the cap is not removed, exhaust air pressure will increase and the solenoid valve may not operate properly. By connecting the exhaust air hose ($\phi 6$: customer preparation) to this RETURN air coupling, exhaust air from the solenoid valve is able to escape to the designated point.

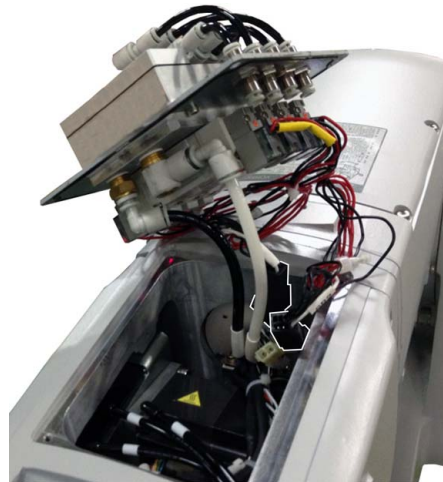
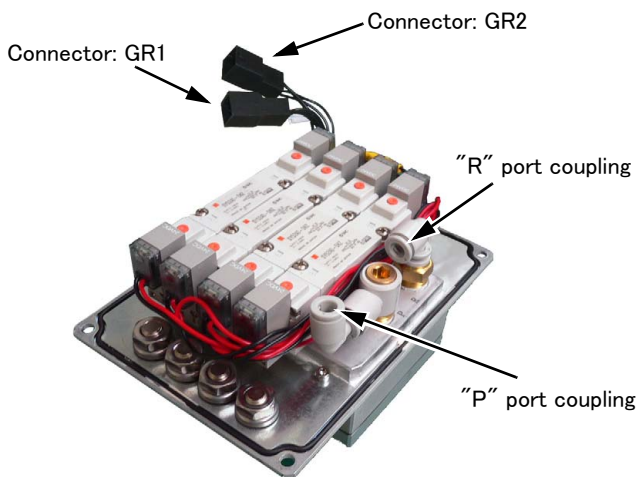

c) Connect the piping inside the wrist. (only internal wiring and piping specification)

Cuts the air hose inside of the wrist to suitable length, and connect to the coupling on the back side of solenoid valve set. The number indicated on the air hoses inside of the wrist is same as the air hoses pulled out of the mechanical interface, so make it the reference at the piping to the tool. [Table 3-14](#) shows the relation between hand condition and port number.

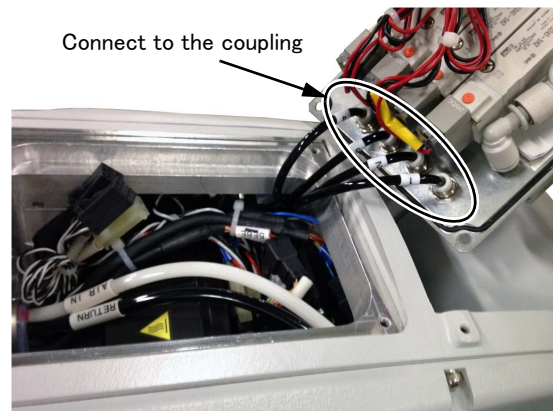
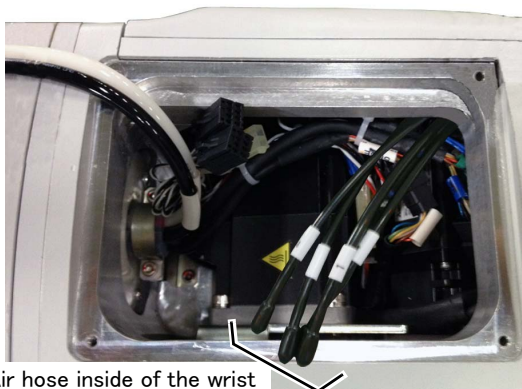

- 5) Installs the solenoid valve set on the forearm upside. (standard/internal wiring and piping specification common)
 Installs the solenoid valve set instead of the No.2 arm cover U removed above.

CAUTION

When you install the solenoid valve set, be careful to not put the cable and air hose between the cover and arm and do not break the air hose. If the cable is inserted, it will become the cause that the cable be broken. And, if the air hose is put or it breaks, it becomes the cause that the solenoid valve operation is abnormal.

Confirms having inserted neither the cable nor the air hose and that the air hose has not broken, and fix the No.2 arm cover U securely by the original fixing screws (Tightening torque: 1.39–1.89N · m). Confirms that the air hose has not broken by removing the No.2 arm cover L.

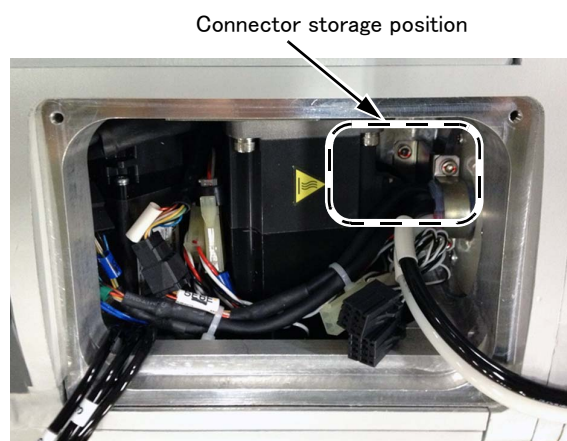
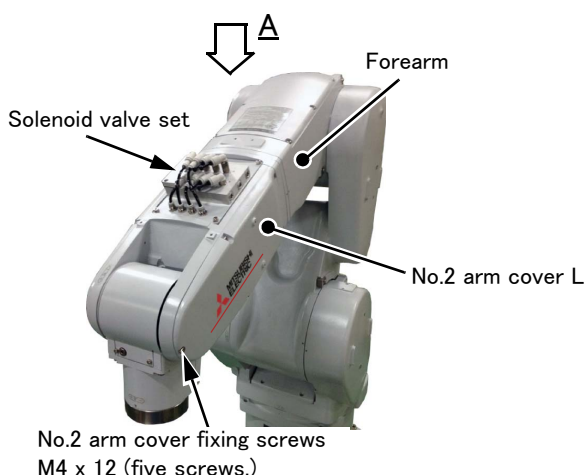

View A

- 6) Connect the tool prepared by the customer with solenoid valve port A and B. (standard/internal wiring and piping specification common)

Install plugs to the port A/B couplings that are not used for the solenoid valve set. Please prepare the air hoses and plugs to use by customer.

Table 3-14 shows the relation between hand condition and port number.

Table 3-14 : Solenoid valve ports and hand number

Hand	Hand condition	Port number	The solenoid valve set in use
Hand 1	OPEN	1	One set
	CLOSE	2	
Hand 2	OPEN	3	Two sets
	CLOSE	4	
Hand 3	OPEN	5	Three sets
	CLOSE	6	
Hand 4	OPEN	7	Four sets
	CLOSE	8	

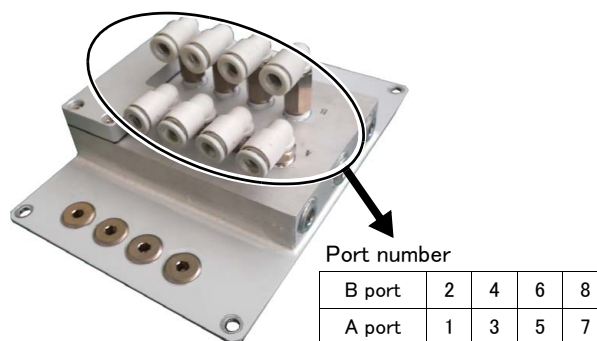

The installing of the solenoid valve set is completed.

3.4 Installing the hand input cable

(1) RV-4FR/7FR/13FR series

The installation procedure of the hand input cable is shown below. Turn the controller's power OFF before this installing operation.

Note) Although the robot's figure described to each page is RV-4FR series, the method is the same on other robot series.

- 1) Loosen the fixing screws (three M4x16 screws) of cable clamp box (under forearm) and remove the cover. For the 6-axis type robot, move the J4 axis in advance to the upside down position by jog operation to facilitate installation of the cable.

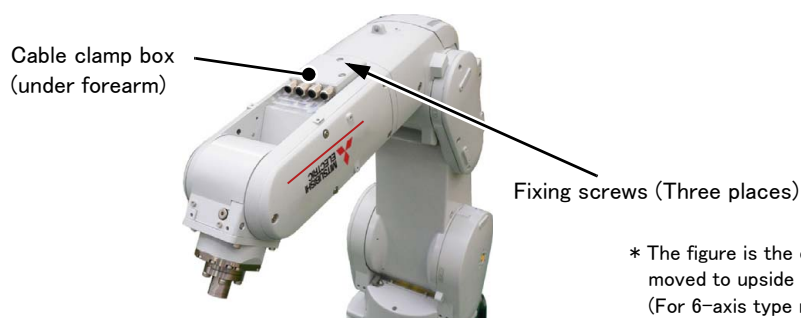

- 2) Feed and fix the optional hand input cable through the inside of cable clamp mounted on the cable clamp box. Uses either one in the cable clamp of both ends.

- a) Loosens the threaded cap of the cable clamp and removes the plug. Use either one place of both ends.
- b) Pass the customer wiring side of cable from inner side. Pass the cable with little by little, and fix the cable securely by tightening the threaded cap as shown in the following figure.

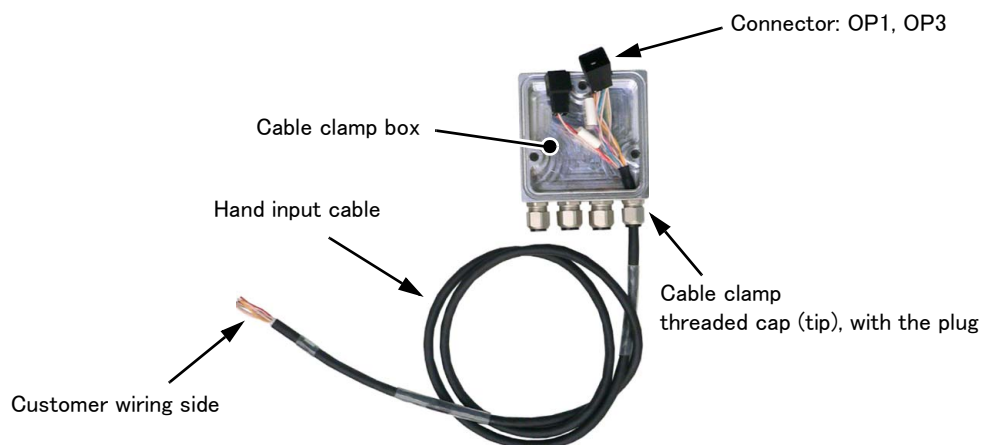

- 3) Connects the connector inside the forearm (OP1 and OP3) to the connector of the hand input cable. Connect with the same names.

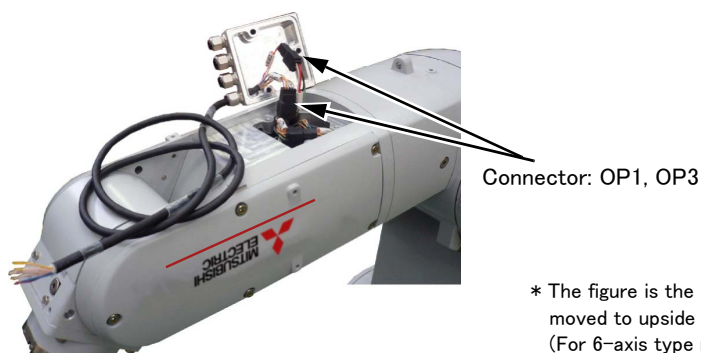

4) Fixes the cable clamp box securely by the fixing screws as before. Installs carefully so that the cable may not be inserted.

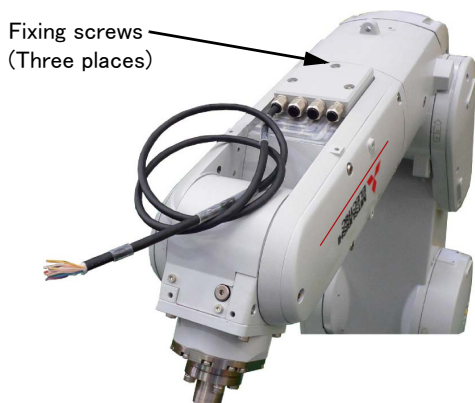

CAUTION When you install the cable clamp box, be careful to not put the cable between the cable clamp box and arm. If the cable is inserted, it will become the cause that the cable be broken.

CAUTION When this cable is connected to the robot the power supply is applied to the end of this cable. The end of the cable is free at factory shipping. so, if the tool side is not connected it may be cause of the trouble such as broken the fuse by short circuit. Before connecting to the robot, customer should check whether or not the cable tip has been properly treated.

* The figure is the example to which the J4 axis was moved to upside down position by jog operation. (For 6-axis type robot)

The installing of the cable clamp box is completed. Pin assign of the hand input cable is shown in [Table 3-15](#).

Table 3-15 : Pin assign of hand input cable

Color	Connector ^{Note1)}	Pin number: names	Color	Connector ^{Note1)}	Pin number: names
Purple	OP1	A1: HC1	Yellow	OP3	A1: +24V(HND)
Brown		A2: HC2	Green		A2: +24G(HND)
Blue		A3: HC3	-		Reserved
Black		A4: HC4	-		Reserved
Red		B1: HC5			
White		B2: HC6			
Gray		B3: HC7			
Pink		B4: HC8			

Note1)The connector shows the connector name connected to the robot-arm side.

3.5 Installing the hand output cable

(1) RV-4FR/7FR/13FR series

As shown in Fig. 3-7, connects with connector GR1 and GR2 inside the forearm, and pulls out the hand output cable from the cable clamp box at the forearm lower part.

Note) • When installing the hand output cable for the safety, turn OFF the power supply of the controller.
The cable clamp box in Fig. 3-7 shows the example of four-clamps type.

- Although the robot's figure described to each page is RV-4FR series, the method is the same on other robot series.

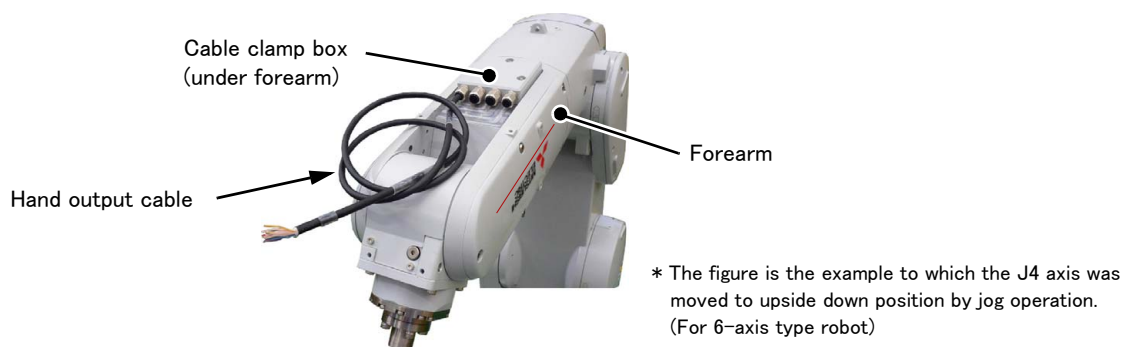
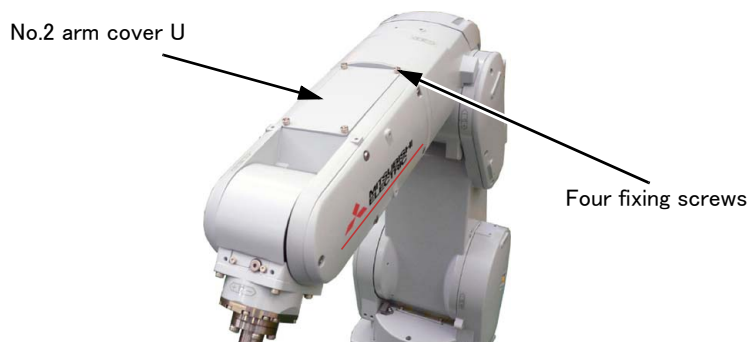

Fig.3-7 : Image which pulled out hand output cable

The installation procedure of the hand output cable is shown below. Turn the controller's power OFF before this installing operation.

- 1) Loosen the fixing screws (four M4x12 screws) of No.2 arm cover U and remove the cover.



- 2) Loosen the fixing screws (three M4x16 screws) of cable clamp box (under forearm) and remove it.
For the 6-axis type robot, move the J4 axis in advance to the upside down position by jog operation to facilitate installation of the cable.

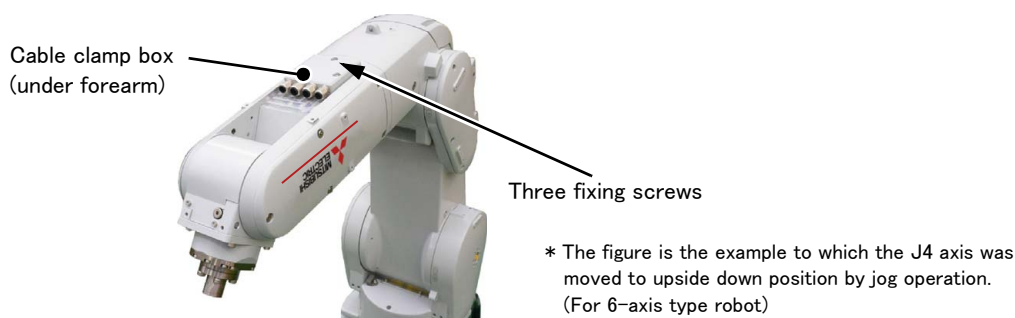

- 3) Feed the hand output cable through to the cable clamp box side from No.2 arm cover U side inside the arm. When the cable inside the No.2 arm cover U is pulled out, it will become easy. Feed the hand output cable through between the motors. (ellipse position of following figure)



- 4) Connects the connector inside the forearm (GR1 and GR2) to the connector of the hand output cable. Connect with the same names.



- 5) Feed the hand output cable through the cable clamp box. Loosens the threaded cap of the cable clamp and removes the plug of the cable clamp box. (Tip) Pass the cable with little by little, and pulls out the needed length, and fix the cable securely by tightening the threaded cap.

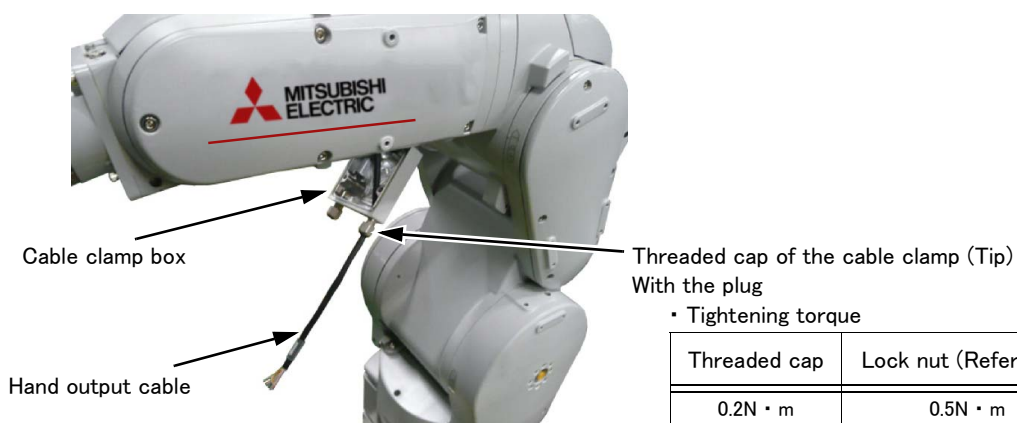

6) Fixes the cable clamp box securely by the fixing screws as before. Installs carefully so that the cable may not be inserted.

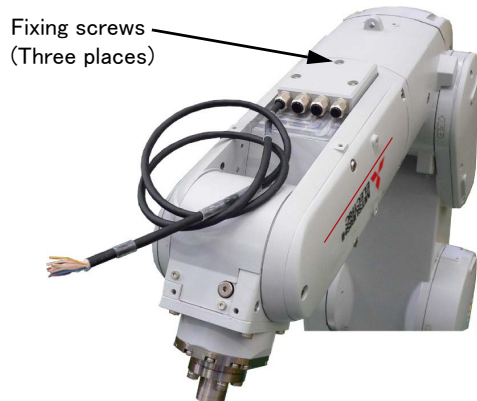

* The figure is the example to which the J4 axis was moved to upside down position by jog operation.
(For 6-axis type robot)

⚠ CAUTION

When you install the cable clamp box, be careful to not put the cable between the cable clamp box and arm. If the cable is inserted, it will become the cause that the cable be broken.

7) Fixes the No.2 arm cover U securely by the fixing screws as before. Installs carefully so that the cable may not be inserted.

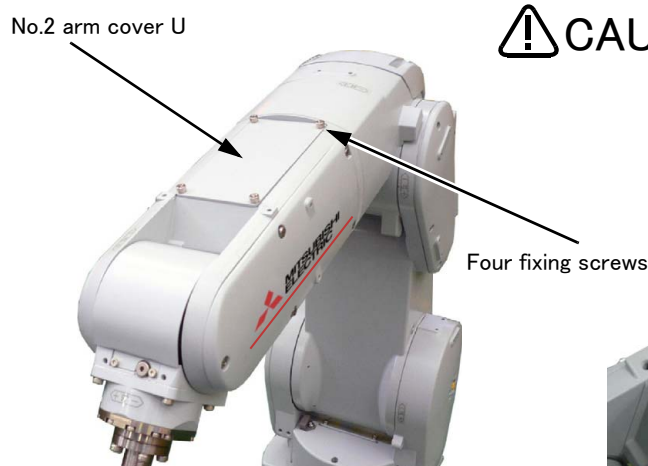

⚠ CAUTION

When you install the No.2 arm cover U, be careful to not put the cable between the cable clamp box and arm. If the cable is inserted, it will become the cause that the cable be broken.



The condition of storing the cable inside the No.2 arm cover U

The installing of the cable clamp box is completed. Pin assign of the hand output cable is shown in [Table 3-16](#) and [Table 3-17](#).

Table 3-16 : Pin assign of hand output cable (sink type)

Color	Connector	Pin number: names	Color	Connector	Pin number: names
Yellow	GR1	A1: +24V	Green	GR2	A1: +24V
-		A2: Reserved	-		A2: Reserved
Purple		A3: GR1 (Hand output 1)	Red		A3: GR5 (Hand output 5)
Brown		A4: GR2 (Hand output 2)	White		A4: GR6 (Hand output 6)
Blue		B1: GR3 (Hand output 3)	Gray		B1: GR7 (Hand output 7)
Black		B2: GR4 (Hand output 4)	Pink		B2: GR8 (Hand output 8)
-		B3: Reserved	-		B3: Reserved
-		B4: Reserved	-		B4: Reserved

Table 3-17 : Pin assign of hand output cable (source type)

Color	Connector	Pin number: names	Color	Connector	Pin number: names
Yellow	GR1	A1: 24G	Green	GR2	A1: 24G
-		A2: Reserved	-		A2: Reserved
Purple		A3: GR1 (Hand output 1)	Red		A3: GR5 (Hand output 5)
Brown		A4: GR2 (Hand output 2)	White		A4: GR6 (Hand output 6)
Blue		B1: GR3 (Hand output 3)	Gray		B1: GR7 (Hand output 7)
Black		B2: GR4 (Hand output 4)	Pink		B2: GR8 (Hand output 8)
-		B3: Reserved	-		B3: Reserved
-		B4: Reserved	-		B4: Reserved

3.6 Installing the forearm external wiring set/base external wiring set

The installation procedure of forearm external wiring set/base external wiring set is shown below.

When the forearm external wiring set and base external wiring set are used in the recommended pairs (see [Table 3-18](#)), the cables for the same purpose can be pulled out from the forearm section and base section.

Table 3-18 : Internal wiring and piping specification types

Pairing (recomm endation)	Option type	Cable length (mm) <i>Note1)</i>	Wiring (cable for the connection to each equipment)			
			Hand input signal <i>Note2)</i>	Vision sensor camera	Force sensor unit	Multifunctional electric hand
1	1F-HB01S-01 (Forearm)	1,000	Eight points	1	Either one unit	
	1F-HA01S-01 (Base)	500	–	1	Either one unit	
2	1F-HB02S-01 (Forearm)	1,000	–	1	1	1
	1F-HA02S-01 (Base)	500	–	1	1	1

*Note1)*The length from the cable clamp box to the connector.

*Note2)*Although the connector is attached to the customer wiring side of hand input cable, the connector can be cut, and connect to the tool of the customer preparation. The color and signal name of the wire are shown in [Table 3-20](#).

Turn the controller's power OFF before this installing operation. Refer to [Page 103](#), "5.3.2 Installing/removing the cover" for removing/ installing the cover.

Note) Although the robot's figure described to each page is RV-4FR series, the method is the same on other robot series.

3.6.1 Installing the forearm external wiring set

Use this option set to replace the existing cable clamp box.

The installation summary is shown in Fig. 3-8.

For the 6-axis type robot, move the J4 axis in advance to the upside down position by jog operation to facilitate installation of this option.

- 1) Loosen the fixing screws (three M4x16 screws) of cable clamp box (under forearm) and remove the box.
- 2) Connects the connector of robot arm side inside the forearm to the connector of Forearm external wiring set. Connect with the same names, and keep it into the forearm. The connector to connect is shown in Table 3-19.

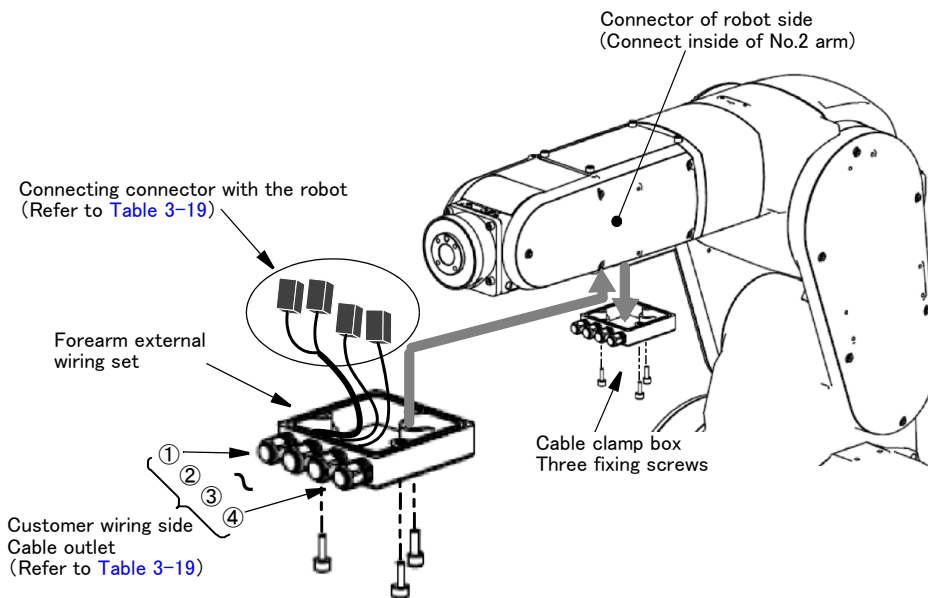

Fig.3-8 : Installing the Forearm external wiring set

Table 3-19 : Cable to pull out and robot side connection connector

Forearm external wiring set	Cable to pull out			Robot side connection connector
	Outlet	Name	Purpose of use	
1F-HB01S-01	①	HC	Hand input cable ^{Note1)}	OP1, OP3
	②	LAN	Vision sensor controller	LAN
	③	Reserved		
	④	E · F1	Force sensor	OP4, OP2
1F-HB02S-01	①	Reserved		
	②	LAN	Vision sensor controller	LAN
	③	E · F1	Reserved	OP1, OP3
	④	E · F2	Force sensor	OP4, OP2

Note1) Although the connector is attached to the customer wiring side of the hand input cable, it can use by cutting. Pin assign of the hand input cable is shown in Table 3-20.

- 3) Install Forearm external wiring set on the position where cable clamp box was being installed, by using original three fixing screws. Installs carefully so that the cable etc may not be inserted.
- 4) Connects the cable pulled out to the tool or sensor etc which customer will use. The Outlet and cable names of each cables are shown in Table 3-19. You can fix the cable by using the screw holes on the robot arm. (refer to separate "Standard Specifications Manual")

Note) Although the connector is attached to the customer wiring side of the hand input cable, it can use by cutting. Pin assign of the hand input cable is shown in Table 3-20.

Table 3-20 : Pin assign of hand input cable

Color	Signal name	Connector (HC) ^{Note1)}	Color	Signal name	Connector (HC) ^{Note1)}
Purple	HC1	A1	Red	HC5	B1
Brown	HC2	A2	White	HC6	B2
Blue	HC3	A3	Gray	HC7	B3
Black	HC4	A4	Pink	HC8	B4
Yellow	+24V(HND)	A6	Green	RG(HND)	B6

Note1) Shows the pin number of the connector previously attached to the customer wiring side.

Connector type: 1-1827864-6, Pin type: 1827570-2, Maker: Tyco Electronics

- 5) Confirms after the connection that the cable interferes with neither the robot arm nor the peripheral device and the not having receive stress. And, confirms that the tool, the sensor, etc. operate correctly.

The installing of the forearm external wiring set is completed.

3.6.2 Installing the base external wiring set

The installation summary of the base external wiring set is shown below. Mounts this option instead of the CONBOX cover R.

Note) Although the robot's figure described to each page is RV-4FR series, the method is the same on other robot series.

- 1) Loosen the fixing screws (three M4x16 screws) of CONBOX cover R and remove the box.
- 2) The connector: LAN, CNOP1 is in CONBOX cover R. The connector is previously attached to the connector CNOP1. Removes this connector.
- 3) Connects the connector of base external wiring set to the connector of robot arm side. Connect with the same name.

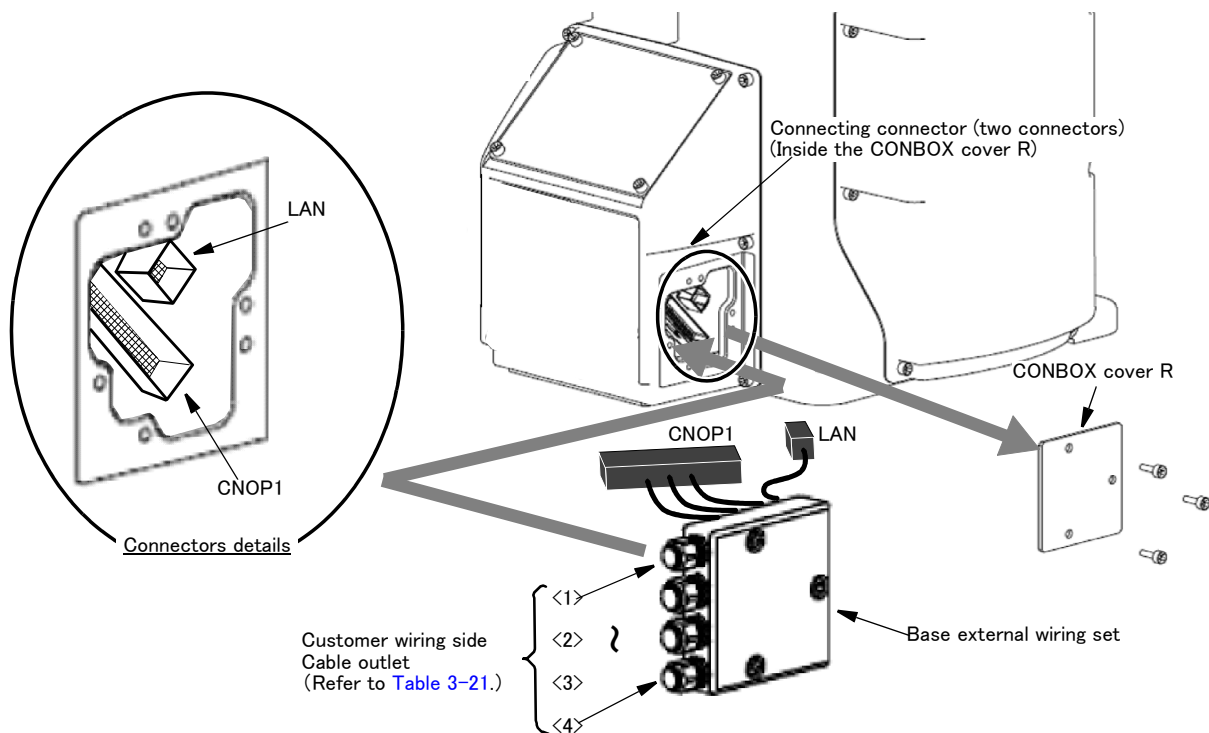

Fig.3-9 : Installing the base external wiring set (1F-HA01S-01, 1F-HA02S-01)

- 4) Install base external wiring set on the position where CONBOX cover R was being installed, by using original three fixing screws. Installs carefully so that the cable etc may not be inserted.
- 5) Connects the cable of base external wiring set to the multifunctional electric hand, force sensor interface etc which customer will use. The outlet and cable names of each cables are shown in Table 3-21.

Table 3-21 : Cable to pull out and outlet

Base external wiring set	Cable to pull out			Robot side connection connector	Grounding process	Installation of ferrite core
	Outlet	Name	Purpose of use			
1F-HA01S-01	<1>	E · F1	Multifunctional electric hand	CNOP1	Not require	Require
			Force sensor interface		Require	Not require
	<2>	Reserved				
	<3>	LAN	Vision sensor controller	LAN	Not require	Not require
<4>	RIO	Multifunctional electric hand controller	CNOP1	Not require	Require	
1F-HA02S-01	<1>	E · F2	Force sensor interface	CNOP1	Require	Not require
	<2>	E · F1	Multifunctional electric hand controller	CNOP1	Not require	Require
	<3>	LAN	Vision sensor controller	LAN	Not require	Not require
	<4>	RIO	Multifunctional electric hand controller	CNOP1	Not require	Require

6) Grounding and installation of a ferrite core

The cable which connects the multifunctional electric hand controller or force sensor interface needs installing a ferrite core or grounding according to [Table 3-21](#). Failure to perform the grounding or install a ferrite core causes malfunction. Perform the grounding and install a ferrite core for the internal wiring and piping specification robot as well.

The method is shown below.

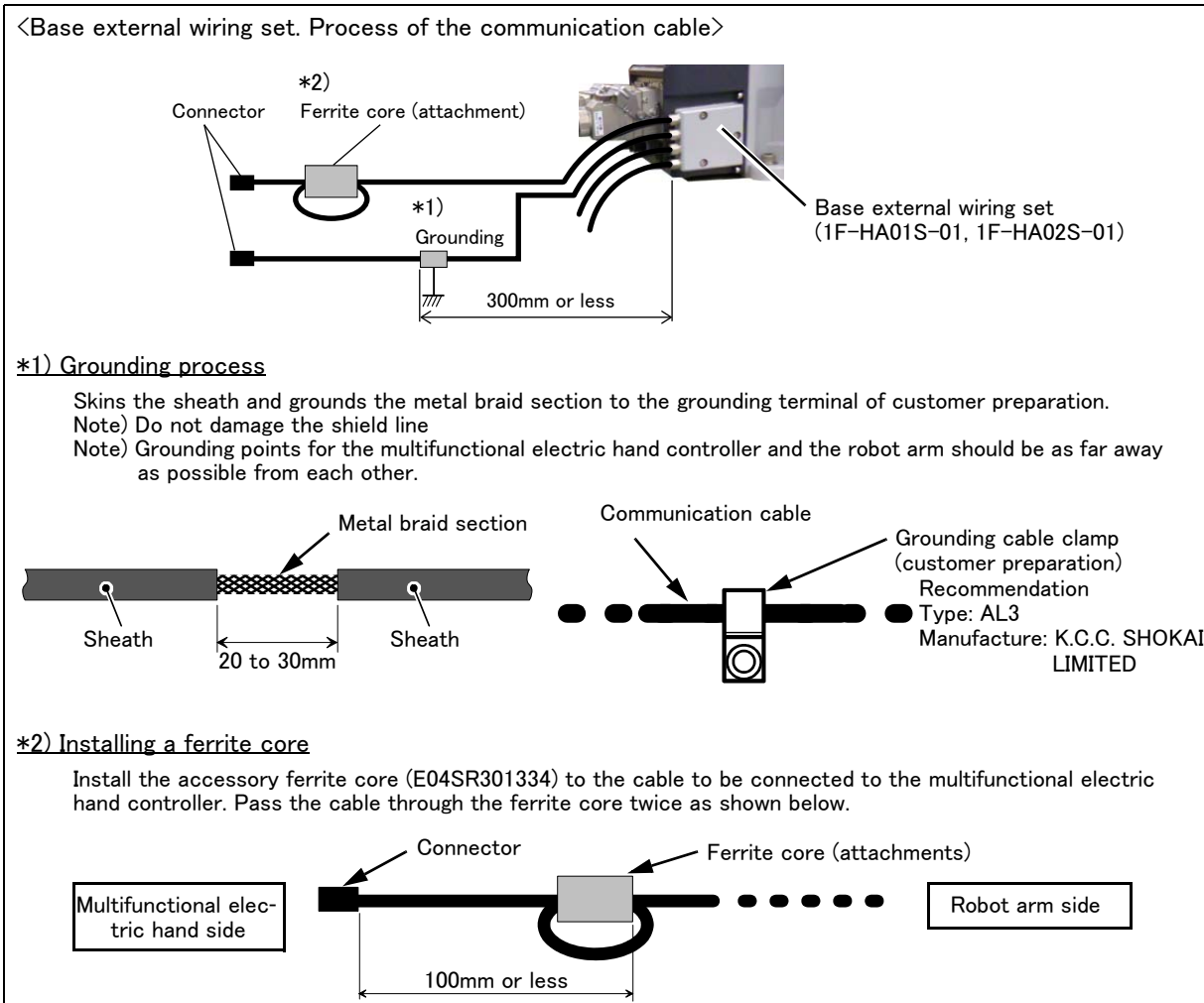

The installing of the base external wiring set is completed.

4 Basic operations

The basic operations from creating the program to automatic operation are explained in section "4. Basic operations" in the "Controller setup, basic operation, and maintenance" manual. Refer that manual as necessary.

5 Maintenance and Inspection

The maintenance and inspection procedures to be carried out to use the robot for a long time without trouble are described in this chapter. The types and replacement methods of consumable parts are also explained.

5.1 Type of inspection and maintenance works

Maintenance and inspection are divided into the inspections carried out daily, and the periodic inspections carry out at set intervals. Always carry these out to prevent unforeseen trouble, to maintain the product for a long time, and to secure safety.

Table 5-1 lists the type of inspection and maintenance works.

Table 5-1 : Type of inspection and maintenance works

No.	Type of inspection and maintenance works		Description	Operating time ^{Note1)}
1	Daily inspection		Inspection works to be performed every day before starting operation for the safe use of the robot.	–
2	Periodic inspection	Monthly inspection	Inspection and maintenance works to be performed every month.	Every 300hr
3		6-month inspection	Inspection and maintenance works to be performed every 6 months.	Every 1,800hr
4		2-year inspection	Inspection and maintenance works to be performed every 2 years.	Every 7,200hr
5		Battery replacement	Replacement of the backup battery of the robot. Replace the battery every year regardless of the operating hours.	–
6		Lubrication	Lubrication of each axis of the robot. Refer to Page 141 , “5.3.4 Lubrication” for the lubrication schedule.	–

Note1) The operating hours assume the robot operation of 15 hours per day for 20 days per month.

When the robot operates for 8 hours per day, the operating hours per month become about a half of the one under the above condition. Then, the monthly inspection is required every two months. To check the periodic inspection schedule and calculate the operating hours, refer to [Page 98](#), “(2) Schedule”.

5.2 Inspection items

The inspection items for the robot arm are shown below.

Also refer to section "5. Maintenance and inspection" in the "Controller setup, basic operation, and maintenance" manual, and inspect the controller.

5.2.1 Daily inspection items

Table 5-2 shows the procedure and inspection items. If you notice any abnormal condition, take appropriate measures.

Table 5-2 : Daily inspection items (details)

Procedure	Inspection item (details)	Remedies
Before turning power ON (Check the following items before turning the power ON.)		
1	Are any of the robot installation bolts loose? (Visual)	Securely tighten the bolts.
2	Are any of the cover tightening screws loose? (Visual)	Securely tighten the screws.
3	Are any of the hand installation bolts loose? (Visual)	Securely tighten the bolts
4	Is the power supply cable securely connected? (Visual)	Securely connect.
5	Is the machine cable between the robot and controller securely connected? (Visual)	Securely connect.
6	Are there any cracks, foreign contamination or obstacles on the robot and controller cover?	Replace with a new part, or take remedial measures.
7	Is there any abnormality in the pneumatic system? Are there any air leaks, drain clogging or hose damage? Is the air source normal? (Visual)	Drain the drainage, and remedy the air leaks (replace the part).
After turning the power ON (Turn the power ON while monitoring the robot.)		
1	Is there any abnormal motion or abnormal noise when the power is turned ON?	Follow the troubleshooting section.
During operation (try running with an original program)		
1	Check whether the movement points are deviated? Check the following points if there is any deviation. 1. Are any installation bolts loose? 2. Are any hand installation section bolts loose. 3. Are the positions of the jigs other than the robot deviated? 4. If the positional deviation cannot be corrected, refer to "Troubleshooting", check and remedy.	Follow the troubleshooting section.
2	Is there any abnormal motion or abnormal noise? (Visual)	Follow the troubleshooting section.

5.2.2 Periodic inspection

The inspection items and timings for the robot arm are shown below.

(1) Inspection item

Carry out periodic inspection given in [Table 5-3](#).

Table 5-3 : Periodic inspection items (details)

Inspection item (details)	Remedies
Monthly inspection	
Are any of the bolts or screws on the robot arm loose?	Securely tighten the bolts.
Are any of the connector fixing screws or terminal block terminal screws loose?	Securely tighten the screws.
2-year inspection ^{Note1)}	
Is the friction at the timing belt teeth severe?	If the teeth are missing or severe friction is found, replace the timing belt.
Is the timing belt tension value more than the guideline value? Does any position mismatch occur?	When the tension value becomes less than the guideline value, the timing belt must be replaced.
Battery replacement	
Replace the backup battery in the robot arm. Replace the battery every year regardless of the operating hours.	Replace it referring to Page 147 , "5.3.5 Replacing the backup battery".
Lubrication	
Check the lubrication schedule for each axis, and perform lubrication. The lubrication schedule differs according to the model.	Lubricate it referring to Page 141 , "5.3.4 Lubrication".

Note1) When the robot is operated 24 hours a day or with a heavy load, it is recommended to be inspected every 6 months (1,800hr).

(2) Schedule

The following shows the schedule for the periodic inspection works. Perform the periodic inspection works as appropriate according to the following table.

Operating time Note1)	Inspection schedule		Type of periodic inspection works Note2)				
	15 hours per day	8 hours per day	Monthly inspection	6-month inspection	2-year inspection	Battery replacement	Lubrication
300hr	1 month	2 months	○			Every year Note3)	As appropriate Note4)
600hr	2 months	4 months	○				
900hr	3 months	6 months	○				
1,200hr	4 months	8 months	○				
1,500hr	5 months	10 months	○				
1,800hr	6 months	12 months	○	○			
:	:	:	:	:	:		
3,600hr	12 months	24 months	○	○			
:	:	:	:	:	:		
7,200hr	24 months	48 months	○	○	○		
:	:	:	:	:	:		
10,800hr	36 months	72 months	○	○			

Note1) The following shows examples of calculation of the operating hours.

- Operating hours when the robot operates 15 hours per day for 20 days per month for three months:
 $15 \text{ hr/day} \times 20 \text{ days/month} \times 3 \text{ months} = 900\text{hr}$
- Operating hours when the robot operates 8 hours per day for 20 days per month for three months:
 $8 \text{ hr/day} \times 20 \text{ days/month} \times 3 \text{ months} = 480\text{hr} \dots \text{Approx. } 500 \text{ hr}$

Note2) The item marked with the circle (○) is to be performed. According to the guideline of the operating hours, perform the inspection to check the items described in [Table 5-3](#).

Note3) Replace the battery every year regardless of the operating hours.

Note4) Check the lubrication interval described in [Page 141, "5.3.4 Lubrication"](#).

5.3 Maintenance and inspection procedures

The procedures for carrying out the periodic maintenance and inspection are described in this section. Thoroughly read the contents, and follow the instructions. This work can be commissioned to the Mitsubishi Service Department for a fee. (Never disassemble, etc., the parts not described in this manual.)

The maintenance parts, etc., required for the customer to carry out maintenance and inspection are described in Page 152, "5.5 Maintenance parts" of this manual. Always contact your dealer when parts are needed.



CAUTION

The origin of the machine system could deviate when this work is carried out. "Review of the position data" and "re-teaching" will be required.

5.3.1 Robot arm structure

An outline structure drawing is shown below.

(1) RV-2FR series

- 1) The rotation of the J1 axis motor <1> arranged in the base is conveyed to the reduction gears <3> via the timing belt <2> to rotate the J1 axis.
RV-2FR/2FRL: Brakes are not mounted in the J1 axis motor.
RV-2FRB/2FRLB: Non-excitation magnetic brakes are mounted in the J1 axis motor.
- 2) The rotation of the J2 axis motor <4> arranged in the No.1 arm is conveyed to the reduction gears <6> via the timing belt <5> to rotate the J2 axis.
Non-excitation magnetic brakes are mounted in the J2 axis motor.
- 3) The rotation of the J3 axis motor <7> arranged in the No.1 arm is conveyed to the reduction gears <9> via the timing belt <8> to rotate the J3 axis.
Non-excitation magnetic brakes are mounted in the J3 axis motor.
- 4) The rotation of the J4 axis motor <10> arranged in the elbow is conveyed to the reduction gears <12> via the timing belt <11> to rotate the J4 axis.
RV-2FR/2FRL: Brakes are not mounted in the J4 axis motor.
RV-2FRB/2FRLB: Non-excitation magnetic brakes are mounted in the J4 axis motor.
- 5) The rotation of the J5 axis motor <13> arranged in the No.2 arm is conveyed to the reduction gears <16> via the timing belt <14> to rotate the J5 axis. Non-excitation magnetic brakes <17> are mounted via the timing belt <15> in the J5 axis motor.
- 6) The J6 axes differ as follows depending on the type
RV-2FR/2FRL: The rotation of the J6 axis motor <18> arranged in the No.2 arm is conveyed to the reduction gears <21> via the timing belt <19> and gear <20> to rotate the J6 axis. Brakes are not mounted in the J6 axis motor.
RV-2FRB/2FRLB: The rotation of the J6 axis motor <18> arranged in the No.2 arm is conveyed to the reduction gears <21> via the timing belt <19> and gear <20> to rotate the J6 axis. Non-excitation magnetic brakes <23> are mounted via the timing belt <22> in the J6 axis motor.

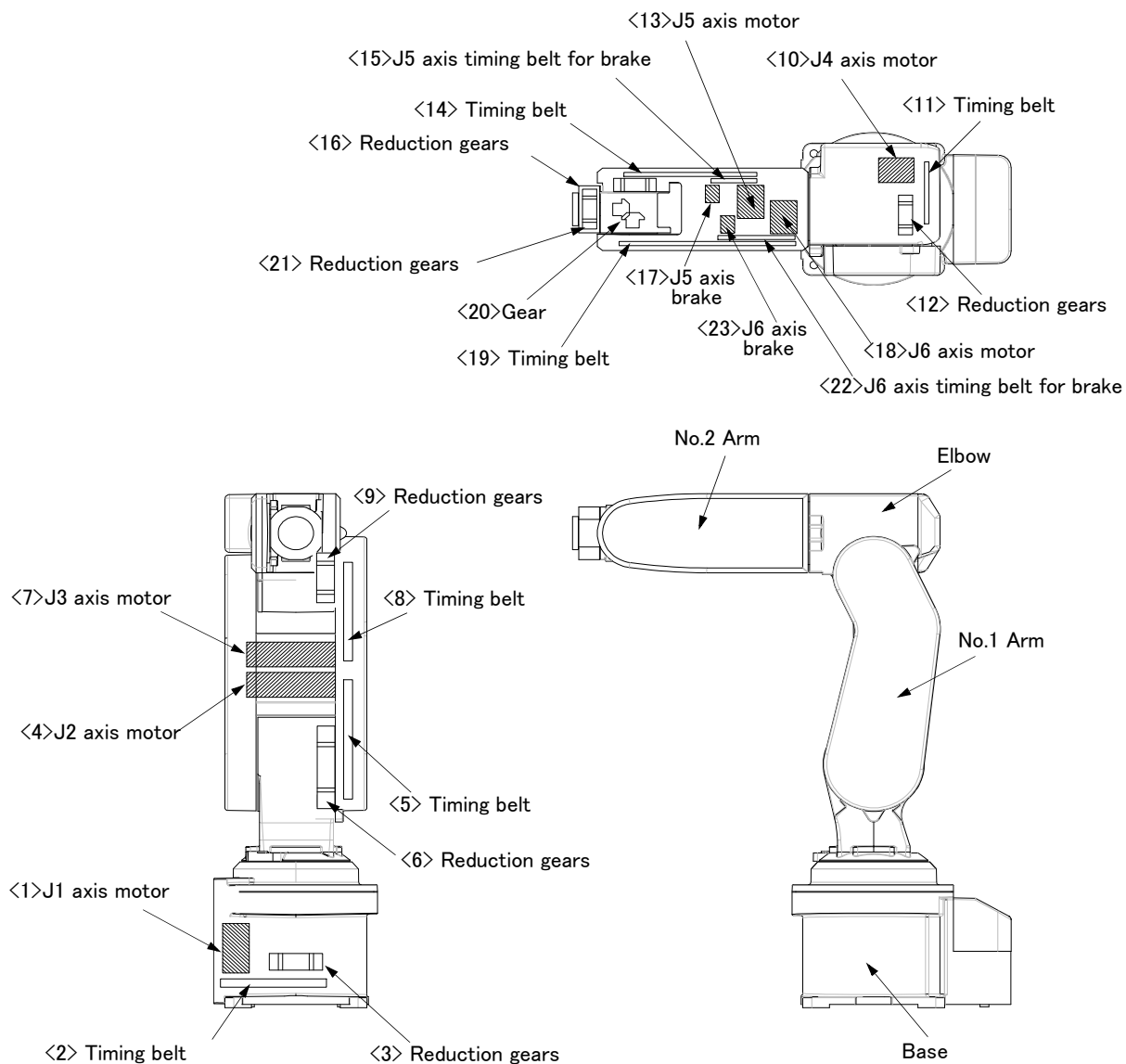

Note) <22> J6 axis brake timing belt and <23> J6 axis brake are only RV-2FRB (all axes have the brake).

Fig.5-1 : Outline structure drawing of robot arm (RV-2FR series)

(2) RV-4FR/7FR series

Non-excitation magnetic brakes are mounted in all axes's motor.

- 1) The rotation of the J1 axis motor <1> arranged in the base is conveyed to the reduction gears <3> via the timing belt <2> to rotate the J1 axis.
- 2) The J2 axis rotation is driven by the J2 axis motor <4> and reduction gears <5>.
- 3) The rotation of the J3 axis motor <7> arranged in the No.1 arm is conveyed to the reduction gears <9> via the timing belt <8> to rotate the J3 axis.
- 4) The rotation of the J4 axis motor <10> arranged in the elbow is conveyed to the reduction gears <12> via the timing belt <11> to rotate the J4 axis.
- 5) The rotation of the J5 axis motor <13> arranged in the No.2 arm is conveyed to the reduction gears <16> via the timing belt <14> to rotate the J5 axis.
- 6) The rotation of the J6 axis motor <18> arranged in the No.2 arm is conveyed to the reduction gears <21> via the timing belt <19> and gear <20> to rotate the J6 axis.

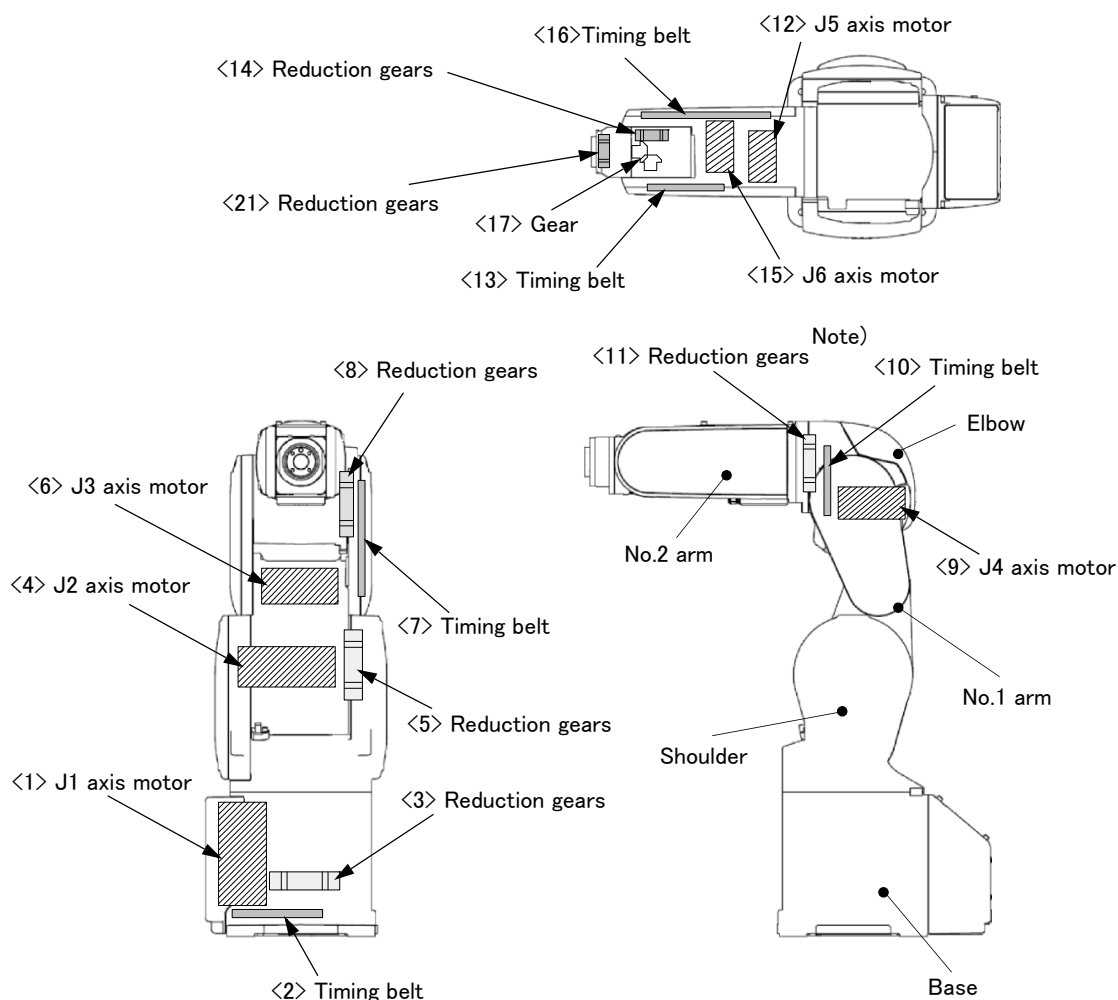

Fig 5-2 : Outline structure of robot arm (RV-4FR/7FR series)

(3) RV-13FR series

Non-excitation magnetic brakes are mounted in all axes's motor.

- 1) The J1 axis rotation is driven by the J1 axis motor <1> and reduction gears <2>.
- 2) The J2 axis rotation is driven by the J2 axis motor <3> and reduction gears <4>.
- 3) The J3 axis rotation is driven by the J3 axis motor <5> and reduction gears <6>.
- 4) The rotation of the J4 axis motor <7> arranged in the elbow is conveyed to the reduction gears <9> via the timing belt <8> to rotate the J4 axis.
- 5) The rotation of the J5 axis motor <10> arranged in the No.2 arm is conveyed to the reduction gears <12> via the timing belt <11> to rotate the J5 axis.
- 6) The rotation of the J6 axis motor <13> arranged in the No.2 arm is conveyed to the reduction gears <16> via the timing belt <14> and gear <15> to rotate the J6 axis.

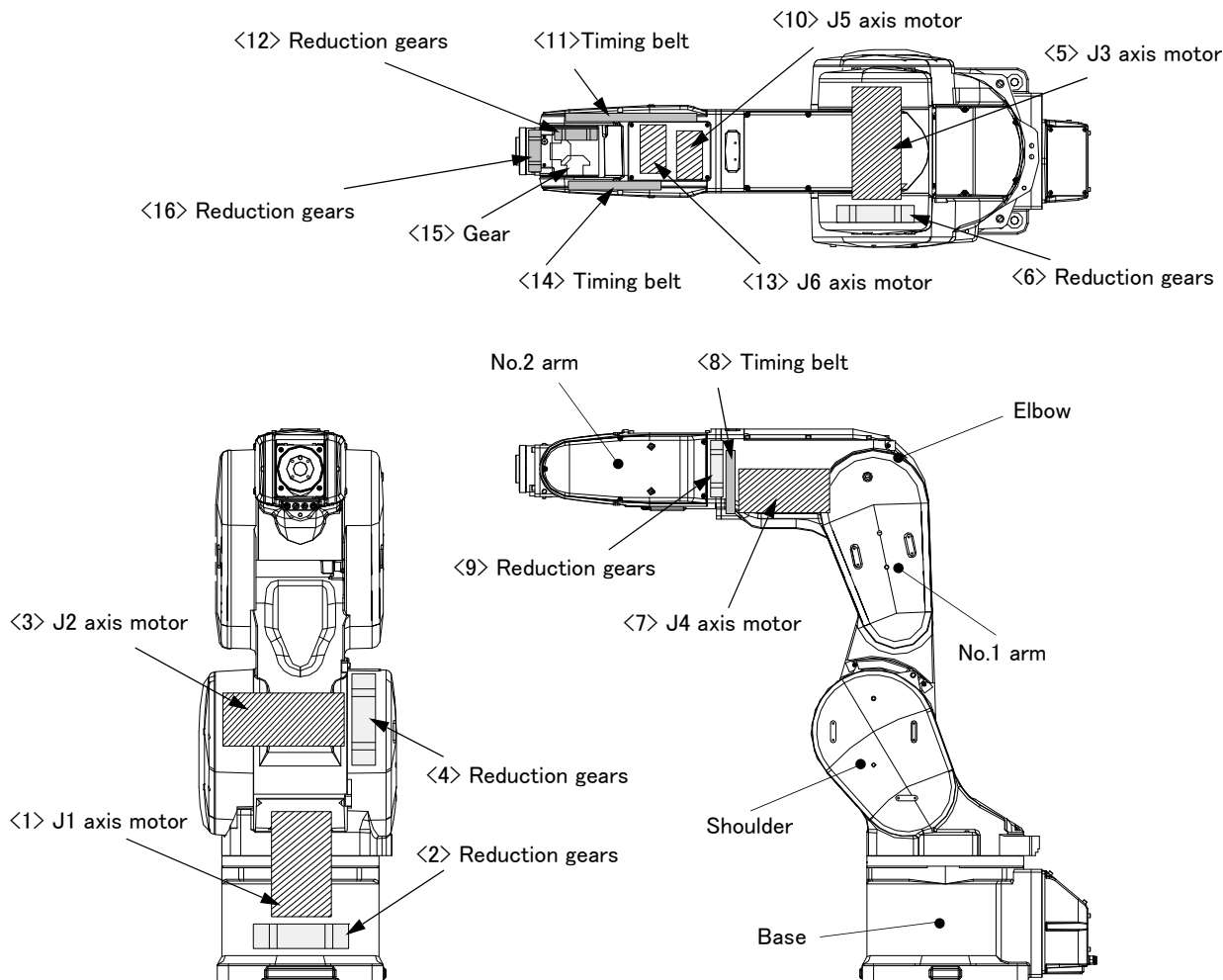

Fig 5-3 : Outline structure of robot arm (RV-13FR series)

5.3.2 Installing/removing the cover

(1) RV-2FR series

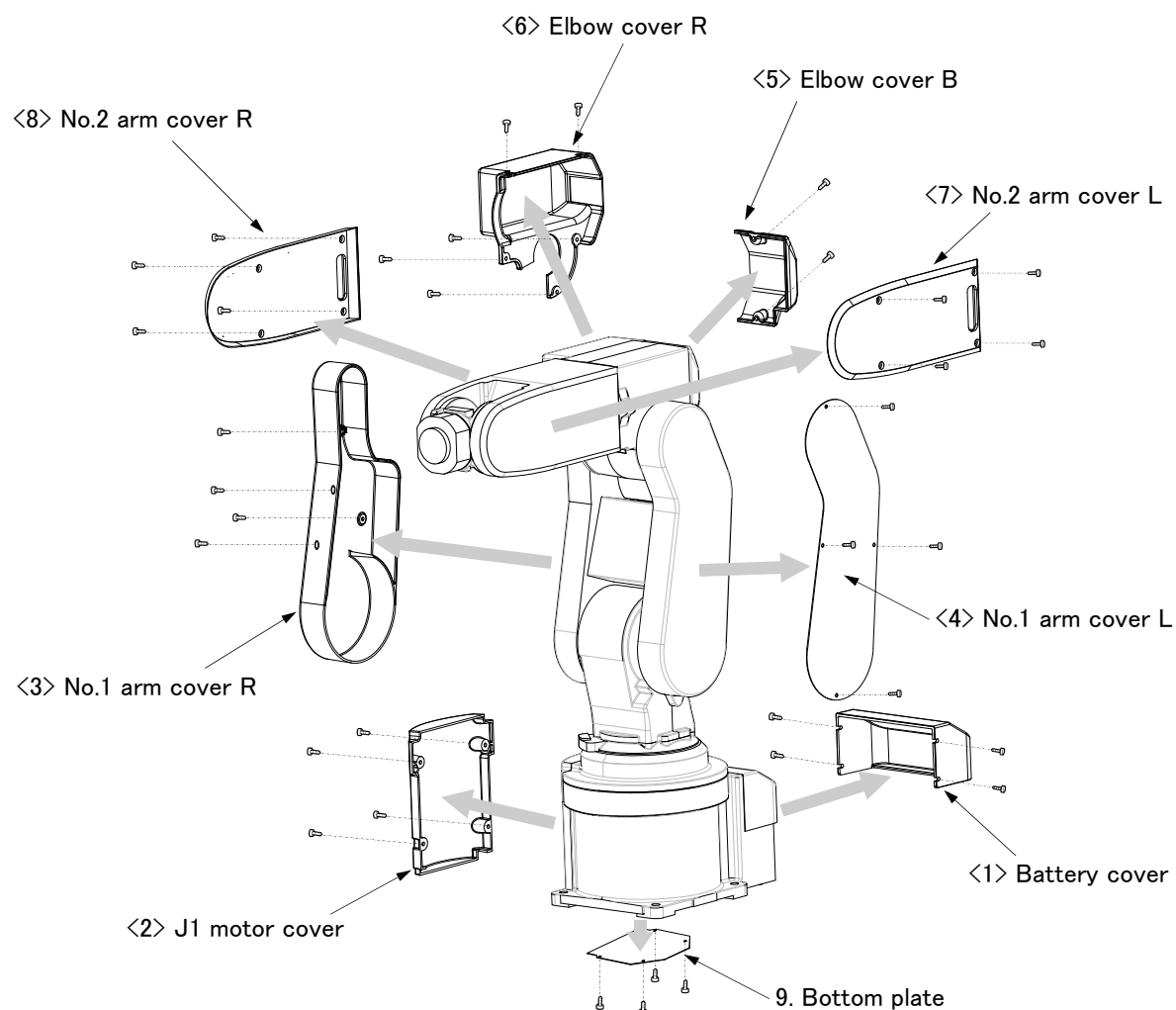

Fig.5-4 : Installing/removing the cover (RV-2FR series)

Table 5-4 : Cover names and installation screw list (RV-2FR series)

No	Cover names	Installation screw ^{Note1)}	Qty	Remarks
<1>	Battery cover	Bind screw M3	4	
<2>	J1 motor cover	Bind screw M3	4	
<3>	No. 1 arm cover R	Bind screw M3	4	
<4>	No. 1 arm cover L	Low head safety socket M3	4	Nickel-plated screw.
<5>	Elbow cover B	Bind screw M3	2	
<6>	Elbow cover R	Bind screw M3	5	
<7>	No. 2 arm cover L	Bind screw M3	4	
<8>	No. 2 arm cover R	Bind screw M3	4	
<9>	Bottom plate	Low head safety socket M3	4	Nickel-plated screw.

Note1) The tightening torque of each screws are shown below.

M3 screw: 0.608 to 0.824Nm

(1) Refer to Fig. 5-4 and remove the covers.

(2) The names of the cover and installation screw are given in Table 5-4. The number in Table 5-4 correspond to Fig. 5-4.

- (3) Depending on the robot's posture, some covers are hard to be removed. In such a case, change the robot's posture by performing jog operation to remove the covers.
- (4) When reattaching the covers after a maintenance inspection, proceed in the reverse order of their removal. Tightening the screw with the torque shown in [Table 5-4](#).

(2) RV-4FR/7FR series

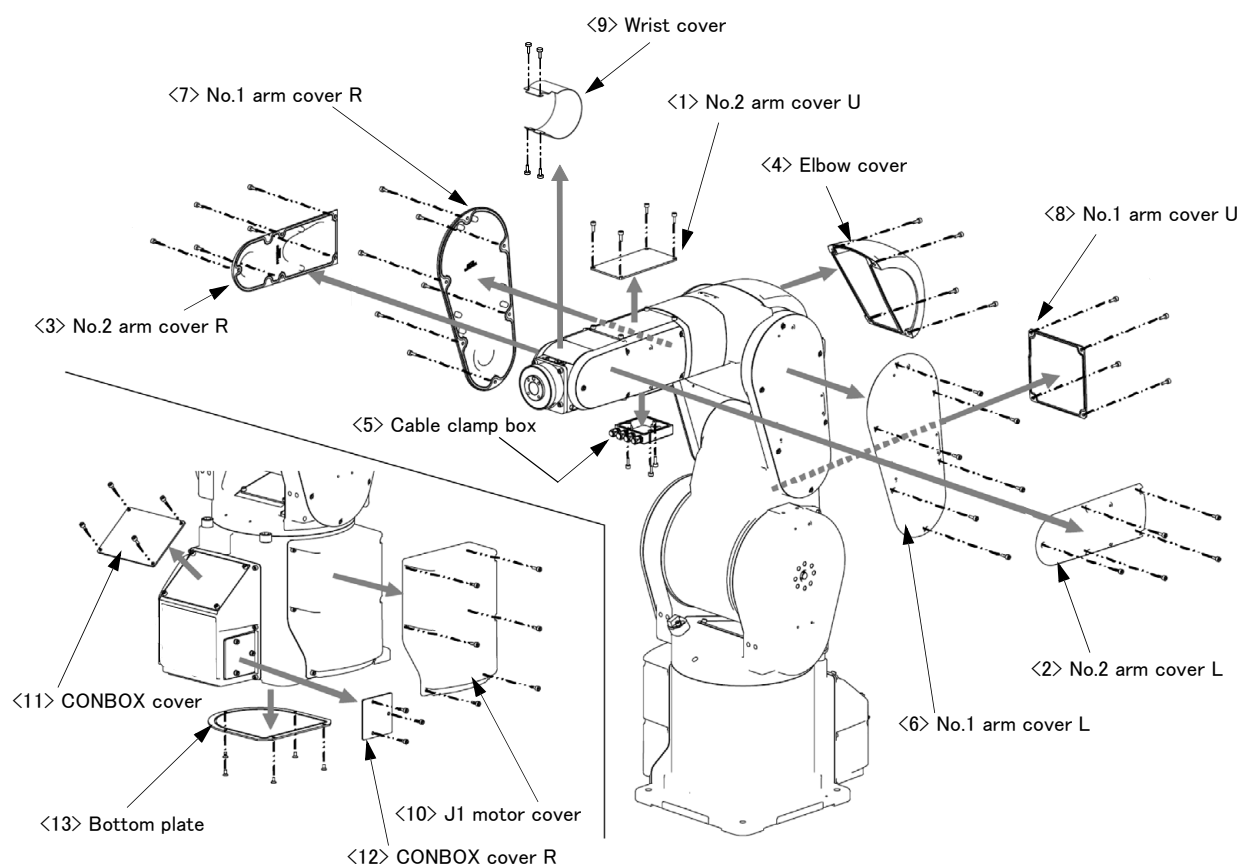

Fig.5-5 : Installing/removing the cover (RV-4FR/7FR series)

Table 5-5 : Cover names and installation screw list (RV-4FR/7FR series)

No.	Cover names	Installation screws ^{Note1)}	Qty	Remarks
<1>	No.2 arm cover U	Hexagon socket head cap screw, M4 x 12	4	
<2>	No.2 arm cover L	Hexagon socket head cap screw, M4 x 12	5	
<3>	No.2 arm cover R	Hexagon socket head cap screw, M4 x 12	5	
<4>	Elbow cover	Hexagon socket head cap screw, M4 x 12	4	For RV-4FR series.
		Hexagon socket head cap screw, M4 x 16	4	For RV-7FR series.
<5>	Cable clamp box	Hexagon socket head cap screw, M4 x 20	3	Only protection specification has seal washer M4
<6>	No.1 arm cover L	Hexagon socket head cap screw, M4 x 12	5	For RV-4FR series.
			6	For RV-7FR series.
<7>	No.1 arm cover R	Hexagon socket head cap screw, M4 x 12	5	For RV-4FR series.
			6	For RV-7FR series.
<8>	No.1 arm cover U	Hexagon socket head cap screw, M4 x 8	4	For RV-4FR/7FR
			6	For RV-4FRL/7FRL
<9>	Wrist cover	Low head cap screw, M3 x 8	4	
<10>	J1 motor cover	Hexagon socket head cap screw, M4 x 12	6	
<11>	CONBOX cover	Hexagon socket head cap screw, M4 x 8	4	
<12>	CONBOX cover R	Hexagon socket head cap screw, M4 x 20	3	Only protection specification has seal washer M4
<13>	Bottom plate	Flat head screw, M4 x 8	5	

Note1) The tightening torque of each screws are shown below.

M3 screw: 0.608 – 0.824 N·m

M4 screw: 1.39 – 1.89 N·m

- (1) Refer to [Fig. 5-5](#), and remove the covers.
- (2) The names of the cover and installation screw are given in [Table 5-5](#). The number in [Table 5-5](#) correspond to [Fig. 5-5](#).
- (3) Depending on the robot's posture, some covers are hard to be removed. In such a case, change the robot's posture by performing jog operation to remove the covers.
- (4) When removing the wrist cover, move the J5 axis to the position of +90 degrees by jog operation.
- (5) When reattaching the covers after a maintenance inspection, proceed in the reverse order of their removal. Tightening the screw with the torque shown in [Table 5-5](#).
- (6) When the cover is removed, the thermal conductive sheet may come off. Reattach the sheet and then attach the cover.
For the position to attach, refer to the figure in "[5.3.3 Inspection replacement of timing belt](#)" on [Page 109](#).

(3) RV-13FR series

RV-13FR series

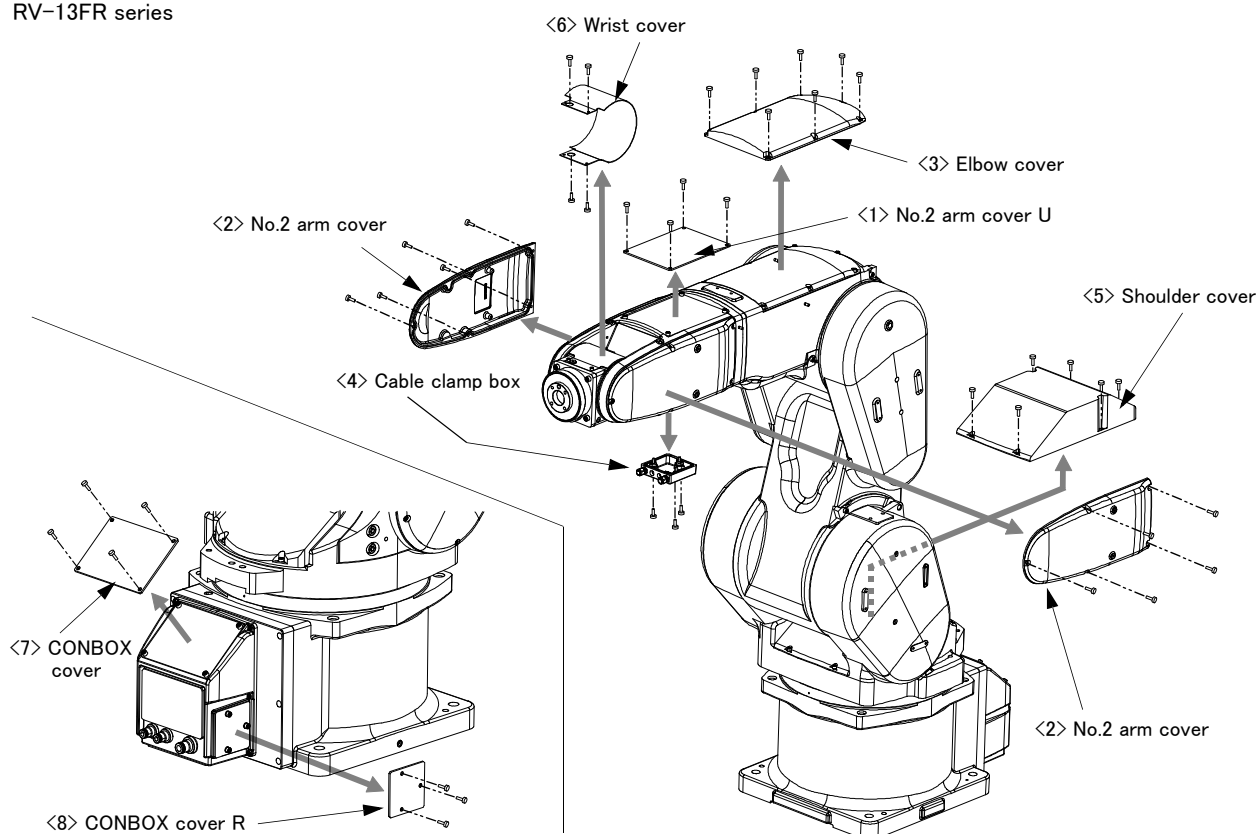

Fig.5-6 : Installing/removing the cover (RV-13FR series)

Table 5-6 : Cover names and installation screw list (RV-13FR series)

No.	Cover names	Installation screws ^{Note1)}	Qty	Remarks
<1>	No.2 arm cover U	Hexagon socket head cap screw, M4 x 12	4	
<2>	No.2 arm cover	Hexagon socket head cap screw, M4 x 12	5/one side	Fix five screws on one side.
<3>	Elbow cover	Hexagon socket head cap screw, M4 x 12	7	
<4>	Cable clamp box	Hexagon socket head cap screw, M4 x 16	3	Only protection specification has seal washer M4
<5>	Shoulder cover	Hexagon socket head cap screw, M4 x 12	6	
<6>	Wrist cover	Low head cap screw, M3 x 8	4	For RV-7FRLL
		Hexagon socket head cap screw, M3 x 8	4	For RV-13FR/13FRL/20FR
<7>	CONBOX cover	Hexagon socket head cap screw, M4 x 8	4	
<8>	CONBOX cover R	Hexagon socket head cap screw, M4 x 20	4	Only protection specification has seal washer M4

Note1) The tightening torque of each screws are shown below.

M3 screw: 0.608 – 0.824 N·m

M4 screw: 1.39 – 1.89 N·m

- (1) Refer to Fig. 5-6, and remove the covers.
- (2) The names of the cover and installation screw are given in Table 5-6. The number in Table 5-6 correspond to Fig. 5-6.
- (3) Depending on the robot's posture, some covers are hard to be removed. In such a case, change the robot's posture by performing jog operation to remove the covers.
- (4) When removing the wrist cover, move the J5 axis to the position of +90 degrees by jog operation.
- (5) When reattaching the covers after a maintenance inspection, proceed in the reverse order of their removal. Tightening the screw with the torque shown in Table 5-6.

- (6) When the cover is removed, the thermal conductive sheet may come off. Reattach the sheet and then attach the cover.

For the position to attach, refer to the figure in "[5.3.3 Inspection replacement of timing belt](#)" on [Page 109](#).

5.3.3 Inspection replacement of timing belt

This robot uses a timing belt for the drive conveyance system. Compared to gears and chains, the timing belt does not require lubrication and has a low noise. However, if the belt usage method and tension adjustment are inadequate, the life could drop and noise could be generated. Sufficient aging to remove the initial elongation of the belt have been carried out before shipment from the factory.

However, depending on the robot working conditions, elongation will occur gradually over a long time. The tension must be confirmed during the periodic inspection.

Please prepare the sound wave type belt tension gauge in inspection of the timing belt. Refer to the [Page 139](#), “(15) Timing belt tension” for the tension of the timing belt.

The recommendation gauge is shown below.

Manufacture: Gates Unitta Asia Company

Type: U-550



Fig.5-7 : Tension adjustment method of timing belt



CAUTION

When the timing belt has to be removed for repair or some other reason, measure the tension before removing the belt.

When the belt is reinstalled, the tension must be the same as the one measured before removal. Otherwise, the life of the belt and the relevant parts may be shortened.

(1) Timing belt replacement period

The timing belt life is greatly affected by the robot working conditions, so a set time cannot be given. However, if the following symptoms occur, replace the belt.

- 1) The belt tension value becomes less than the guideline value.
- 2) A position mismatch or gear teeth skipping occurs.
- 3) The belt is damaged as shown in [Table 5-7](#).

Table 5-7 : Typical damage conditions of the timing belt

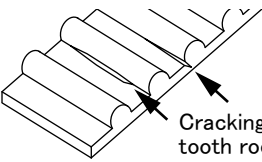
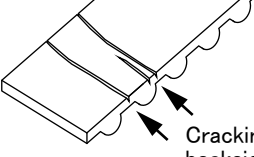
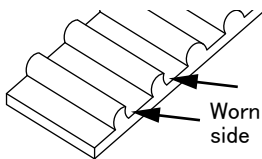
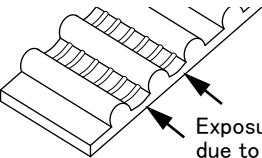
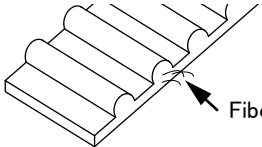
Damage condition	Appearance	Cause
Gear tooth crack	 Cracking at the tooth root	Overload
Backside crack	 Cracking on the backside of the belt	Deterioration of rubber due heat to or ozone
Worn teeth	 Worn out on one side	Overload Excessive or insufficient tension
Tooth bottom abrasion and exposure of cores	 Exposure of cores due to abrasion	Excessive tension
The following is not a belt damage.		
Fibers coming out of the side face of the belt	 Fibers	Manufacturing related factor. This is not a belt damage.

CAUTION Due to the manufacturing of the timing belt, initial wear will occur. Wear chips may accumulate in the cover after approx. 300 hr of operating the robot, but this is not a fault.

CAUTION When the belt is replaced, the machine system origin may deviate. After the replacement, ensure to reset the origin.

(2) Timing belt tension measurement

Rotate the timing pulley A to one direction while visually checking its position, and measure the belt tension at every 90 degrees, four times in total. The average of the four measurements is used as the timing belt tension value.

The timing belt must be pulled tight before the tension is measured. For this purpose, rotate the timing pulley A 90 degrees before measurement. Measure the tension of the belt to be pulled by the movement of the timing pulley A. When the temperature of the robot arm is high, the timing belt tension is increased. To ensure reliability of the measurement, take measurements at least 30 minutes after the robot stops its movement.

Low ambient temperature may make accurate measurements using a tension gauge impossible. In this case, perform the automatic operation or jog operation at measuring target axis for a few minutes, then measure the tension of the belt.

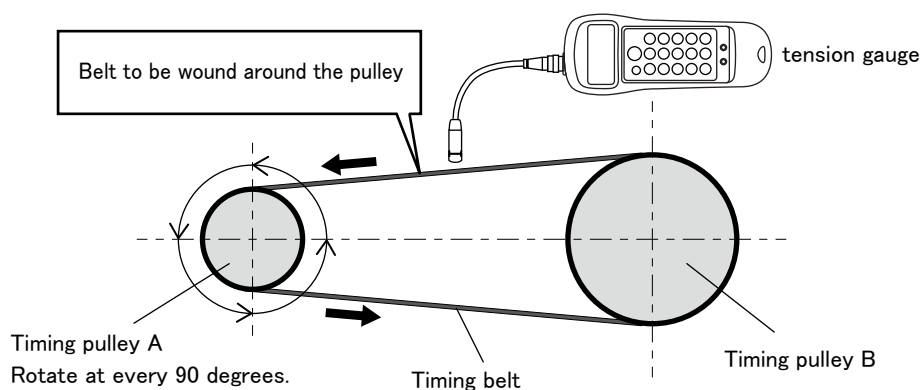

Fig.5-8 : Timing belt tension measurement

The procedure is shown below.

- 1) Turn on the controller's power supply.
- 2) Rotate the timing pulley A to one direction in jog operation while visually checking its position, and measure the belt tension at every 90 degrees, four times in total (for one turn of the timing pulley A).
The amount of movement of each axis when the timing pulley A is rotated 90 degrees are shown in [Page 140, "\(16\) Amount of movement of each axis during the timing belt tension measurement"](#).
- 3) Take an average of the four measurements to determine the timing belt tension value.
During inspection of the timing belt, check that the belt tension exceeds the replacement guideline value in [Page 139, "\(15\) Timing belt tension"](#). When the belt tension value becomes less than the guideline value, the belt must be replaced immediately.

(3) RV-2FR series: Inspection and replacement of J1-axis timing belt

The reference figure at inspection and replacement of the timing belt is shown in Fig. 5-9.

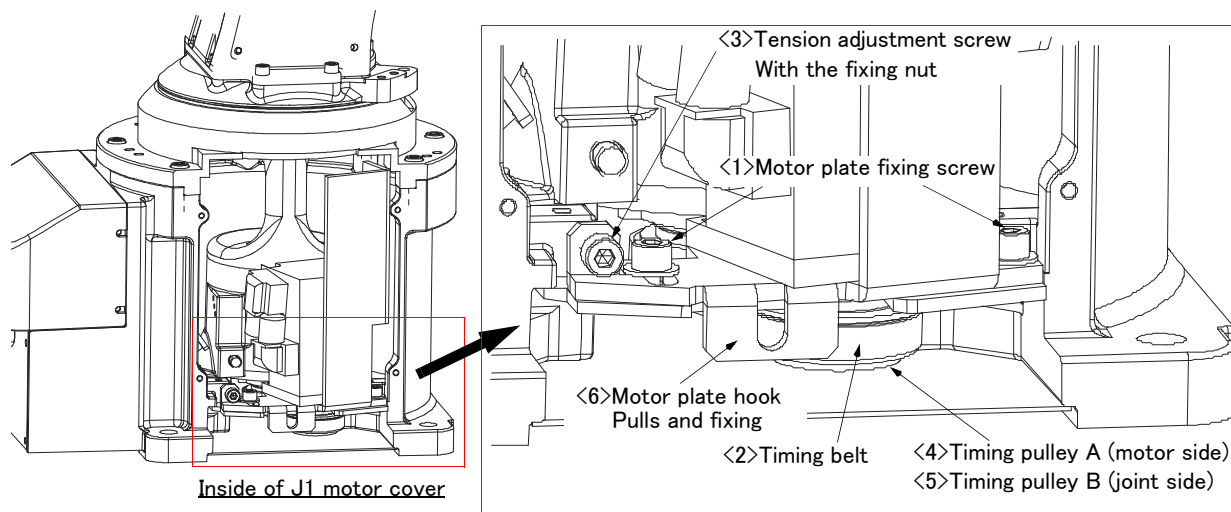

Fig.5-9 : Inspection, maintenance and replacement of J1 axis timing belt (RV-2FR series)

■ Inspecting the J1 axis timing belt

- 1) Refer to Page 103, "5.3.2 Installing/removing the cover", and remove the J1 motor cover.
- 2) Visually confirm that the symptoms indicated in Page 110, "(1) Timing belt replacement period" have not occurred with the timing belt.
- 3) Refer to Page 111, "(2) Timing belt tension measurement", and confirm the belt tension.
- 4) Install the J1 motor cover securely as before and finish inspection.

■ Replacing the J1 axis timing belt

CAUTION

It is possible for the customer to replace the timing belt, but precise adjustment is needed to prevent malfunction of the relevant parts. To ask for replacement of the timing belt, contact the dealer.

Timing belt replacement of the J1 axis removes the bottom plate in the robot-arm bottom, and replace the belt from the robot's bottom. For this reason, it is necessary to remove the robot arm from the installation surface and to place it sideways. Remove the machine cable or piping, etc. corresponding to the usage condition, and put the robot on the floor sideways.

CAUTION

When removing and placing the robot arm, place J1 motor cover upward. Moreover, also to turn the No.1 arm cover upward, turn the J1 axis to the front by jog operation beforehand. (joint angle is near 0 degree) This is the necessity to not damaging the resin cover.

Topple slowly so that a shock may not be given. If you have the resin cover, there is a possibility that the cover may be broken.

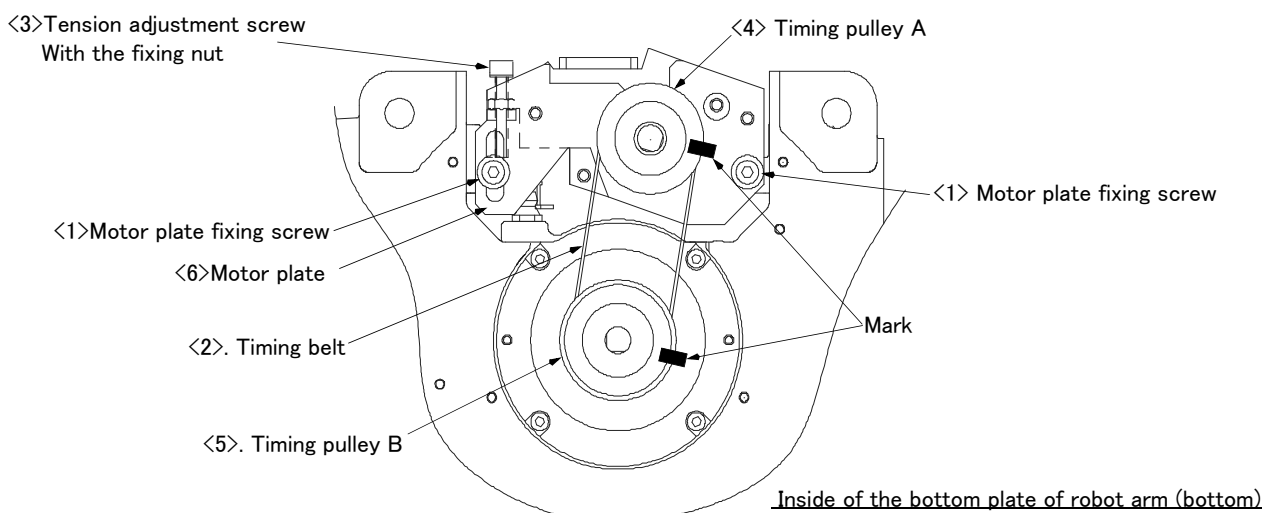

Fig.5-10 : Replacing the J1 axis timing belt (RV-2FR series)

- 1) Turn the J1 axis to the front by jog operation beforehand. (joint angle is near 0 degree)
- 2) Turn off the robot controller.
- 3) Remove the machine cable or piping, etc. corresponding to the usage condition, and place the robot on the floor sideways. Turn J1 motor cover upward, and place sideways slowly so that a shock may not be given to the robot arm.
- 4) Refer to [Page 103, "5.3.2 Installing/removing the cover"](#) and remove the J1 motor cover and the bottom plate with.
- 5) The image figure inside the bottom plate of the robot arm is shown in [Fig. 5-10](#).
- 6) Make sure that the pulleys do not move while replacing the belt. If the timing pulley A <4> and the timing pulley B <5> position relation deviates, the position could deviate.
- 7) Make marks on the timing belt <2> and timing pulleys <4> and <5> with a felt-tip pen as shown in [Fig. 5-10](#) so that the engagement of the timing belt <2> and timing pulleys <4> and <5> does not deviate.
- 8) Lightly loosen the motor plate fixing screw <1>. (two pc.) (Do not loosen too much.)
- 9) Loosen the nut fixing tension adjustment screw <3>. Loosen the tension adjustment screw <3>, and remove the old belt.
- 10) Copy the marks onto the new timing belt. Make sure that both belts are tense when making the marks.
- 11) Align the new timing belt with the marks on the timing pulleys <4> and <5>, and install.
- 12) Turn tension adjustment screw <3>, and adjust the tension of timing belt <2>.

When the screw is turned to the right, the belt will be stretched, and when turned to the left, will loosen. Adjust the belt tension slack to within the range as shown in [Page 139, "\(15\) Timing belt tension"](#). Before the tension measurement, rotate the timing pulley at least three times in each direction so that the timing belt fits in the pulley. Check the tension measurement method in [Page 111, "\(2\) Timing belt tension measurement"](#).

If the belt is loosened too much when adjusting the tension causing it to come off the timing pulleys <4> and <5>, or if the belt and pulley teeth engagement is deviated, the machine system's origin will deviate.
- 13) After adjustment fastens the fixing nut of tension adjustment screw <3>, and certainly fixes tension adjustment screw <3>. Moreover, also fasten two motor plate fixing screws <1> certainly (M4 screw: tightening torque is 4.51 Nm). Improper tightening can cause the belt to loosen with vibration.
- 14) Install the J1 motor cover and the bottom plate securely as before and finish adjustment.
- 15) Reinstall the robot arm just as before.
- 16) Refer to [Page 155, "5.6 Resetting the origin"](#), and reset the origin position.
- 17) When the maintenance forecast function is valid, reset the accumulation data about the belt. Reset by the dedicated screen or parameter MFBRST of RT ToolBox3. Refer to "RT ToolBox3/RT ToolBox3 mini User's Manual" for operation of RT3 and refer to "Instruction Manual/Detailed Explanation of Functions and Operations" for the parameter.

(4) RV-2FR series: Inspection and replacement of J2-axis timing belt

The reference figure at inspection and replacement of the timing belt is shown in Fig. 5-11.

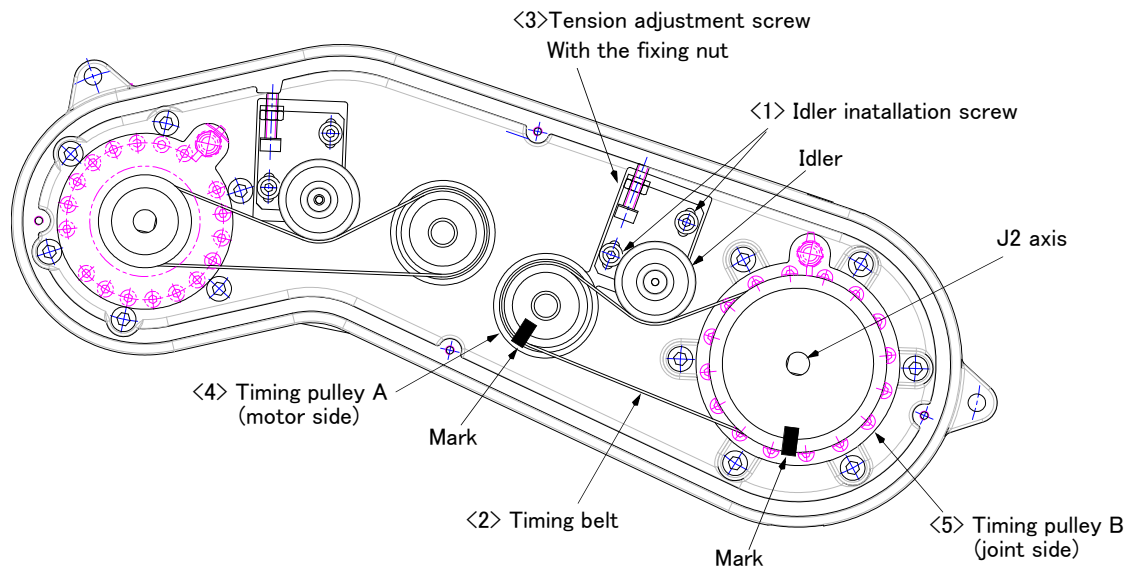

Fig.5-11 : Inspection and replacement of J2 axis timing belt (RV-2FR series)

■ Inspecting the J2 axis timing belt

- 1) Refer to [Page 103, "5.3.2 Installing/removing the cover"](#), and remove the No. 1 arm cover L.
- 2) Visually confirm that the symptoms indicated in [Page 110, "\(1\) Timing belt replacement period"](#) have not occurred with the timing belt <2>.
- 3) Refer to [Page 111, "\(2\) Timing belt tension measurement"](#), and confirm the belt tension.
- 4) Install the No. 1 arm cover L securely as before and finish inspection.

■ Replacing the J2 axis timing belt



CAUTION

It is possible for the customer to replace the timing belt, but precise adjustment is needed to prevent malfunction of the relevant parts. To ask for replacement of the timing belt, contact the dealer.

- 1) Refer to [Page 103, "5.3.2 Installing/removing the cover"](#), and remove the No. 1 arm cover L.
- 2) Make sure that the pulleys do not move while replacing the belt. If the timing pulley <4> and <5> position relation deviates, the position could deviate.
- 3) Make marks on the timing belt <2> and timing pulleys A <4> and B <5> with a felt-tip pen as shown in [Fig. 5-11](#) so that the engagement of the timing belt <2> and timing pulleys <4> and <5> does not deviate.
- 4) Lightly loosen the two idler installation screws <1>. (Do not loosen too much.)
- 5) Loosen the nut fixing tension adjustment screw <3>. Loosen the tension adjustment screw <3>, and remove the old belt.
- 6) Copy the marks onto the new timing belt. Make sure that both belts are tense when making the marks.
- 7) Align the new timing belt with the marks on the timing pulleys <4> and <5>, and install.
- 8) Turn tension adjustment screw <3>, and adjust the tension of timing belt <2>.

When the screw is turned to the right, the belt will be stretched, and when turned to the left, will loosen. Adjust the belt tension slack to within the range as shown in [Page 139, "\(15\) Timing belt tension"](#). Before the tension measurement, rotate the timing pulley at least three times in each direction so that the timing belt fits in the pulley. Check the tension measurement method in [Page 111, "\(2\) Timing belt tension measurement"](#).

If the belt is loosened too much when adjusting the tension causing it to come off the timing pulleys <4> and <5>, or if the belt and pulley teeth engagement is deviated, the machine system's origin will deviate.
- 9) After adjustment fastens the fixing nut of tension adjustment screw <3>, and certainly fixes tension adjustment screw <3>. Moreover, also fasten two idler installation screws <1> certainly (M3 screw: tightening torque is 1.96 Nm). Improper tightening can cause the belt to loosen with vibration.
- 10) Install the No. 1 arm cover L securely as before.

- 11) Refer to [Page 155, "5.6 Resetting the origin"](#), and reset the origin position.
- 12) When the maintenance forecast function is valid, reset the accumulation data about the belt. Reset by the dedicated screen or parameter MFBRST of RT ToolBox3. Refer to "RT ToolBox3/RT ToolBox3 mini User's Manual" for operation of RT3 and refer to "Instruction Manual/Detailed Explanation of Functions and Operations" for the parameter.

(5) RV-2FR series: Inspection and replacement of J3-axis timing belt

The reference figure at inspection, and replacement of the timing belt is shown in Fig. 5-12.

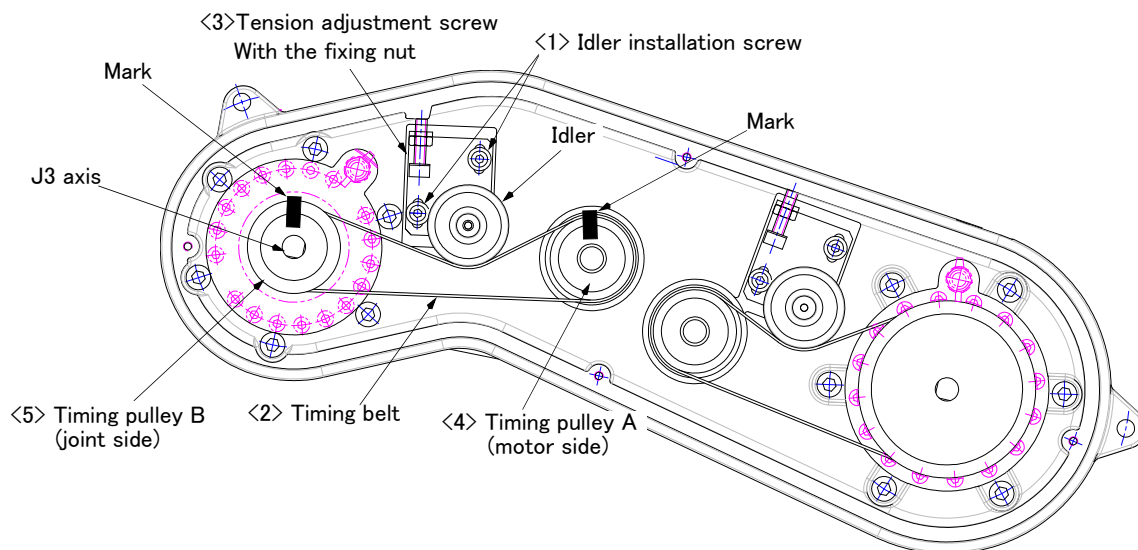

Fig.5-12 : Inspection and replacement of J3 axis timing belt (RV-2FR series)

■ Inspecting the J3 axis timing belt

- 1) Refer to [Page 103, "5.3.2 Installing/removing the cover"](#), and remove the No. 1 arm cover L.
- 2) Visually confirm that the symptoms indicated in [Page 110, "\(1\) Timing belt replacement period"](#) have not occurred with the timing belt <2>.
- 3) Refer to [Page 111, "\(2\) Timing belt tension measurement"](#), and confirm the belt tension.
- 4) Install the No. 1 arm cover L securely as before and finish inspection.

■ Replacing the J3 axis timing belt



CAUTION

It is possible for the customer to replace the timing belt, but precise adjustment is needed to prevent malfunction of the relevant parts. To ask for replacement of the timing belt, contact the dealer.

- 1) Refer to [Page 103, "5.3.2 Installing/removing the cover"](#), and remove the No. 1 arm cover L.
- 2) Make sure that the pulleys do not move while replacing the belt. If the timing pulley A <4> and B <5> position relation deviates, the position could deviate.
- 3) Make marks on the timing belt <2> and timing pulleys <4> and <5> with a felt-tip pen as shown in [Fig. 5-12](#) so that the engagement of the timing belt <2> and timing pulleys <4> and <5> does not deviate.
- 4) Lightly loosen the two idler installation screws <1>. (Do not loosen too much.)
- 5) Loosen the nut fixing tension adjustment screw <3>. Loosen the tension adjustment screw <3>, and remove the old belt.
- 6) Copy the marks onto the new timing belt. Make sure that both belts are tense when making the marks.
- 7) Align the new timing belt with the marks on the timing pulleys <4> and <5>, and install.
- 8) Turn tension adjustment screw <3>, and adjust the tension of timing belt <2>.

When the screw is turned to the right, the belt will be stretched, and when turned to the left, will loosen. Adjust the belt tension slack to within the range as shown in [Page 139, "\(15\) Timing belt tension"](#). Before the tension measurement, rotate the timing pulley at least three times in each direction so that the timing belt fits in the pulley. Check the tension measurement method in [Page 111, "\(2\) Timing belt tension measurement"](#).

If the belt is loosened too much when adjusting the tension causing it to come off the timing pulleys <4> and <5>, or if the belt and pulley teeth engagement is deviated, the machine system's origin will deviate.
- 9) After adjustment fastens the fixing nut of tension adjustment screw <3>, and certainly fixes tension adjustment screw <3>. Moreover, also fasten two idler installation screws <1> certainly (M3 screw: tightening torque is 1.96 Nm). Improper tightening can cause the belt to loosen with vibration.
- 10) Install the No. 1 arm cover L securely as before.
- 11) Refer to [Page 155, "5.6 Resetting the origin"](#), and reset the origin position.

- 12) When the maintenance forecast function is valid, reset the accumulation data about the belt. Reset by the dedicated screen or parameter MFBRST of RT ToolBox3. Refer to "RT ToolBox3/RT ToolBox3 mini User's Manual" for operation of RT3 and refer to "Instruction Manual/Detailed Explanation of Functions and Operations" for the parameter.

(6) RV-2FR series: Inspection and replacement of J4-axis timing belt

The reference figure at inspection and replacement of the timing belt is shown in Fig. 5-13.

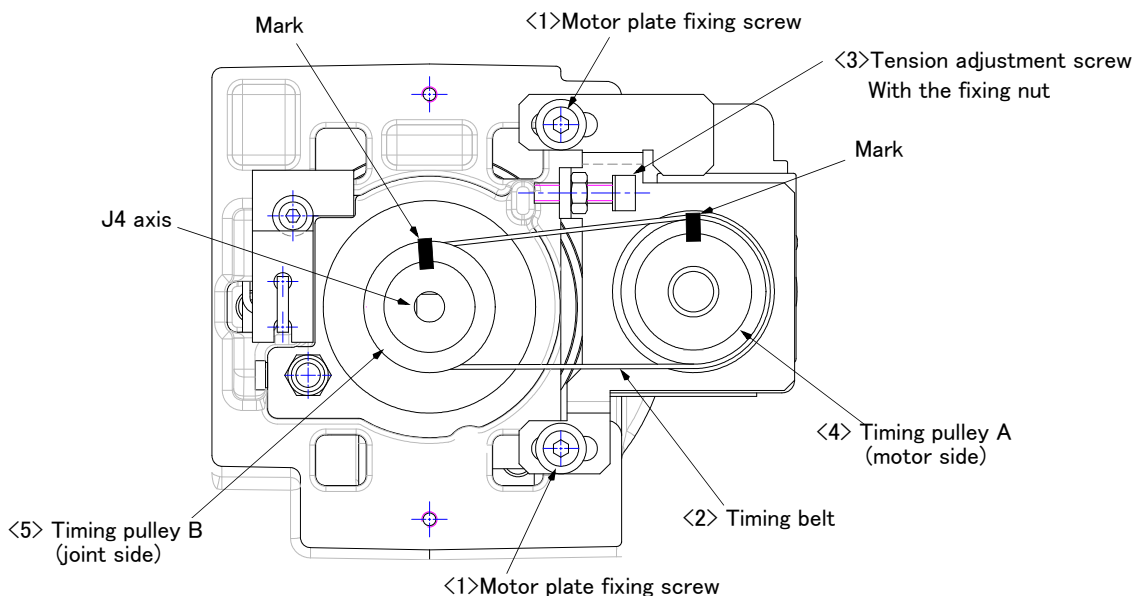

Fig.5-13 : Inspection and replacement of J4 axis timing belt (RV-2FR series)

■ Inspecting the J4 axis timing belt

- 1) Refer to [Page 103, "5.3.2 Installing/removing the cover"](#), and remove the elbow cover B and elbow cover R.
- 2) Visually confirm that the symptoms indicated in [Page 110, "\(1\) Timing belt replacement period"](#) have not occurred with the timing belt.
- 3) Refer to [Page 111, "\(2\) Timing belt tension measurement"](#), and confirm the belt tension.
- 4) Install the elbow cover B and elbow cover R securely as before and finish inspection.

■ Replacing the J4 axis timing belt



CAUTION

It is possible for the customer to replace the timing belt, but precise adjustment is needed to prevent malfunction of the relevant parts. To ask for replacement of the timing belt, contact the dealer.

- 1) Refer to [Page 103, "5.3.2 Installing/removing the cover"](#), and remove the elbow cover B and elbow cover R.
- 2) Make sure that the pulleys do not move while replacing the belt. If the timing pulley A <4> and B <5> position relation deviates, the position could deviate.
- 3) Make marks on the timing belt <2> and timing pulleys <4> and <5> with a felt-tip pen as shown in [Fig. 5-13](#) so that the engagement of the timing belt <2> and timing pulleys <4> and <5> does not deviate.
- 4) Lightly loosen the two motor plate fixing screws <1>. (Do not loosen too much.)
- 5) Loosen the nut fixing tension adjustment screw <3>. Loosen the tension adjustment screw <3>, and remove the old belt.
- 6) Copy the marks onto the new timing belt. Make sure that both belts are tense when making the marks.
- 7) Align the new timing belt with the marks on the timing pulleys <4> and <5>, and install.
- 8) Turn tension adjustment screw <3>, and adjust the tension of timing belt <2>.

When the screw is turned to the right, the belt will be stretched, and when turned to the left, will loosen. Adjust the belt tension slack to within the range as shown in [Page 139, "\(15\) Timing belt tension"](#). Before the tension measurement, rotate the timing pulley at least three times in each direction so that the timing belt fits in the pulley. Check the tension measurement method in [Page 111, "\(2\) Timing belt tension measurement"](#).

If the belt is loosened too much when adjusting the tension causing it to come off the timing pulleys <4> and <5>, or if the belt and pulley teeth engagement is deviated, the machine system's origin will deviate.
- 9) After adjustment fastens the fixing nut of tension adjustment screw <3>, and certainly fixes tension adjustment screw <3>. Moreover, also fasten two motor plate fixing screws <1> certainly (M4 screw: tightening torque is 4.51 Nm). Improper tightening can cause the belt to loosen with vibration.
- 10) Install the elbow cover B and elbow cover R securely as before.

- 11) Refer to [Page 155](#), "5.6 Resetting the origin", and reset the origin position.
- 12) When the maintenance forecast function is valid, reset the accumulation data about the belt. Reset by the dedicated screen or parameter MFBRST of RT ToolBox3. Refer to "RT ToolBox3/RT ToolBox3 mini User's Manual" for operation of RT3 and refer to "Instruction Manual/Detailed Explanation of Functions and Operations" for the parameter.

(7) RV-2FR series: Inspection and replacement of J5 axis timing belt and brake timing belt

The J5 axis has the timing belt rotating the J5 axis and the brake timing belt conveying the brake. The inspection and replacement method of each belt is shown below.

A) Inspection, maintenance and replacement of J5-axis timing belt

The reference figure at inspection and replacement of the timing belt is shown in Fig. 5-14.

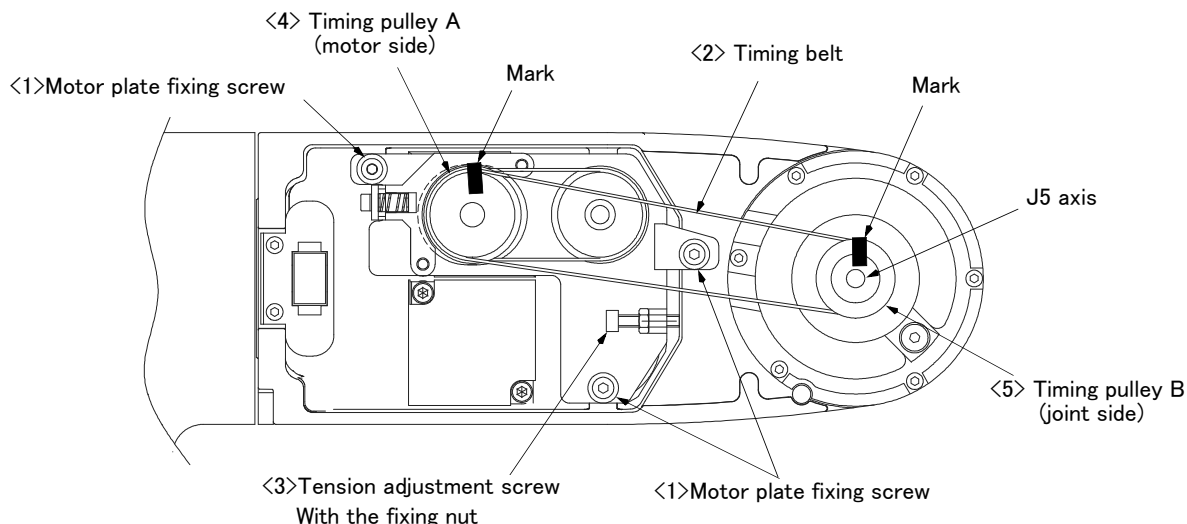

Fig.5-14 : Inspection and replacement of J5 axis timing belt (RV-2FR series)

■ Inspecting the J5 axis timing belt

- 1) Refer to [Page 103, "5.3.2 Installing/removing the cover"](#), and remove the No. 2 arm cover R.
- 2) Visually confirm that the symptoms indicated in [Page 110, "\(1\) Timing belt replacement period"](#) have not occurred with the timing belt.
- 3) Refer to [Page 111, "\(2\) Timing belt tension measurement"](#), and confirm the belt tension.
- 4) Install the No. 2 arm cover R securely as before and finish inspection.

■ Replacing the J5 axis timing belt



CAUTION

It is possible for the customer to replace the timing belt, but precise adjustment is needed to prevent malfunction of the relevant parts. To ask for replacement of the timing belt, contact the dealer.

- 1) Refer to [Page 103, "5.3.2 Installing/removing the cover"](#), and remove the No. 2 arm cover R.
- 2) Make sure that the pulleys do not move while replacing the belt. If the timing pulley A <4> and B <5> position relation deviates, the position could deviate.
- 3) Make marks on the timing belt <2> and timing pulleys <4> and <5> with a felt-tip pen as shown in [Fig. 5-14](#) so that the engagement of the timing belt <2> and timing pulleys <4> and <5> does not deviate.
- 4) Lightly loosen the three motor plate fixing screws <1>. (Do not loosen too much.)
- 5) Loosen the nut fixing tension adjustment screw <3>. Loosen the tension adjustment screw <3>, and remove the old belt.
- 6) Copy the marks onto the new timing belt. Make sure that both belts are tense when making the marks.
- 7) Align the new timing belt with the marks on the timing pulleys <4> and <5>, and install.
- 8) Turn tension adjustment screw <3>, and adjust the tension of timing belt <2>.

When the screw is turned to the right, the belt will be stretched, and when turned to the left, will loosen.

Adjust the belt tension slack to within the range as shown in [Page 139, "\(15\) Timing belt tension"](#).

Before the tension measurement, rotate the timing pulley at least three times in each direction so that the timing belt fits in the pulley. Check the tension measurement method in [Page 111, "\(2\) Timing belt tension measurement"](#).

If the belt is loosened too much when adjusting the tension causing it to come off the timing pulleys <4> and <5>, or if the belt and pulley teeth engagement is deviated, the machine system's origin will deviate.

- 9) After adjustment fastens the fixing nut of tension adjustment screw <3>, and certainly fixes tension adjustment screw <3>. Moreover, also fasten the three motor plate fixing screws <1> certainly (M4 screw: tightening torque is 4.51Nm). Improper tightening can cause the belt to loosen with vibration.
- 10) Install the No. 2 arm cover R securely as before.
- 11) Refer to [Page 155, "5.6 Resetting the origin"](#), and reset the origin position.
- 12) When the maintenance forecast function is valid, reset the accumulation data about the belt. Reset by the dedicated screen or parameter MFBRST of RT ToolBox3. Refer to "RT ToolBox3/RT ToolBox3 mini User's Manual" for operation of RT3 and refer to "Instruction Manual/Detailed Explanation of Functions and Operations" for the parameter.

B) Inspection and replacement of J5 axis brake timing belt

The reference figure at inspection and replacement of the brake timing belt is shown in Fig. 5-15.

To replace the J5 axis brake timing belt, remove the J5 axis timing belt. Measure the tension before removing the J5 axis timing belt, and reinstall the belt so that the tension must be the same as the one measured before removal.

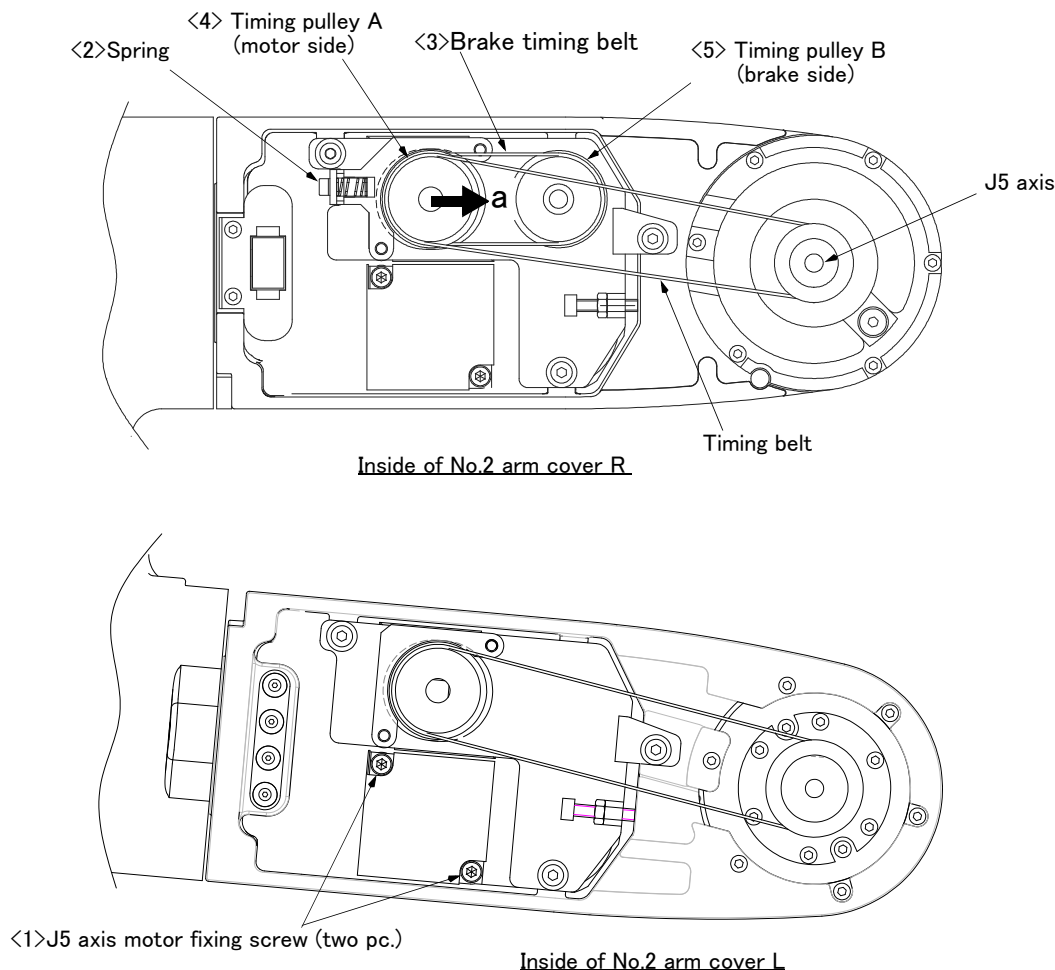

Fig.5-15 : Inspection and replacement of J5 axis brake timing belt (RV-2FR series)

■ Inspecting the J5 axis brake timing belt

- 1) Refer to Page 103, "5.3.2 Installing/removing the cover", and remove the No. 2 arm cover R and L.
- 2) Visually confirm that the symptoms indicated in Page 110, "(1) Timing belt replacement period" have not occurred with the timing belt.
- 3) Refer to Page 111, "(2) Timing belt tension measurement", and confirm the belt tension.
- 4) Install the No. 2 arm cover R and L securely as before and finish inspection.

■ Replacing the J5 axis brake timing belt



CAUTION

It is possible for the customer to replace the timing belt, but precise adjustment is needed to prevent malfunction of the relevant parts. To ask for replacement of the timing belt, contact the dealer.

- 1) Refer to Page 103, "5.3.2 Installing/removing the cover", and remove the No. 2 arm cover R and L.
- 2) Remove J5 axis timing belt with referring to above " ■ Replacing the J5 axis timing belt".
- 3) Loosen the two motor fixing screws <1>. (Do not loosen too much.)
- 4) Move motor side timing belt pulley (4) in the direction of the arrow "a" of Fig. 5-15 , and remove the brake timing belt..
- 5) Install the new brake timing belt. The operations of matching the position for brake timing belt is unnecessary.

- 6) After replacement, securely tighten the two motor installation screws <1> (M4 screw: tightening torque is 4.51 Nm). (Tension is automatically adjusted by the work of the spring.) Improper tightening can cause the belt to loosen with vibration.
- 7) Install J5 axis timing belt with reference to above " ■ Replacing the J5 axis timing belt", and adjust tension.

(8) RV-2FR series: Inspection and replacement of J6-axis timing belt and brake timing belt

The reference figure at inspection and replacement of the timing belt is shown in Fig. 5-16.

In the RV-2FRB/2FRLB, the J6 axis has the timing belt rotating the J6 axis and the brake timing belt conveying the brake. Also inspection and replacement the brake timing belt simultaneously.

A) Inspection, maintenance and replacement of J6-axis timing belt

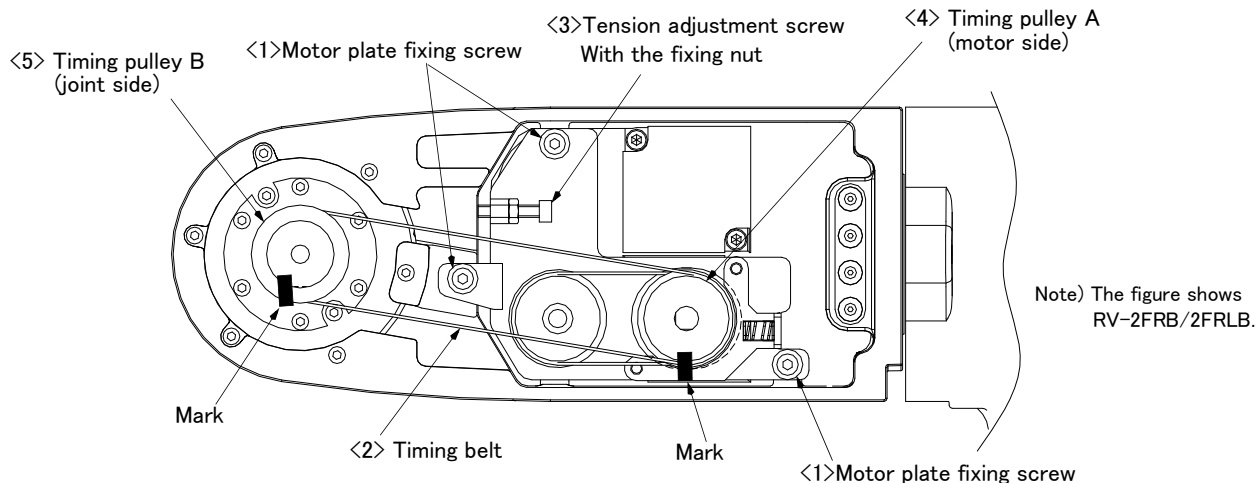

Fig.5-16 : Inspection and replacement of J6 axis timing belt (RV-2FR series)

■ Inspecting the J6 axis timing belt

- 1) Refer to Page 103, "5.3.2 Installing/removing the cover", and remove the No. 2 arm cover L.
- 2) Visually confirm that the symptoms indicated in Page 110, "(1) Timing belt replacement period" have not occurred with the timing belt.
- 3) Refer to Page 111, "(2) Timing belt tension measurement", and confirm the belt tension.
- 4) Install the No. 2 arm cover L securely as before and finish inspection.

■ Replacing the J6 axis timing belt



CAUTION

It is possible for the customer to replace the timing belt, but precise adjustment is needed to prevent malfunction of the relevant parts. To ask for replacement of the timing belt, contact the dealer.

- 1) Refer to Page 103, "5.3.2 Installing/removing the cover", and remove the No. 2 arm cover L.
- 2) Make sure that the pulleys do not move while replacing the belt. If the pulley <4> and <5> position relation deviates, the position could deviate.
- 3) Make marks on the timing belt <2> and timing pulleys <4> and <5> with a felt-tip pen as shown in Fig. 5-16 so that the engagement of the timing belt <2> and timing pulleys <4> and <5> does not deviate.
- 4) Lightly loosen the three motor plate fixing screws <1>. (Do not loosen too much.)
- 5) Loosen the nut fixing tension adjustment screw <3>. Loosen the tension adjustment screw <3>, and remove the old belt.
- 6) Copy the marks onto the new timing belt. Make sure that both belts are tense when making the marks.
- 7) Align the new timing belt with the marks on the timing pulleys <4> and <5>, and install.
- 8) Turn tension adjustment screw <3>, and adjust the tension of timing belt <2>.

When the screw is turned to the right, the belt will be stretched, and when turned to the left, will loosen.

Adjust the belt tension slack to within the range as shown in Page 139, "(15) Timing belt tension".

Before the tension measurement, rotate the timing pulley at least three times in each direction so that the timing belt fits in the pulley. Check the tension measurement method in Page 111, "(2) Timing belt tension measurement".

If the belt is loosened too much when adjusting the tension causing it to come off the timing pulleys <4> and <5>, or if the belt and pulley teeth engagement is deviated, the machine system's origin will deviate.

- 9) After adjustment fastens the fixing nut of tension adjustment screw <3>, and certainly fixes tension adjustment screw <3>. Moreover, also fasten the three motor plate fixing screws <1> certainly (M4 screw: tightening torque is 4.51 Nm). Improper tightening can cause the belt to loosen with vibration.

- 10) Install the No. 2 arm cover L securely as before.
- 11) Refer to [Page 155](#), "5.6 Resetting the origin", and reset the origin position.
- 12) When the maintenance forecast function is valid, reset the accumulation data about the belt. Reset by the dedicated screen or parameter MFBRST of RT ToolBox3. Refer to "RT ToolBox3/RT ToolBox3 mini User's Manual" for operation of RT3 and refer to "Instruction Manual/Detailed Explanation of Functions and Operations" for the parameter.

B) Inspection and replacement of J6 axis brake timing belt

The reference figure at inspection and replacement of the brake timing belt is shown in Fig. 5-17. To replace the J6 axis brake timing belt, remove the J6 axis timing belt. Measure the tension before removing the J6 axis timing belt, and reinstall the belt so that the tension must be the same as the one measured before removal.

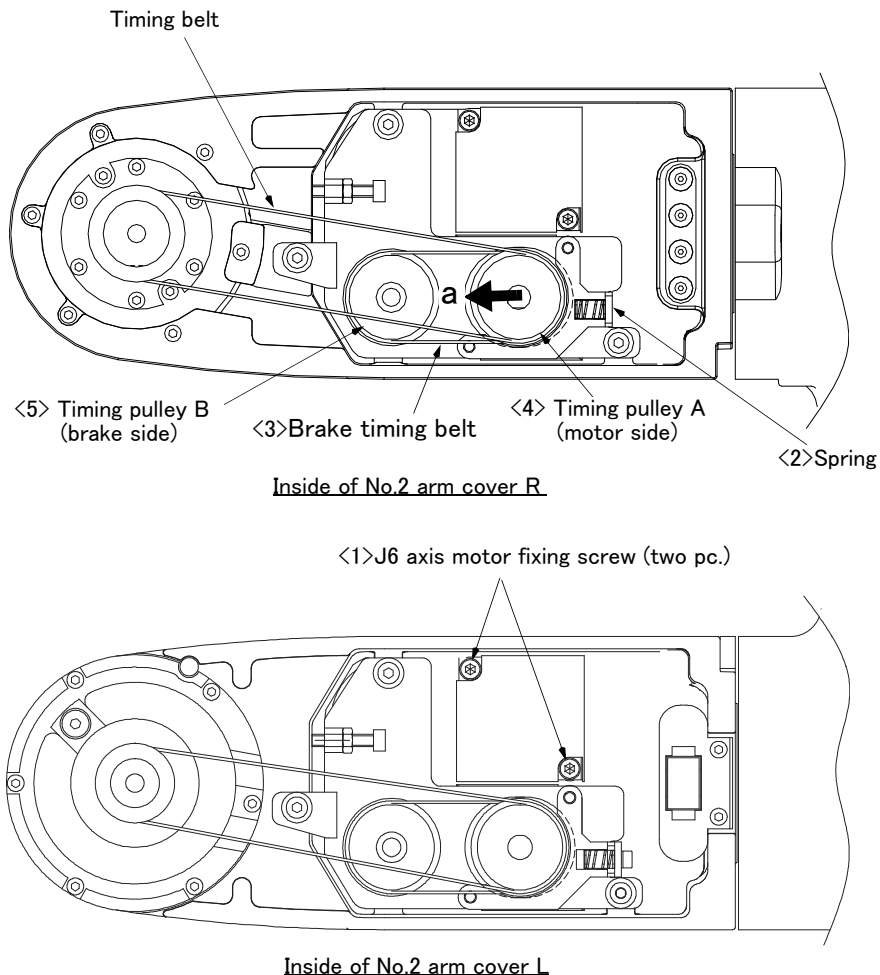

Fig.5-17 : Inspection and replacement of J6 axis brake timing belt (RV-2FRB/2FRLB)

■ Inspecting the J6 axis brake timing belt

- 1) Refer to Page 103, "5.3.2 Installing/removing the cover", and remove the No. 2 arm cover R and L.
- 2) Visually confirm that the symptoms indicated in Page 110, "(1) Timing belt replacement period" have not occurred with the timing belt.
- 3) Refer to Page 111, "(2) Timing belt tension measurement", and confirm the belt tension.
- 4) Install the No. 2 arm cover R and L securely as before and finish inspection.

■ Replacing the J6 axis brake timing belt

CAUTION

It is possible for the customer to replace the timing belt, but precise adjustment is needed to prevent malfunction of the relevant parts. To ask for replacement of the timing belt, contact the dealer.

- 1) Refer to Page 103, "5.3.2 Installing/removing the cover", and remove the No. 2 arm cover R and L.
- 2) Remove J6 axis timing belt with referring to above " ■ Replacing the J6 axis timing belt".
- 3) Loosen the two motor fixing screws <1>. (two pc.) (Do not loosen too much.)
- 4) Move motor side timing belt pulley <4> in the direction of the arrow "a" of Fig. 5-17, and remove the brake timing belt.
- 5) Install the new brake timing belt. The operations of matching the position for brake timing belt is unnecessary.

- 6) After replacement, securely tighten the two motor installation screws <1> (M4 screw: tightening torque is 4.51 Nm). (Tension is automatically adjusted by the work of the spring.) Improper tightening can cause the belt to loosen with vibration.
- 7) Install J6 axis timing belt with reference to above " ■ Replacing the J6 axis timing belt", and adjust tension.

(9) RV-4FR/7FR series: Inspection and replacement of J1-axis timing belt

The reference figure at inspection and replacement of the timing belt is shown in Fig. 5-18.

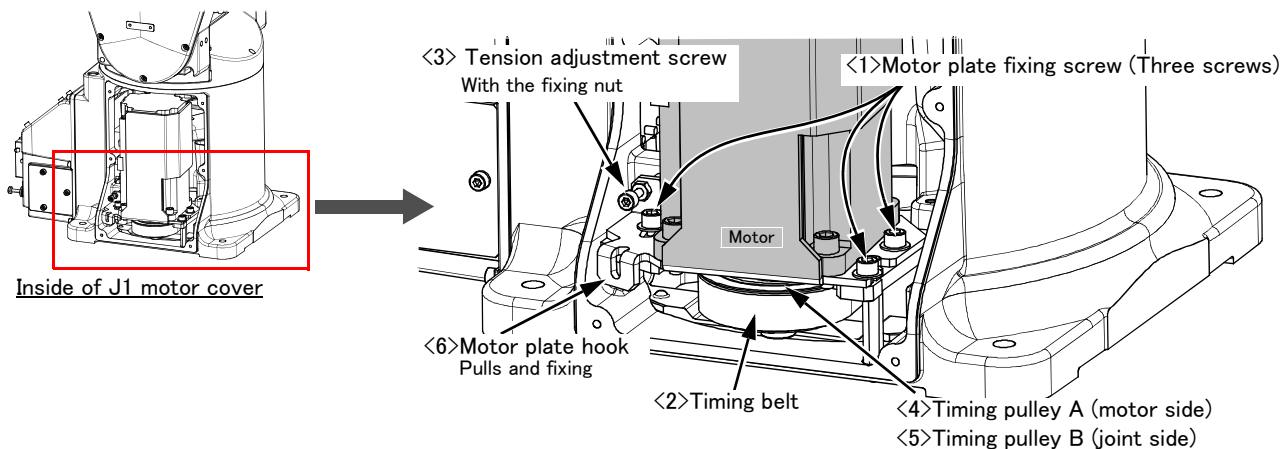

Fig.5-18 : Inspection, maintenance and replacement of J1 axis timing belt (RV-4FR/7FR series)

■ Inspecting the J1 axis timing belt

- 1) Refer to Page 103, "5.3.2 Installing/removing the cover", and remove the J1 motor cover.
- 2) Visually confirm that the symptoms indicated in Page 110, "(1) Timing belt replacement period" have not occurred with the timing belt.
- 3) Refer to Page 111, "(2) Timing belt tension measurement", and confirm the belt tension.
- 4) Install the J1 motor cover securely as before and finish inspection.

■ Replacing the J1 axis timing belt

CAUTION Make sure that the pulleys do not move while replacing the belt. If the pulley A <4> and B <5> position relation deviates, the position could deviate.

CAUTION It is possible for the customer to replace the timing belt, but precise adjustment is needed to prevent malfunction of the relevant parts. To ask for replacement of the timing belt, contact the dealer.

- 1) Refer to Page 103, "5.3.2 Installing/removing the cover", and remove the J1 motor cover.
- 2) Loosen the nut of the tension adjustment screw <3>, and loosen the tension adjustment screw <3>.
- 3) Remove the three motor plate fixing screws <1>, and remove the timing belt <2> from the timing pulley A <4>.
- 4) Remove the J1 axis motor, and remove the timing belt <2>.
- 5) Install the new timing belt to the timing pulley B <5> and timing pulley A <4>, and install the J1 axis motor to the original position by the motor plate fixing screws <1>.
- 6) Lightly loosen the three motor plate fixing screws <1>. (Do not loosen too much.)
- 7) Loosen the nut fixing tension adjustment screw <3>. And lightly loosen tension adjustment screw <3>.
- 8) Refer to the following and tighten the three motor plate fixing screws <1> while pulling the motor plate hook <6>.

Model	Hook pulling force [N]		Motor plate fixing screw <1> Size: Tightening torque
	Existing belt	New belt	
RV-4FR series	53 to 65	80 to 98	M4: 4.51Nm
RV-7FR series	64 to 78	91 to 112	M5: 9.31Nm

The tension of J1 axis timing belt is adjusted with this method. Certainly fix the three motor plate fixing screws <1>. Improper tightening can cause the belt to loosen with vibration.

If the belt is loosened too much when adjusting the tension causing it to come off the timing pulleys <4> and <5>, or if the belt and pulley teeth engagement is deviated, the machine system's origin will deviate.

- 9) After adjustment fastens the fixing nut of tension adjustment screw <3>, and certainly fixes tension adjustment screw <3>. Moreover, also fasten the three motor plate fixing screws <1> certainly (M4 screw: tightening torque is 4.51 Nm). Improper tightening can cause the belt to loosen with vibration.
- 10) Check that the belt tension meets the value in [Page 139, "\(15\) Timing belt tension"](#).
Before the tension measurement, rotate the timing pulley at least three times in each direction so that the timing belt fits in the pulley. Check the tension measurement method in [Page 111, "\(2\) Timing belt tension measurement"](#).
If the belt is loosened too much when adjusting the tension causing it to come off the timing pulleys <4> and <5>, or if the belt and pulley teeth engagement is deviated, the machine system's origin will deviate.
- 11) Install the J1 motor cover securely as before.
- 12) Refer to [Page 155, "5.6 Resetting the origin"](#), and reset the origin position.
- 13) When the maintenance forecast function is valid, reset the accumulation data about the belt. Reset by the dedicated screen or parameter MFBRST of RT ToolBox3. Refer to "RT ToolBox3/RT ToolBox3 mini User's Manual" for operation of RT3 and refer to "Instruction Manual/Detailed Explanation of Functions and Operations" for the parameter.

(10) RV-4FR/7FR series: Inspection and replacement of J3-axis timing belt

The reference figure at inspection and replacement of the timing belt is shown in Fig. 5-19.

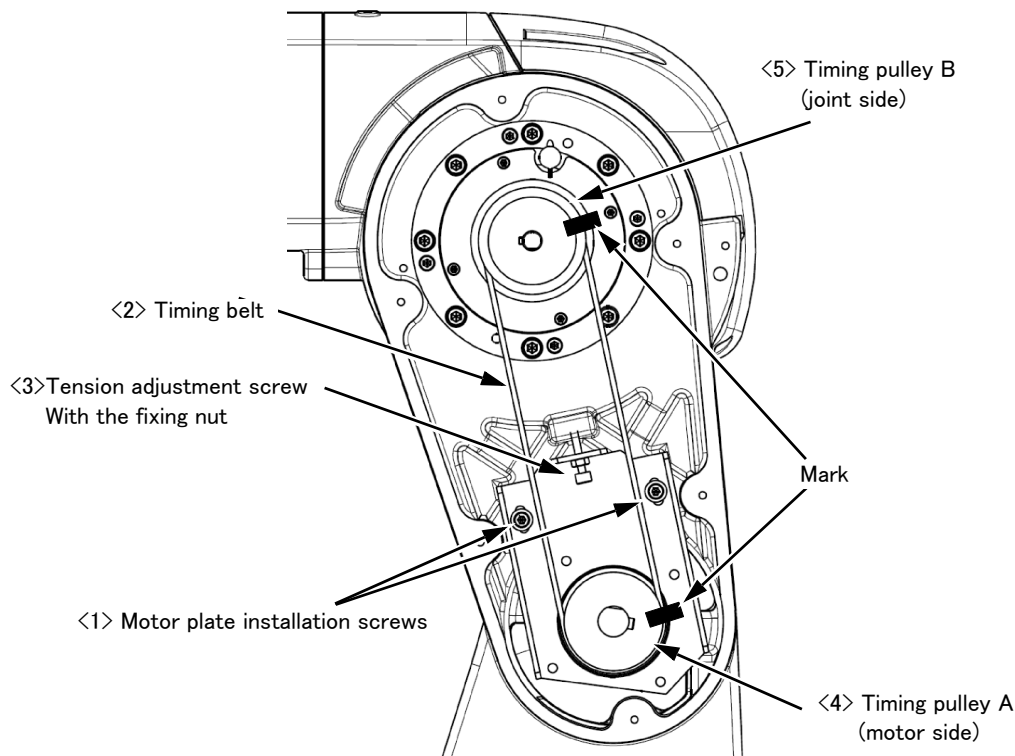

Fig.5-19 : Inspection and replacement of J3 axis timing belt (RV-4FR/7FR series)

■ Inspecting the J3 axis timing belt

- 1) Refer to [Page 103, "5.3.2 Installing/removing the cover"](#), and remove the No. 1 arm cover L.
- 2) Visually confirm that the symptoms indicated in [Page 110, "\(1\) Timing belt replacement period"](#) have not occurred with the timing belt <2>.
- 3) Refer to [Page 111, "\(2\) Timing belt tension measurement"](#), and confirm the belt tension.
- 4) Install the No. 1 arm cover L securely as before and finish inspection.

■ Replacing the J3 axis timing belt (RV-4FR series)



CAUTION

If the timing belt of the J3 axis is removed, the forearm will drop by the self-weight. And, if the positional relation between the timing pulley A <4> and B <5> deviated, it will become the cause of the position deviation. For the safety before replacing the timing belts, hit the J3 axis against mechanical stopper with releasing brake.



CAUTION

It is possible for the customer to replace the timing belt, but precise adjustment is needed to prevent malfunction of the relevant parts. To ask for replacement of the timing belt, contact the dealer.

- 1) Refer to [Page 103, "5.3.2 Installing/removing the cover"](#), and remove the No. 1 arm cover L and No.1 arm cover U.
- 2) Remove the heat conduction sheet A stuck on the J3 axis motor (see [Fig. 5-20](#)). Be careful not to get any dust, etc. on the adhesive side.
- 3) Make sure that the pulleys do not move while replacing the belt. If the timing pulley A <4> and B <5> position relation deviates, the position could deviate.
Be careful not to shift the heat conduction sheet B (see [Fig. 5-20](#)).
- 4) Make marks on the timing belt <2> and timing pulleys <4> and <5> with a felt-tip pen as shown in [Fig. 5-19](#) so that the engagement of the timing belt <2> and timing pulleys <4> and <5> does not deviate.
- 5) Lightly loosen the two motor plate installation screws <1>. (Do not loosen too much.)

- 6) Loosen the nut fixing tension adjustment screw <3>. Loosen the tension adjustment screw <3>, and remove the old belt.
- 7) Copy the marks onto the new timing belt. Make sure that both belts are tense when making the marks.
- 8) Align the new timing belt with the marks on the timing pulleys <4> and <5>, and install.
- 9) Turn tension adjustment screw <3>, and adjust the tension of timing belt <2>.

When the screw is turned to the right, the belt will be stretched, and when turned to the left, will loosen. Adjust the belt tension slack to within the range as shown in [Page 139, "\(15\) Timing belt tension"](#).

Before the tension measurement, rotate the timing pulley at least three times in each direction so that the timing belt fits in the pulley. Check the tension measurement method in [Page 111, "\(2\) Timing belt tension measurement"](#).

If the belt is loosened too much when adjusting the tension causing it to come off the timing pulleys <4> and <5>, or if the belt and pulley teeth engagement is deviated, the machine system's origin will deviate.

- 10) After adjustment fastens the fixing nut of tension adjustment screw <3>, and certainly fixes tension adjustment screw <3>. Moreover, also fasten the two motor plate fixing screws <1> certainly (M4 screw: tightening torque is 4.51 Nm). Improper tightening can cause the belt to loosen with vibration.
- 11) Stick the adhesive side of heat conduction sheet A to the J3 axis motor. If the heat conduction sheet A is damaged, please replace it.
- 12) Install the No. 1 arm cover L and No.1 arm cover U securely as before.
(Some RV-4FRL may have a protrusion (as shown below) on the No. 1 arm cover U. In this case, install the cover by slipping the protrusion beneath the heat conduction sheet A not to bend the sheet.)



- 13) Refer to [Page 155, "5.6 Resetting the origin"](#), and reset the origin position.
- 14) When the maintenance forecast function is valid, reset the accumulation data about the belt. Reset by the dedicated screen or parameter MFBRST of RT ToolBox3. Refer to "RT ToolBox3/RT ToolBox3 mini User's Manual" for operation of RT3 and refer to "Instruction Manual/Detailed Explanation of Functions and Operations" for the parameter.

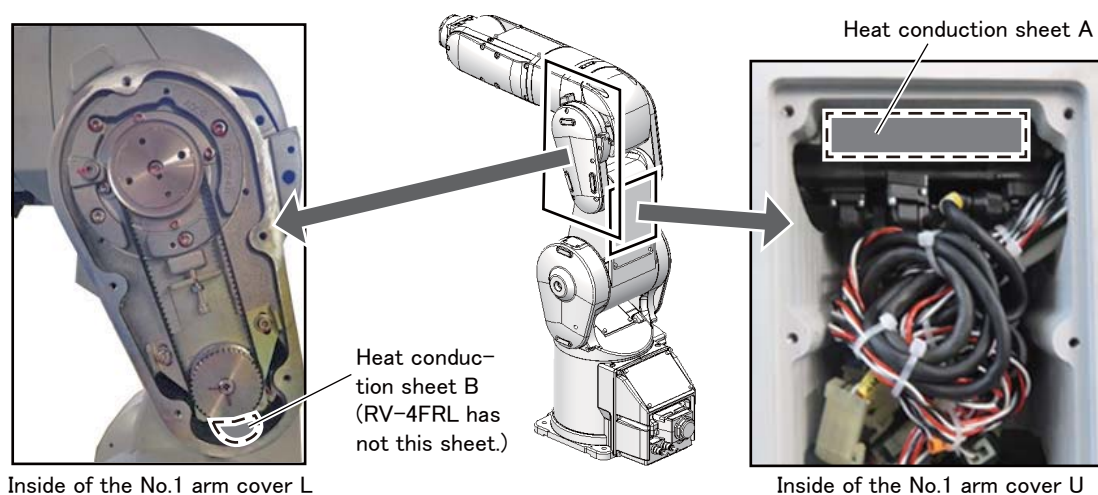

Fig.5-20 : Heat conduction sheet position

■ Replacing the J3 axis timing belt (RV-7FR series)



CAUTION

If the timing belt of the J3 axis is removed, the forearm will drop by the self-weight. And, if the positional relation between the timing pulley A <4> and B <5> deviated, it will become the cause of the position deviation. For the safety before replacing the timing belts, hit the J3 axis against mechanical stopper with releasing brake.



CAUTION

It is possible for the customer to replace the timing belt, but precise adjustment is needed to prevent malfunction of the relevant parts. To ask for replacement of the timing belt, contact the dealer.

- 1) Refer to [Page 103, "5.3.2 Installing/removing the cover"](#), and remove the No. 1 arm cover L.
- 2) Make sure that the pulleys do not move while replacing the belt. If the timing pulley A <4> and B <5> position relation deviates, the position could deviate.
- 3) Make marks on the timing belt <2> and timing pulleys <4> and <5> with a felt-tip pen as shown in [Fig. 5-19](#) so that the engagement of the timing belt <2> and timing pulleys <4> and <5> does not deviate.
- 4) Lightly loosen the two motor plate installation screws <1>. (Do not loosen too much.)
- 5) Loosen the nut fixing tension adjustment screw <3>. Loosen the tension adjustment screw <3>, and remove the old belt.
- 6) Copy the marks onto the new timing belt. Make sure that both belts are tense when making the marks.
- 7) Align the new timing belt with the marks on the timing pulleys <4> and <5>, and install.
- 8) Turn tension adjustment screw <3>, and adjust the tension of timing belt <2>.

When the screw is turned to the right, the belt will be stretched, and when turned to the left, will loosen. Adjust the belt tension slack to within the range as shown in [Page 139, "\(15\) Timing belt tension"](#). Before the tension measurement, rotate the timing pulley at least three times in each direction so that the timing belt fits in the pulley. Check the tension measurement method in [Page 111, "\(2\) Timing belt tension measurement"](#).

If the belt is loosened too much when adjusting the tension causing it to come off the timing pulleys <4> and <5>, or if the belt and pulley teeth engagement is deviated, the machine system's origin will deviate.
- 9) After adjustment fastens the fixing nut of tension adjustment screw <3>, and certainly fixes tension adjustment screw <3>. Moreover, also fasten the two motor plate fixing screws <1> certainly (M4 screw: tightening torque is 4.51 Nm). Improper tightening can cause the belt to loosen with vibration.
- 10) Install the No. 1 arm cover L securely as before.
- 11) Refer to [Page 155, "5.6 Resetting the origin"](#), and reset the origin position.
- 12) When the maintenance forecast function is valid, reset the accumulation data about the belt. Reset by the dedicated screen or parameter MFBRST of RT ToolBox3. Refer to "RT ToolBox3/RT ToolBox3 mini User's Manual" for operation of RT3 and refer to "Instruction Manual/Detailed Explanation of Functions and Operations" for the parameter.

- (11) RV-4FR/7FR series (6-axes type): Inspection and replacement of J4-axis timing belt
The reference figure at inspection of the timing belt is shown in Fig. 5-21.

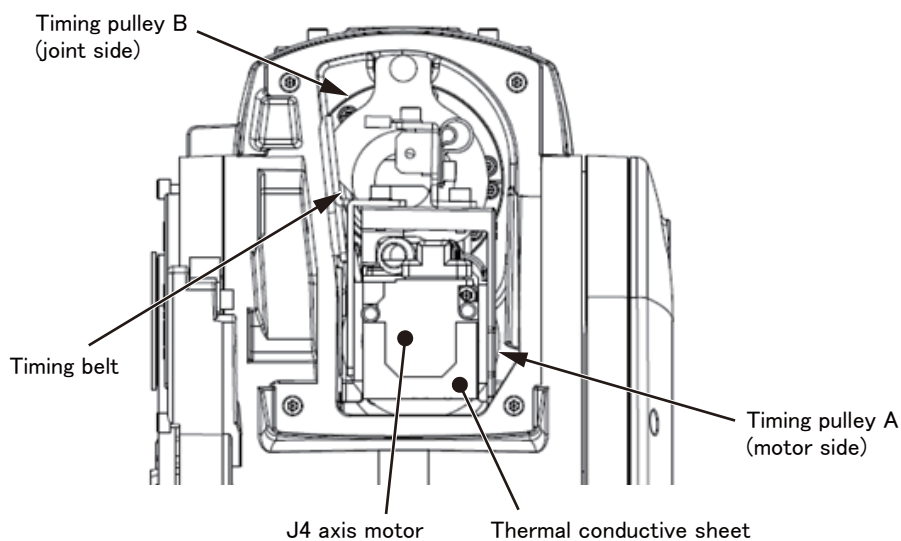

Fig.5-21 : Inspection of J4 axis timing belt (RV-4FR/7FR series)

■ Inspecting the J4 axis timing belt

- 1) Refer to [Page 103](#), "5.3.2 Installing/removing the cover", and remove the elbow cover and No.1 arm cover R.
- 2) In RV-7FR series, remove the cable guide A, B, and C.

Silicon grease is applied to the contact surface of each cable guide to reduce friction or wear caused by movement of the cables. Do not wipe off the silicon grease.

View from the No. 1 arm cover R side

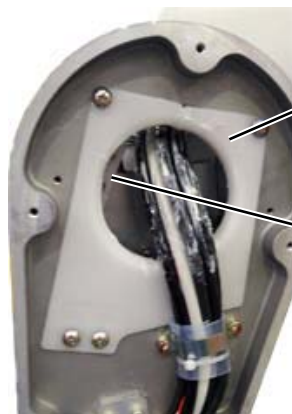

View from the elbow side



- 3) Visually confirm that the symptoms indicated in [Page 110](#), "(1) Timing belt replacement period" have not occurred with the timing belt.
- 4) Refer to [Page 111](#), "(2) Timing belt tension measurement", and confirm the belt tension.
- 5) Install the cable guide A, B, and C securely as before.
- 6) Install the elbow cover and No.1 arm cover R securely as before and finish inspection.

■ Replacing the J4 axis timing belt

For replacement of the timing belt, check the serial numbers of the robot arm and the controller and contact the dealer.

(12) RV-13FR series: Inspection and replacement of J4-axis timing belt

The reference figure at inspection of the timing belt is shown in Fig. 5-22.

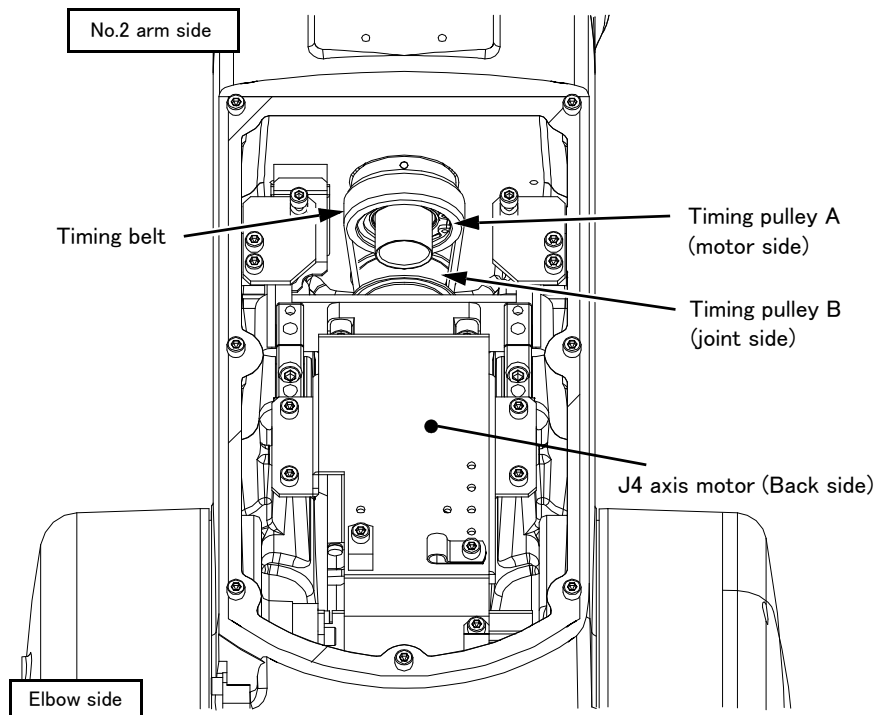

Fig.5-22 : Inspection of J4 axis timing belt (RV-13FR series)

■ Inspecting the J4 axis timing belt

- 1) Refer to [Page 103, "5.3.2 Installing/removing the cover"](#), and remove the elbow cover.
- 2) Visually confirm that the symptoms indicated in [Page 110, "\(1\) Timing belt replacement period"](#) have not occurred with the timing belt.
- 3) Refer to [Page 111, "\(2\) Timing belt tension measurement"](#), and confirm the belt tension.
- 4) Install the elbow cover securely as before and finish inspection.

■ Replacing the J4 axis timing belt

For replacement of the timing belt, check the serial numbers of the robot arm and the controller and contact the dealer.

(13) RV-4FR/7FR/13FR series: Inspection and replacement of J5 axis timing belt

The reference figure at inspection and replacement of the timing belt is shown in Fig. 5-23 (RV-4FR/7FR series, RV-7FRLL) or Fig. 5-24 (RV-13FR/13FRL, and RV-20FR series).

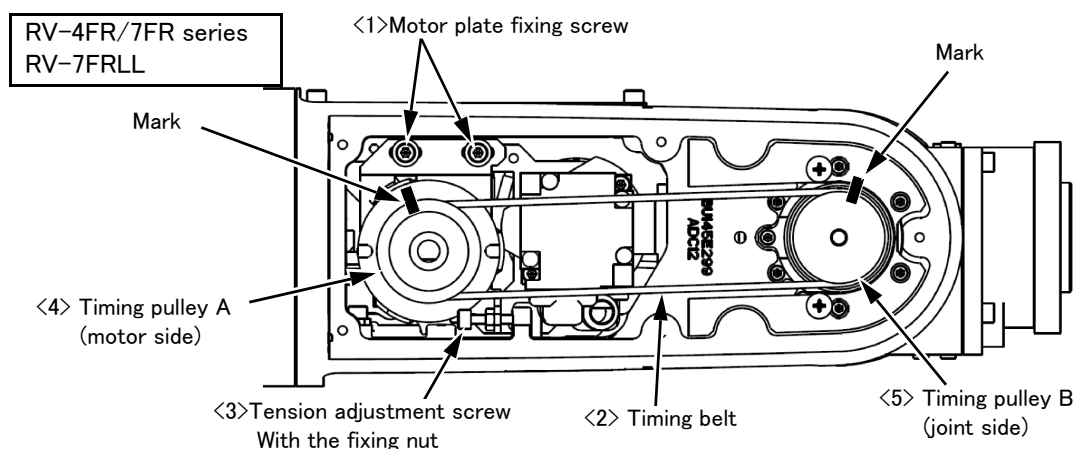

Fig.5-23 : Inspection and replacement of J5 axis timing belt (RV-4FR/7FR series, RV-7FRLL)

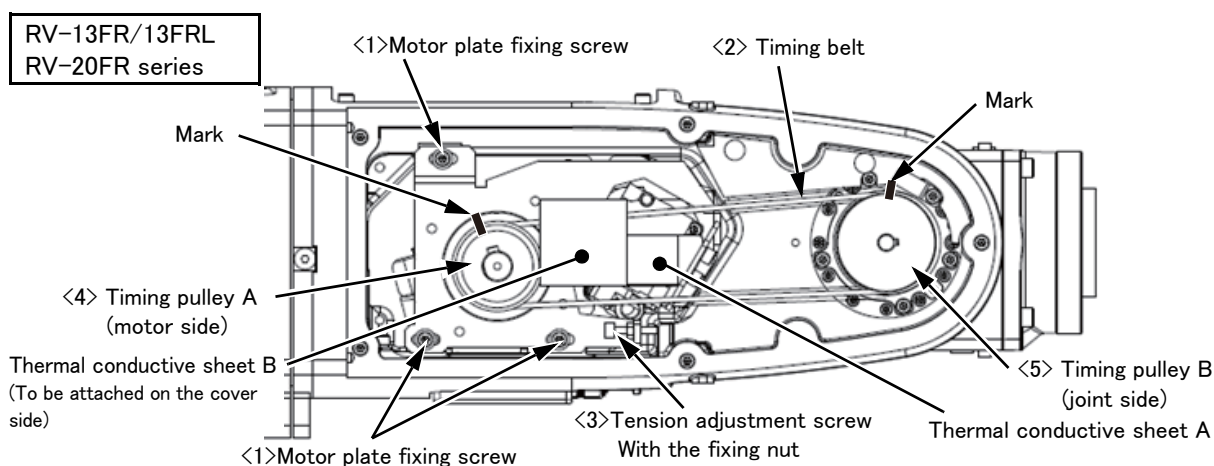

Fig.5-24 : Inspection and replacement of J5 axis timing belt (RV-13FR/13FRL, RV-20FR series)

■ Inspecting the J5 axis timing belt

- 1) Refer to Page 103, "5.3.2 Installing/removing the cover", and remove the No. 2 arm cover R.
- 2) Visually confirm that the symptoms indicated in Page 110, "(1) Timing belt replacement period" have not occurred with the timing belt.
- 3) Refer to Page 111, "(2) Timing belt tension measurement", and confirm the belt tension.
- 4) Install the No. 2 arm cover R securely as before and finish inspection.

■ Replacing the J5 axis timing belt

CAUTION

If the timing belt of the J5 axis is removed, the forearm will drop by the self-weight. (faces in the downward) And, if the positional relation between the timing pulley A <4> and B <5> deviated, it will become the cause of the position deviation. For the safety before replacing the timing belt, move the J3 axis so that it may face in the downward by jog operation.

CAUTION

It is possible for the customer to replace the timing belt, but precise adjustment is needed to prevent malfunction of the relevant parts. To ask for replacement of the timing belt, contact the dealer.

- 1) Refer to Page 103, "5.3.2 Installing/removing the cover", and remove the No. 2 arm cover R.
- 2) Make sure that the pulleys do not move while replacing the belt. If the timing pulley A <4> and B <5> position relation deviates, the position could deviate.

- 3) Make marks on the timing belt <2> and timing pulleys <4> and <5> with a felt-tip pen as shown in the figure above, so that the engagement of the timing belt <2> and timing pulleys <4> and <5> does not deviate.
- 4) Lightly loosen the following motor plate fixing screw <1>. (Do not loosen too much.)

Model	Motor plate fixing screw <1>
RV-4FR/7FR series, RV-7FRL	Two pcs.
RV-13FR/13FRL, RV-20FR series	Three pcs.

- 5) Loosen the nut fixing tension adjustment screw <3>. Loosen the tension adjustment screw <3>, and remove the old belt.
- 6) Copy the marks onto the new timing belt. Make sure that both belts are tense when making the marks.
- 7) Align the new timing belt with the marks on the timing pulleys <4> and <5>, and install.
- 8) Turn tension adjustment screw <3>, and adjust the tension of timing belt <2>.

When the screw is turned to the right, the belt will be stretched, and when turned to the left, will loosen. Adjust the belt tension slack to within the range as shown in [Page 139, "\(15\) Timing belt tension"](#). Before the tension measurement, rotate the timing pulley at least three times in each direction so that the timing belt fits in the pulley. Check the tension measurement method in [Page 111, "\(2\) Timing belt tension measurement"](#).

If the belt is loosened too much when adjusting the tension causing it to come off the timing pulleys <4> and <5>, or if the belt and pulley teeth engagement is deviated, the machine system's origin will deviate.
- 9) After adjustment fastens the fixing nut of tension adjustment screw <3>, and certainly fixes tension adjustment screw <3>. Moreover, also fasten the motor plate fixing screws <1> certainly (M4 screw: tightening torque is 4.51 Nm). Improper tightening can cause the belt to loosen with vibration.
- 10) Install the No. 2 arm cover R securely as before.
- 11) Refer to [Page 155, "5.6 Resetting the origin"](#), and reset the origin position.
- 12) When the maintenance forecast function is valid, reset the accumulation data about the belt. Reset by the dedicated screen or parameter MFBRST of RT ToolBox3. Refer to "RT ToolBox3/RT ToolBox3 mini User's Manual" for operation of RT3 and refer to "Instruction Manual/Detailed Explanation of Functions and Operations" for the parameter.

(14) RV-4FR/7FR/13FR series: Inspection and replacement of J6-axis timing belt

The reference figure at inspection, adjustment, and replacement of the timing belt is shown in Fig. 5-25 (RV-4FR/7FR series, RV-7FRL) or Fig. 5-26 (RV-13FR/13FRL, RV-20FR series).

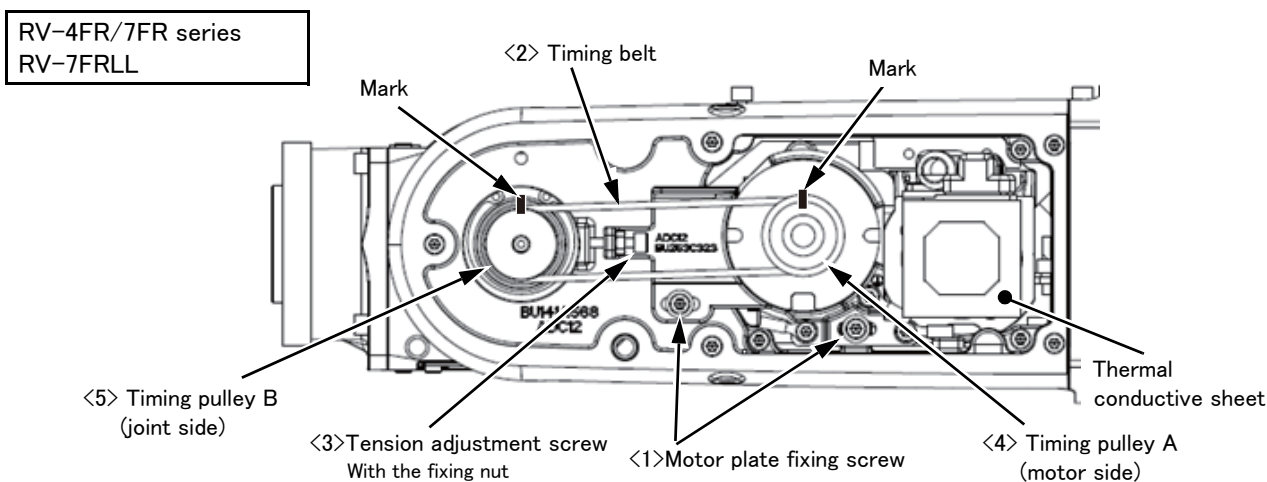

Fig.5-25 : Inspection and replacement of J6 axis timing belt (RV-4FR/7FR series, RV-7FRL)

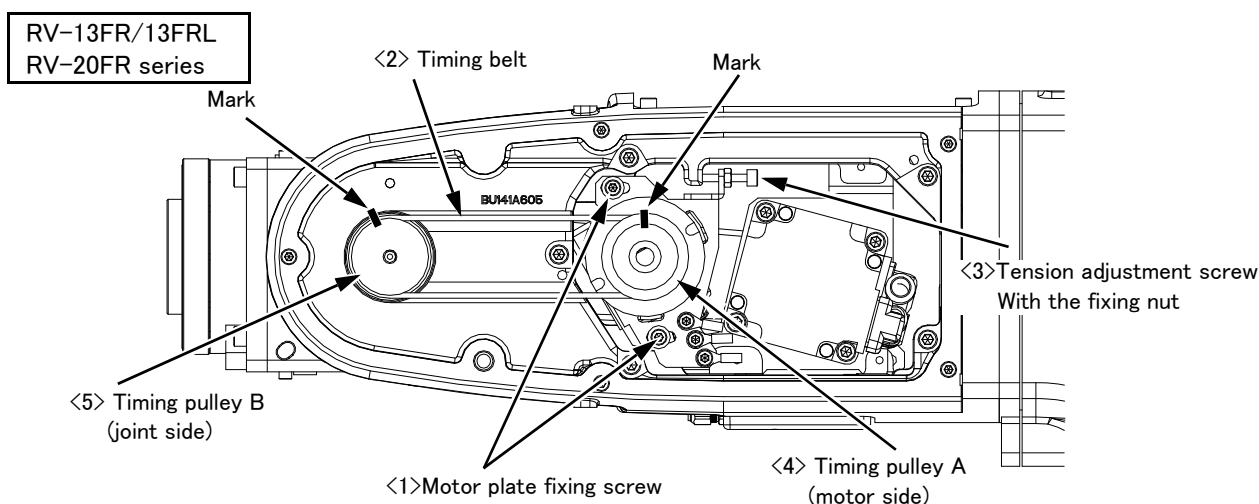

Fig.5-26 : Inspection and replacement of J6 axis timing belt (RV-13FR/13FRL, RV-20FR series)

■ Inspecting the J6 axis timing belt

- 1) Refer to Page 103, "5.3.2 Installing/removing the cover", and remove the No. 2 arm cover L.
- 2) Visually confirm that the symptoms indicated in "(1)Timing belt replacement period" have not occurred with the timing belt.
- 3) Refer to Page 111, "(2) Timing belt tension measurement", and confirm the belt tension.
- 4) Install the No. 2 arm cover L securely as before and finish inspection.

■ Replacing the J6 axis timing belt



CAUTION

It is possible for the customer to replace the timing belt, but precise adjustment is needed to prevent malfunction of the relevant parts. To ask for replacement of the timing belt, contact the dealer.

- 1) Refer to Page 103, "5.3.2 Installing/removing the cover", and remove the No. 2 arm cover L.
- 2) Make sure that the pulleys do not move while replacing the belt. If the pulley A <4> and B <5> position relation deviates, the position could deviate.
- 3) Make marks on the timing belt <2> and timing pulleys <4> and <5> with a felt-tip pen as shown in the figure above, so that the engagement of the timing belt <2> and timing pulleys <4> and <5> does not deviate.
- 4) Lightly loosen the two motor plate fixing screws <1>. (Do not loosen too much.)

- 5) Loosen the nut fixing tension adjustment screw <3>. Loosen the tension adjustment screw <3>, and remove the old belt.
- 6) Copy the marks onto the new timing belt. Make sure that both belts are tense when making the marks.
- 7) Align the new timing belt with the marks on the timing pulleys <4> and <5>, and install.
- 8) Turn tension adjustment screw <3>, and adjust the tension of timing belt <2>.

When the screw is turned to the right, the belt will be stretched, and when turned to the left, will loosen. Adjust the belt tension slack to within the range as shown in [Page 139, "\(15\) Timing belt tension"](#). Before the tension measurement, rotate the timing pulley at least three times in each direction so that the timing belt fits in the pulley. Check the tension measurement method in [Page 111, "\(2\) Timing belt tension measurement"](#).

If the belt is loosened too much when adjusting the tension causing it to come off the timing pulleys <4> and <5>, or if the belt and pulley teeth engagement is deviated, the machine system's origin will deviate.
- 9) After adjustment fastens the fixing nut of tension adjustment screw <3>, and certainly fixes tension adjustment screw <3>. Moreover, also fasten the two motor plate fixing screws <1> certainly (M4 screw: tightening torque is 4.51 Nm). Improper tightening can cause the belt to loosen with vibration.
- 10) Install the No. 2 arm cover L securely as before.
- 11) Refer to [Page 155, "5.6 Resetting the origin"](#), and reset the origin position.
- 12) When the maintenance forecast function is valid, reset the accumulation data about the belt. Reset by the dedicated screen or parameter MFBRST of RT ToolBox3. Refer to "RT ToolBox3/RT ToolBox3 mini User's Manual" for operation of RT3 and refer to "Instruction Manual/Detailed Explanation of Functions and Operations" for the parameter.

(15) Timing belt tension

The following table shows the preset values of the sonic belt tension gauge, the tension value for new belt installation, and the tension value as the replacement guideline.

Table 5-8 : Belt tension

Axis	Belt type	Preset value			Tension for new belt installation (N)	Replacement guideline tension (N)
		M(g/m)	W(mm/R)	S(mm)		
RV-2FR series						
J1	210-3GT-6	2.5	6	61	37 to 43	15
J2	324-3GT-6	2.5	6	88	37 to 43	15
J3	303-3GT-6	2.5	6	103	37 to 43	15
J4	186-3GT-4	2.5	4	52	26 to 30	10
J5	336-3GT-4	2.5	4	131	26 to 30	10
J5 (brake)	174-3GT-4	2.5	4	42	_Note1)	10
J6	345-3GT-4	2.5	4	131	26 to 30	10
J6 (brake)	174-3GT-4	2.5	4	42	_Note1)	10
RV-2FRL series						
J1	210-3GT-6	2.5	6	61	37 to 43	15
J2	324-3GT-6	2.5	6	88	37 to 43	15
J3	324-3GT-6	2.5	6	106	37 to 43	15
J4	186-3GT-4	2.5	4	52	26 to 30	10
J5	336-3GT-4	2.5	4	131	26 to 30	10
J5 (brake)	174-3GT-4	2.5	4	42	_Note1)	10
J6	345-3GT-4	2.5	4	131	26 to 30	10
J6 (brake)	174-3GT-4	2.5	4	42	_Note1)	10
RV-4FR series						
J1	315-EV3GT-12	2.5	12	85.5	79.7 to 97.4	30
J3	369-EV3GT-6	2.5	6	118.4	39.2 to 47.9	15
J4	240-EV3GT-6	2.5	6	56.4	39.2 to 47.9	15
J5	393-EV3GT-4	2.5	4	149.8	27.0 to 33.0	10
J6	270-EV3GT-4	2.5	4	96.0	27.0 to 33.0	10
RV-7FR series						
J1	405-EV5GT-20	4.0	20	107.5	96 to 118	70
J3	501-3GT-9	2.5	9	178.5	59.4 to 72.6	22
J4	237-EV3GT-6	2.5	6	54.9	39.2 to 47.9	15
J5	408-EV3GT-6	2.5	6	150.0	39.2 to 47.9	15
J6	270-EV3GT-4	2.5	4	96.0	27.0 to 33.0	10
RV-7FRL						
J4	252-EV3GT-9	2.5	9	60.0	59.4 to 72.6	22
J5	408-EV3GT-6	2.5	6	150.0	39.2 to 47.9	15
J6	270-EV3GT-4	2.5	4	96.0	27.0 to 33.0	10
RV-13FR/13FRL, RV-20FR series						
J4	252-EV3GT-9	2.5	9	60.0	59.4 to 72.6	22
J5	495-EV3GT-9	2.5	9	181.0	59.4 to 72.6	22
J6	330-EV3GT-6	2.5	6	111.0	39.2 to 47.9	15

Note1) The tension of the brake timing belt is automatically adjusted by work of spring installed on the motor plate.

(16) Amount of movement of each axis during the timing belt tension measurement

The amount of movement of each axis when the timing pulley A is rotated 90 degrees are shown in [Table 5-9](#).

Table 5-9 : Amount of movement of each axis during the tension measurement

Model	Amount of movement					
	J1 axis	J2 axis	J3 axis	J4 axis	J5 axis	J6 axis
RV-2FR series	0.8°	0.4°	0.8°	1.1°	1.1°	1.8°
RV-4FR series	1.1°	0.9°	0.6°	1.4°	1.6°	1.8°
RV-7FR	1.1°	1.1°	1.1°	0.8°	1.1°	1.8°
RV-7FRL	0.9°	0.9°	0.9°	0.8°	1.1°	1.8°
RV-7FRLL	-	-	-	1.9°	1.1°	1.8°
RV-13FR/13FRL	-	-	-	0.9°	0.9°	1.8°
RV-20FR series	-	-	-	0.6°	0.6°	1.8°

5.3.4 Lubrication

(1) RV-2FR series

■ Lubrication position and specifications

The grease nipple position is shown in Fig. 5-27. The lubrication specifications for each place are shown in Table 5-10. Refer to the Page 103, "5.3.2 Installing/removing the cover" for the method of removing and installing the cover.

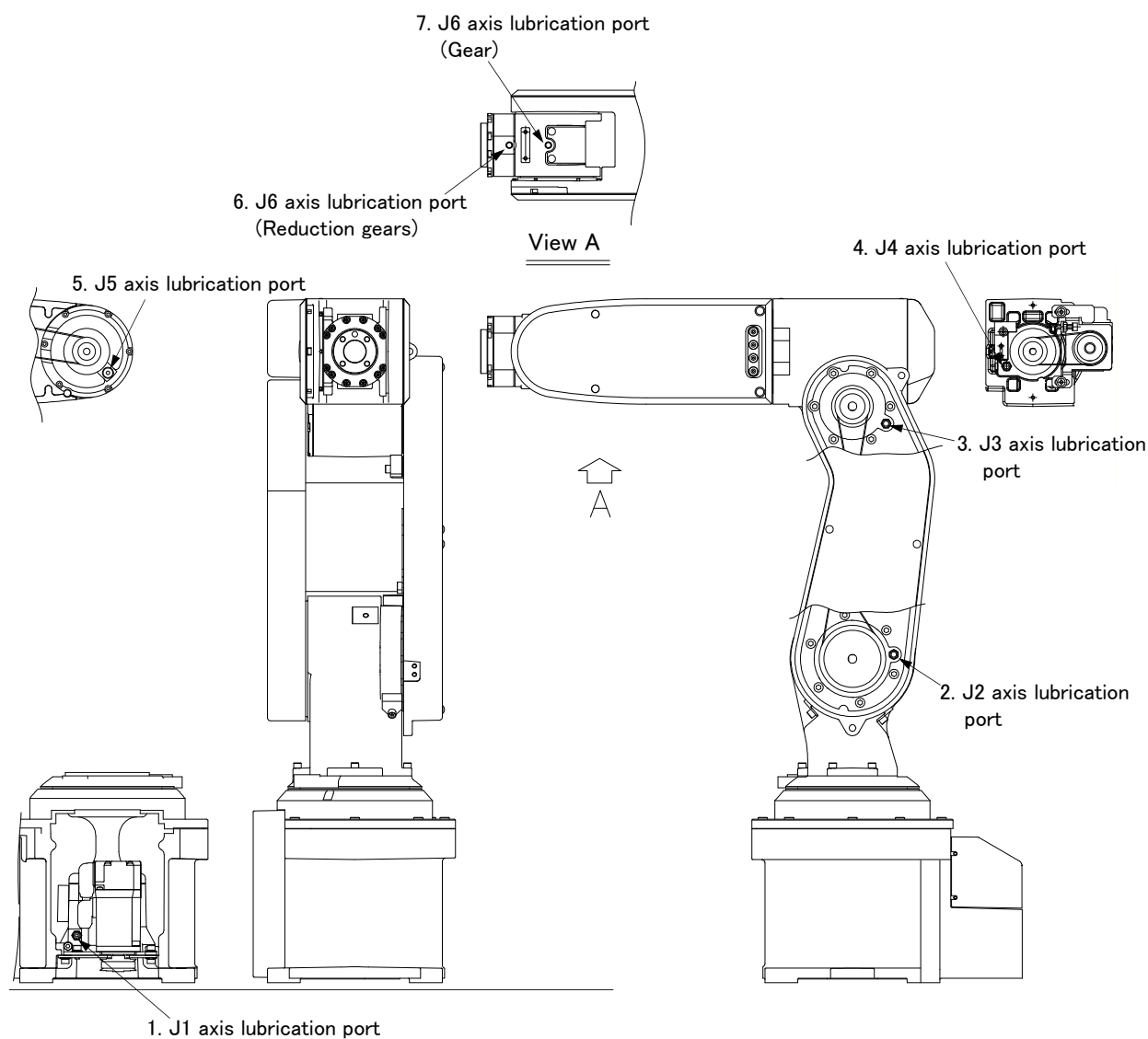

Fig.5-27 : Lubrication positions (RV-2FR series)

Table 5-10 : Lubrication specifications

No.	Parts to be lubricated	Oiling method	Lubrication oil (maker)	Lubrication interval	Lubrication amount	Cover to remove
1	J1 axis reduction gears	Grease nipple WA-610	Grease Harmonic grease SK-1A (Harmonic Drive Systems Inc.)	6,000Hr	3ml (2.8g)	J1 motor cover
2	J2 axis reduction gears				2.5ml (2.3g)	No1. Arm cover plate
3	J3 axis reduction gears				2.5ml (2.3g)	Elbow cover B
4	J4 axis reduction gears				0.5ml (0.5g)	—
5	J5 axis reduction gears				0.5ml (0.5g)	—
6	J6 axis reduction gears				0.5ml (0.5g)	—
7	J6 axis gear				1.4ml (1.3g)	—

[Caution]

- The brand name of the grease shown in the [Table 5-10](#) is the grease put in at shipping.
- The lubrication interval is a cumulative value of the operation at the maximum speed. If the operation has been suspended, or if the designated speed is slow, the lubrication time can be lengthened in proportion.
- Depending on the robot operation state, the lubrication interval will fluctuate, so determine the time according to the state so that the grease does not run out.
- The maintenance forecast function of RT ToolBox3 (option) estimates the lubrication interval depending on the operating conditions.
- The numbers in [Table 5-10](#) correspond to the supply positions in [Fig. 5-27](#).
- Because excessive lubrication leads to the grease leak, avoid it. And the number of times of lubrication limits to 3 times. The maintenance after it needs the overhaul work which replaces internal grease. Contact the dealer.

■ Lubrication method

- 1) Set the robot to the posture shown in [Fig. 5-27](#).
- 2) Refer to [Page 103](#), "5.3.2 Installing/removing the cover", and remove the covers.
- 3) Please protect the timing belt with the cloth etc. so that the grease does not take for the timing belt at the time of oil supply.
- 4) J5 axis lubrication port <5>, the J6 axis lubrication port <6> (reduction gears), and the J6 axis lubrication port <7> (gear) should remove the bolt, and should install the attached grease nipple. Securely tighten the grease nipple by 4.7 Nm to 6.3 Nm.
- 5) Insert the grease shown in [Table 5-10](#) using a grease gun from the lubrication grease nipple.
- 6) J5 axis lubrication port <5>, the J6 axis lubrication port <6> (reduction gears), and the J6 axis lubrication port <7> (gear) should remove the grease nipple, and should install the original bolt. Securely tighten the bolt by 4.7 Nm to 6.3 Nm.
- 7) Replace the covers with the removal procedure in reverse.
- 8) If the maintenance forecast function is enable, please reset the accumulated data about grease. Carries out the resetting operation by RT ToolBox3 (option) or parameter MFGRST. Refer to separate "RT ToolBox3/RT ToolBox3 mini User's Manual" for the operation method of RT ToolBox3, and refer to separate "Instruction Manual/Detailed Explanation of Functions and Operations" for details of parameter (MFGRST).

 **CAUTION**

Use manual grease gun, and inject grease with pressure 0.03Mpa or less. Do not use the grease gun, which derived by the factory air presser to avoid injecting by too high pressure.

A grease gun that fits the grease nipple is required.

Recommended grease gun: CH-400

(manufacture: Yamada Corporation Inc.,)

The CH-400 gun is a cartridge-type grease gun. Contact your dealer and use commercially available grease cartridges.

When a grease can is used, following hand grease gun is recommended.

Recommended grease gun: KH-120 (amount: 140ml)

(manufacture: Yamada Corporation Inc.,)

The KH-120 comes with a short nozzle (HSP-1) as standard. If this short nozzle does not reach the desired areas, depending on installation location, it may be useful to use a long nozzle (HSP-2). CH-400 has a long nozzle as standard equipment.

(2) RV-4FR/7FR/13FR series

■ Lubrication position and specifications

The grease nipple position is shown in Fig. 5-28 (RV-4FR/7FR series) or Fig. 5-29 (RV-13FR series). The lubrication specifications for each place are shown in Table 5-11. Refer to the Page 103, "5.3.2 Installing/removing the cover" for the method of removing and installing the cover.

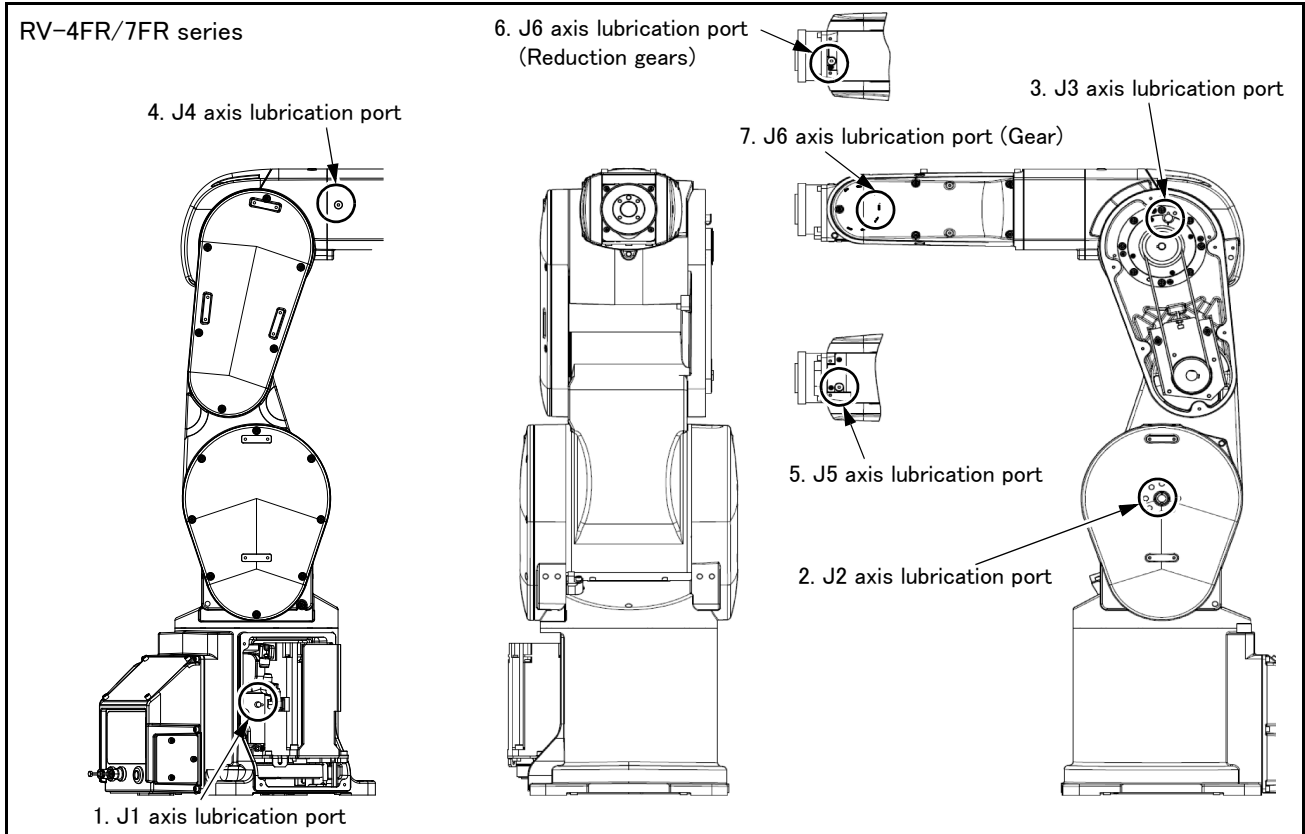

Fig.5-28 : Lubrication positions (RV-4FR/7FR series)

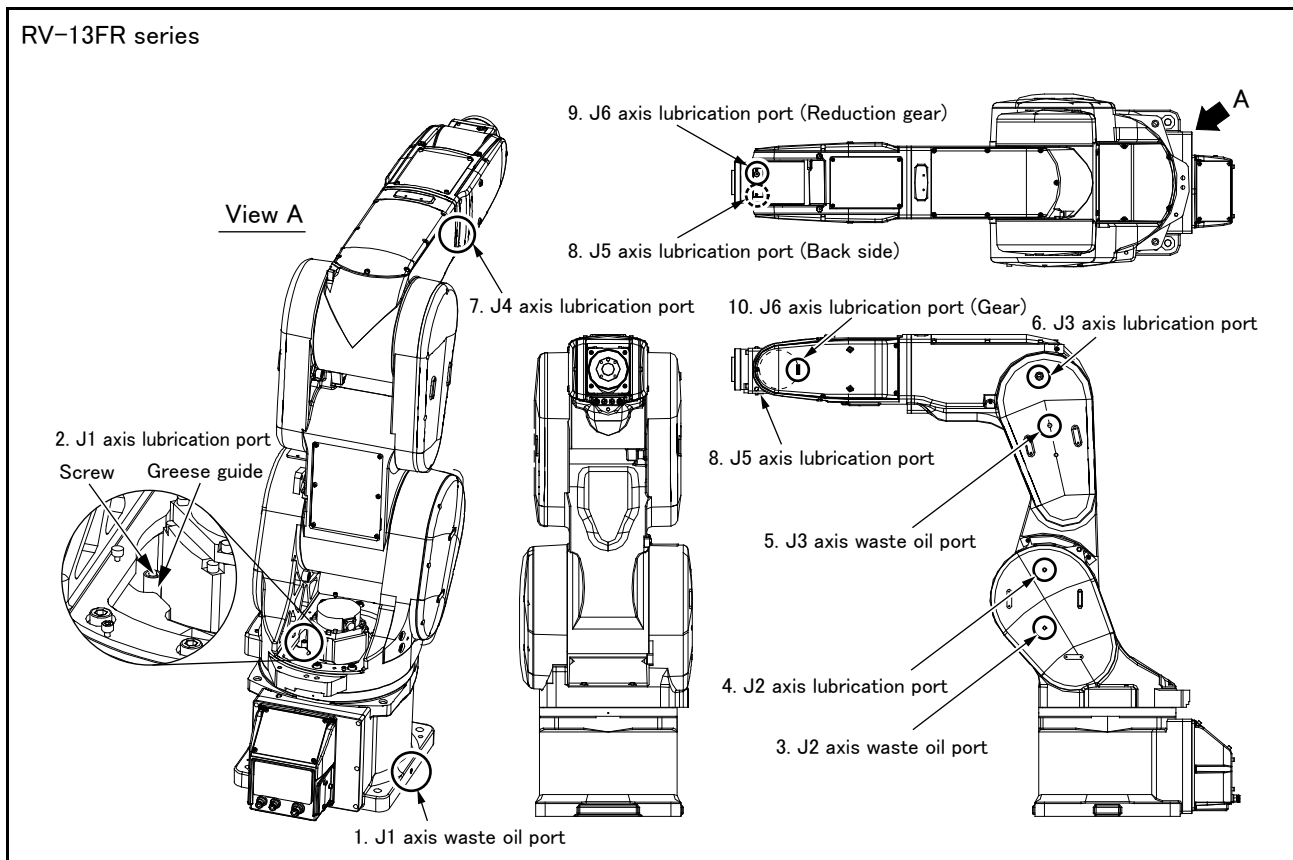

Fig.5-29 : Lubrication positions (RV-13FR series)

Table 5-11 : Lubrication specifications

No.	Parts to be lubricated ^{Note1)}	Oiling method	Lubrication oil (maker)	Lubrication interval	Lubrication amount	Cover to remove
RV-4FR series						
1	J1 axis reduction gears	Grease nipple WA-610	4B No.2 (Harmonic Drive Systems Inc.)	24,000Hr	8g	J1 motor cover
2	J2 axis reduction gears				8g	
3	J3 axis reduction gears				4g	No.1 arm cover L
4	J4 axis reduction gears				4g	
5	J5 axis reduction gears				2g	
6	J6 axis reduction gears				2g	
7	J6 axis gears				1.3g	Wrist cover
RV-7FR series						
1	J1 axis reduction gears	Grease nipple WA-610	4B No.2 (Harmonic Drive Systems Inc.)	24,000Hr	12g	J1 motor cover
2	J2 axis reduction gears				12g	
3	J3 axis reduction gears				8g	No.1 arm cover L
4	J4 axis reduction gears				4g	
5	J5 axis reduction gears				2g	
6	J6 axis reduction gears				2g	
7	J6 axis gears				1.3g	Wrist cover
RV-7FRLL						
1	J1 axis reduction gears	Grease nipple WA-110	VIGO GREASE (Nabtesco Co., Ltd.)	20,000Hr	255g	Shoulder cover
2	J2 axis reduction gears				251g	
3	J3 axis reduction gears				150g	

No.	Parts to be lubricated ^{Note1)}	Oiling method	Lubrication oil (maker)	Lubrication interval	Lubrication amount	Cover to remove
4	J4 axis reduction gears	Grease nipple WA-610	4B No.2 (Harmonic Drive Systems Inc.)	24,000Hr	7g	
5	J5 axis reduction gears				2g	
6	J6 axis reduction gears				2g	
7	J6 axis gears				1.3g	Wrist cover
RV-13FR/20FR						
1	J1 axis reduction gears	Grease nipple WA-110	VIGO GREASE (Nabtesco Co., Ltd.)	20,000Hr	255g	Shoulder cover
2	J2 axis reduction gears				251g	
3	J3 axis reduction gears				150g	
4	J4 axis reduction gears	Grease nipple WA-610	4B No.2 (Harmonic Drive Systems Inc.)	24,000Hr	7g	
5	J5 axis reduction gears				3g	
6	J6 axis reduction gears				2g	
7	J6 axis gears				1.5g	Wrist cover

Note1) When the screw is installed in the illustrated lubrication point, install the attached grease nipple and supply the grease.

[Caution]

- The brand name of the grease shown in [Table 5-11](#) is the grease put in at shipping.
- The lubrication interval is a cumulative value of the operation at the maximum speed. If the operation has been suspended, or if the designated speed is slow, the lubrication time can be lengthened in proportion.
- Depending on the robot operation state, the lubrication interval will fluctuate, so determine the time according to the state so that the grease does not run out.
- The maintenance forecast function of RT ToolBox3 (option) estimates the lubrication interval depending on the operating conditions.
- The numbers in [Table 5-11](#) correspond to the supply positions in [Fig. 5-28](#) (RV-4FR/7FR series) or [Fig. 5-29](#) (RV-13FR series).
- When the specified time limit (24,000 Hr) is due, the overhaul work to replace internal grease is required. If the overhaul cannot be conducted at the specified timing, lubricate them at the lubrication interval in [Table 5-11](#). For the overhaul, contact the dealer.
- When ceiling-mounted, the locations of the lubrication ports and waste oil ports on axes J1 to J3 of RV-13FR series robots are inverse.

■ Lubrication method

- 1) Set the robot to the posture shown in [Fig. 5-28](#) (RV-4FR/7FR series) or [Fig. 5-29](#) (RV-13FR series).
 - 2) Refer to the [Page 103](#), "5.3.2 Installing/removing the cover" and remove the covers.
 - 3) Please protect the timing belt with the cloth etc. so that the grease does not take for the timing belt at the time of oil supply.
 - 4) • RV-4FR series
Remove the following screws, and install the attached grease nipple.
J3 axis lubrication port <3>, J4 axis lubrication port <4>, J5 axis lubrication port <5>, J6 axis lubrication port (reduction gears) <6>, and J6 axis lubrication port (gear) <7> Securely tighten the grease nipple by 4.7 Nom to 6.3 Nom.
 - RV-7FR series
Remove the following screws, and install the attached grease nipples.
J4 axis lubrication port <4>, J5 axis lubrication port <5>, J6 axis lubrication port <6> (reduction gears) and J6 axis lubrication port <7> (gear). Securely tighten the grease nipple by 4.7 N·m to 6.3 N·m
 - RV-13FR series
Remove the screws from the J1 axis waste oil port <1>, the J2 axis waste oil port <3>, and the J3 axis waste oil port <5>. Wipe off the oil coming out of the screw holes with a rag or the like.
Remove the screw of from J1 axis lubrication port <2> to the J6 axis lubrication port (gear) <7>, and install the attached grease nipple. Securely tighten the grease nipple by 4.7 N·m to 6.3 N·m
- 5) Insert the grease shown in [Table 5-11](#) using a grease gun from the lubrication grease nipple.

- 6) For the RV-13FR series, wind thread sealing tape two or three times around the thread of the screws removed from waste oil ports <1>, <3>, and <5> (refer to the image below). Then tighten the screws from 7.1 N·m to 8.5 N·m

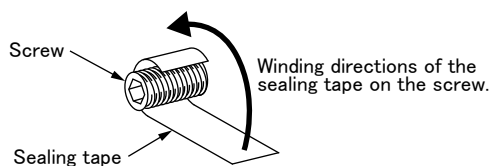

If the screw is tightened with lower/higher torque or not winded a sealing tape, it may cause grease to leak. (Recommended sealing tape: NITOFロン Pipe Seal No.95 (JIS), manufacture: NITTO DENKO)

- 7) Remove the grease nipples installed above and install the original screws.
- RV-4FR/7FR series
Tighten the screws by 4.7N·m – 6.3N·m.
 - RV-13FR series
In lubrication portion of from (7) to (10), tighten the screw by 4.7N·m – 6.3N·m.
In lubrication portion (2), (4), and (6), wind thread sealing tape two or three times around the thread of the screws (see 6)). (Recommended sealing tape: NITOFロン Pipe Seal No.95 (JIS), manufacture: NITTO DENKO)
Tighten the screw of lubrication portion (2) to the end surface of grease guide.
Tighten the screw of lubrication portion (4) and (6) by 7.1 N·m to 8.5 N·m.
If the screw is tightened with lower/higher torque or not winded a sealing tape, it may cause grease to leak.
- 8) Replace the covers with the removal procedure in reverse.
- 9) If the maintenance forecast function is enable, please reset the accumulated data about grease. Carries out the resetting operation by RT ToolBox3 (option) or parameter MFGRST. Refer to separate "RT ToolBox3/RT ToolBox3 mini User's Manual" for the operation method of RT ToolBox3, and refer to separate "Instruction Manual/Detailed Explanation of Functions and Operations" for details of parameter MFGRST.

CAUTION

Use manual grease gun, and inject grease with pressure 0.03Mpa or less. Do not use the grease gun, which derived by the factory air presser to avoid injecting by too high pressure.

A grease gun that fits the grease nipple is required.

Recommended grease gun: KH-120 (amount: 140ml) or KH-32 (amount: 200ml)
(manufacture: Yamada Corporation Inc.,)

The grease guns come with a short nozzle (HSP-1) as standard. If this short nozzle does not reach the desired areas, depending on the robot model and installation location, it may be useful to use a long nozzle (HSP-2).

5.3.5 Replacing the backup battery

An absolute encoder is used for the position detector, so while power of controller is turned off the position must be saved by the backup battery. The CR800-Q controller uses a backup battery to save the program, etc. These batteries are installed when the robot is shipped from the factory, but as these are consumable parts, they must be replaced periodically by the customer.

The guideline for replacing the battery is one year, but this will differ according to the robot's usage state. There exists the kinds of the errors about the battery shown in [Table 5-12](#). If error occurs, please exchange the battery of the robot arm and robot CPU unit (CR800-Q controller only).

Table 5-12 : The error about the battery

Error number	Description	Measure
7510	Encoder battery voltage low	Replace the battery as soon as possible.
7500	No encoder battery voltage	
112n ^{Note1)}	Encoder ABS position data lost	The backup data cannot be guaranteed if this error occurs.
7451 ^{Note2)}	Robot CPU unit battery voltage low	Replace the battery as soon as possible.
7450 ^{Note2)}	No robot CPU unit battery voltage	The backup data cannot be guaranteed if this error occurs.

Note1) "n" indicates the axis number

Note2) This error occurs in CR800-Q controller only.

The method of replacing the battery of robot arm is shown below.

Refer to the separate "Instruction manual/Controller setup, basic operation, and maintenance" about controller's battery.

About the purchase of the battery, refers to [Page 152, "5.5 Maintenance parts"](#).

CAUTION

If error 7500 or 112n (n indicates the axis number) occurs, the program data and other data in the controller is lost and it becomes necessary to load the data such as program and origin data again.

CAUTION

If error 7450 occurs, the program data and other data in the controller is lost and it becomes necessary to load the data such as program and origin data again.

(1) Replacing the battery of the robot arm

⚠ CAUTION

The battery circuit board connection cable is used to supply power from the backup battery to the encoder. The cable must be connected while replacing the battery or operating usually. Thus, if the cable connection is incomplete, the encoder position data will be lost, and resetting the origin is necessary.

⚠ CAUTION

Before replacing the backup battery, check that the capacitor is fully charged. If the robot has been used for over 36,000 hours, the battery life is gradually shortened due to deterioration of the capacitor.

⚠ CAUTION

Replace the battery one by one . If all batteries are removed the encoder data will be lost, and resetting the origin is necessary.

The battery installation position is shown below. Refers to the figure and replaces the batteries in the following procedures.

■ RV-2FR series

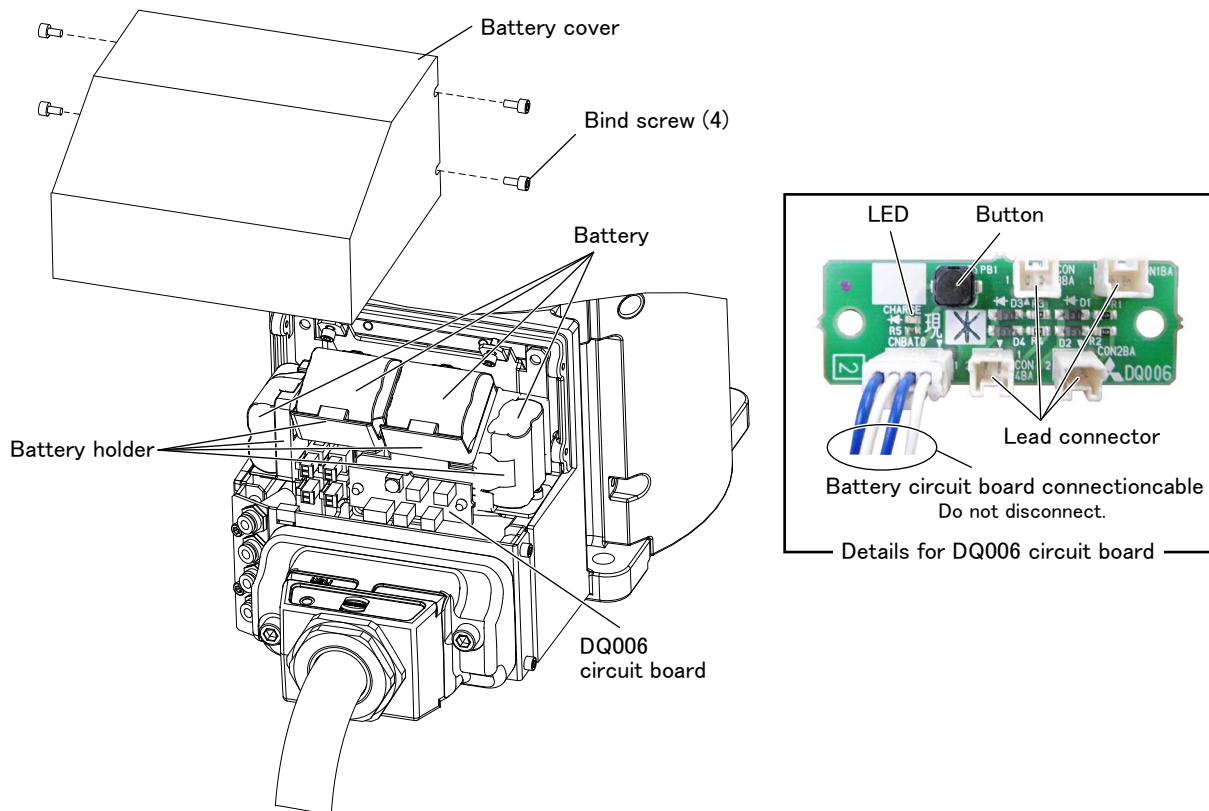

Fig.5-30 : Replacing the battery (RV-2FR series)

- 1) Turn the controller control power OFF.
- 2) Remove the battery cover, referring to [Page 103, "5.3.2 Installing/removing the cover"](#).
- 3) Check that the capacitor is fully charged. Press the button on the DQ006 circuit board and check that the LED on the same circuit board turns on.
Replace the battery within 15 minutes after checking that the LED turns on.
If the LED does not turn on when the button is pressed, the capacitor needs to be charged. Turn on the controller and charge the capacitor for approximately 30 minutes.
- 4) Replaces the backup battery one by one. The battery holder is located inside the battery cover. Remove the old battery from the holder, and disconnect the lead connector.
- 5) Insert the new battery into the holder, and connect the lead connector. Replace all batteries with new ones at the same time.

- 6) All the batteries should be checked that it has been exchanged newly. If the old battery is contained, generating heat and damaging may occur.
- 7) Install the battery cover as before. Be careful so that the cable may not be inserted.

[Caution] If the old battery is replaced because it has been used up, it is necessary to set the origin again.

Refer to [Page 155, "5.6 Resetting the origin"](#) and reset the origin using the ABS origin method.

The CR800-D controller requires time setup. Refer to the separate "Instruction Manual/Detailed Explanation of Functions and Operations" for details on the operation methods.

[Caution] When inserting and removing a lead connector of the backup battery, pay sufficient attention to the following points to prevent excessive force from being applied to the connector: Do not twist the connector during removal, and do not forcibly insert the connector when not mated properly.

■ RV-4FR/7FR/13FR series

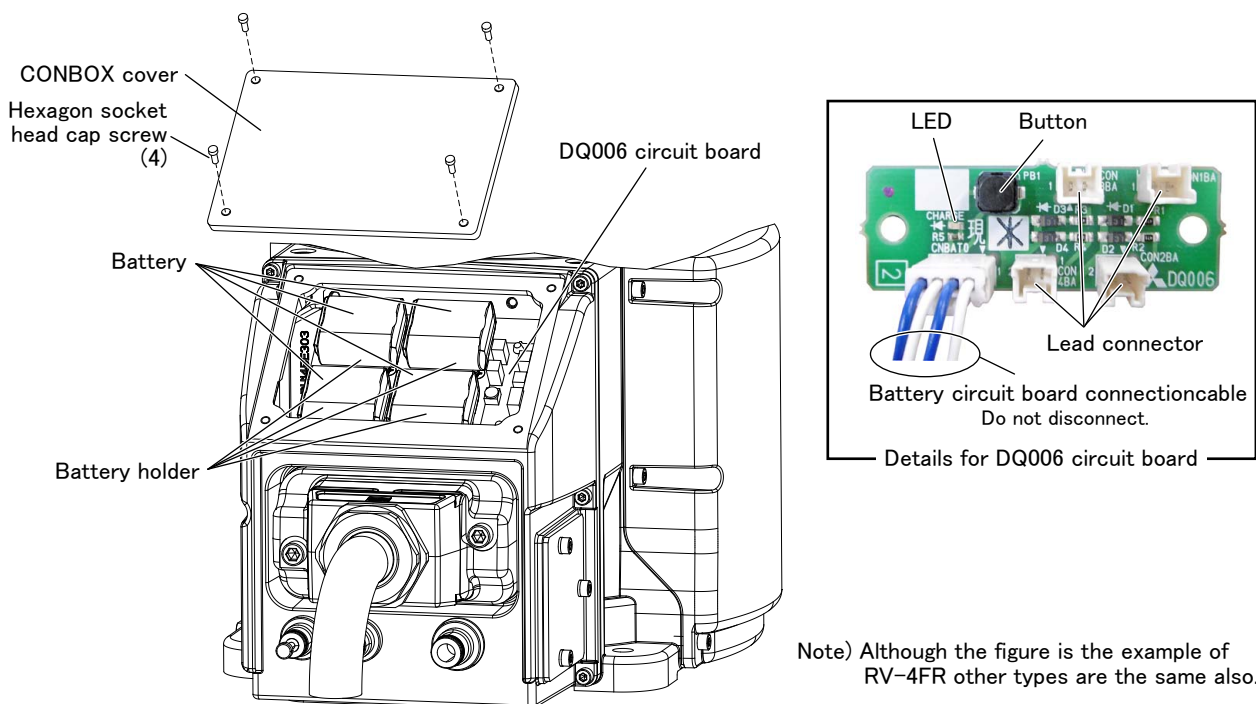

Fig.5-31 : Replacing the battery (RV-4FR/7FR/13FR series)

- 1) Turn the controller control power OFF.
- 2) Remove the CONBOX cover, referring to [Page 103, "5.3.2 Installing/removing the cover"](#).
- 3) Check that the capacitor is fully charged. Press the button on the DQ006 circuit board and check that the LED on the same circuit board turns on.
Replace the battery within 15 minutes after checking that the LED turns on.
If the LED does not turn on when the button is pressed, the capacitor needs to be charged. Turn on the controller and charge the capacitor for approximately 30 minutes.
- 4) Replaces the backup battery one by one. The battery holder is located inside the CONBOX cover. Remove the old battery from the holder, and disconnect the lead connector.
- 5) Insert the new battery into the holder, and connect the lead connector. Replace all batteries with new ones at the same time.
- 6) All the batteries should be checked that it has been exchanged newly. If the old battery is contained, generating heat and damaging may occur.
- 7) Install the CONBOX cover as before. Be careful so that the cable may not be inserted.

[Caution] If the old battery is replaced because it has been used up, it is necessary to set the origin again.

Refer to [Page 155, "5.6 Resetting the origin"](#) and reset the origin using the ABS origin method.

The CR800-D controller requires time setup. Refer to the separate "Instruction Manual/Detailed Explanation of Functions and Operations" for details on the operation methods.

[Caution] When inserting and removing a lead connector of the backup battery, pay sufficient attention to the following points to prevent excessive force from being applied to the connector: Do not twist the connector during removal, and do not forcibly insert the connector when not mated properly.

5.4 About Overhaul

Robots which have been in operation for an extended period of time can suffer from wear and other forms of deterioration. In regard to such robots, we define overhaul as an operation to replace parts running out of specified service life or other parts which have been damaged, so that the robots may be put back in shape for continued use. As a rule of thumb, it is recommended that overhaul be carried out before the total amount of servo-on time reaches the specified time (24,000 hours for the robot arm and 36,000 hours for the controller). (See Fig. 5-32.) However, the degree of the equipment's wear and deterioration presumably varies depending on their operating conditions. Especially for operation with high load and frequency, the maintenance cycle may be shorter. For details on the part selection for replacement and the timing of overhaul, contact your dealer.

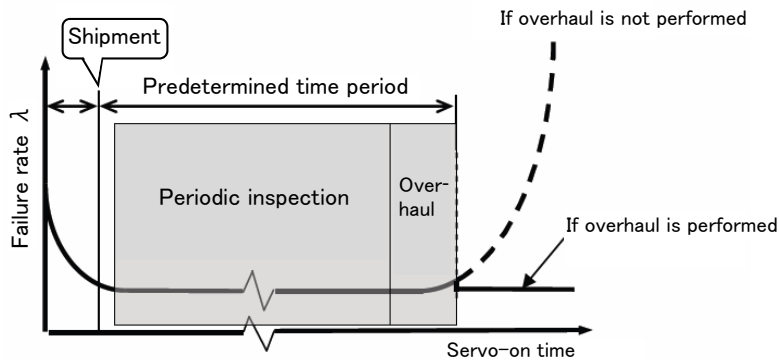

Fig.5-32 : Periodic inspection/overhaul periods

5.5 Maintenance parts

The consumable parts that must be replaced periodically are shown in [Table 5-13](#), and spare parts that may be required during repairs are shown in [Table 5-14](#). Purchase these parts from the dealer when required.

[Note] Some Mitsubishi-designated parts differ from the maker's standard parts. Thus, confirm the part name, robot arm and controller serial No. and purchase the parts from the dealer.

Table 5-13 : Consumable part list

No.	Part name	Usage place	Q'ty	Description	Supplier
RV-2FR series					
1	Timing belt	J1 axis	1	"5.3.3 Inspection replacement of timing belt"	Mitsubishi Electric
2		J2 axis	1		
3		J3 axis	1		
4		J4axis	1		
5		J5axis	1		
6		For J5 axis brakes	1		
7		J6 axis	1		
8		For J6 axis brakes ^{Note1)}	1		
9	Grease	Reduction gears of each axis	A small amount	"5.3.4 Lubrication"	
10	Lithium battery (MR-BAT6V1)	Base section	4	"5.3.5 Replacing the backup battery"	
RV-4FR/7FR series					
11	Timing belt	J1 axis	1	"5.3.3 Inspection replacement of timing belt"	Mitsubishi Electric
12		J3 axis	1		
13		J4 axis	1		
14		J5 axis	1		
15		J6 axis	1		
16	Grease	Reduction gears of each axis	A small amount	"5.3.4 Lubrication"	
17	Lithium battery (MR-BAT6V1)	Base section	4	"5.3.5 Replacing the backup battery"	
RV-13FR series					
18	Timing belt	J4 axis	1	"5.3.3 Inspection replacement of timing belt"	Mitsubishi Electric
19		J5 axis	1		
20		J6 axis	1		
21	Grease	Reduction gears of each axis	A small amount	"5.3.4 Lubrication"	
22	Lithium battery (MR-BAT6V1)	Base section	4	"5.3.5 Replacing the backup battery"	

Note1) Only for RV-2FRB.

Table 5-14 : Spare parts list

No.	Names	Usage place	Q'ty	Supplier
RV-2FR series (common)				
1	AC servo motor	J1,J2,J3 axis	3	Mitsubishi Electric
2		J4,J5,J6 axis	3	
RV-2FR/2FRB (Standard arm type)				
3	Reduction gears	J1 axis	1	Mitsubishi Electric
4		J2 axis	1	
5		J3 axis	1	
6		J4, J5 axis	2	
7		J6 axis	1	
RV-2FRL/2FRLB (Long arm type)				
8	Reduction gears	J1 axis	1	Mitsubishi Electric
9		J2 axis	1	
10		J3 axis	1	
11		J4, J5 axis	2	
12		J6 axis	1	

No.	Names	Usage place	Q'ty	Supplier
RV-4FR series (common)				
13	AC servo motor	J1, J2 axis	2	Mitsubishi Electric
14		J3 axis	1	
15		J4, J5 axis	2	
16		J6 axis	1	
RV-4FR (Standard arm type)				
17	Reduction gears	J1, J2 axis	2	Mitsubishi Electric
18		J3 axis	1	
19		J4 axis	1	
20		J5 axis	1	
21		J6 axis	1	
RV-4FRL (Long arm type)				
22	Reduction gears	J1 axis	1	Mitsubishi Electric
23		J2 axis	1	
24		J3 axis	1	
25		J4 axis	1	
26		J5 axis	1	
27		J6 axis	1	
RV-7FR series (common)				
28	AC servo motor	J1, J2 axis	2	Mitsubishi Electric
29		J3 axis	1	
30		J4, J5 axis	2	
31		J6 axis	1	
RV-7FR (Standard arm type)				
32	Reduction gears	J1, J2 axis	2	Mitsubishi Electric
33		J3 axis	1	
34		J4 axis	1	
35		J5 axis	1	
36		J6 axis	1	
RV-7FRL (Long arm type)				
37	Reduction gears	J1 axis	1	Mitsubishi Electric
38		J2, J3 axis	2	
39		J4 axis	1	
40		J5 axis	1	
41		J6 axis	1	
RV-7FRLL (Long arm type)				
42	AC servo motor	J1, J2 axis	2	Mitsubishi Electric
43		J3 axis	1	
44		J4 axis	1	
45		J5 axis	1	
46		J6 axis	1	
47		Reduction gears	J1 axis	
48	J2 axis		1	
49	J3 axis		1	
50	J4 axis		1	
51	J5 axis		1	
52	J6 axis		1	
RV-13FR/20FR (common)				
53	AC servo motor	J1, J2 axis	2	Mitsubishi Electric
54		J3 axis	1	
55		J4 axis	1	
56		J5 axis	1	
57		J6 axis	1	
RV-13FR/RV-20FR (Standard arm type)				
58	Reduction gears	J1 axis	1	Mitsubishi Electric
59		J2 axis	1	
60		J3 axis	1	
61		J4 axis	1	
62		J5 axis	1	
63		J6 axis	1	

No.	Names	Usage place	Q'ty	Supplier
RV-13FLR (Long arm type)				
64	Reduction gears	J1 axis	1	Mitsubishi Electric
65		J2 axis	1	
66		J3 axis	1	
67		J4 axis	1	
68		J5 axis	1	
69		J6 axis	1	

5.6 Resetting the origin

The origin is set so that the robot can be used with a high accuracy. The origin is set so that the robot can be used with a high accuracy. Setting is required if the motor is replaced or an encoder error occurs.

The origin setting methods and when each origin setting method is required are shown in [Table 5-15](#).

Table 5-15 : Origin setting method

No	Method	Explanation	Cases when setting the origin is required	Remarks
1	Origin data input method	The origin data set as the default is input from the T/B.	<ul style="list-style-type: none"> When the data is lost due to flat battery of the robot controller (when C7500 occurs) 	The setting method is explained in Page 156, "5.6.1 Setting the origin with the origin data input method" . If origin data has been changed from the factory default, input the latest origin data.
2	Jig method	The origin posture is set with the calibration jig installed.	<ul style="list-style-type: none"> When a structural part of the robot (motor, reduction gear, timing belt, etc.) is replaced When deviation occurred by a collision. 	The setting method is explained in Page 160, "5.6.2 Jig method" .
3	ABS origin method	This method is used when the encoder backup data lost in the cause such as battery cutting.	<ul style="list-style-type: none"> When the encoder data is lost due to flat battery of the robot arm (when H112n occurs) 	Before using this method, the origin must be set with the other method with same encoder. The setting method is explained in Page 180, "5.6.3 ABS origin method" .
4	User origin method	A randomly designated position is set as the origin posture.	<ul style="list-style-type: none"> When an arbitrary position is set as the origin 	Before using this method, the origin must be set with the other method. The setting method is explained in Page 185, "5.6.4 User origin method" .

[Caution]

- The origin is set using the jig method (No.2) at factory default.
- The origin data is inherent to the serial number of each robot arm.
- The ABS origin method is used to restore the previous data by aligning the triangular marks to each other for each axis to set the lost origin data.
(Although the setting position is confirmed visually, deviations within a half rotation of the motor can be compensated.)

[Remarks]

- The ABS origin method cannot be used when the robot arm mechanically deviates (for example caused by replacement of the reduction gear, motor, or timing belt).
- After the origin setting is completed, move the robot arm to the position where the ABS marks align each other, and check that the displayed joint coordinates of the position are correct.
For the details of the ABS mark position and the joint coordinates, refer to [Page 180, "5.6.3 ABS origin method"](#).

5.6.1 Setting the origin with the origin data input method

(1) Confirming the origin data

The origin data to be input is noted in the origin data sheet. (See Fig. 5-33.)

● Origin data history table (Origin Data History) Serial No.ES804008

Date	Default
D	V!#S29			
J1	06DTYY			
J2	2?HL9X			
J3	1CP55V			
J4	T6!M\$Y			
J5	Z2!J%Z			
J6	A12%Z0			
Method	J	J · A · U	J · A · U	J · A · U

(O: O(Alphabet), 0: Zero)

Note) Meanings of symbols in method column
 J: Jig method
 A: ABS origin method
 U: User origin method

Fig.5-33 : Origin data label (an example)

The origin data history table is attached on the back of the following covers.

Model	Cover
RV-2FR series	J1 motor cover
RV-4FR/7FR/13FR series	CONBOX cover

Referring to Page 103, "5.3.2 Installing/removing the cover", remove the cover above and confirm the value. The value given in the default setting column is the origin settings set with the jig method before shipment. Note that the 5-axis type robot does not have the J4 axis.

* The origin data to input is found on also the robot examination report sheet.

 **WARNING** Always install/remove the cover with the controller control power turned OFF. Failure to do so could lead to physical damage or personal injury should the robot start moving due to incorrect operations.

(2) Selecting the origin setting method

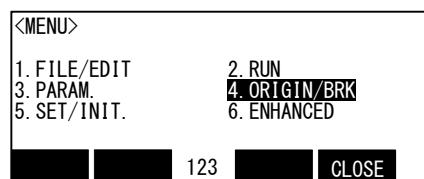

1) Press the [4] key on the menu screen, and display the ORIGIN/BRAKE screen.

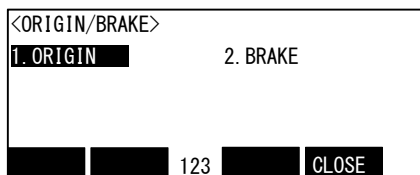

2) Press the [1] key on the ORIGIN/BRAKE screen, and display the origin setting method selection screen.

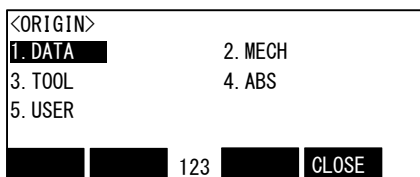
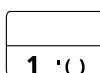

3) Press the [1] key on the origin setting method selection screen, and select the data input method.

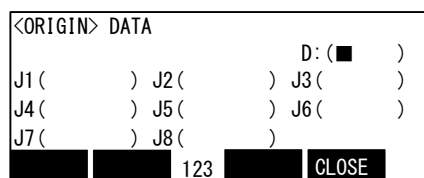
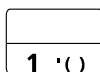

4) Display the origin data input screen

◆◆◆ Selecting a menu ◆◆◆

The menu can be selected with one of the following methods.

A: Press the numeral key for the No. of the item to be selected.

B: Using the [↓] and [↑] keys, etc., move the cursor to the item to be selected, and then press the [INP] key.

◆◆◆ The input method of numeral ◆◆◆

The number can be inputted if the key displayed on the lower left of each key is pressed. Press the

[CHARACTER] key, and in the condition that "123" is displayed on the screen lower side, press the number key.

(3) Inputting the origin data



Input the value confirmed in section Page 156, "(1) Confirming the origin data". The correspondence of the origin data label value and axis to be input is shown in Fig. 5-34. (For the 5-axis type robot, the J4 axis is meaningless.)

Fig.5-34 : Correspondence of origin data label and axis

The method for inputting the origin data is explained below. The value shown in Fig. 5-33 will be input as an example.

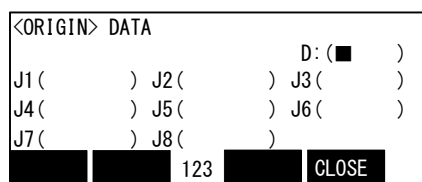

1) Confirm that the cursor is at the "D" position on the T/B display screen.

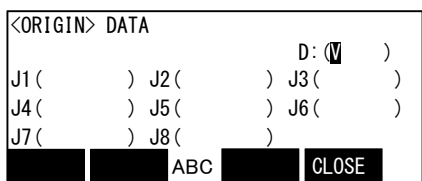

CHARACTER

-B (J5)
8 TUV

2) Input the D value "V!%S29".
Inputting "V"
Press the [CHARACTER] key and set to the character input mode. (Condition that "ABC" was displayed under the screen)
Press the [TUV] key three times. "V" will be set.

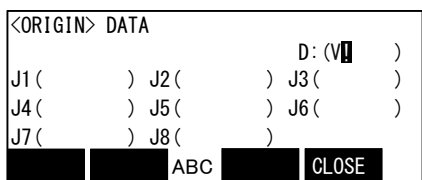

+C (J6)
. , %

→

+C (J6)
. , %

Inputting "!"
Press the [, %] key five times. "!" will be set.
Press the [→] key once and advance the cursor.
Press the [, %] key twice (input "%"), and press the [PQRS] key four times (input "S").

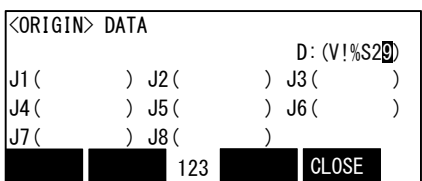

CHARACTER

-Z (J3)
2 ABC

+B (J5)
9 WXYZ

Press the [CHARACTER] key and set to the numeral input mode. (Condition that "123" was displayed under the screen)
Press the [2] key (input "2"), and press the [9] key (input "9").
"V!%S29" will appear at the "D" data on the teaching pendant screen.

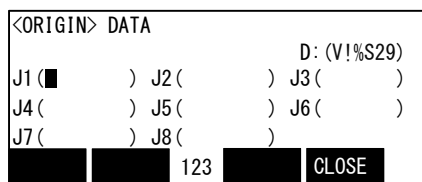

↓

3) Press the [↓] key, and move the cursor to the J1 input position.
4) Input the J1 value in the same manner as above.
5) Input the J2, J3, J4, J5 and J6 values in the same manner.
Note that the J4 axis is not required for the 5-axis type.

```

<ORIGIN> DATA
D: ( V!%S29)
J1 ( 06DTYY) J2 ( 2?HL9X) J3 ( 1CP55V)
J4 ( T6!MSY) J5 ( Z21J%Z) J6 ( A12%ZO)
J7 ( ) J8 ( )
ABC CLOSE

```

EXE

6) After inputting all of the values, press the [EXE] key. The origin setting confirmation screen will appear.

```

<ORIGIN> DATA
CHANGE TO ORIGIN. OK?
Yes 123 No

```

F1

7) Press [F1] (Yes) to end the origin setting

◆◆◆ Moving the cursor ◆◆◆

Press the [↑], [↓], [←] and [→] keys.

◆◆◆ Inputting characters ◆◆◆

Press the [CHARACTER] key and set to the character input mode. (Condition that "ABC" was displayed under the screen). The displayed character is scrolled each time at pressing the key.

◆◆◆ How to input symbols ◆◆◆

The symbol is allocated to ['()], [@=], and [,%] key. Please repress each key until the symbol to wish is displayed.

- ['()] key ' () " ^ ; ; ¥ ?
- [@=] key @ = + - * / < >
- [,%] key , % # \$! & _ .

◆◆◆ Correcting an input ◆◆◆

After returning one character by pressing the [CLEAR] key, input the character again.

(4) Installing the cover

Return the cover removed in section [Page 156, "\(1\) Confirming the origin data"](#) to its original position.



WARNING

Removing and installing the cover by always turning off the controller power.

Failure to do so could lead to the robot moving because of incorrect operations, or to physical damage or personal injury.

◆◆◆ If the origin input data is incorrect ◆◆◆

If the origin input data is incorrect, the alarm No. 1760 (origin setting data illegal) will occur when origin data input. In this case, reconfirm the value input for the origin data.

5.6.2 Jig method

This method is using the origin setting tool. If the origin setting tool is required, please ask nearby dealer. The reference figure of the origin setting tool is shown in Fig. 5-35.

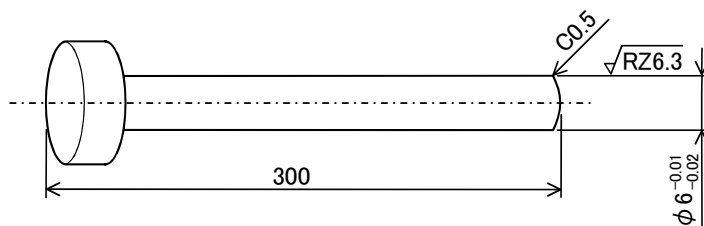

Fig.5-35 : Reference dimension of origin setting tool

The procedure of setting the origin with the origin setting tool is shown below.

When this method is used, origin setting is performed for each axis. First, set each axis to the origin position. There are two positioning methods: manual setting by releasing the brake and jog feeding. The following describes the positioning by releasing the brake. After the positioning, set the origin with the origin setting operation.

CAUTION

In the following procedure, the brake is released for the axis with brake to move the arm with both hands. When the brake is released, the arm may fall by its own weight depending on the posture of the robot. To ensure safety, take appropriate measures such as supporting the axis to avoid the free fall.

This operation is carried out with the teaching pendant. Set the mode of the controller to "MANUAL", and set the [ENABLE] switch on the teaching pendant to "ENABLE" to enable the teaching pendant. Do the following operations, pressing down the enabling switch of T/B lightly.

(1) J1 axis origin setting (jig)

<MENU>	
1. FILE/EDIT	2. RUN
3. PARAM.	4. ORIGIN/BRK
5. SET/INIT.	6. ENHANCED
REL.	123
CLOSE	
Select ORIGIN/BRK	
4 GHI	

1) Press the [4] key on the menu screen, and display the Origin/Brake selection screen.

<ORIGIN/BRAKE>	
1. ORIGIN	2. BRAKE
REL.	123
CLOSE	
Select BRAKE	
-Z (J3)	
2 ABC	

2) The type which does not have the brake in the J1 axis should go to "6"→"8". Press the [2] key, and display the Brake release selection screen.

<BRAKE>		
J1:(1)	J2:(0)	J3:(0)
J4:(0)	J5:(0)	J6:(0)
J7:(0)	J8:(0)	
REL.	123	CLOSE
select axis		
↑		
↓		
-C (J6)		
1 '()		
0 SPACE		

3) Release the brake of the J1 axis. Input "1" into the J1 axis. Set "0" to other axes.

<BRAKE>		
J1:(1)	J2:(0)	J3:(0)
J4:(0)	J5:(0)	J6:(0)
J7:(0)	J8:(0)	
REL.	123	CLOSE
Brake release		
F1		

4) Confirm the axis for which the brakes are to be released.
5) Pressing the [F1] key is kept with the enabling switch of T/B pressed down. The brake is released while pressing the key.

RV-2FR series

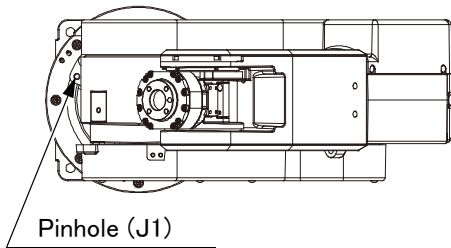

Diagram of the robot viewed from the top

6) Move the J1 axis slowly with both hands to the position around $\pm 0^\circ$. Align the pinhole of the lower part of the shoulder and the pinhole at the base section, feed through the origin jig ($\phi 6$) into the pinholes and fasten.

RV-4FR/7FR series

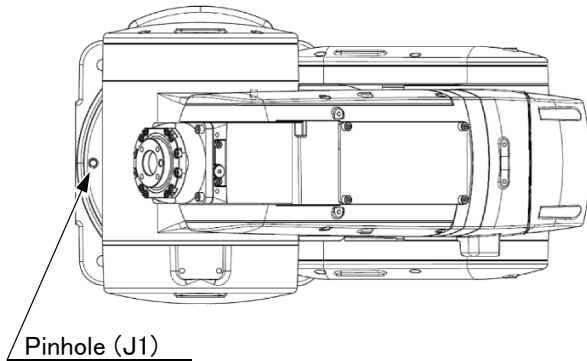

Diagram of the robot viewed from the top

RV-13FR series

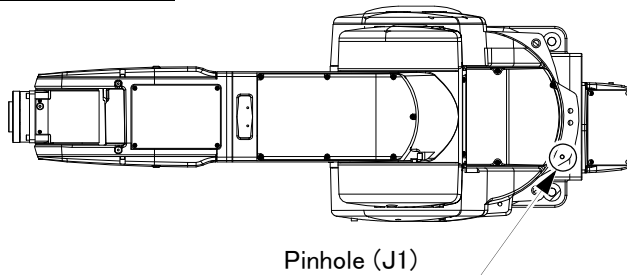
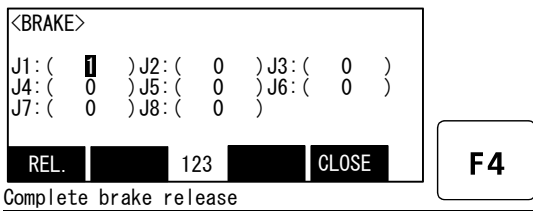
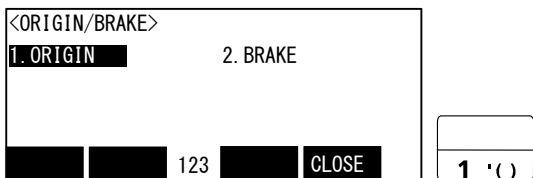

Diagram of the robot viewed from the top



7) Detach the [F1] key and work the brake. Press the [F4] key and return to the origin / brake screen.



8) Press the [1] key, and display the Origin setting selection screen.

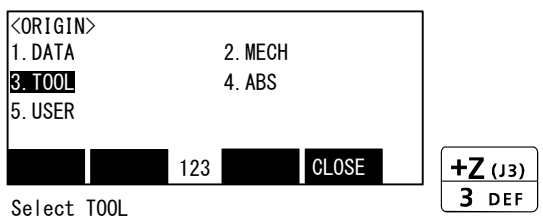

9) Press the [3] key, and display the Tool selection screen.

<TOOL>					
J1:	(1)	J2:	(0)
J4:	(0)	J5:	(0)
J7:	(0)	J8:	(0)
J3:	(0)	J6:	(0)
REL.		123	CLOSE		

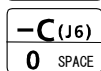
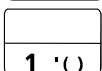

10) Input "1" into the J1 axis. Set "0" to other axes.

11) Press the [EXE] key, and display Confirmation screen.

<ORIGIN> TOOL	
CHANGE TO ORIGIN. OK?	
Yes	No
123	

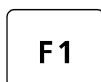

12) Press the [F1] key, and the origin position is set up.

<TOOL>						COMPLETED	
J1:	(1)	J2:	(0)	J3:	(0)
J4:	(0)	J5:	(0)	J6:	(0)
J7:	(0)	J8:	(0)		
REL.		123	CLOSE				

13) Setting of the origin is completed.

14) Refer to [Page 187](#), "5.6.5 Recording the origin data" in this manual, and record the origin data on the origin data seal.

◆◆◆ Release the brake ◆◆◆

Do cursor movement into the parenthesis of each axis by the arrow key. The brakes can be released only for the axis for which a "1" is displayed on the screen. If the brakes are not to be released, press the [0] key and display a "0". If the [F1] key on the teaching pendant or the enabling switch is detached while the brakes are released, the brakes will be work immediately.

◆◆◆ Select the axis of origin setting ◆◆◆

Do cursor movement into the parenthesis of each axis by the arrow key. The origin is set only for the axis for which a "1" is displayed on the screen. If the origin is not to be set, press the [0] key and display a "0".

(2) J2 axis origin setting (jig)

<MENU>	
1. FILE/EDIT	2. RUN
3. PARAM.	4. ORIGIN/BRK
5. SET/INIT.	6. ENHANCED
REL.	123 CLOSE

4 GHI

1) Press the [4] key on the menu screen, and display the Origin/Brake selection screen.

<ORIGIN/BRAKE>	
1. ORIGIN	2. BRAKE
REL.	123 CLOSE

-Z (J3)
2 ABC

2) Press the [2] key, and display the Brake release selection screen.

<BRAKE>		
J1: (0)	J2: (1)	J3: (0)
J4: (0)	J5: (0)	J6: (0)
J7: (0)	J8: (0)	
REL.	123 CLOSE	

↑ ↓

1 ' () -C (J6)
0 SPACE

3) Release the brake of the J2 axis. Input "1" into the J2 axis. Set "0" to other axes.

<BRAKE>		
J1: (0)	J2: (1)	J3: (0)
J4: (0)	J5: (0)	J6: (0)
J7: (0)	J8: (0)	
REL.	123 CLOSE	

F1

4) Confirm the axis for which the brakes are to be released.

5) One worker must securely support the upper arm with both hands.

6) Pressing the [F1] key is kept with the enabling switch of T/B pressed down. The brake is released while pressing the key.

Note) In the RV-13FR series, brake is released in an off-and-on way, because to drop J2 axis slowly.

<RV-2FR series>

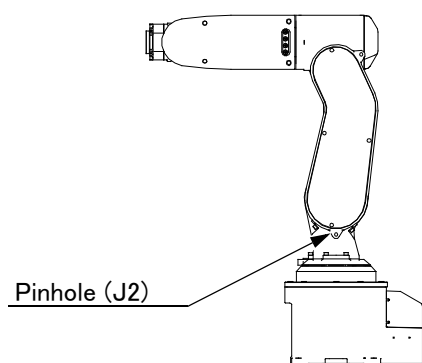

<RV-4FR series>

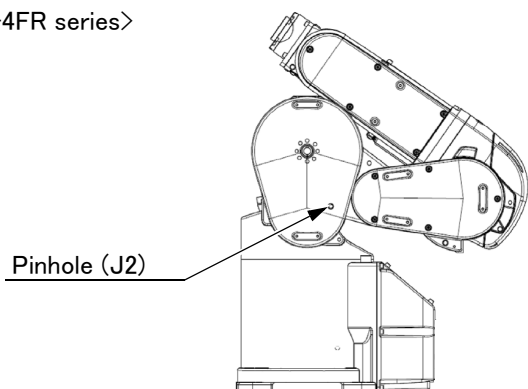

<RV-7FR series>

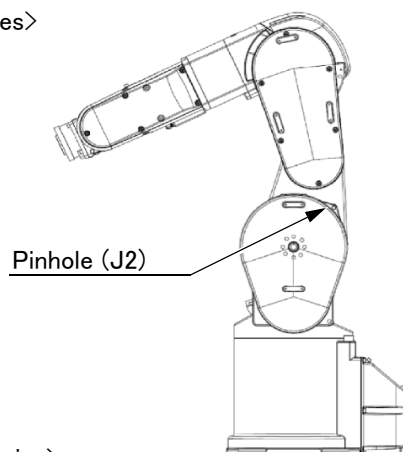

<RV-13FR series>

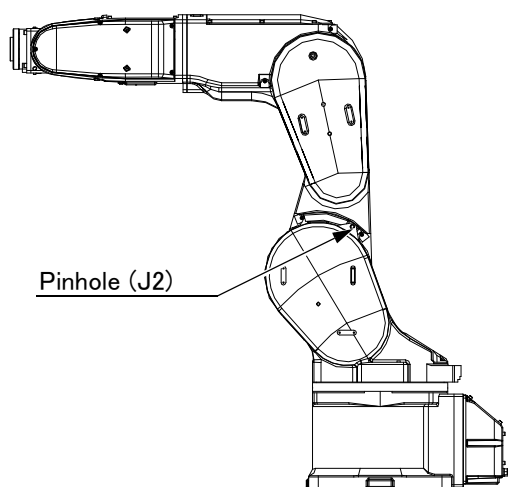

- 7) Move the J2 axis slowly with both hands to the following position and align the pinhole of the No.1 arm and the pinhole at the shoulder.

Robot model	Position
RV-2FR series	Around $\pm 0^\circ$
RV-4FR series	Around -107°
RV-7FR/13FR series	Around $\pm 0^\circ$

Feed through the J2 axis origin jig ($\phi 6$) into the aligned pinholes and fasten.

For safety purposes, the step for releasing the brakes must be carried out by two workers. One worker must operate the T/B, and the other must support the arm.

When the brakes are released, the robot arm could drop by its own weight depending on the posture.



CAUTION

When the brake is released, the arm may fall by its own weight depending on the posture of the robot.

To ensure safety, take appropriate measures such as supporting the axis to avoid the free fall.



CAUTION

If [F1] key or enable switch of T/B is released, the brakes will be work immediately.

```

<BRAKE>
J1: ( 0 ) J2: ( 1 ) J3: ( 0 )
J4: ( 0 ) J5: ( 0 ) J6: ( 0 )
J7: ( 0 ) J8: ( 0 )
REL. 123 CLOSE

```

F4

- 8) Detach the [F1] key and work the brake.
Press the [F4] key and return to the origin / brake screen.

```

<ORIGIN/BRAKE>
1. ORIGIN 2. BRAKE
123 CLOSE

```

1 '()

- 9) Press the [1] key, and display the Origin setting selection screen.

```

<ORIGIN>
1. DATA 2. MECH
3. TOOL 4. ABS
5. USER
123 CLOSE

```

+Z (J3)
3 DEF

- 10) Press the [3] key, and display the Tool selection screen.

```

<ORIGIN> TOOL
J1: (0) J2: (1) J3: (0)
J4: (0) J5: (0) J6: (0)
J7: (0) J8: (0)
123 CLOSE

```

↑

↓

1 '()

-C (J6)
0 SPACE

EXE

- 11) Input "1" into the J2 axis. Set "0" to other axes.

- 12) Press the [EXE] key, and display Confirmation screen.

```

<ORIGIN> TOOL
CHANGE TO ORIGIN. OK?
Yes 123 No

```

F1

- 13) Press the [F1] key, and the origin position is set up.

```

<ORIGIN> TOOL COMPLETED
J1: (0) J2: (1) J3: (0)
J4: (0) J5: (0) J6: (0)
J7: (0) J8: (0)
123 CLOSE

```

- 14) Setting of the origin is completed.

- 15) Refer to [Page 187](#), "5.6.5 Recording the origin data" in this manual, and record the origin data on the origin data seal.

◆◆◆ Release the brake ◆◆◆

Do cursor movement into the parenthesis of each axis by the arrow key. The brakes can be released only for the axis for which a "1" is displayed on the screen. If the brakes are not to be released, press the [0] key and display a "0". If the [F1] key on the teaching pendant or the enabling switch is detached while the brakes are released, the brakes will be work immediately.

◆◆◆ Select the axis of origin setting ◆◆◆

Do cursor movement into the parenthesis of each axis by the arrow key. The origin is set only for the axis for which a "1" is displayed on the screen. If the origin is not to be set, press the [0] key and display a "0".

(3) J3 axis origin setting (jig)

<MENU>	
1. FILE/EDIT	2. RUN
3. PARAM.	4. ORIGIN/BRK
5. SET/INIT.	6. ENHANCED
123	CLOSE

4 GHI

1) Press the [4] key on the menu screen, and display the Origin/Brake selection screen.

<ORIGIN/BRAKE>	
1. ORIGIN	2. BRAKE
123	CLOSE

-Z (J3)
2 ABC

2) Press the [2] key, and display the Brake release selection screen.

<BRAKE>			↑	↓
J1: (0)	J2: (0)	J3: (1)		
J4: (0)	J5: (0)	J6: (0)		
J7: (0)	J8: (0)			
REL.	123	CLOSE	1 '()	-C (J6) 0 SPACE

3) Release the brake of the J3 axis.

Input "1" into the J3 axis. Set "0" to other axes.

4) Confirm the axis for which the brakes are to be released.

5) One worker must securely support the upper arm with both hands.

<BRAKE>			
J1: (0)	J2: (0)	J3: (1)	
J4: (0)	J5: (0)	J6: (0)	
J7: (0)	J8: (0)		
REL.	123	CLOSE	F1

6) Pressing the [F1] key is kept with the enabling switch of T/B pressed down. The brake is released while pressing the key.

Note) In the RV-13FR series, brake is released in an off-and-on way, because to drop J2 axis slowly.

<RV-2FR series>

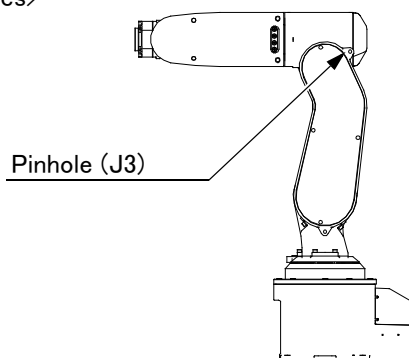

- 7) Move the J3 axis slowly with both hands to the following position and align the pinhole of the No.1 arm and the pinhole at the elbow.

Robot model	Position
RV-2FR/4FR series	Around +90°
RV-7FR series	Around +115°
RV-13FR series	Around +90°

Feed through the J3 axis origin jig ($\phi 6$) into the aligned pinholes and fasten.

<RV-4FR series>

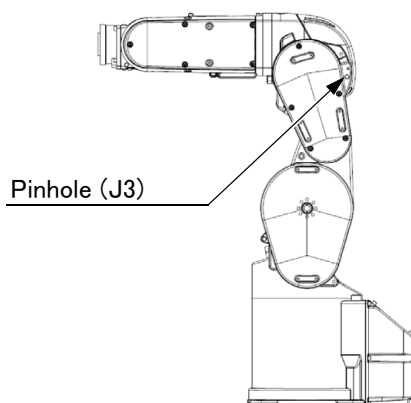

<RV-7FR series>

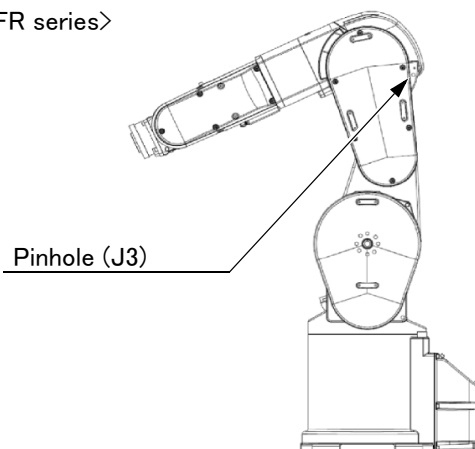

<RV-13FR series>

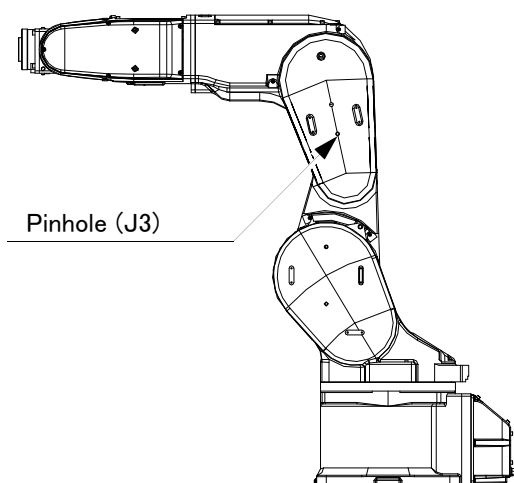

CAUTION

When the brake is released, the arm may fall by its own weight depending on the posture of the robot. To ensure safety, take appropriate measures such as supporting the axis to avoid the free fall.

CAUTION

If [F1] key or enable switch of T/B is released, the brakes will be work immediately.

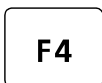
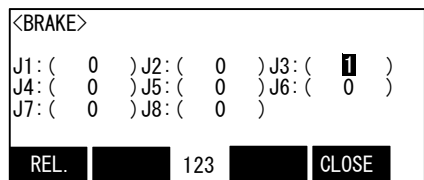

8) Detach the [F1] key and work the brake. Press the [F4] key and return to the origin / brake screen.

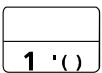
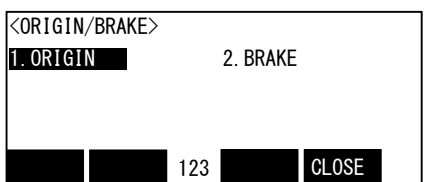

9) Press the [1] key, and display the Origin setting selection screen.

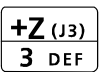
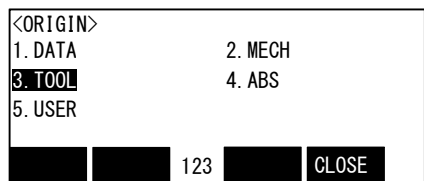

10) Press the [3] key, and display the Tool selection screen.

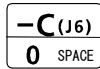
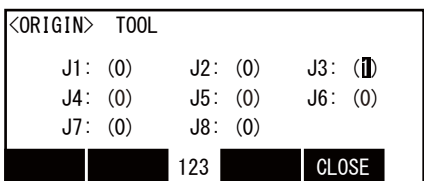

11) Input "1" into the J3 axis. Set "0" to other axes. 12) Press the [EXE] key, and display Confirmation screen.

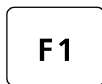
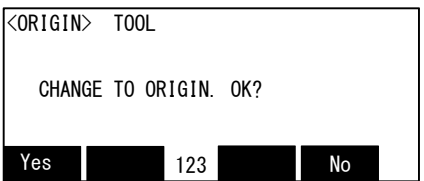

13) Press the [F1] key, and the origin position is set up.

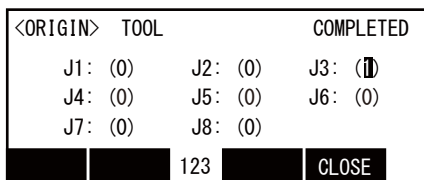

14) Setting of the origin is completed.

15) Refer to [Page 187](#), "5.6.5 Recording the origin data" in this manual, and record the origin data on the origin data seal.

◆◆◆ Release the brake ◆◆◆

Do cursor movement into the parenthesis of each axis by the arrow key. The brakes can be released only for the axis for which a "1" is displayed on the screen. If the brakes are not to be released, press the [0] key and display a "0". If the [F1] key on the teaching pendant or the enabling switch is detached while the brakes are released, the brakes will be work immediately.

◆◆◆ Select the axis of origin setting ◆◆◆

Do cursor movement into the parenthesis of each axis by the arrow key. The origin is set only for the axis for which a "1" is displayed on the screen. If the origin is not to be set, press the [0] key and display a "0".

(4) J4 axis origin setting (6-axis type robot only)

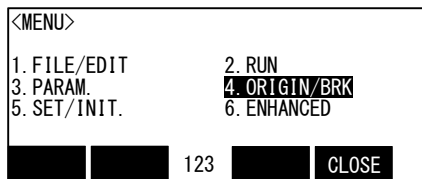

1) Press the [4] key on the menu screen, and display the Origin/Brake selection screen.

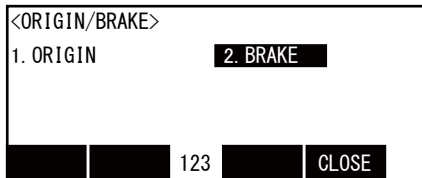

2) The type which does not have the brake in the J4 axis should go to "7" -> "9". Press the [2] key, and display the Brake release selection screen.

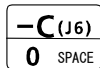
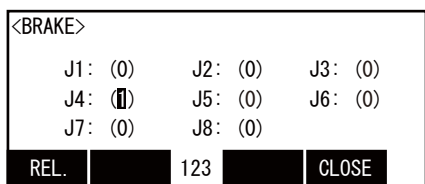

3) Release the brake of the J4 axis. Input "1" into the J4 axis. Set "0" to other axes.

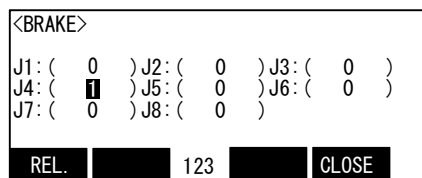

4) Confirm the axis for which the brakes are to be released.

5) One worker must securely support the upper arm with both hands.

6) Pressing the [F1] key is kept with the enabling switch of T/B pressed down. The brake is released while pressing the key.

<RV-2FR series>

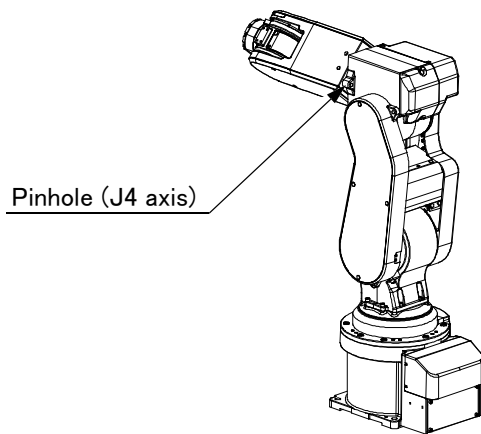

7) Move the J4 axis slowly with both hands to the following position and align the pinhole of the No.2 arm and the pinhole at the elbow.

Robot model	Position
RV-2FR series	Around -50°
RV-4FR/7FR/13FR series	Around $\pm 0^{\circ}$

Feed through the J4 axis origin jig ($\phi 6$) into the aligned pinholes and fasten.

<RV-4FR/7FR/13FR series>

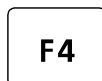
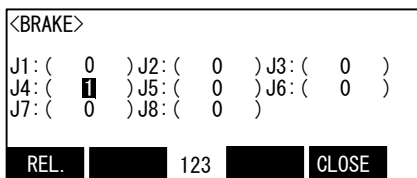
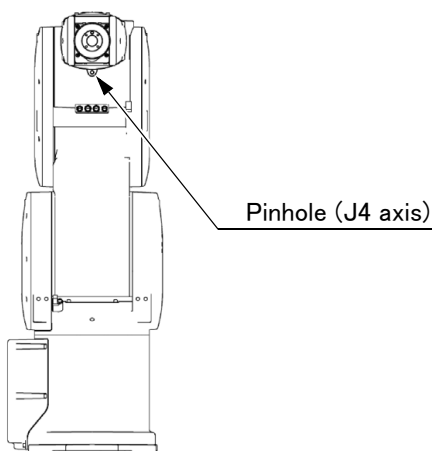

8) Detach the [F1] key and work the brake. Press the [F4] key and return to the origin / brake screen.

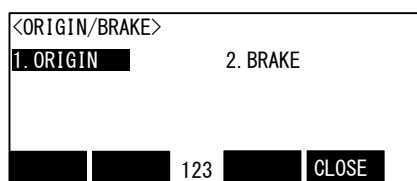

9) Press the [1] key, and display the Origin setting selection screen.

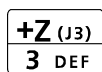
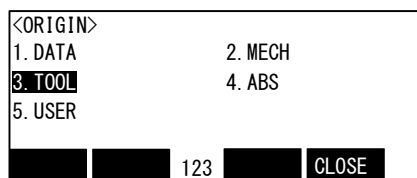

10) Press the [3] key, and display the Tool selection screen.

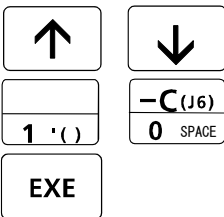
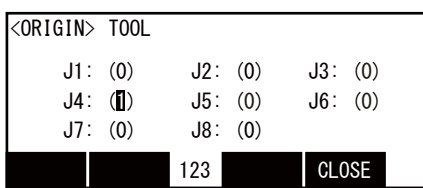

- 11) Input "1" into the J4 axis. Set "0" to other axes.
- 12) Press the [EXE] key, and display Confirmation screen.

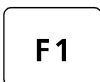
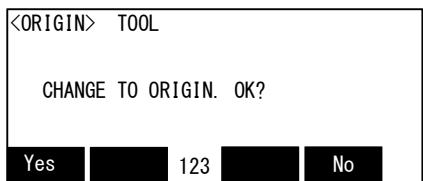

- 13) Press the [F1] key, and the origin position is set up.

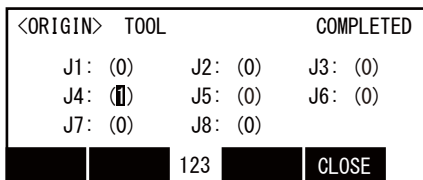

- 14) Setting of the origin is completed.
- 15) Refer to [Page 187](#), "5.6.5 Recording the origin data" in this manual, and record the origin data on the origin data seal.

◆◆◆ Release the brake ◆◆◆

Do cursor movement into the parenthesis of each axis by the arrow key. The brakes can be released only for the axis for which a "1" is displayed on the screen. If the brakes are not to be released, press the [0] key and display a "0". If the [F1] key on the teaching pendant or the enabling switch is detached while the brakes are released, the brakes will be work immediately.

◆◆◆ Select the axis of origin setting ◆◆◆

Do cursor movement into the parenthesis of each axis by the arrow key. The origin is set only for the axis for which a "1" is displayed on the screen. If the origin is not to be set, press the [0] key and display a "0".

(5) Origin setting of J5 axis and J6 axis (jig)

Always perform origin setting of the J5 axis and the J6 axis simultaneously. First, set the J5 axis posture.

1) Remove the following cover. The pin hole is inside the cover.

Robot model	Cover
RV-2FR series	No.2 arm cover R
RV-4FR/7FR/13FR series	No.2 arm cover L

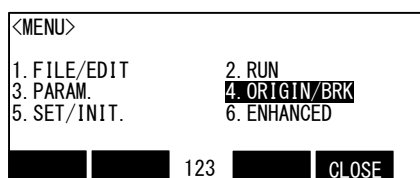

2) Press the [4] key on the menu screen, and display the Origin/BRK selection screen.

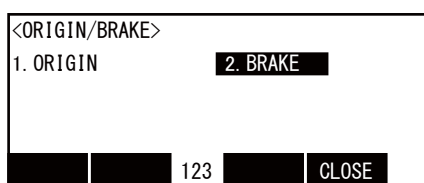

3) Press the [2] key, and display the Brake release selection screen.

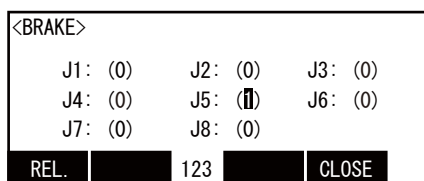

4) Brake release of the J5 axis

Press the [Arrow] key, move the cursor to the J5 axis and press the [1] key. Set [0] to other axes.

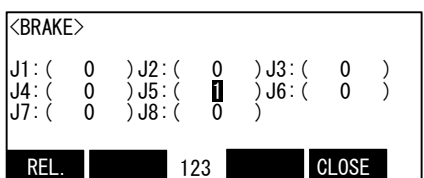

5) Confirm the axis for which the brakes are to be released.

6) The one person needs to support the list part securely with both hands.

7) Pressing the [F1] key is kept with the enabling switch of T/B pressed down. The brake is released while pressing the key.

<RV-2FR series>

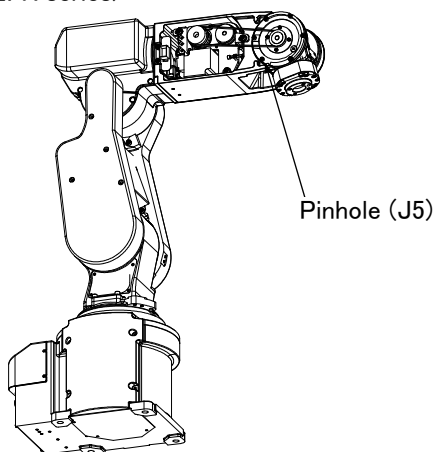

8) Move the J5 axis slowly with both hands to the following position and align the pinhole of the No.2 arm and the pinhole at the wrist.

Robot model	Position
RV-2FR series	Around +75°
RV-4FR/7FR/13FR series	Around +90°

Feed through the J5 axis origin jig ($\phi 6$) into the aligned pinholes and fasten.

<RV-4FR/7FR/13FR series>

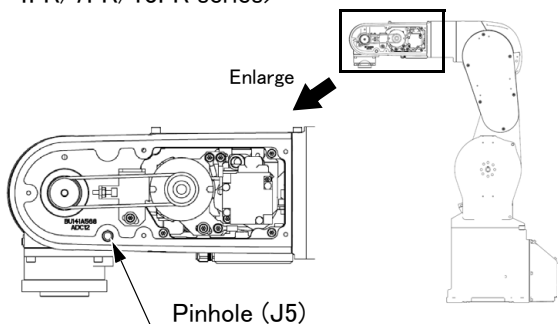

CAUTION

When the brake is released, the arm may fall by its own weight depending on the posture of the robot. To ensure safety, take appropriate measures such as supporting the axis to avoid the free fall.

CAUTION

If the [F1] key or the enabling switch of T/B is detached, the brake will work immediately.

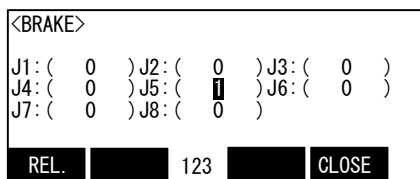

9) Detach the [F1] key and work the brake.

Next, set the J6 axis posture.

<RV-2FR series>

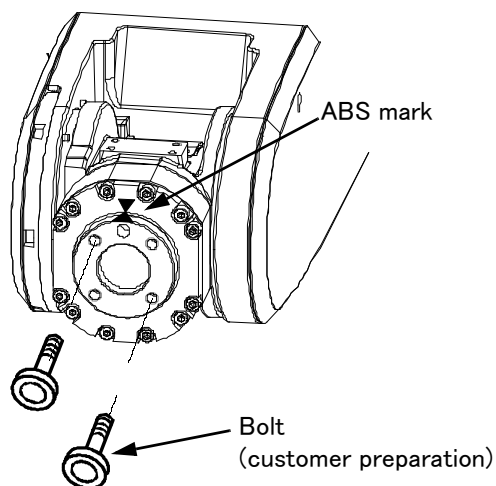

- 10) Install the following bolt (customer preparation) in the diagonal position at the J6 axis.

Robot model	Bolt
RV-2FR/4FR/7FR series	M5, 2 pcs.
RV-13FR series	M6, 2 pcs.

Hold the bolts with hands, rotate them slowly and align the ABS mark of the J6 axis with the ABS mark of the wrist area.

The type which has the brake in the J6 axis releases the brake. The type which does not have the brake should go to "15".

[Press the [Arrow] key, move the cursor to the J6 axis and press the [1] key. Set [0] to other axes.

CAUTION The J6-axis does not have a mechanical stopper. When setting the origin position do not rotate the axis more than the motion range (± 200 deg.).

<RV-4FR/7FR/13FR series>

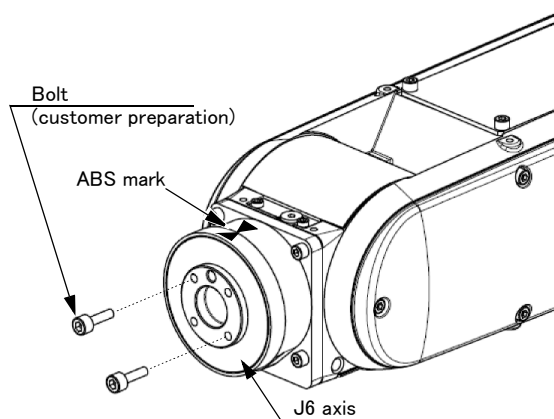

CAUTION The J6 axis of internal wiring and piping specification type have mechanical stopper, but the standard specification type is without mechanical stopper. Please do not move to the position exceeding the operating range (± 360 degree)

```

<BRAKE>
J1:( 0 )J2:( 0 )J3:( 0 )
J4:( 0 )J5:( 0 )J6:( 1 )
J7:( 0 )J8:( 0 )
REL. 123 CLOSE
    
```

↑

↓

1 '()

-C(J6)
0 SPACE

11) Confirm the axis for which the brakes are to be released.

12) Pressing the [F1] key is kept with the enabling switch of T/B pressed down. The brake is released while pressing the key.

```

<BRAKE>
J1:( 0 )J2:( 0 )J3:( 0 )
J4:( 0 )J5:( 0 )J6:( 1 )
J7:( 0 )J8:( 0 )
REL. 123 CLOSE
    
```

F1

F4

13) Hold the bolts with hands, rotate them slowly and align the ABS mark of the J6 axis with the ABS mark of the wrist area.

14) If the ABS mark is aligned detach the [F1] key and work the brake.

15) Press the [F4] key and return to the origin / brake screen.

```

<ORIGIN/BRAKE>
1. ORIGIN 2. BRAKE
REL. 123 CLOSE
    
```

```

<ORIGIN/BRAKE>
1. ORIGIN 2. BRAKE
REL. 123 CLOSE
    
```

1 '()

16) Press the [1] key , and display the Origin setting selection screen.

```

<ORIGIN>
1. DATA 2. MECH
3. TOOL 4. ABS
5. USER
REL. 123 CLOSE
    
```

+Z(J3)
3 DEF

17) Press the [3] key , and display the Tool selection screen.

```

<TOOL>
J1:( 0 )J2:( 0 )J3:( 0 )
J4:( 0 )J5:( 1 )J6:( 1 )
J7:( 0 )J8:( 0 )
REL. 123 CLOSE
    
```

↑

↓

1 '()

-C(J6)
0 SPACE

EXE

18) Press the [Arrow] key, move the cursor, and set "1" to the J5 axis and J6 axis. Set [0] to other axes.

19) Press the [EXE] key , and display Confirmation screen.

```

<ORIGIN> TOOL
CHANGE TO ORIGIN. OK?
Yes 123 No

```

F1

20) Press the [F1] key, and the origin position is set up.

21) Setting of the origin is completed.

```

<TOOL> COMPLETED
J1: ( 0 ) J2: ( 0 ) J3: ( 0 )
J4: ( 0 ) J5: ( 1 ) J6: ( 1 )
J7: ( 0 ) J8: ( 0 )
REL. 123 CLOSE

```

22) Refer to [Page 187](#), "5.6.5 Recording the origin data" in this manual, and record the origin data on the origin data seal.

The origin settings are completed by the jig method.

◆◆◆ Release the brake ◆◆◆

Do cursor movement into the parenthesis of each axis by the arrow key. The brakes can be released only for the axis for which a "1" is displayed on the screen. If the brakes are not to be released, press the [0] key and display a "0". If the [F1] key on the teaching pendant or the enabling switch is detached while the brakes are released, the brakes will be work immediately.

◆◆◆ Select the axis of origin setting ◆◆◆

Do cursor movement into the parenthesis of each axis by the arrow key. The origin is set only for the axis for which a "1" is displayed on the screen. If the origin is not to be set, press the [0] key and display a "0".

5.6.3 ABS origin method

When the origin setting of the robot is performed for the first time, this product records the angular position of the origin within one rotation of the encoder as the offset value. If the origin setting is performed according to the ABS origin method, this value is used to suppress variations in the origin setting operations and to reproduce the initial origin position accurately.

This operation is carried out with the teaching pendant. Set the mode of the controller to "MANUAL", and set the [ENABLE] switch on the teaching pendant to "ENABLE" to enable the teaching pendant.

First, set to the ABS mark arrow of the axis for which the origin is to be set with jog operation. This can be set for all axes simultaneously or each axis independently.

To align the ABS marks, view the robot from the front. The deviation between the end points of the two triangular marks must be 1 mm or less.

The positions where the ABS mark is attached are shown in below. Refer to Page 26, "2.3 Confirming the operation" for details on the jog operation.

(1) RV-2FR series

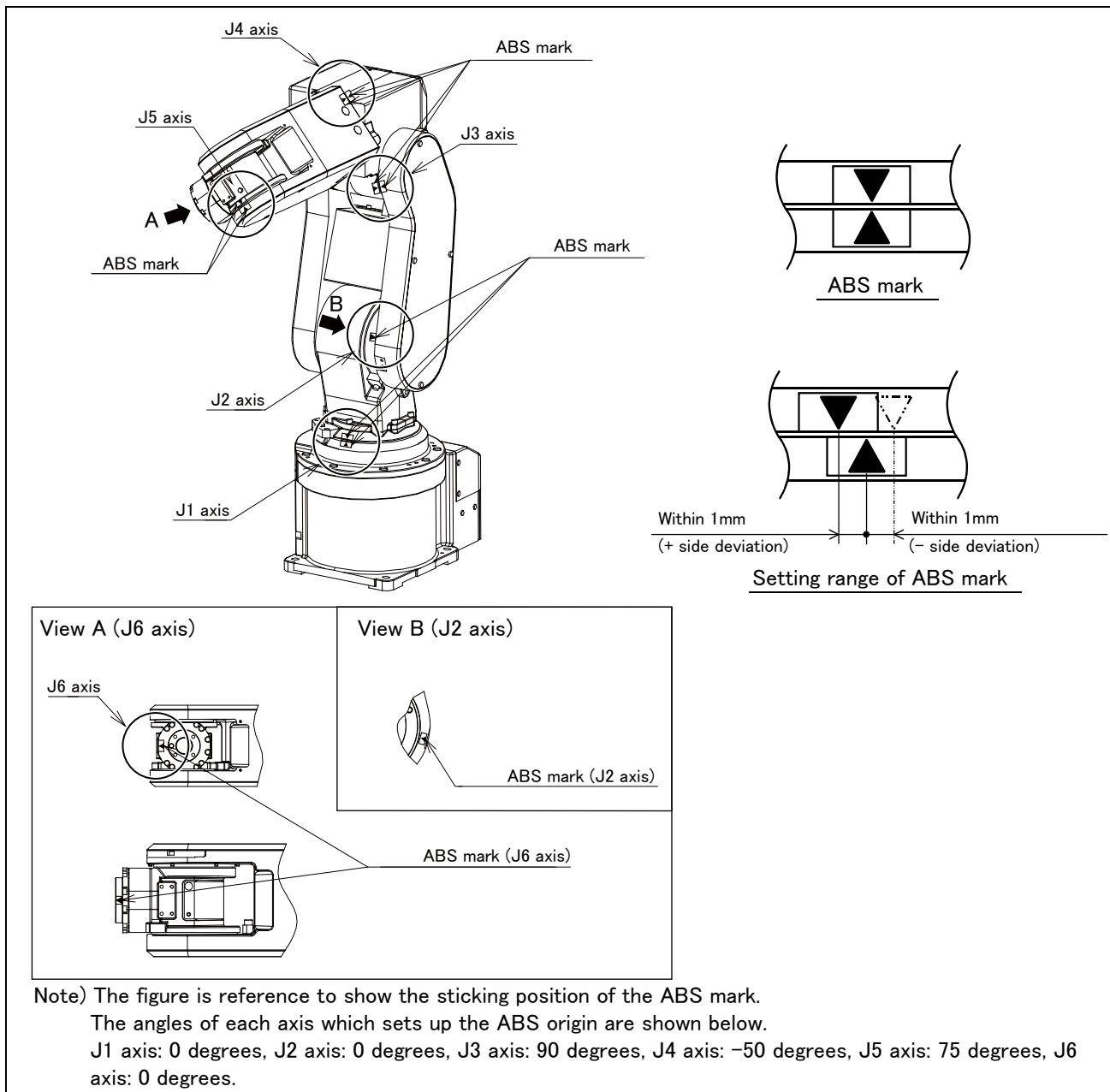

Fig.5-36 : ABS mark attachment positions (RV-2FR series)

(2) RV-4FR series

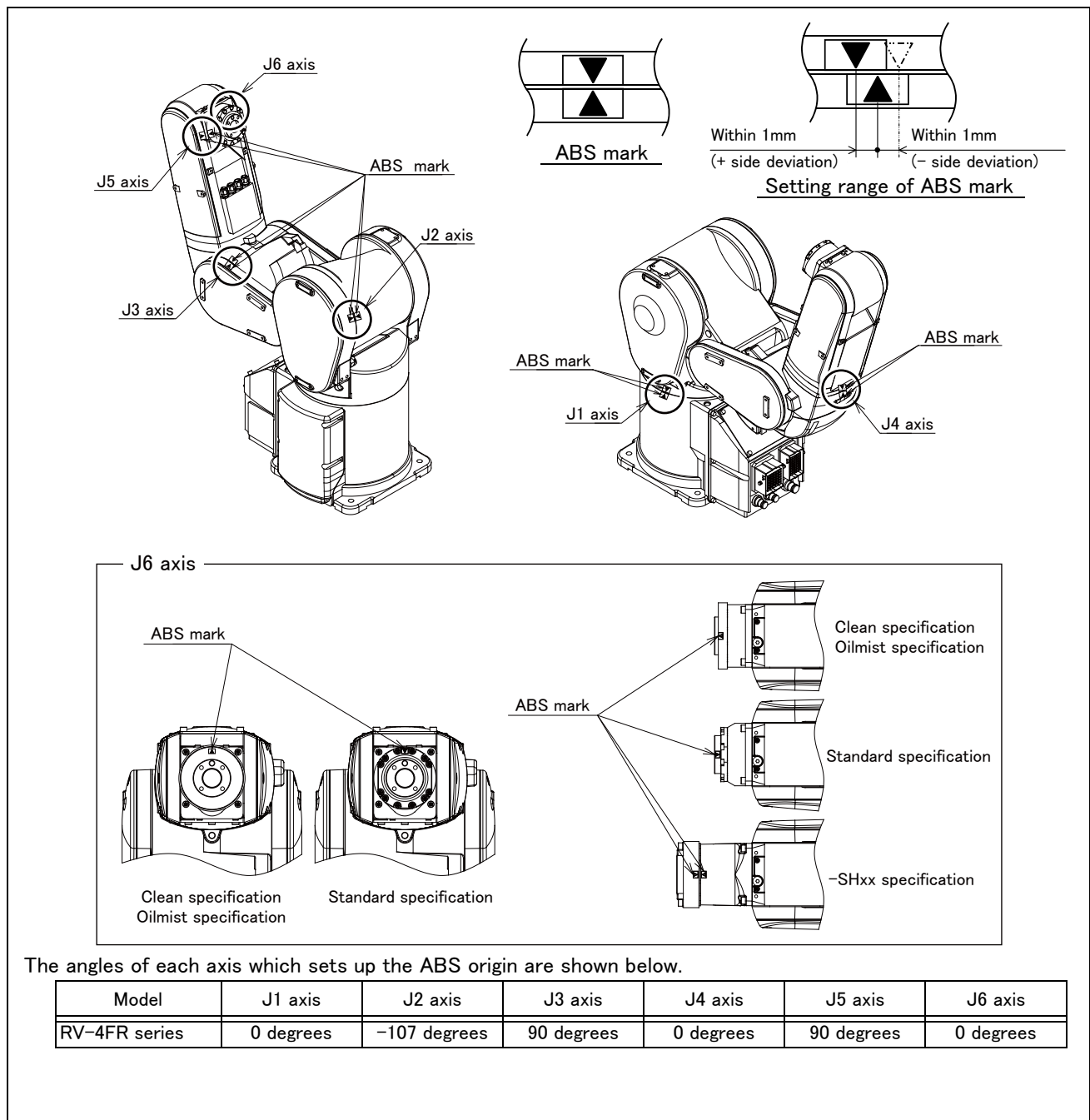

Fig.5-37 : ABS mark attachment positions (RV-4FR series)

(3) RV-7FR series

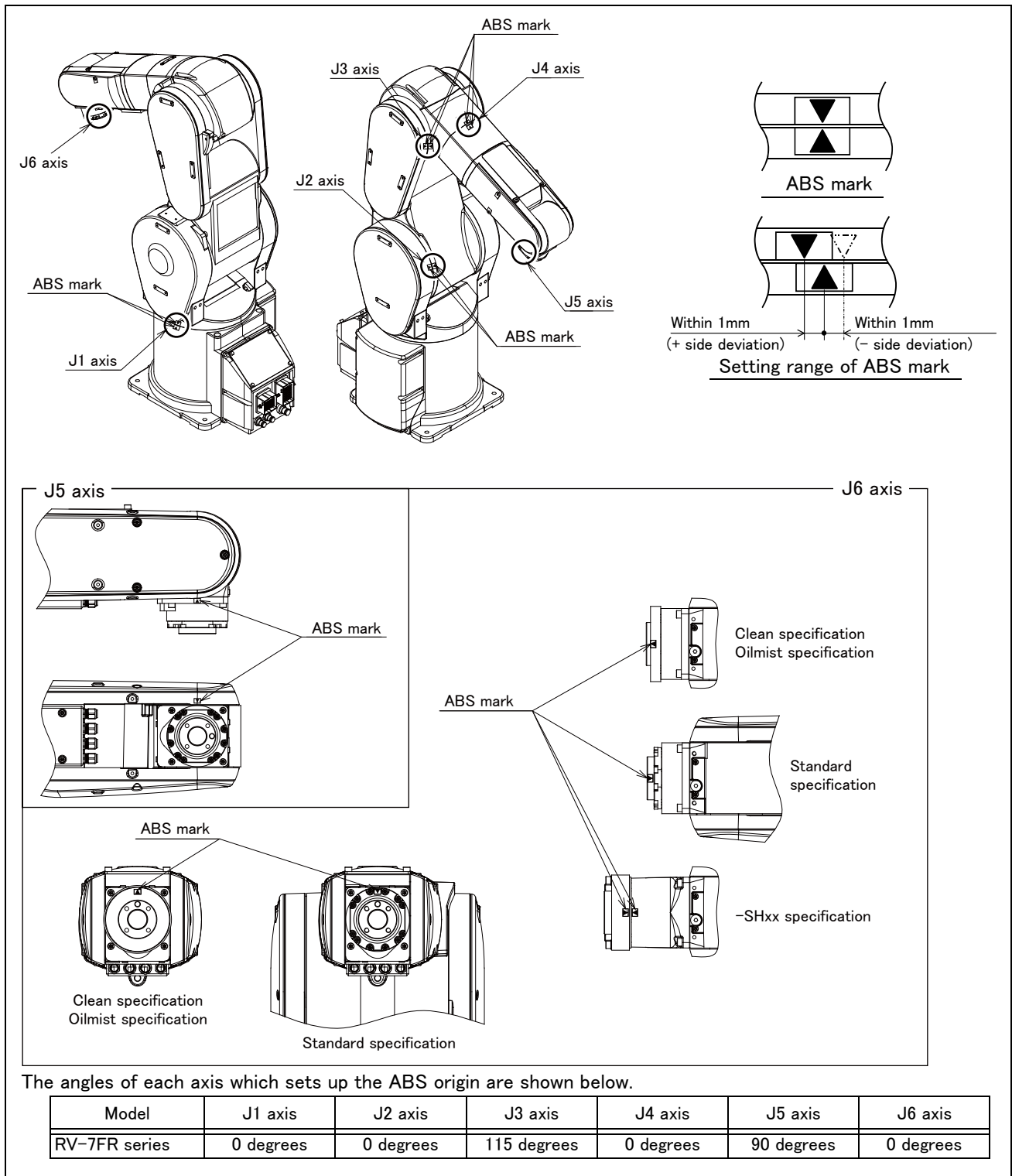

Fig.5-38 : ABS mark attachment positions (RV-7FR series)

(4) RV-13FR series

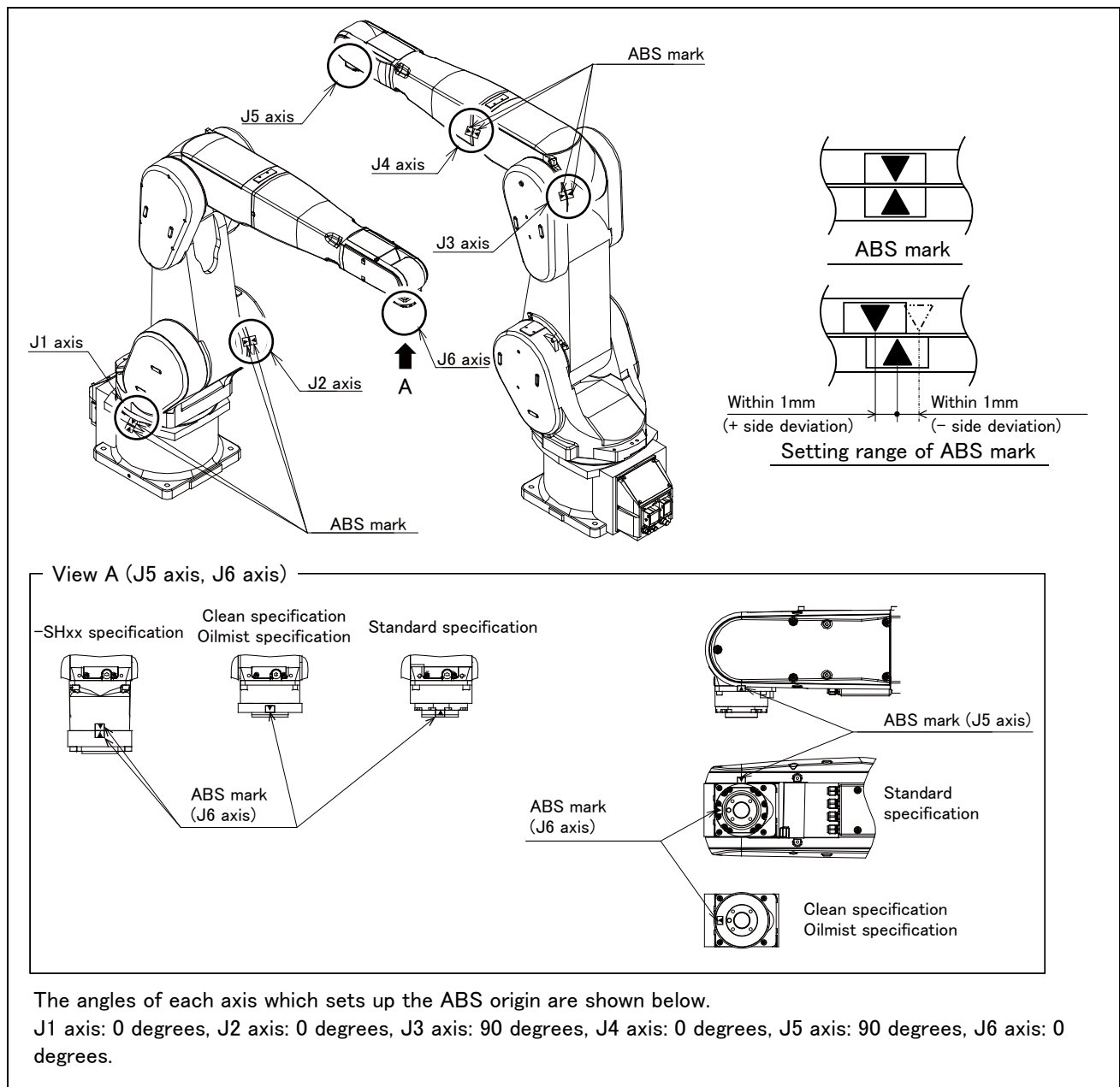
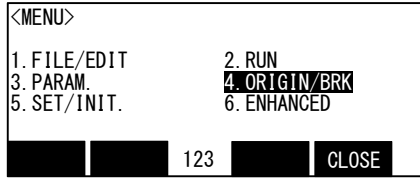

Fig.5-39 : ABS mark attachment positions (RV-13FR series)

(5) Origin setting procedure

Do the following operations with pressing the enabling switch of T/B lightly.



1) Press the [4] key on the menu screen, and display the Origin/Brake selection screen.

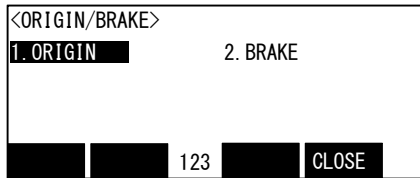

2) Press the [1] key, and display the Origin setting selection screen.

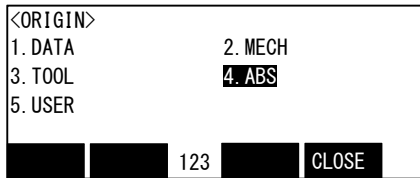

3) Press the [4] key, and display the ABS selection screen.

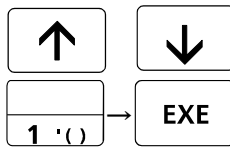
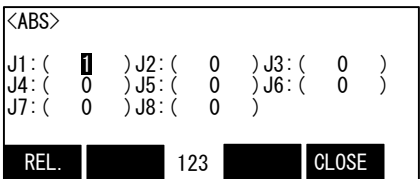

4) Input "1" into the axis to origin setting. Press the [EXE] key, and display Confirmation screen. Note) Always perform origin setting of the J5 axis and the J6 axis simultaneously.

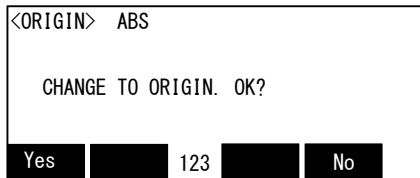

5) Press the [F1] key, and the origin position is set up.

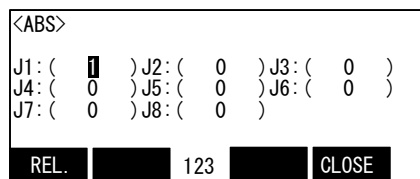

6) Refer to [Page 187](#), "5.6.5 Recording the origin data" in this manual, and record the origin data on the origin data seal.



CAUTION

After setting the origin, when the joint coordinates of the ABS mark position deviate from the coordinates of the ABS origin by 1.5° or more, align the end points of the ABS marks and set the origin using the ABS origin method again.



CAUTION

If the ABS marks on axes other than the J6 axis have peeled off, set the origin using the ABS origin method with the robot in the same posture used for the jig method. The joint coordinates are the same between the ABS origin method and the jig method.

5.6.4 User origin method

**CAUTION**

Before using this method, the origin must be set with the other method.
The setting method is explained in [Page 155, "Table 5-15 : Origin setting method"](#).

The procedure for setting the origin with the user origin method is explained below.

This operation is carried out with the teaching pendant. Set the [ENABLE] switch on the teaching pendant to "ENABLE" to enable the teaching pendant.

The operation method is shown below.

The operation method is shown below.

Software version "C2j" or later has the "user origin data setting specification parameter (UORGSPEC)". Changing the setting value to "1" (high accuracy) will perform compensation considering sagging due to the gravity applied to the robot. This improves the accuracy of setting the origin with this method.

However, if the setting value is changed to "1" (high accuracy), reset the user origin position and origin.

With software version earlier than "C2j", after setting the user origin position and changing the parameter (UORGSPEC) to "1" (high accuracy), setting the origin will deteriorate the accuracy. Therefore, perform the above steps without fail.

This function is available for the RV-FR series. As the RH-FRH series are not subject to sagging, the settings are not effective.

When setting the origin for the first time using this method, carry out the operations in order from step "1)". For the second and following time, move the robot arm to the user origin position with jog operation, and accurately position all axes. Then start the procedure from step "4)".

- 1) Determine the user origin position

Operations required before configuring the settings

The same hand and workpiece conditions must be applied for the user origin position and user origin settings. Be sure to perform the following operations.

- Disable the "robot mechanism thermal compensation function".
- Set the hand and workpiece conditions (HNDDAT0, WRKDAT0) beforehand.

Move the robot to the position to be set as the origin with jog operation. Refer to [Page 26, "2.3 Confirming the operation"](#) for details on the jog operation.

**CAUTION**

Choose the user origin position as the position where it doesn't move by the gravity.
This position is left as a guideline to position all axes with jog operation when setting the origin again with this method.

- 2) Enter the JOINT jog mode, and display the joint coordinates on the teaching pendant screen. Record the value of the axis for which the origin is to be set.
- 3) Input the value recorded in the "user designated origin parameter (USERORG)".
The parameter details and input methods are described in the separate "Instruction Manual/Detailed Explanation of Functions and Operations". Refer to that manual and input the user designated origin position.

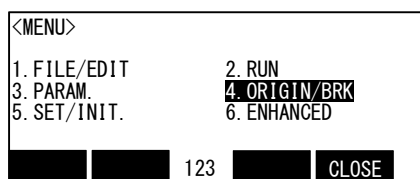

Before performing step 4), refer to [Page 185, "Operations required before configuring the settings"](#).

- 4) Next, set the origin.
Display the menu screen.

- 5) Press the [4] key on the menu screen, and display the Origin/Brake selection screen.

6) Press the [1] key, and display the Origin setting selection screen.

7) Press the [5] key, and display the User selection screen.

8) Input "1" into the axis to origin setting. Press the [EXE] key, and display Confirmation screen.

9) Press the [F1] key, and the origin position is set up.

10) Refer to [Page 187](#), "5.6.5 Recording the origin data" in this manual, and record the origin data on the origin data seal.

The origin settings are completed by the user origin method.

5.6.5 Recording the origin data

Confirm the origin data on the teaching pendant screen (origin data input screen). The origin data label is enclosed with the following cover.

Robot model	Cover
RV-2FR series	J1 motor cover
RV-4FR/7FR/13FR series	CONBOX cover

The teaching pendant operation method and the cover removal method for confirming the origin data is the same as the methods for setting the origin with the origin data input method. Refer to [Page 156, "5.6.1 Setting the origin with the origin data input method"](#), and write the origin data displayed on the teaching pendant onto the origin label.

(1) Confirming the origin data label

Remove the cover.

Refer to [Page 103, "5.3.2 Installing/removing the cover"](#), and remove the cover.

(2) Confirming the origin data

Confirm the value displayed on the teaching pendant's Origin Data Input screen.

Refer to [Page 156, "5.6.1 Setting the origin with the origin data input method"](#), ["\(3\)Inputting the origin data"](#), and display the Origin Data Input screen on the teaching pendant display screen.

(3) Recording the origin data

Write the origin data displayed on the teaching pendant to the origin data label.

Refer to [Page 156, "Fig.5-33 : Origin data label \(an example\)"](#) for details on the origin data label.

(4) Installing the cover

Install the cover removed in step ["\(1\)Confirming the origin data label"](#) above.

Refer to [Page 103, "5.3.2 Installing/removing the cover"](#), and replace the cover.

5.7 How to release the brake in an emergency

The following describes how to release the brake using the emergency power supply in an emergency. Using an emergency power supply system separated from the primary power supply of the robot prevents the robot from moving accidentally during the brake release operation, which contributes to enhancing customer safety.

An emergency here means an emergency stop of robot operation, which requires the brake release operation to set the robot in an evacuation posture temporarily.

[Note] Do not connect an emergency power supply to multiple robots and release their brakes at the same time.

- 1) Connect the teaching pendant to the robot controller.
- 2) Connect the 24V DC power supply to EXT1 of the controller as shown in the figure below.
To prevent accidental power supply from the primary power supply of the robot, prepare an emergency power supply system separated from the primary power supply of the robot to supply AC power to the 24V DC power supply.

[Note] For using the CR800-R/Q controller, it is necessary to turn on the primary power supply of the robot CPU system (PLC). But, do not turn on the primary power supply of the CR800-R/Q controller.

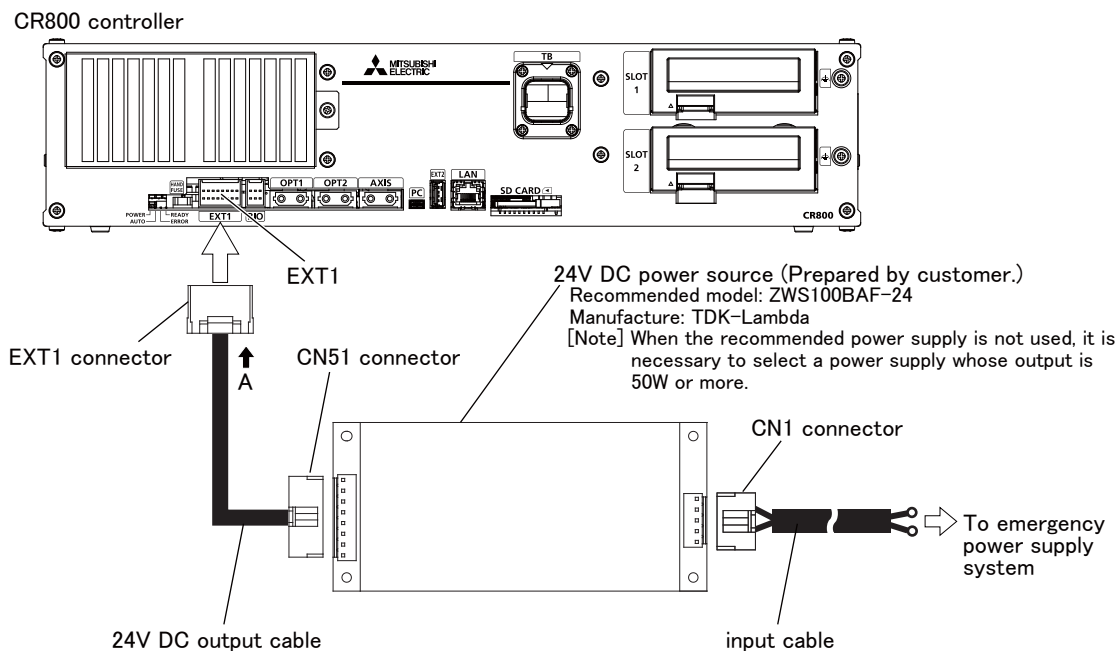

The following shows the connector specifications.

EXT1 connector
Connector: J21DF-16V-KX
Contact: SJ2F-01GF-P1.0
Manufacture: JST

CN51 connector (recommended)
Connector: VHR-8N
Contact: SVH-41T-P1.1
Manufacture: JST

CN1 connector (recommended)
Connector: VHR-5N
Contact: SVH-41T-P1.1
Manufacture: JST

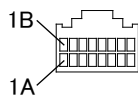

Pin assignment

Pin number	Signal name
8A	24V
8B	
3B	
7A	GND
7B	
3A	

Pin assignment

Pin number	Signal name
1	GND
2	
3	
4	
5	24V
6	
7	
8	

Pin assignment

Pin number	Signal name
1	L
3	N
5	FG

- 3) When the 24V DC power supply is turned on, the controller starts and then errors (H0712, H0090, H0212) will occur.
[Note] For using the R800-R/Q controller, turn ON the 24V DC power supply, then the robot CPU system power on.
- 4) Release the brake using the teaching pendant.
For the brake release operation using the teaching pendant, refer to "Explanation of operation methods" in the separate volume, "Instruction Manual/Detailed Explanations of Functions and Operations".

6 Appendix

Appendix 1 : Configuration flag

The configuration flag indicates the robot posture.

For the robot, the robot hand end is saved with the position data configured of X, Y, Z, A, B and C. However, even with the same position data, there are several postures that the robot can change to. The posture is expressed by this configuration flag, and the posture is saved with FL1 in the position constant (X, Y, Z, A, B, C) (FL1, FL2).

The types of configuration flags are shown below.

(1) RIGHT/LEFT

R is center of flange in comparison with the plane through the J1 axis vertical to the ground. (5-axis type robot)

P is center of J5 axis rotation in comparison with the plane through the J1 axis vertical to the ground. (6-axis type robot)

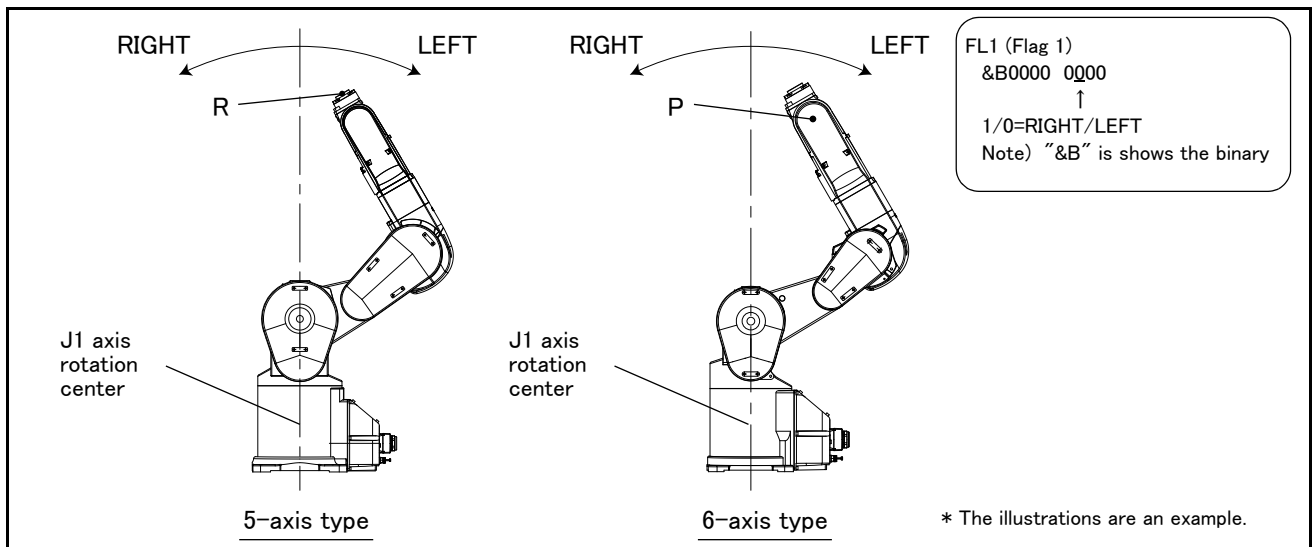

Fig.6-1 : Configuration flag (RIGHT/LEFT)

(2) ABOVE/BELOW

P is center of J5 axis rotation in comparison with the plane through both the J3 and the J2 axis.

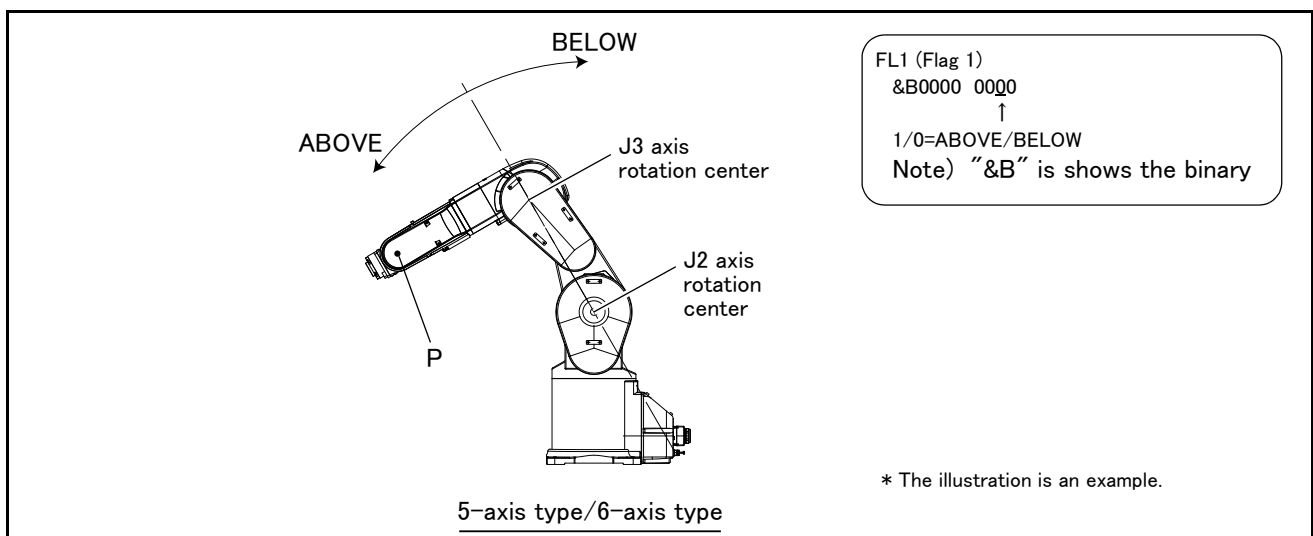

Fig.6-2 : Configuration flag (ABOVE/BELOW)

(3) NONFLIP/FLIP (6-axis type robot only)

This means in which side the J6 axis is in comparison with the plane through both the J4 and the J5 axis.

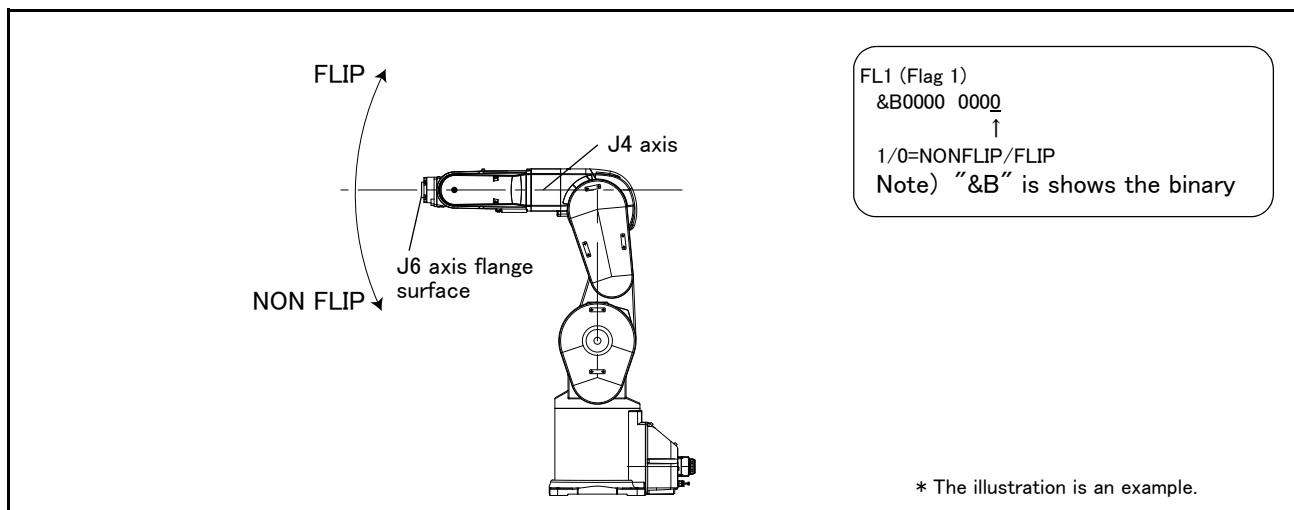

Fig.6-3 : Configuration flag (NONFLIP/FLIP)

mitsubishi electric corporation

HEAD OFFICE: TOKYO BLDG., 2-7-3, MARUNOUCHI, CHIYODA-KU, TOKYO 100-8310, JAPAN
NAGOYA WORKS: 1-14, YADA-MINAMI 5-CHOME, HIGASHI-KU, NAGOYA 461-8670, JAPAN