



Changes for the Better

Mitsubishi Electric Corporation **Industrial** Robot

BFP-A6079-0190E-D

MELFA Technical News

Sep. 2021

Subject: Precautions of replacement from MELFA F series D type robot to FR series D type robot.

Applicable to: RV-2, 4, 7, 13, 20F-D, RH-3, 6, 12, 20FHxxzz-D, RH-3FHR35zz-D
RV-2, 4, 7, 13, 20FR-D, RH-3, 6, 12, 20FRHxxzz-D, RH-3FRHR35zz-D

Thank you for your continued support of Mitsubishi industrial robot MELFA series.
This Technical News explains the detailed precautions of replacement from MELFA F series D type robot to FR series D type robot.

Contents

1. Configurations of the models (Compatible model for replacement)	2
2. Specifications comparison	5
2. 1 Specifications of the robot arm	5
2. 2 Specifications of the controller	8
2. 3 Outside dimensions of the controller	9
2. 4 Options	10
3. Comparing other specifications	11

MITSUBISHI ELECTRIC CORPORATION

1. Configurations of the models (Compatible model for replacement)

The following shows the compatible models of robot arm and controller for replacement from the conventional model of RV-F series D type to RV-FR series D type.

RV-2F-D	CR750-02VD-1	RV-2FR-D	CR800-02VD
RV-2FL-D		RV-2FRL-D	
RV-2FB-D		RV-2FRB-D	
RV-2FLB-D		RV-2FRLB-D	
RV-2F-1D	CR751-02VD-0	RV- □ FR-D	CR800- □ VD
RV-2FL-1D		RV-20FR-D	CR800-20VD
RV-2FB-1D		RV- □ FRL-D	CR800- □ VD
RV-2FLB-1D		RV-4FRJL-D	CR800-04VJD
RV- □ F-D	CR750- □ VD-1	RV-7FRLL-D	CR800-07VLD
RV-20F-D	CR750-20VD-1	RV- □ FR-D-SH	CR800- □ VD
RV- □ FL-D	CR750- □ VD-1	RV-20FR-D-SH	CR800-20VD
RV-4FJL-D	CR750-04VJD-1	RV- □ FRL-D-SH	CR800- □ VD
RV-7FLL-D	CR750-07VLD-1	RV-4FRJL-D-SH	CR800-04VJD
RV- □ F-D-SH	CR750- □ VD-1	RV-7FRLL-D-SH	CR800-07VLD
RV-20F-D-SH	CR750-20VD-1	RV- □ FRM-D	CR800- □ VD
RV- □ FL-D-SH	CR750- □ VD-1	RV-20FRM-D	CR800-20VD
RV-4FJL-D-SH	CR750-04VJD-1	RV- □ FRLM-D	CR800- □ VD
RV-7FLL-D-SH	CR750-07VLD-1	RV-4FRJLM-D	CR800-04VJD
RV- □ FM-D	CR750- □ VD-1	RV-7FRLLM-D	CR800-07VLD
RV-20FM-D	CR750-20VD-1	RV- □ FRC-D	CR800- □ VD
RV- □ FLM-D	CR750- □ VD-1	RV-20FRC-D	CR800-20VD
RV-4FJLM-D	CR750-04VJD-1	RV- □ FRLC-D	CR800- □ VD
RV-7FLLM-D	CR750-07VLD-1	RV-4FRJLC-D	CR800-04VJD
RV- □ FC-D	CR750- □ VD-1	RV-7FRLLC-D	CR800-07VLD
RV-20FC-D	CR750-20VD-1		
RV- □ FLC-D	CR750- □ VD-1		
RV-4FJLC-D	CR750-04VJD-1		
RV-7FLLC-D	CR750-07VLD-1		
RV- □ F-1D	CR751- □ VD-0		
RV-20F-1D	CR751-20VD-0		
RV- □ FL-1D	CR751- □ VD-0		
RV-4FJL-1D	CR751-04VJD-0		
RV-7FLL-1D	CR751-07VLD-0		
RV- □ F-1D-SH	CR751- □ VD-0		
RV-20F-1D-SH	CR751-20VD-0		
RV- □ FL-1D-SH	CR751- □ VD-0		
RV-4FJL-1D-SH	CR751-04VJD-0		
RV-7FLL-1D-SH	CR751-07VLD-0		
RV- □ FM-1D	CR751- □ VD-0		
RV-20FM-1D	CR751-20VD-0		
RV- □ FLM-1D	CR751- □ VD-0		
RV-4FJLM-1D	CR751-04VJD-0		
RV-7FLLM-1D	CR751-07VLD-0		
RV- □ FC-1D	CR751- □ VD-0		
RV-20FC-1D	CR751-20VD-0		
RV- □ FLC-1D	CR751- □ VD-0		
RV-4FJLC-1D	CR751-04VJD-0		
RV-7FLLC-1D	CR751-07VLD-0		

□ in the robot type name indicates the payload of the robot. "4" for 4kg, "7" for 7kg, and "13" for 13kg. □ in the controller type name is "04", "07", and "13".

1. Configurations of the models (Compatible model for replacement) (Continuation)

The following shows the compatible models of robot arm and controller for replacement from the conventional model of RH-FH series D type to RH-FRH series D type.

RH-6FH3520-D	CR750-06HD-1		RH-6FRH3520-D	CR800-06HD
RH-6FH4520-D			RH-6FRH4520-D	
RH-6FH5520-D			RH-6FRH5520-D	
RH-6FH3534-D			RH-6FRH3534-D	
RH-6FH4534-D			RH-6FRH4534-D	
RH-6FH5534-D			RH-6FRH5534-D	
RH-6FH3520C-D			RH-6FRH3520C-D	
RH-6FH4520C-D			RH-6FRH4520C-D	
RH-6FH5520C-D			RH-6FRH5520C-D	
RH-6FH3534C-D			RH-6FRH3534C-D	
RH-6FH4534C-D			RH-6FRH4534C-D	
RH-6FH5534C-D			RH-6FRH5534C-D	
RH-6FH3520M-D			RH-6FRH3520M-D	
RH-6FH4520M-D			RH-6FRH4520M-D	
RH-6FH5520M-D			RH-6FRH5520M-D	
RH-6FH3534M-D			RH-6FRH3534M-D	
RH-6FH4534M-D			RH-6FRH4534M-D	
RH-6FH5534M-D	RH-6FRH5534M-D			

RH-12FH5535-D	CR750-12HD-1		RH-12FRH5535-D	CR800-12HD
RH-12FH7035-D			RH-12FRH7035-D	
RH-12FH8535-D			RH-12FRH8535-D	
RH-12FH5545-D			RH-12FRH5545-D	
RH-12FH7045-D			RH-12FRH7045-D	
RH-12FH8545-D			RH-12FRH8545-D	
RH-12FH5535C-D			RH-12FRH5535C-D	
RH-12FH7035C-D			RH-12FRH7035C-D	
RH-12FH8535C-D			RH-12FRH8535C-D	
RH-12FH5545C-D			RH-12FRH5545C-D	
RH-12FH7045C-D			RH-12FRH7045C-D	
RH-12FH8545C-D			RH-12FRH8545C-D	
RH-12FH5535M-D			RH-12FRH5535M-D	
RH-12FH7035M-D			RH-12FRH7035M-D	
RH-12FH8535M-D			RH-12FRH8535M-D	
RH-12FH5545M-D			RH-12FRH5545M-D	
RH-12FH7045M-D			RH-12FRH7045M-D	
RH-12FH8545M-D	RH-12FRH8545M-D			

RH-20FH8535-D	CR750-20HD-1		RH-20FRH8535-D	CR800-20HD
RH-20FH10035-D			RH-20FRH10035-D	
RH-20FH8545-D			RH-20FRH8545-D	
RH-20FH10045-D			RH-20FRH10045-D	
RH-20FH8535C-D			RH-20FRH8535C-D	
RH-20FH10035C-D			RH-20FRH10035C-D	
RH-20FH8545C-D			RH-20FRH8545C-D	
RH-20FH10045C-D			RH-20FRH10045C-D	
RH-20FH8535M-D			RH-20FRH8535M-D	
RH-20FH10035M-D			RH-20FRH10035M-D	
RH-20FH8545M-D			RH-20FRH8545M-D	
RH-20FH10045M-D	RH-20FRH10045M-D			

RH-3FHR3515-D	CR750-03HRD-1		RH-3FRHR3515-D	CR800-03HRD
RH-3FHR3512C-D			RH-3FRHR3512C-D	
RH-3FHR3512W-D			RH-3FRHR3512W-D	

1. Configurations of the models (Compatible model for replacement) (Continuation)

The following shows the compatible models of robot arm and controller for replacement from the conventional model of RH-FH series D type to RH-FRH series D type.

RH-3FH3515-1D	CR751-03HD-0		RH-3FRH3515-D	CR800-03HD
RH-3FH4515-1D			RH-3FRH4515-D	
RH-3FH5515-1D			RH-3FRH5515-D	
RH-3FH3512C-1D			RH-3FRH3512C-D	
RH-3FH4512C-1D			RH-3FRH4512C-D	
RH-3FH5512C-1D			RH-3FRH5512C-D	

RH-6FH3520-1D	CR751-06HD-0		RH-6FRH3520-D	CR800-06HD
RH-6FH4520-1D			RH-6FRH4520-D	
RH-6FH5520-1D			RH-6FRH5520-D	
RH-6FH3534-1D			RH-6FRH3534-D	
RH-6FH4534-1D			RH-6FRH4534-D	
RH-6FH5534-1D			RH-6FRH5534-D	
RH-6FH3520C-1D			RH-6FRH3520C-D	
RH-6FH4520C-1D			RH-6FRH4520C-D	
RH-6FH5520C-1D			RH-6FRH5520C-D	
RH-6FH3534C-1D			RH-6FRH3534C-D	
RH-6FH4534C-1D			RH-6FRH4534C-D	
RH-6FH5534C-1D			RH-6FRH5534C-D	
RH-6FH3520M-1D			RH-6FRH3520M-D	
RH-6FH4520M-1D			RH-6FRH4520M-D	
RH-6FH5520M-1D			RH-6FRH5520M-D	
RH-6FH3534M-1D			RH-6FRH3534M-D	
RH-6FH4534M-1D			RH-6FRH4534M-D	
RH-6FH5534M-1D			RH-6FRH5534M-D	

RH-12FH5535-1D	CR751-12HD-0		RH-12FRH5535-D	CR800-12HD
RH-12FH7035-1D			RH-12FRH7035-D	
RH-12FH8535-1D			RH-12FRH8535-D	
RH-12FH5545-1D			RH-12FRH5545-D	
RH-12FH7045-1D			RH-12FRH7045-D	
RH-12FH8545-1D			RH-12FRH8545-D	
RH-12FH5535C-1D			RH-12FRH5535C-D	
RH-12FH7035C-1D			RH-12FRH7035C-D	
RH-12FH8535C-1D			RH-12FRH8535C-D	
RH-12FH5545C-1D			RH-12FRH5545C-D	
RH-12FH7045C-1D			RH-12FRH7045C-D	
RH-12FH8545C-1D			RH-12FRH8545C-D	
RH-12FH5535M-1D			RH-12FRH5535M-D	
RH-12FH7035M-1D			RH-12FRH7035M-D	
RH-12FH8535M-1D			RH-12FRH8535M-D	
RH-12FH5545M-1D			RH-12FRH5545M-D	
RH-12FH7045M-1D			RH-12FRH7045M-D	
RH-12FH8545M-1D			RH-12FRH8545M-D	

RH-20FH8535-1D	CR751-20HD-0		RH-20FRH8535-D	CR800-20HD
RH-20FH10035-1D			RH-20FRH10035-D	
RH-20FH8545-1D			RH-20FRH8545-D	
RH-20FH10045-1D			RH-20FRH10045-D	
RH-20FH8535C-1D			RH-20FRH8535C-D	
RH-20FH10035C-1D			RH-20FRH10035C-D	
RH-20FH8545C-1D			RH-20FRH8545C-D	
RH-20FH10045C-1D			RH-20FRH10045C-D	
RH-20FH8535M-1D			RH-20FRH8535M-D	
RH-20FH10035M-1D			RH-20FRH10035M-D	

RH-3FHR3515-1D	CR751-03HRD-0		RH-3FRHR3515-D	CR800-03HRD
RH-3FHR3512C-1D			RH-3FRHR3512C-D	
RH-3FHR3512W-1D			RH-3FRHR3512W-D	

2. Specifications comparison

2. 1 Specifications of the robot arm

Item	F series	FR series
Type	[Vertical multiple-joint type] (e.g.) RV-4F-D (CR750, standard) RV-4F-1D (CR751, standard) RV-4F-D1-S15 (CR750, CE marking) RV-4F-1D1-S15 (CR751, CE marking) [Horizontal multiple-joint type] (e.g.) RH-6FH5520-D (CR750, standard) RH-6FH5520-1D (CR751, standard) RH-6FH5520-D1-S15 (CR750, CE marking) RH-6FH5520-S15 (CR751, CE marking) [Ceiling type] (e.g.) RH-3FHR5515-D (CR750, standard)	The character "F" in the type name has been changed to " FR ". The controllers standardly comply with CE marking requirements. [Vertical multiple-joint type] (e.g.) RV-4 FR -D (CR800-D, standard/CE marking) [Horizontal multiple-joint type] (e.g.) RH-6 FR H5520-D (CR800-D, standard/CE marking) [Ceiling type] (e.g.) RH-3 FR HR5515-D (CR800-D, standard/CE marking)
Machine cable	RV-2/4/7F, RH-FH series ... 5m RV-13/20F series ... 7m	All the machine cables have been unified to 5m in length. In RV-13/20F series, the machine cable has been shortened to 5m from the conventional length.
Connector connection space L Refer to the followings	RV-2F ... 300mm RV-4F ... 366/300mm (CR750/751) RV-7F ... 390/324mm (CR750/751) RV-13F ... 430/375mm (CR750/751) RH-3/6FH ... 200mm (CR750/751) RH-12/20FH ... 240mm (CR750/751) RH-3FHR ... 240/150mm (CR750/751)	RV-2FR ... 300mm RV-4FR ... 300mm RV-7FR ... 324mm RV-13FR ... 375mm RH-3/6FRH ... 200mm RH-12/20FRH ... 240mm RH-3FRHR ... 150mm Same as the CR751

RV-2F(R)

* L indicates the distance to the minimum bending radius of machine cable.

CR750·CR751

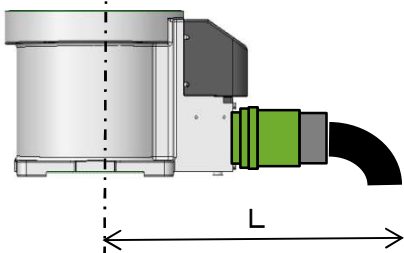

CR800

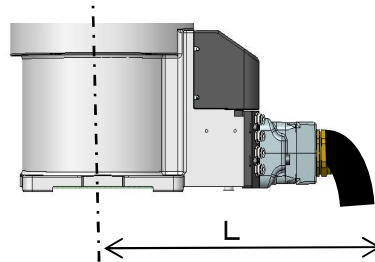

RV-4/7/13/20F(R)

CR750

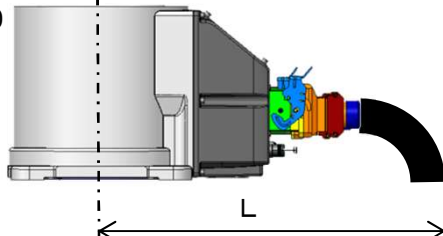

CR800

CR751

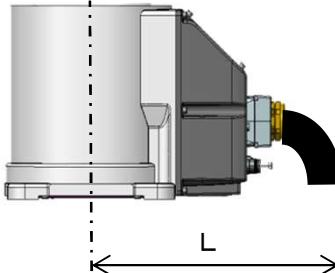
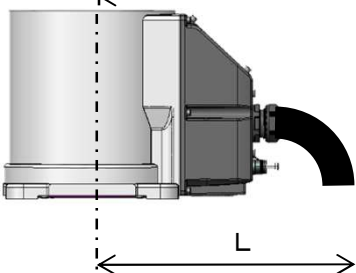

RH-3/6/12/20F(R)H/3F(R)H

CR750

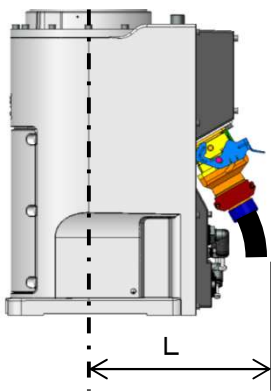

CR751

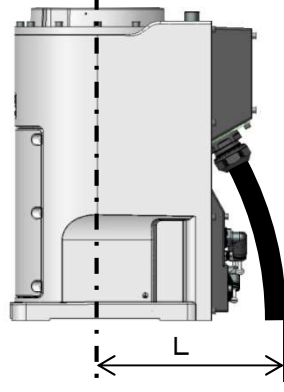

CR800

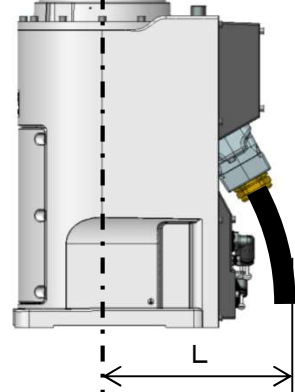

Machine cable comparing table

Item	F series	FR series
Optional extension cable	CR750 ... Extension type CR751 ... Replacement type	Replacement type only
Outside dimensions of connector	[Controller side] RV-2F ... $\phi 41$ (power), $\phi 55$ (signal) CR750 ... $\phi 82$ (power), $\phi 78$ (signal) CR751 ... $\phi 153$ (power), $\phi 50$ (signal) [Robot arm side] RV-2F ... $\phi 41$ (power), $\phi 55$ (signal) CR750 ... $\phi 82$ (power), $\phi 78$ (signal) CR751 ... $\phi 88$ (power), $\phi 85$ (signal)	[Controller side] $\phi 82$ (Equivalent to CR750) [Robot arm side] $\phi 115$ (Increased the outside dimensions from F series.)
Outside diameter of cable	RV-2F ... $\phi 15$ (power), $\phi 8$ (signal) CR750 ... $\phi 24$ (power), $\phi 16$ (signal) CR751 ... $\phi 15$ (power), $\phi 9$ (signal)	$\phi 24$ (Equivalent to CR750)
Outside bending radius R	RV-2F...R100 (power), R68 (signal) CR750... R150 (power), R130 (signal) CR751...R90 (power), R68 (signal)	R150 (Equivalent to CR750)

RV-2F

Connection with the CR750 controller

1) Power cable

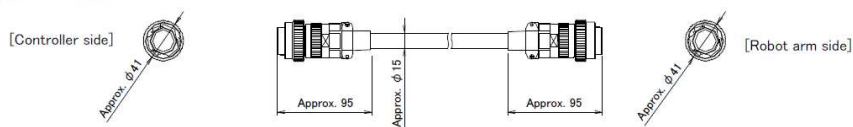

2) Signal cable

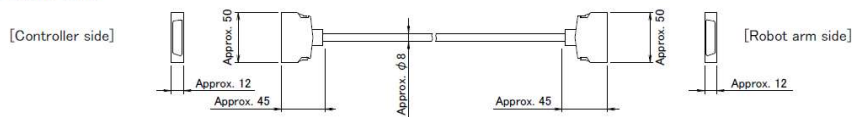

Connection with the CR751 controller

1) Power cable

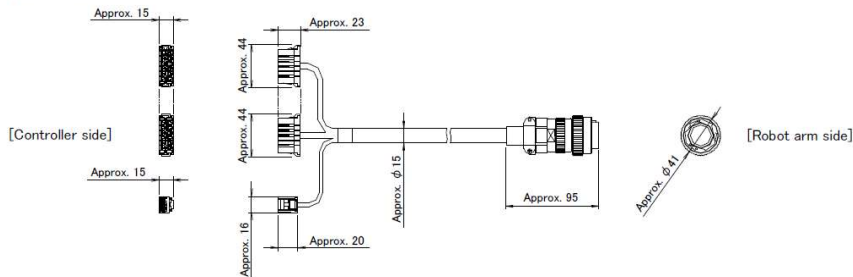

2) Signal cable

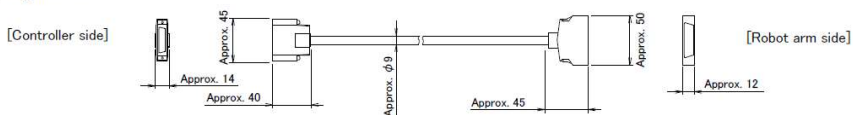

RV-4F/7F/13F/20F, RH-3FH/6FH/12FH/20FH, 3FRH

CR750

1) Power cable

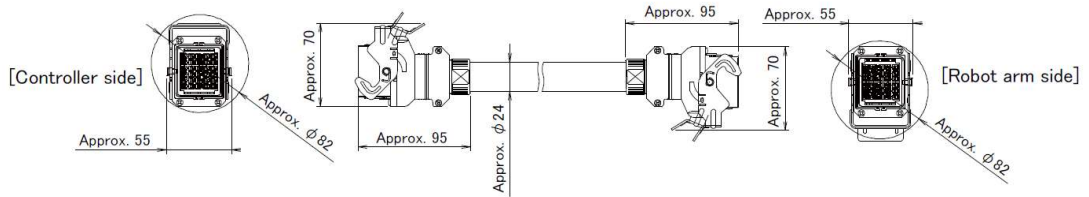

2) Signal cable

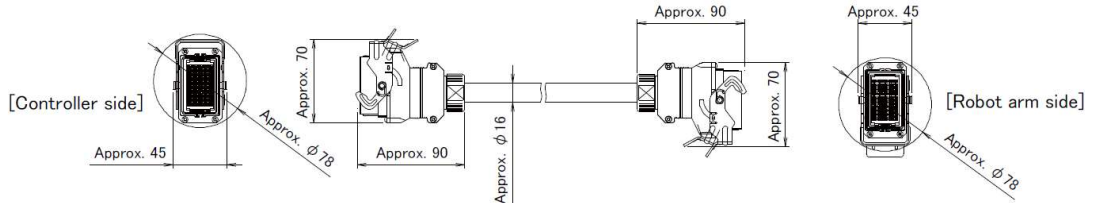

CR751

1) Power cable

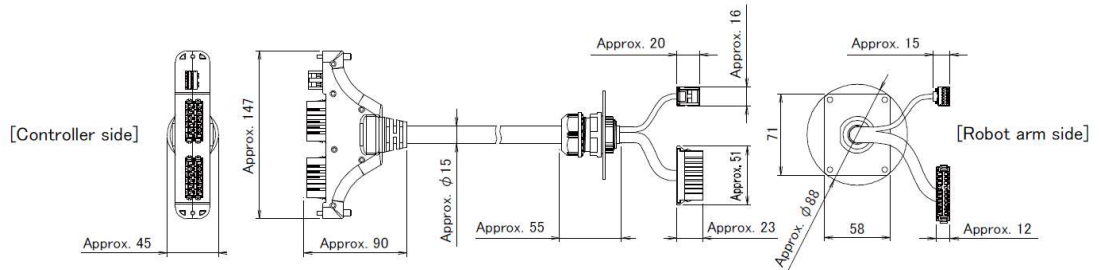

2) Signal cable

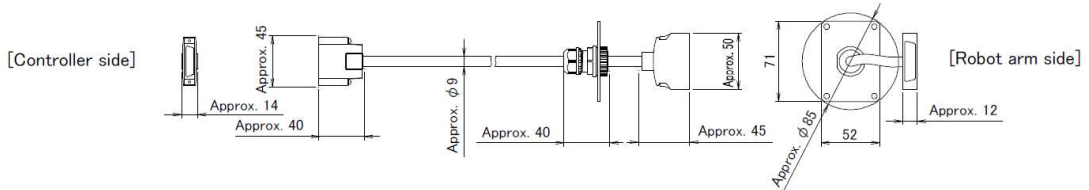

FR series

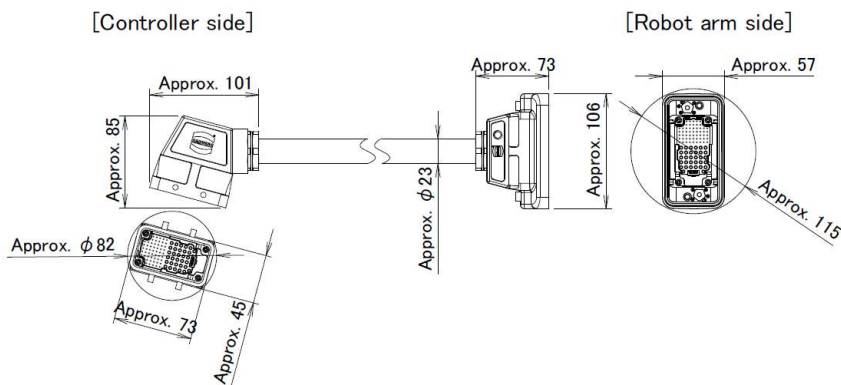

Note: In RV-2FR series, the connector shape has been substantially changed.

Built-in battery of the robot arm

	F series	FR series
Type name ... pcs.	ER6 ... 3 (RH-FH, RV-4/7/13F) ER6 ... 4 (RV-2F)	MR-BAT6V1 ... 4

2. 2 Specifications of the controller

Item		Unit	Specifications CR750/CR751-D	Specifications CR800-D	Remarks
Number of control axis			Simultaneously 6	Simultaneously 6	Additional 8 axes available. (Additional axis function)
Memory capacity	Programmed positions	point	39,000	39,000	
	No. of steps	step	78,000	78,000	
	Number of program		512	512	
Robot language			MELFA-BASIC IV, V	MELFA-BASIC V, VI	
Teaching method			Pose teaching method, MDI method	Pose teaching method, MDI method	
External input and output	Input and output	point	0/0 (Max. 256/256 by option)	0/0 (Max. 256/256 by option)	
	Dedicated input/output		Assigned with general-purpose input/output	Assigned with general-purpose input/output	The signal number of "STOP" input signals is fixing.
	Hand open/close input/output	point	8/8 4/4 in RV-2F series	8/8 4/4 in RV-2FR series	The sink/source type can be switched with parameters
	Emergency stop input	point	1 Note 1)	1 Note 2)	Redundant
	Emergency stop output	point	1	1	
	Enabling device input	point	1	0	
	Mode output	point	1	1	
	Robot error output	point	1	1	
	Addition axis synchronization	point	1	1	
	Mode selector (changeover) switch input	point	1	1	
	Door switch input	point	1	1	
	Encoder input	Channel	2	2	For encoder tracking
	Interface	Additional axis, force sensor interface	Channel	1 (SSCNET III)	1 (SSCNET III/H)
Communication interface between robot controllers		Channel	-	2 (for daisy chaining.)	SSCNET III/H (Optical communication)
Remote input/output		Channel	1 (Ver.1)	1 (Ver.2)	Ver.2 (Compatible with safety control)
USB		port	1 (Ver. 2.0 HighSpeed device functions only. USB mini-B)	1 (Ver. 2.0 HighSpeed device functions only.)	(Ver. 2.0 HighSpeed device functions only.)
Ethernet		port	1 (Dedicated T/B) 1 (For customer) 10BASE-T/100BASE-TX	1 (For customer) 10BASE-T/100BASE-TX/1000BASE-T x1	
				1 (Dedicated T/B) 10BASE-T/100BASE-TX	
Option slot		slot	2	2	For option interface
SD memory card slot		slot	-	1	For logging data. 2GB
RS-422		port	1	1	Dedicated T/B
Input voltage range		V AC	RV-2/4F, RH-3/6FH/3FHR: Single phase AC 200 to 230 RV-7/13/20F, RH-12/20FH: Three phase AC 200 to 230 or Single phase AC 230	RV-2/4/7FR, RH-FRH: Single phase AC 200 to 230 RV-13/20FR Three phase AC 200 to 230 or Single phase AC 230	The rate of power-supply voltage fluctuation is within 10%.
Power supply	Power capacity	KVA	Max. 3	Max. 3	Does not include rush current.
	Power supply frequency	Hz	50/60	50/60	
	Grounding	Ω	100 or less	100 or less	Class D grounding
Ambient temperature	°C	0 to 40	0 to 40		
Ambient humidity	%RH	45 to 85	45 to 85		
Outline dimensions	mm	CR750: 430(W) x 425(D) x 174(H) CR751: RH, RV-2/4/7F 430(W) x 425(D) x 98(H) RV-7FLL/13/20F 430(W) x 425(D) x 174(H)	430(W) x 425(D) x 99.5(H)	Excluding protrusions	
Mass	Kg	CR750: Approx. 18	Approx. 12.5		
		CR751 RV-2/4/7F, RH-3/6/12/20FH: Approx. 12 RV-13F series: Approx. 15			
Construction			Self-contained floortype, Opened type. Installation vertically or horizontally	Self-contained floortype, Opened type. Installation vertically or horizontally	IP20

Note 1) Category3 ,PLd

Note 2) At factory setting, the STO function activated by an external emergency stop input meets the requirements of SIL2, Category3,and PL d. The STO function activated by an external emergency stop input meets the requirements of SIL3, Category4,and PL e when the parameter setting is changed by referring Standard Specification Manual "Appendix 3: Safety diagnosis function(Test pulse diagnosis)".
For details on the functions using external input/output signals,always refer "Appendix 2: Classification of functions using external input/output signals".

2. 3 Outside dimensions of the controller

CR751-D controller

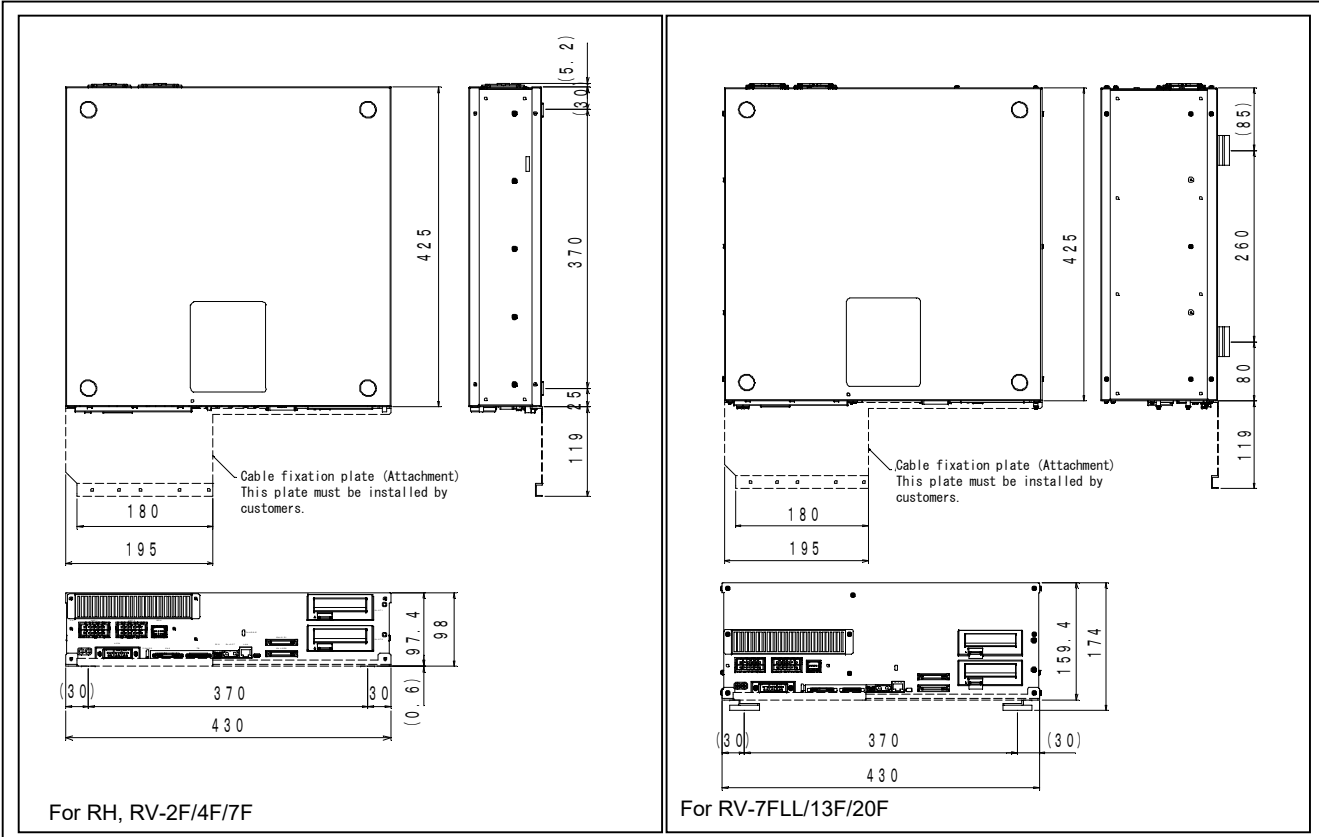

For RH, RV-2F/4F/7F

For RV-7FLL/13F/20F

CR750-D controller

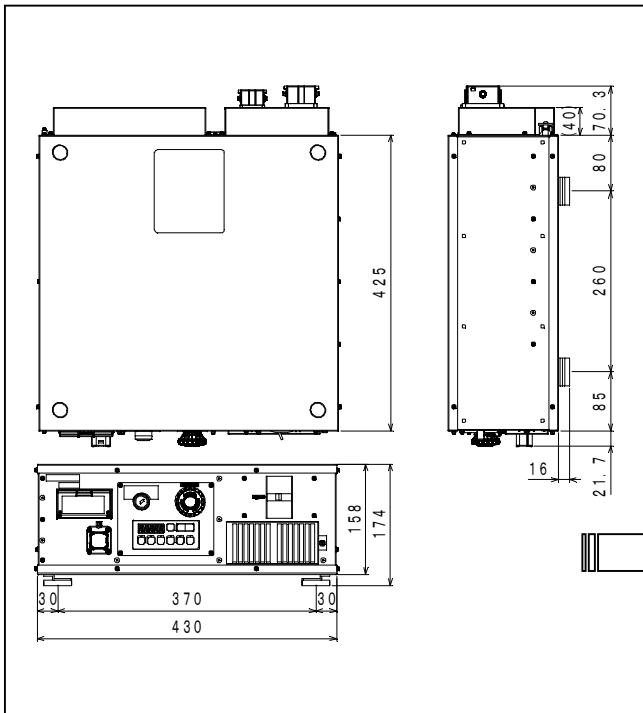

CR800-D controller

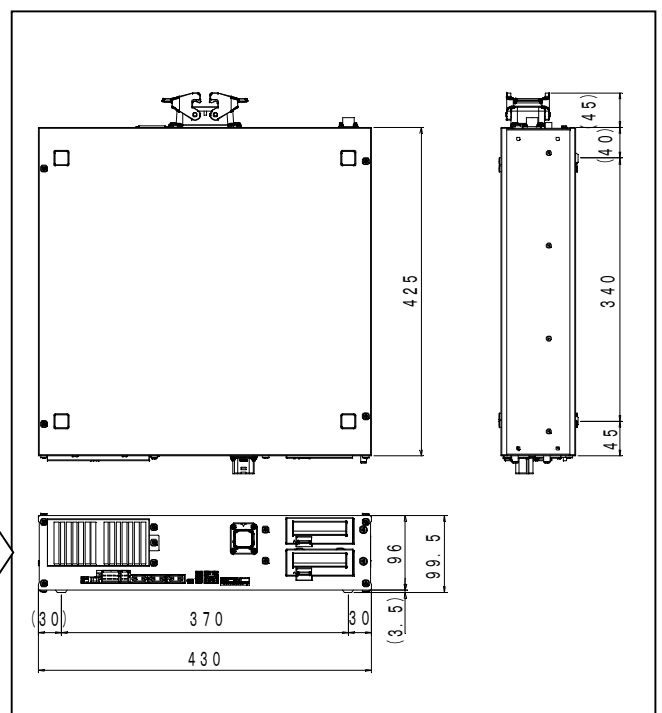

2. 4 Options

Comparing table for robot option

Name	Type	FR series									Classification		Remarks
		RV				RH					Diverted (Same as F series.)	New (Different from F series.)	
		2FR 2FRL	4FR 4FRL	7FR 7FRL	7FRL	13FR 13FRL 20FR	3FRH	6FRH	12FRH 20FRH	3FRHR			
Solenoid valve set	1E-VD0□ (Sink) 1E-VD0□E (Source)	○	—	—	—	—	—	—	—	—	○		□ indicates the number of solenoid valves (1, 2)
	1F-VD0□-02 (Sink) 1F-VD0□E-02 (Source)	—	○	○	○	—	—	—	—	—	○		□ indicates the number of solenoid valves (1, 2, 3, 4)
	1F-VD0□-03 (Sink) 1F-VD0□E-03 (Source)	—	—	—	—	○	—	—	—	—	○		□ indicates the number of solenoid valves (1, 2, 3, 4)
	1F-VD0□-01 (Sink) 1F-VD0□E-01 (Source)	—	—	—	—	—	○	○	—	—	○		□ indicates the number of solenoid valves (1, 2, 3, 4)
	1S-VD0□-01 (Sink) 1S-VD0□E-01 (Source)	—	—	—	—	—	—	—	○	—	○		□ indicates the number of solenoid valves (1, 2, 3, 4)
	1S-VD04-05 (Sink) 1S-VD04E-05 (Source)	—	—	—	—	—	—	—	—	○	○		
	1S-VD04W-05 (Sink) 1S-VD04WE-05 (Source)	—	—	—	—	—	—	—	—	○	○		
Hand output cable	1E-GR35S	○	—	—	—	—	—	—	—	—	○		
	1F-GR35S-02	—	○	○	○	○	—	—	—	—	○		
	1F-GR60S-01	—	—	—	—	—	○	○	○	—	○		
Hand input cable	1S-GR35S-02	—	—	—	—	—	—	—	—	○	○		
	1S-HC30C-11	○	—	—	—	—	—	—	—	—	○		
	1F-HC35S-02	—	○	○	○	○	—	—	—	—	○		
	1F-HC35C-01	—	—	—	—	—	○	○	—	—	○		
	1F-HC35C-02	—	—	—	—	—	—	—	○	—	○		
Hand curl tube	1S-HC00S-01	—	—	—	—	—	—	—	—	○	○		
	1E-ST040□C	○	○	○	○	—	—	—	—	—	○		□ indicates the number of tubes (2, 4, 6, 8) For RV-2F/2FRL, 2 or 4 only.
	1E-ST0408C-300	—	—	—	—	—	○	○	—	—	○		
	1N-ST060□C	—	—	—	—	○	—	—	—	—	○		□ indicates the number of tubes (2, 4, 6, 8)
Hand tube	1N-ST0608C-01	—	—	—	—	—	—	○	—	○			
External wiring set 1 for the forearm	1S-ST0304S	—	—	—	—	—	—	—	○	○			
External wiring set 2 for the forearm	1F-HB01S-01	—	○	○	○	○	—	—	—	—	○		
External wiring set 1 for the base	1F-HB02S-01	—	○	○	○	○	—	—	—	—	○		
External wiring set 2 for the base	1F-HA01S-01	—	○	○	○	○	—	—	—	—	○		
Internal wiring and piping set for hand	1F-HA02S-01	—	○	○	○	○	—	—	—	—	○		
	1F-HS604S-01	—	—	—	—	—	—	—	○	—	○		
	1F-HS604S-02	—	—	—	—	—	—	—	○	—	○		
	1F-HS408S-01	—	—	—	—	—	—	○	—	—	○		
	1F-HS408S-02	—	—	—	—	—	—	○	—	—	○		
External user wiring and piping box	1F-HS304S-01	—	—	—	—	—	○	—	—	—	○		
	1F-UT-BOX	—	—	—	—	—	○	○	—	—	○		
Machine cable (replacement) (Fixed)	1F-UT-BOX-01	—	—	—	—	—	—	○	—	—	○		
	1F-□□ UCBL-41	○	○	○	○	○	○	○	○	○		○ Note □ indicates the length of cable (2, 10, 15, 20m)	
Machine cable (replacement) (Flexed)	1F-□□ LUCBL-41	○	○	○	○	○	○	○	○	○	○ Note □ indicates the length of cable (10, 15, 20m)		
Stopper for changing the J1-axis operating range	1S-DH-11J1	○	—	—	—	—	—	—	—	—	○		
	1F-DH-05J1	—	—	—	○	○	—	—	—	—	○		
	1F-DH-04	—	—	○	—	—	—	—	—	—	○		
	1F-DH-03	—	○	—	—	—	—	—	—	—	○		
	1F-DH-02	—	—	—	—	—	—	—	○	—	○		
	1F-DH-01	—	—	—	—	—	○	○	—	—	○		
Stopper for changing the J2-axis operating range	1S-DH-05J1	—	—	—	—	—	—	—	—	○	○		
	1S-DH-11J2	○	—	—	—	—	—	—	—	—	○		
Stopper for changing the J3-axis operating range	1S-DH-05J2	—	—	—	—	—	—	—	—	○	○		
	1S-DH-11J3	○	—	—	—	—	—	—	—	—	○		





Note

The machine cables are not compatible with the machine cables of F series.

Comparing table for controller

Name	Type	CR750	CR751	CR800	Specifications
Standard teaching pendant (7m, 15m)	R32TB(-**)	○	—	○	7m: Standard, 15m: Custom (" -15" is included in the model name)
High-function teaching pendant (7m, 15m)	R56TB(-**)	○	—	○	7m: Standard, 15m: Custom (" -15" is included in the model name)
Standard teaching pendant (7m, 15m)	R33TB(-**)	—	○	—	7m: Standard, 15m: Custom (" -15" is included in the model name)
High-function teaching pendant (7m, 15m)	R57TB(-**)	—	○	—	7m: Standard, 15m: Custom (" -15" is included in the model name)
Conversion cable for the teaching pendant	2F-32CON03M	—	○	—	Conversion cable used to the R32TB to the CR751 controller. Cable length: 3m.
Conversion cable for the teaching pendant (R33TB -> R32TB)	2F-33CON03M	○	—	○	Conversion cable used to the R32TB/R57TB to the CR800 controller. Cable length: 3m.
Parallel I/O unit	(Sink type) 2A-RZ361	○	○	○	32 output points/32 input points
	(Source type) 2A-RZ371				
External I/O cable (5m, 15m)	2A-CBL**	○	○	○	CBL05: 5m, CBL15: 15m, not terminated at one end. For 2A-RZ361/371.
Parallel I/O interface (Installed internally)	(Sink type) 2D-TZ368	○	○	○	32 output points/32 input points
	(Source type) 2D-TZ378				
External I/O cable (5m, 15m)	2D-CBL**	○	○	○	CBL05: 5m, CBL15: 15m, not terminated at one end. For 2D-TZ368/378.
CC-Link interface	2D-TZ576	○	○	○	CC-Link intelligent device station, Ver. 2.0, 1 to 4 stations
Network base card (EtherNet/IP interface)	2D-TZ535	○	○	○	Communication interface for installing an HMS Anybus-CompactCom module. An HMS EtherNet/IP module (AB6314) must be separately prepared by customers.
Network base card (PROFINET interface)	2D-TZ535-PN	○	○	○	Communication interface for installing an HMS Anybus-CompactCom module. An HMS PROFINET module (AB6489-B) must be separately prepared by customers.
Network base card (CC-Link IE Field interface)	2F-DQ535	—	—	○	Communication interface for installing an HMS Anybus-CompactCom module. An HMS CC-Link IE Field module (AB6709) must be separately prepared by customers.
Network base card (EtherCAT interface)	2F-DQ535-EC	—	—	○	Communication interface for installing an HMS Anybus-CompactCom module. An HMS EtherCAT module (AB6707) must be separately prepared by customers.
MELFA Smart Plus card pack	2F-DQ510/DQ520	—	—	○	This card enables all of A-type/ AB-type intelligence technology functions.
MELFA Smart Plus card	2F-DQ511/DQ521	—	—	○	The card enables one of A-type/ B-type intelligence technology function.
Force sensor set	4F-FS001-W200	○	○	—	Set of devices required for the force control function including a force sensor and interface unit, and support software. This option cannot be used with FR series.
	4F-FS002H-W200				
Force sensor set (Corresponding to SSCNET III/H)	4F-FS002H-W200	—	—	○	Set of devices required for the force control function including a force sensor and interface unit, and support software. This option cannot be used with F series.
	4F-FS002H-W1000				
MELFA-3D Vision	4F-3DVS2-PKG1	○	○	○	Set of devices required for the 3D vision sensor function, including a 3D camera head and control unit (applicable model: RV-F/FR series)
	Additional camera head 4F-3DVS2-OPT1				
Optional visual field expander	2F-3DVS2-OPT2	○	○	○	Visual field expansion of 20 to 28 degrees.
	4F-3DVS2-PKG3				
MELFA-3D Vision 2.0	4F-3DVS2-PKG3	○Note1	○Note1	○Note2	Set of devices required for the 3D vision sensor function, including a 3D camera head and control unit (applicable model: RV-F/FR series).Note1 : This function cannot be used with Recognition parameter automatic adjustment AI. Note2 : Recognition parameter automatic adjustment AI function requires MELFA Smart Plus card.
	Additional camera head 2F-3DVS2-OPT3				
Optional visual field expander	2F-3DVS2-OPT2	○	○	○	Visual field expansion of 20 to 28 degrees.
	3F-53U-WINM				
MELFA-3D Vision 3.0	3F-53U-WINM	○Note1	○Note1	○Note2	MELFA-3D Vision software, Note1 : This function cannot be used with Recognition parameter automatic adjustment AI. Note2 : Recognition parameter automatic adjustment AI function requires MELFA Smart Plus card.
Safety option	4F-SF001-01	○	○	—	Item to support the safety I/O. (This option cannot be used with FR series.)
Safety option	4F-SF002-01	—	—	○	Item to support the safety I/O. (This option cannot be used with F series.)
Terminal block replacement tool for the user wiring	2F-CNUSR01M	—	○	—	Terminal block replacement tool for the wiring for the external input/output, such as emergency input/output, door switch input, and enabling device input.
Encoder distribution unit	2F-YZ581	○	○	○	Unit for connecting one rotary encoder to multiple robot controllers (up to four controllers) when the tracking function is used.
Controller protection box	CR750-MB	○	—	—	With a built-in CR750-D/Q for improved dust-proofing (dedicated CR750)
Controller protection box	CR751-MB	—	○	—	With a built-in CR751-D/Q for improved dust-proofing (dedicated CR751)
Controller protection box	CR800-MB	—	—	○	With a built-in CR800-D/R for improved dust-proofing (dedicated CR800)
Personal computer support software (RT ToolBox2)	3D-11C-WINJ	○	○	—	With simulation function (CD-ROM) (RT ToolBox2)
Personal computer support software –mini (RT ToolBox2)	3D-12C-WINJ	○	○	—	Simple version (CD-ROM) (RT ToolBox2 mini)
RT ToolBox 3 Standard	3F-14C-WINJ	—	—	○	With simulation function (CD-ROM) (RT ToolBox3)
RT ToolBox 3 mini	3F-15C-WINJ	—	—	○	Simple version (CD-ROM) (RT ToolBox3 mini)
RT ToolBox 3 Pro	3F-16D-WINJ	—	—	○	Professional version (DVD-ROM) (RT ToolBox3 Pro)
Simulator (MELFA-Works)	3F-21D-WINJ	○	○	—	Layout study/Tact time study/Program debug. Add-in software for Solidworks® (64 bit compatible, DVD)
Extension memory	2D-TZ454	—	—	—	Extended user program area of 2 MB
SD memory card	2F-2GBSD	—	—	○	For logging data. 2 GB

3. Comparing other specifications

	CR750	CR751	CR800
Mode selector input 	Provided (The key switch is provided on the controller.)	Provided (Customer needs to prepare a mode selector switch.)	Provided (Customer needs to prepare a mode selector switch) Recommended key switch: HA1K-2C2A-2 (manufactured by IDEC)
Enabling device switch input 	Provided 	Provided 	Not provided 
Battery	Using (Q6BAT, 1 pc.)	Using (Q6BAT, 1 pc.)	Not using (Not necessary to replace the battery)
TB dummy connector	Necessary	Necessary	Not necessary After performing the specific operation by T/B, the T/B can be removed even during the automatic operation.

Precautions of the change of controller specifications. (Continuation)

ACIN cable

CR750	CR751	CR800						
<p>Customer preparation ■ The cable is not supplied.</p>	<p>Dedicated cable (supplied)</p> <p>Single phase cable</p> <p>Three phase cable</p> <p> ■ RV-2F/4F, RH-3FH/6FH/3FRH Single phase cable is supplied. </p> <p> ■ RV-7F/13F/20F, RH-12FH/20FH/1FHR Either single or three phase cable is supplied corresponding to the specification. </p>	<p>Dedicated cable (supplied)</p> <table border="1"> <thead> <tr> <th>Number of phase</th> <th>ACIN cable</th> </tr> </thead> <tbody> <tr> <td>Single phase</td> <td> <p>Terminal: M5, cable length: 3m</p> </td> </tr> <tr> <td>Three phase</td> <td> <p>Terminal: M5, cable length: 3m</p> </td> </tr> </tbody> </table> <p> ■ RV-7FRLL/13FR/20FR/3FRH Both two cables (single phase/three phase) are supplied for the robot above. In the other robot, the single phase cable is supplied. </p>	Number of phase	ACIN cable	Single phase	<p>Terminal: M5, cable length: 3m</p>	Three phase	<p>Terminal: M5, cable length: 3m</p>
Number of phase	ACIN cable							
Single phase	<p>Terminal: M5, cable length: 3m</p>							
Three phase	<p>Terminal: M5, cable length: 3m</p>							

Earth leakage barker

CR750	CR751	CR800
<p>Built-in</p>	<p>Customer preparation</p> <p> ■ Recommended model Single phase: NV30FAU-2P-10A-AC100-240V-30mA Three phase: NV30FAU-3P-10A-AC100-240V-30mA </p>	<p>Customer preparation</p> <p> ■ Recommended model Single phase: NV30FAU-2P-10A-AC100-240V-30mA Three phase: NV30FAU-3P-10A-AC100-240V-30mA </p>
<p>RV-2F/4F, RH-3FH/6FH/3FRH: Single phase AC 180 to 253 V</p> <p>RV-7F/13F/20F, RH-12FH/20FH: Three phase AC 180 to 253 V Single phase AC 207 to 253 V The rate of power-supply voltage fluctuation is within 10%.</p>	<p>←</p>	<p>The following models have been changed to single phase specification.</p> <p>RV-7FR, RH-12FRH/20FRH: Single phase AC 200 to 230 V The rate of power-supply voltage fluctuation is within 10%.</p>

Precautions of controller options and change of controller specification (Continuation)

CNUSR connectors

CR750	CR751	CR800
<p>Terminal block</p>	<p>Soldering</p> <p>View A</p>	<p>Terminal block</p> <p>Wiring to a connector</p>

Connection space for connecting the machine cable

Actual space is required to take heat removal into consideration. Refer to "Standard Specifications Manual" or "Controller Setup, Basic operation, and Maintenance" for details.

View from the top.

CR750	CR751	CR800
<p>RV-2F</p> <p>RV-4F/7F/13F/20F, RH-3FH/6FH/12FH/20FH, 3FHR</p> <p>CR750</p> <p>Rear connection of machine cables</p>	<p>RV-2F</p> <p>RV-4F/7F/13F/20F, RH-3FH/6FH/12FH/20FH, 3FHR</p> <p>Front connection of machine cables</p>	<p>RV-2FR/4FR/7FR/13FR/20FR, RH-3FRH/6FRH/12FRH/20FRH, 3FRHR</p> <p>CR800</p> <p>Rear connection of machine cable</p>

Precautions of controller options and change of controller specification (Continuation)

Power supply for the emergency stop switch.

CR750	CR751	CR800
Internal or external power supply.	←	Internal power supply (pulse drive)

Refer to "Emergency stop input and output etc." in Standard Specifications Manual for details.

Pin assignment of dedicated input/output connector (1/2)

Name	Function	CR750	CR751	CR800
		CNUSR12	CNUSR1	CNUSR11
EMGOUT21	Emergency stop output	13	19	3
MODEOUT21	Mode output	11	17	4
OPKEY2COM(24V)	Mode selector switch input	-	-	5
24V2 for GRIP	Enabling device connection	9	10	-
24V2 for DOOR	Connection of door switch	7	9	6
EXTEMG21	Construction of external emergency stop input circuit	2	31	7
		CNUSR2	CNUSR2	CNUSR11
ROBOTERR11	Robot error output	16	16	8
		CNUSR11	CNUSR1	CNUSR11
EMGOUT11	Emergency stop output	13	20	10
MODEOUT11	Mode output	11	18	11
OPKEY1COM(24V)	Mode selector switch input	-	-	12
24V1 for GRIP	Enabling device connection	9	5	-
24V1 for DOOR	Connection of door switch	7	4	13
EXTEMG11	Construction of external emergency stop input circuit	2	26	14
		CNUSR12	CNUSR1	CNUSR11
EMGOUT22	Emergency stop output	14	44	19
MODEOUT22	Mode output	12	42	20
OPKEY2	Mode selector switch input	-	-	21
GRIP2	Enabling device connection	10	35	-
DOOR2	Connection of door switch	8	34	22
EXTEMG22	Construction of external emergency stop input circuit	3	7	23
		CNUSR2	CNUSR2	CNUSR11
ROBOTERR12	Robot error output	41	41	24
		CNUSR11	CNUSR1	CNUSR11
EMGOUT12	Emergency stop output	14	45	26
MODEOUT12	Mode output	12	43	27
OPKEY1	Mode selector switch input	-	-	28
GRIP1	Enabling device connection	10	30	-
DOOR1	Connection of door switch	8	29	29
EXTEMG12	Construction of external emergency stop input circuit	3	2	30

Change of the tracking-related specifications.

Pin assignment of dedicated input/output connector (2/2)

Name	Function	CR750	CR751	CR800	
				CNUSR12	} Note 1
ENC5V	5V for encoder signal	-	-	7	
RG	GND for encoder signal	-	-	16	
		CNUSR13	CNUSR1		} Note 2
LZH1	Z-phase signal + (plus) side of differential encoder CH1	8	23-		
LZL1	Z-phase signal - (minus) side of differential encoder CH1	10	48-		
		CNUSR2	CNUSR2		
LZH2	Z-phase signal + (plus) side of differential encoder CH2	23	23-		
LZL2	Z-phase signal - (minus) side of differential encoder CH2	48	48-		

Note 1:

When using the tracking function, prepare 5V DC power supply for encoder signal. Refer to "Tracking Function Instruction Manual" for details.

Note 2:

Z-phase of encoder is not be used.

Change of controller specifications

	F series	FR series
Robot language	MELFA-BASIC IV MELFA-BASIC V	MELFA-BASIC IV cannot be used directly. (RT3 converts MELFA-BASIC IV into MELFA-BASIC V or VI.) MELFA-BASIC V MELFA-BASIC VI (upper-compatible of MELFA-BASIC V) * In MELFA-BASIC VI, the description method of program is the same as MELFA-BASIC V unless the Function or Include commands are used.
Serial number of robot	Necessary to input (by using the T/B or RT2)	Not necessary to input (The data has been stored in the robot's internal ROM.)
Origin setting	Necessary to input (by using the T/B or RT2)	Not necessary to input (The data has been stored in the robot's internal ROM.)
Hand type	Sink type (initial value) It is necessary to set a parameter for selecting the source type.	Not set (initial value) It is necessary to select either sink or source type by setting a parameter. (If not set, an error will occur.)