

**Mitsubishi Industrial Robot**

**CR750/CR751 series controller**

**Force Sense Function**

**Instruction Manual**

---

**4F-FS001-W200  
4F-FS001-W1000**





## **Safety Precautions**

Always read the following precautions and the separate "Safety Manual" before starting use of the robot to learn the required measures to be taken.

 **CAUTION** All teaching work must be carried out by an operator who has received special training.  
(This also applies to maintenance work with the power source turned ON.)  
→Enforcement of safety training

 **CAUTION** For teaching work, prepare a work plan related to the methods and procedures of operating the robot, and to the measures to be taken when an error occurs or when restarting. Carry out work following this plan.  
(This also applies to maintenance work with the power source turned ON.)  
→Preparation of work plan

 **WARNING** Prepare a device that allows operation to be stopped immediately during teaching work.  
(This also applies to maintenance work with the power source turned ON.)  
→Setting of emergency stop switch

 **CAUTION** During teaching work, place a sign indicating that teaching work is in progress on the start switch, etc.  
(This also applies to maintenance work with the power source turned ON.)  
→Indication of teaching work in progress

 **DANGER** Provide a fence or enclosure during operation to prevent contact of the operator and robot.  
→Installation of safety fence

 **CAUTION** Establish a set signaling method to the related operators for starting work, and follow this method.  
→Signaling of operation start

 **CAUTION** As a principle turn the power OFF during maintenance work. Place a sign indicating that maintenance work is in progress on the start switch, etc.  
→Indication of maintenance work in progress

 **CAUTION** Before starting work, inspect the robot, emergency stop switch and other related devices, etc., and confirm that there are no errors.  
→Inspection before starting work

The points of the precautions given in the separate "Safety Manual" are given below. Refer to the actual "Safety Manual" for details.

**DANGER**

When automatic operation of the robot is performed using multiple control devices (GOT, programmable controller, push-button switch), the interlocking of operation rights of the devices, etc. must be designed by the customer.

**CAUTION**

Use the robot within the environment given in the specifications. Failure to do so could lead to faults or a drop of reliability.  
(Temperature, humidity, atmosphere, noise environment, etc.)

**CAUTION**

Transport the robot with the designated transportation posture. Transporting the robot in a non-designated posture could lead to personal injuries or faults from dropping.

**CAUTION**

Always use the robot installed on a secure table. Use in an instable posture could lead to positional deviation and vibration.

**CAUTION**

Wire the cable as far away from noise sources as possible. If placed near a noise source, positional deviation or malfunction could occur.

**CAUTION**

Do not apply excessive force on the connector or excessively bend the cable. Failure to observe this could lead to contact defects or wire breakage.

**CAUTION**

Make sure that the workpiece weight, including the hand, does not exceed the rated load or tolerable torque. Exceeding these values could lead to alarms or faults.

**WARNING**

Securely install the hand and tool, and securely grasp the workpiece. Failure to observe this could lead to personal injuries or damage if the object comes off or flies off during operation.

**WARNING**

Securely ground the robot and controller. Failure to observe this could lead to malfunctioning by noise or to electric shock accidents.

**CAUTION**

Indicate the operation state during robot operation. Failure to indicate the state could lead to operators approaching the robot or to incorrect operation.

**WARNING**

When carrying out teaching work in the robot's movement range, always secure the priority right for the robot control. Failure to observe this could lead to personal injuries or damage if the robot is started with external commands.

**CAUTION**

Keep the jog speed as low as possible, and always watch the robot. Failure to do so could lead to interference with the workpiece or peripheral devices.

 **CAUTION** After editing the program, always confirm the operation with step operation before starting automatic operation. Failure to do so could lead to interference with peripheral devices because of programming mistakes, etc.

 **CAUTION** Make sure that if the safety fence entrance door is opened during automatic operation, the door is locked or that the robot will automatically stop. Failure to do so could lead to personal injuries.

 **CAUTION** Never carry out modifications based on personal judgments, non-designated maintenance parts. Failure to observe this could lead to faults or failures.

 **WARNING** When the robot arm has to be moved by hand from an external area, do not place hands or fingers in the openings. Failure to observe this could lead to hands or fingers catching depending on the posture.

 **CAUTION** Do not stop the robot or apply emergency stop by turning the robot controller's main power OFF. If the robot controller main power is turned OFF during automatic operation, the robot accuracy could be adversely affected. Also a dropped or coasted robot arm could collide with peripheral devices.

 **CAUTION** Do not turn OFF the robot controller's main power while rewriting the robot controller's internal information, such as a program and parameter. Turning OFF the robot controller's main power during automatic operation or program/parameter writing could break the internal information of the robot controller.

 **DANGER** Do not connect the Handy GOT when using the GOT direct connection function of this product. Failure to observe this may result in property damage or bodily injury because the Handy GOT can automatically operate the robot regardless of whether the operation rights are enabled or not.

 **DANGER** Do not connect the Handy GOT to a programmable controller when using an iQ Platform compatible product with the CR750-Q/CR751-Q controller. Failure to observe this may result in property damage or bodily injury because the Handy GOT can automatically operate the robot regardless of whether the operation rights are enabled or not.

 **DANGER** Do not remove the SSCNET III cable while power is supplied to the multiple CPU system or the servo amplifier. Do not look directly at light emitted from the tip of SSCNET III connectors or SSCNET III cables of the Motion CPU or the servo amplifier. Eye discomfort may be felt if exposed to the light.  
(Reference: SSCNET III employs a Class 1 or equivalent light source as specified in JIS C 6802 and IEC60825-1 (domestic standards in Japan).)

 **DANGER** Do not remove the SSCNET III cable while power is supplied to the controller. Do not look directly at light emitted from the tip of SSCNET III connectors or SSCNET III cables. Eye discomfort may be felt if exposed to the light.  
(Reference: SSCNET III employs a Class 1 or equivalent light source as specified in JIS C 6802 and IEC60825-1 (domestic standards in Japan).)

**DANGER**

Attach the cap to the SSCNET III connector after disconnecting the SSCNET III cable. If the cap is not attached, dirt or dust may adhere to the connector pins, resulting in deterioration connector properties, and leading to malfunction.

**CAUTION**

Make sure there are no mistakes in the wiring. Connecting differently to the way specified in the manual can result in errors, such as the emergency stop not being released. In order to prevent errors occurring, please be sure to check that all functions (such as the teaching box emergency stop, customer emergency stop, and door switch) are working properly after the wiring setup is completed.

**CAUTION**

Use the network equipments (personal computer, USB hub, LAN hub, etc) confirmed by manufacturer. The thing unsuitable for the FA environment (related with conformity, temperature or noise) exists in the equipments connected to USB. When using network equipment, measures against the noise, such as measures against EMI and the addition of the ferrite core, may be necessary. Please fully confirm the operation by customer. Guarantee and maintenance of the equipment on the market (usual office automation equipment) cannot be performed.

**CAUTION**

To maintain the safety of the robot system against unauthorized access from external devices via the network, take appropriate measures. To maintain the safety against unauthorized access via the Internet, take measures such as installing a firewall.

■ Revision History

Print Date	Instruction Manual No.	Revision content
2012-10-03	BFP-A8947	<ul style="list-style-type: none"> <li>• First print</li> </ul>
2015-12-10	BFP-A8947-A	<ul style="list-style-type: none"> <li>• The cover design of this manual was changed.</li> </ul>
2016-04-08	BFP-A8947-B	<ul style="list-style-type: none"> <li>• Application Examples were corrected. (Section 8.3.6 and 10)</li> <li>• Table 13-3 was modified.</li> <li>• Table 3-2: Force sense function specifications was modified and corrected.</li> <li>• Force sense interface unit outline drawings were changed.</li> <li>• Power supply specifications of the 24 VDC power supply was added.</li> <li>• The figures of the 24 VDC output cable and the 24 VDC input cable were changed.</li> <li>• Force sensor set 4F-FS001-W1000 was added.</li> <li>• Figures in “6.1 Force Sense Unit &lt;-&gt; Robot Controller were modified.</li> <li>• “6.4 Warm-up operation” was added.</li> <li>• The parameters were added. (FSMINCTL, FSLOFST)</li> <li>• “13.4 Q&amp;A” was added</li> <li>• “1.3 Select the Force Sensor” was added.</li> <li>• Force sensor calibration function was added.</li> <li>• Monitoring function for the resultant force and resultant moment.</li> <li>• Limited stiffness control function was added.</li> <li>• Section 5.5 was added.</li> </ul>
2018-11-30	BFP-A8947-C	<ul style="list-style-type: none"> <li>• Description of countermeasures against unauthorized access was added.</li> <li>• A spare fuse was added to the product configuration.</li> <li>• Contact information of the authorized representative was updated.</li> </ul>

## ■ Introduction

Thank you for purchasing a Mitsubishi Electric industrial robot. The "force sense function" uses force sensor information with 6 degrees of freedom to provide the robot with a sense of its own force. Using dedicated commands and status variables compatible with the robot program language (MELFA-BASICV) facilitates work requiring minute power adjustments and power detection that was not possible on past robots. Always read over this manual to gain a sufficient understanding of its content before using the "force sense function".

Please note that this instruction manual assumes that operators have an understanding of basic Mitsubishi Electric industrial robot operation and functionality. Refer to the separate "Instruction Manual, Detailed Explanations of Functions and Operations" for information on basic operation.

## ■ Notation used in this manual



### ***Danger***

Incorrect handling may result in imminent danger, leading to death or serious injury.



### ***Warning***

Incorrect handling may lead to death or serious injury.



### ***Caution***

Incorrect handling may result in property damage, or danger leading to impairment of the user.

#### Notice

- \*ONLY QUALIFIED SERVICE PERSONNEL MAY INSTALL OR SERVICE THE ROBOT SYSTEM.
- \*ANY PERSON WHO PROGRAM, TEACHES, OPERATE, MAINTENANCE OR REPAIRS THE ROBOT SYSTEM IS TRAINED AND DEMONSTRATES COMPETENCE TO SAFELY PERFORM THE ASSIGNED TASK.
- \*ENSURE COMPLIANCE WITH ALL LOCAL AND NATIONAL SAFETY AND ELECTRICAL CODES FOR THE INSTALLATION AND OPERATION OF THE ROBOT SYSTEM.

- No part of this manual may be reproduced by any means or in any form, without prior consent from Mitsubishi.
- The details of this manual are subject to change without notice.
- An effort has been made to make full descriptions in this manual. However, if any discrepancies or unclear points are found, please contact your dealer.
- The information contained in this document has been written to be accurate as much as possible. Please interpret that items not described in this document "cannot be performed." or "alarm may occur". Please contact your nearest dealer if you find any doubtful, wrong or skipped point.
- This specifications is original.



# [CONTENTS]

1 Using This Manual.....	1-1
1.1 Using This Manual .....	1-1
1.2 Terminology Used in This Instruction Manual .....	1-2
1.3 Select the Force Sensor .....	1-3
2 Work Flow .....	2-5
2.1 Flowchart.....	2-5
3 Force Sense Function System Specifications.....	3-6
3.1 What is the Force Sense Function?.....	3-6
3.2 System Configuration.....	3-7
3.3 Force Sense Function Specifications.....	3-8
3.4 Force Sense Interface Unit Specifications .....	3-10
3.4.1 Force Sense Interface Unit External Dimensions .....	3-10
3.4.2 Name of Each Force Sense Interface Unit Part .....	3-11
3.4.3 Force Sensor Connection Cable .....	3-11
3.5 24 VDC Power Supply Specifications .....	3-12
3.5.1 24 VDC Power Supply Outline Drawing .....	3-12
3.5.2 24 VDC Output Cable.....	3-13
3.5.3 24 VDC Input Cable.....	3-13
3.6 Force Sensor Specifications .....	3-14
3.6.1 Force Sensor External Dimensions.....	3-15
3.6.2 Sensor Attachment Adapter External Dimensions .....	3-16
3.7 Coordinate System Definition .....	3-18
3.7.1 Force Sense Coordinate System (Mechanical Interface).....	3-19
3.7.2 Force Sense Coordinate System (Tool) .....	3-19
3.7.3 Force Sense Coordinate System (XYZ).....	3-20
3.7.4 Force Sensor Coordinate System .....	3-21
4 Check Before Use .....	4-22
4.1 Product Check.....	4-22
4.1.1 Force Sensor Set 4F-FS001-W200.....	4-22
4.1.2 Force Sensor Set 4F-FS001-W1000.....	4-23
4.2 Software Versions .....	4-24
5 Attaching the Force Sensor .....	5-25
5.1 Attachment Adapter.....	5-25
5.2 Sensor Installation.....	5-25
5.3 Recommended Attachment Angle.....	5-26
5.4 Securing the force sensor cable .....	5-27
5.5 Tool installation.....	5-28
6 Device Connection, Wiring, and Settings .....	6-29
6.1 Force Sense Unit ↔ Robot Controller .....	6-29
6.2 Force Sense Interface Unit ↔ Force Sensor.....	6-32
6.3 Turning ON the Power .....	6-34
6.4 Warm Up Operation .....	6-34
6.5 Default Parameter Settings.....	6-35
6.5.1 Force Sense Interface Unit identification.....	6-36
6.5.2 Calibration .....	6-37
6.5.3 Force Sensor Tolerance .....	6-40
6.5.4 Force Sensor Control Offset Limit .....	6-41
6.5.5 Force Sensor Data Filter Setting .....	6-41
6.5.6 Force Sensor Minimum Control Force .....	6-41
7 Checking the Connection and Settings .....	7-42
7.1 Checking Force Sensor Data Communication.....	7-42
7.1.1 If Using R56TB/R57TB.....	7-42

7.1.2 If Using R32TB/R33TB .....	7-43
7.2 Checking the Force Sensor Attachment Coordinate System.....	7-44
8 Using the Force Sense Function (Programming) .....	8-45
8.1 Force Sense Control .....	8-46
8.1.1 Force Sense Enable/Disable Commands .....	8-48
8.1.2 Control Mode / Control characteristics .....	8-49
8.1.3 Offset Cancel Designation.....	8-59
8.1.4 Control characteristics Change Commands.....	8-60
8.1.5 Usage Example (Force Sense Control).....	8-62
8.2 Force Sense Detection .....	8-71
8.2.1 Mo Trigger .....	8-72
8.2.2 Force Detection Status .....	8-75
8.2.3 Data Latch .....	8-75
8.2.4 Data Referencing.....	8-75
8.2.5 Usage Example (Force Sense Detection).....	8-76
8.3 Force Sense log .....	8-81
8.3.1 Force Sense Log Function Specifications .....	8-81
8.3.2 Parameter Settings.....	8-83
8.3.3 Force Sense Log Data Acquisition .....	8-84
8.3.4 Force Sense Log Data Display (RT ToolBox2).....	8-85
8.3.5 Force Sense Log File FTP Transfer .....	8-90
8.3.6 Usage Example (Force Sense Log) .....	8-91
8.4 Gravity Offset Cancel Function .....	8-94
8.4.1 Estimated data.....	8-94
8.4.2 About Calibration Posture.....	8-94
8.4.3 Calibration Procedure.....	8-95
8.4.4 Usage Example (Force Sensor Calibration).....	8-102
9 Using the Force Sense Function (Teaching).....	9-104
9.1 Force Sense T/B .....	9-105
9.1.1 Force Sense Control (T/B) .....	9-105
9.1.2 Force Sense Monitor .....	9-109
9.1.3 Contact Detection .....	9-110
9.1.4 Usage Example (Force Sense Function T/B).....	9-111
9.2 Teaching Operation .....	9-115
9.2.1 Teaching Position Precautions .....	9-115
9.2.2 Usage Example (Teaching Operation) .....	9-119
9.3 Force Sense Function Screen .....	9-124
9.3.1 R56TB/R57TB .....	9-124
9.3.2 R32TB/R33TB .....	9-127
10 Application Examples .....	10-131
11 Language Specifications.....	11-135
11.1 Commands Relating to Force Sense Control Function.....	11-135
11.2 Status Variables Relating to Force Sense Control Function .....	11-143
11.3 Commands Relating to Force Sense Detection Function .....	11-153
11.4 Status Variables Relating Force Sense Detection Function.....	11-156
11.5 Commands Relating to Force Sense Log Function .....	11-169
11.6 Related Commands for Gravity Offset Cancel Function .....	11-172
11.7 Related Status Variables for Gravity Offset Cancel Function.....	11-175
11.8 Other Related Commands .....	11-179
11.9 Examples.....	11-183
12 Parameter Specifications.....	12-188
12.1 Force Sense Function Related Parameter List.....	12-188
12.2 RT ToolBox2 Force Sense Function Parameter Setting Screen.....	12-192
12.3 R56TB/R57TB Force Sense Function Parameter Setting Screen.....	12-195

13 Troubleshooting .....	13-198
13.1 Behavior when Force Sense Control Errors Occur.....	13-198
13.2 Force Sense Fuction Related Error List.....	13-198
13.3 Force Control Function Related Error Details .....	13-200
13.4 Q & A.....	13-206
14 Appendix.....	14-207
14.1 Control Status Transition .....	14-207



# 1 Using This Manual

## 1.1 Using This Manual

This manual is divided up in to the following sections, and describes how to use the force sense function, which employs a force sense interface and force sense sensor. Refer to the "Instruction Manual" provided with the robot controller for details on functionality and the operation methods for the standard robot controller.

**Table 1-1: Instruction Manual content**

Chapter	Title	Content
1	Using This Manual	Describes the makeup of this manual.
2	Work Flow	Describes the work required to construct a system employing a force sensor. Carry out the work as described.
3	Force Sense Function System Specifications	Describes the force sense function system specifications.
4	Check Before Use	Describes the product configuration and devices to be prepared. Check whether all the required products are present, and check the controller, T/B, and RT-ToolBox2 versions.
5	Force Sensor Attachment	Describes how to attach the force sensor to the robot. Pay heed to the precautions when using the robot with sensor attached.
6	Device Connection, Wiring, and Settings	Describes how to connect the respective devices.
7	Checking the Connection and Settings	Describes how to check that the sensor has been properly attached, that devices have been properly connected, and that all settings have been specified correctly. Always check these items before using the force sense function.
8	Using the Force Sense Function (Programming)	Describes how to use (programming method) the force sense function.
9	Using the Force Sense Function (Teaching)	Describes how to use (teaching method) the force sense function.
10	Application Examples	Describes application examples using the force sense function.
11	Language Specifications	Describes detailed MELFA-BASIC language specifications relating to the force sense function.
12	Parameter Specifications	Describes detailed parameter specifications relating to the force sense function.
13	Troubleshooting	Describes the details of and remedies for errors relating to the force sense function.

## 1.2 Terminology Used in This Instruction Manual

The following is a list of terminology used in this manual.

**Table 1-2: Description of Terminology**

	Content
Force sense function	This is the name of the robot control function using a force sensor. It consists of force sense control, force sense detection, and force sense log functions.
Force sense control	This function uses real-time information from the force sense function to control robot softness and the amount of force applied to workpieces.
Force sense detection	This function detects force sensor information, performs interrupt processing, and retains force sense data and robot position data when interrupts occur.
Force sense log	This function obtains and displays force sensor and robot position information.
Force control	This is a control method used to control robot force. Controls robot force while offsetting position in order to obtain the specified reaction force. This is used when pushing with constant force.
Stiffness control/limited stiffness control	This is a robot control method used to control robot stiffness. Controls the robot as though there is a spring on the robot hand flange surface. This method is used for copying around workpieces and assembling flexible objects. The limited stiffness control can restrict the force of the robot.
Force sensor	This sensor detects force and moment.
Force sense I/F unit	This unit takes in sensor information obtained from the force sensor and passes it to the robot controller.

### 1.3 Select the Force Sensor

Selection flow of force sensor is indicated on below. Confirm the selection result here and the force sensor specification of Chapter 3.6 , and please decide about the force sensor you use.

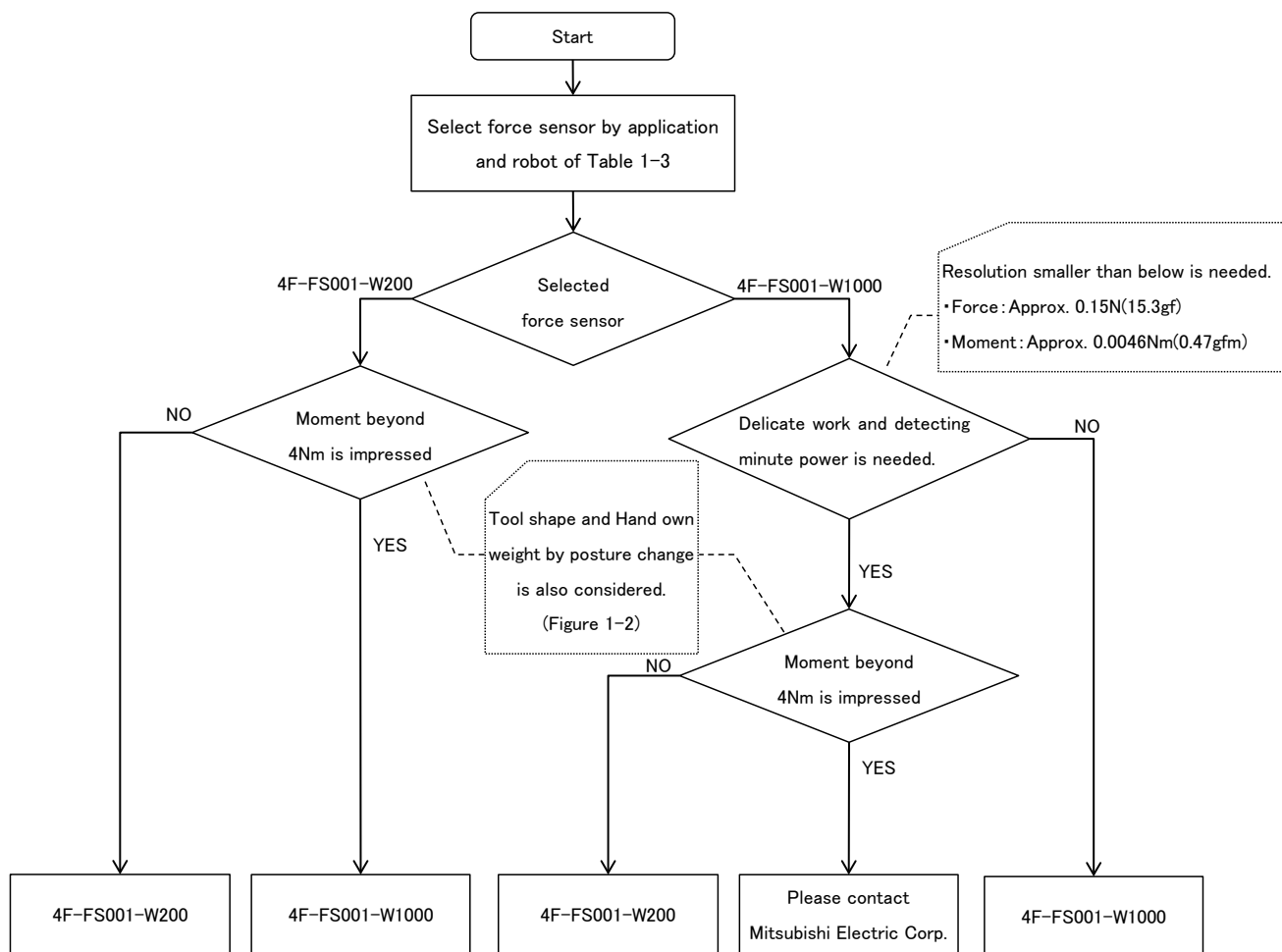

Fig. 1-1: Selection flow of force sensor

Table 1-3: First selection of force sensor

Application	Robot								
	RV-F Series					RH-F Series			
	RV-2F	RV-4F	RV-7F	RV-13F	RV-20F	RH-3F	RH-6F	RH-12F	RH-20F
Close tolerance fit	4F-FS001-W200		4F-FS001-W1000 or			4F-FS001-W200			
Phase focusing									
Parts assembly									
Test(Pressed/Pull-out)									
Inset			4F-FS001-W200 (Upward and downward limited)						
Deburr/Polishing	4F-FS001-W1000								

\*1: If you want to use the force sensor with the RV-35/50/70F robot, please contact Mitsubishi Electric Corporation.

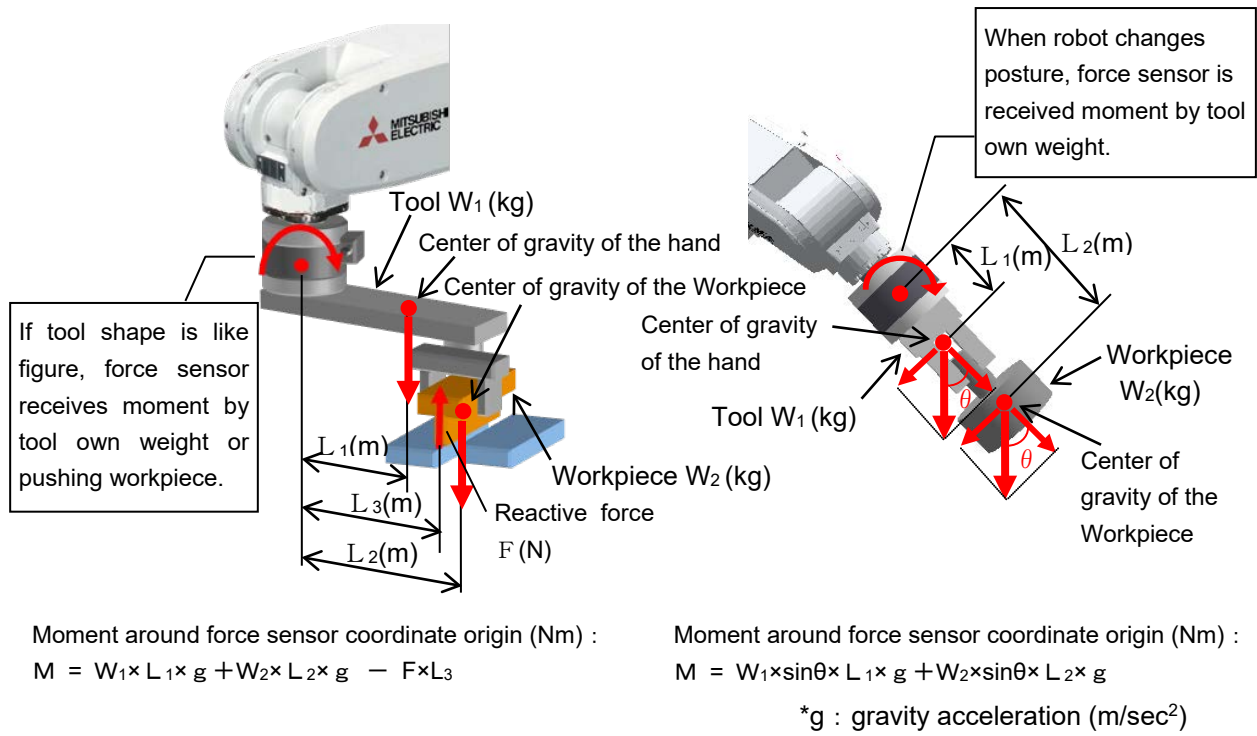

Fig. 1-2: Moment by the tool shape and a posture change



## 2 Work Flow

The work required to construct a system employing a force sensor is shown below. Refer to the following work flow and carry out the work as described.

### 2.1 Flowchart

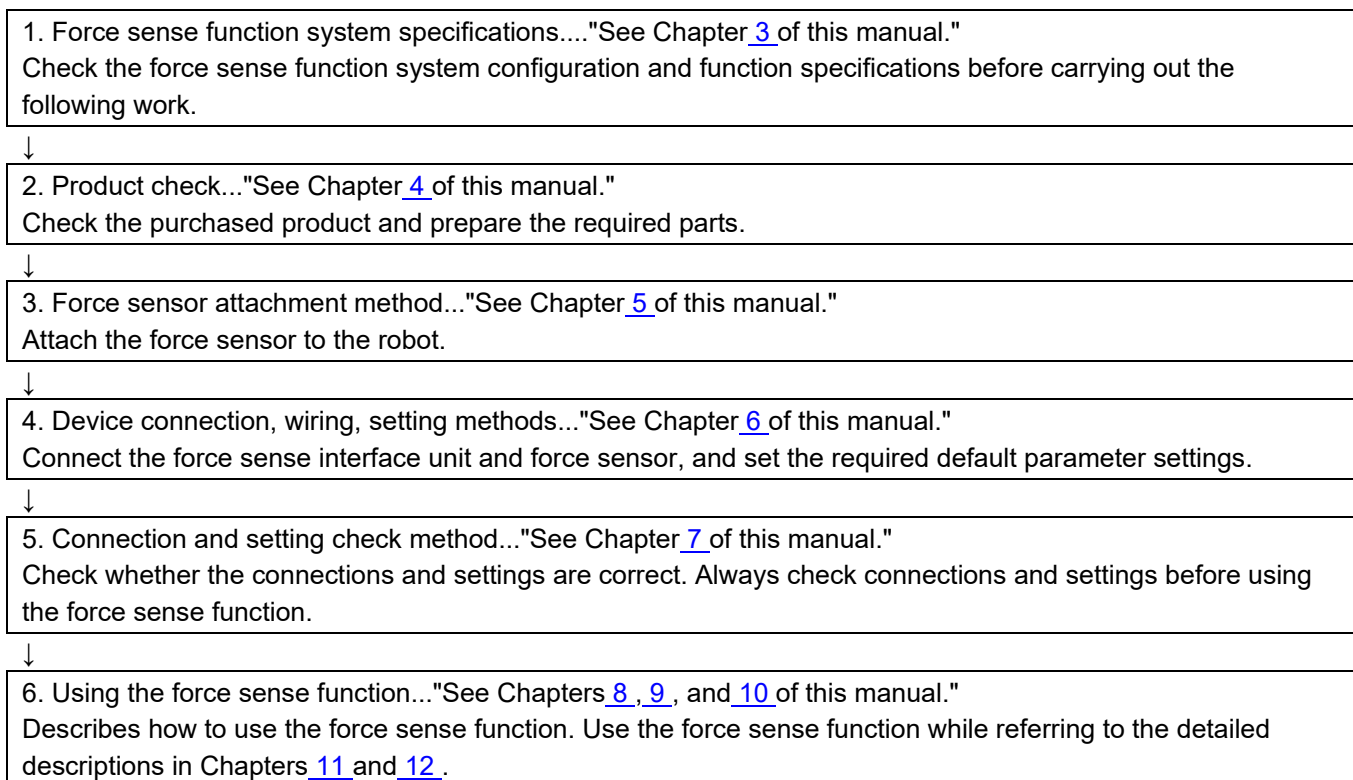

## 3 Force Sense Function System Specifications

### 3.1 What is the Force Sense Function?

The "force sense function" uses force sensor information with 6 degrees of freedom to provide the robot with a sense of its own force. Using dedicated commands and status variables compatible with the robot program language (MELFA-BASIC V) facilitates work requiring minute power adjustments and power detection that was not possible on past robots.

<Main features>

- (1) Robots can be controlled softly and operated while copying applicable workpieces.
- (2) Robots can be operated while pushing in the desired direction with a fixed amount of force.
- (3) Robot softness and contact detection conditions can be changed during movement.
- (4) Contact status can be detected and interrupt processing performed.
- (5) Position information and force information at the time of contact can be performed.
- (6) Force data synchronized with position data can be saved as log data.
- (7) Log data can be displayed in a graph using RT ToolBox2.
- (8) Log data files can be transferred to an FTP server.

### 3.2 System Configuration

The device configuration required to use the force sense function is shown below.

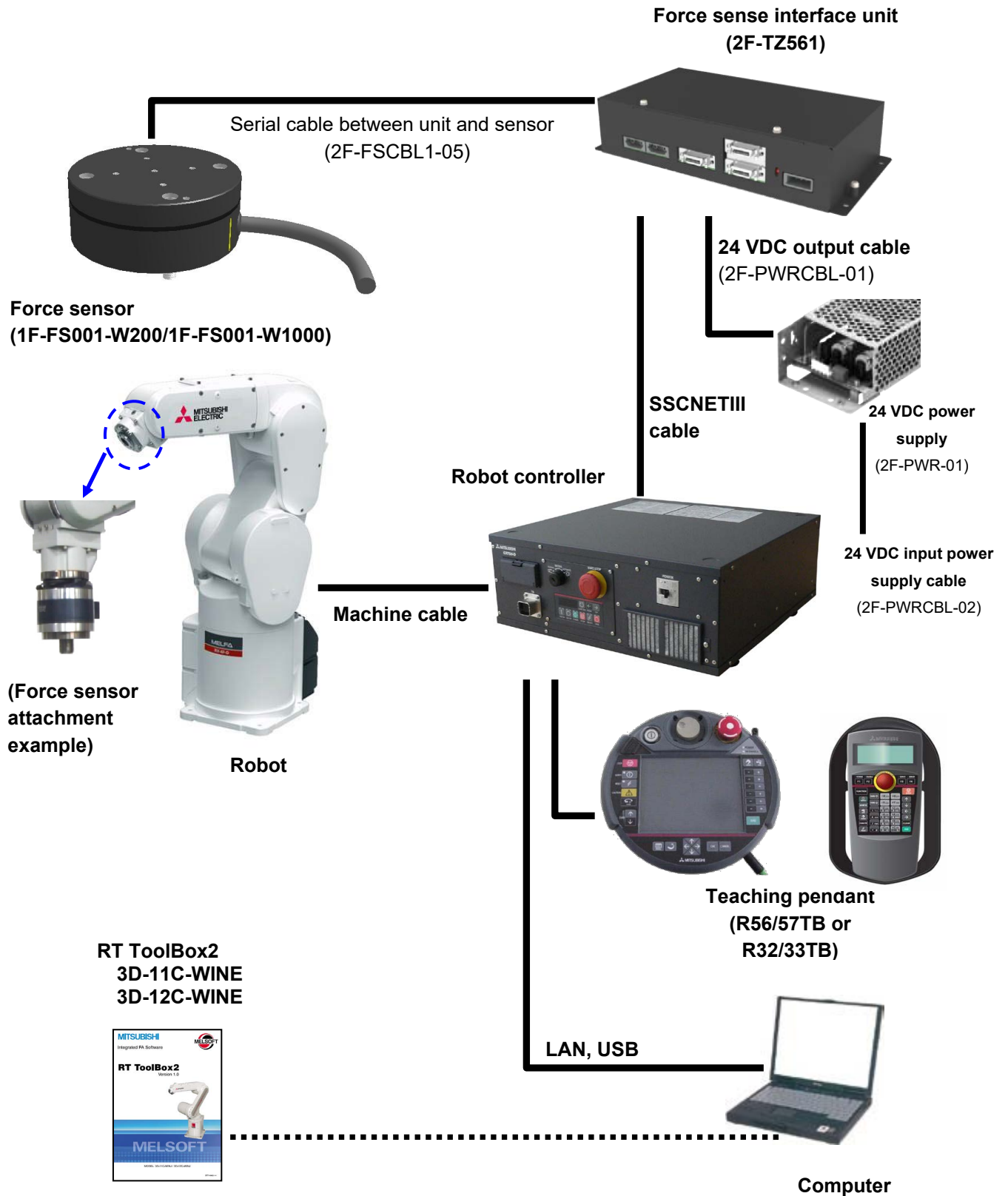

Fig. 3-1: Force sense function system configuration drawing

### 3.3 Force Sense Function Specifications

The force sense function specifications are as follows.

**Table 3-1: Force sense function specifications**

Item		Function Details		Remarks
Applicable robot		RV-F Series / RH-F Series		(*1)
Robot program language		MELFA-BASIC V (with dedicated force sense function commands)		
Controller	Force sense control	Stiffness control	Function used to control robot softly (Sets stiffness coefficients, damping coefficients.)	
		Limited stiffness control	Function used to control robot softly (Sets stiffness coefficients, damping coefficients.) This function can restrict the force of the robot.	This function can be used with controller version R6h/S6h or later.
		Force control	This function controls the robot while pushing with specified force.	
		Control characteristics change	This function changes the control characteristics of force control and stiffness control during robot movement.	
	Force sense detection	Interrupt execution	Interrupt processing can be performed using the status at the point the specified force and moment are exceeded.	
		Data latch	This function obtains the force sensor and robot position at the time of contact.	
		Data referencing	This function displays force sensor data and retains maximum values.	
	Force sense log	Synchronization data	This function obtains force sensor information synchronized with position information as log data.	
		Start/end triggers	Logging start and end commands can be specified in the robot program.	
		FTP transfer	This function transfers obtained log files to an FTP server.	
	Gravity offset cancel		Gravity offset cancel is a function that the offset cancel in response to a change in the direction of gravity applied to the force sensor by hand load at the time of posture change. To use this function, it is necessary to estimate the bias value of the force sensor, position of the center of gravity and the mass of hand load by the force calibration.	This function can be used with controller version R6h/S6h or later. Corresponding robot of this function has become RV-F series.
	R32TB/R33TB	Force sense control (TB)	Enables/disables force sensor control and sets control conditions while jogging.	
		Force sense monitor	Displays sensor data and the force sense control setting status.	
Teaching position search		This function searches for the contact position.		
R56TB/R57TB	Force sense control (TB)	Enables/disables force sense control and sets control conditions while jogging.		
	Force sense monitor	Displays sensor data and the force sense control setting status.		
	Teaching position search	This function searches for the contact position.		
	Parameter setting screen	Dedicated force sense function parameter setting screen		

Item		Function Details	Remarks
RT ToolBox2	Waveform data display	Displays force sensor and position data.	
	Oscillograph	Displays the data which is retrieved from a force sensor.	This function can be used in the RT ToolBox software version 3.00A or later
	Parameter setting screen	Dedicated force sense function parameter setting screen	
	Force sensor calibration screen	Executes the force sensor calibration in this screen.	This function can be used in the RT ToolBox software version 3.00A or later

\*1: When using the FH-F series, you should purchase the sensor attachment adaptor separately.

### 3.4 Force Sense Interface Unit Specifications

The force sense interface unit specifications are as follows.

**Table 3-2: Force sense interface unit specifications**

Item		Unit	Specification Value	Remarks
Model		-	2F-TZ561	
Force sensor	No. of connected sensors	sensors	1	
Interface	RS-422	ch	1	For sensor connection
	SSCNET III	ch	2	For robot controller and additional axis amp connection
Power supply	Input voltage range	VDC	24 ±5%	There should be no momentary power interruptions or momentary voltage drops.
	Power consumption	W	25	Includes power supply capacity for force sensor unit.
External dimensions		mm	225(W) x 111(D) x 48(H)	Does not include protrusions.
Weight		kg	Approx. 0.8	
Construction			Panel installation, open type	IP20
Operating temperature range		°C	0 to 40	
Relative humidity		%RH	45 to 85	There should be no dew condensation.
Paint color			Dark gray	Munsell No.: 3.5PB3.2/0.8

#### 3.4.1 Force Sense Interface Unit External Dimensions

Outline drawings of the force sense interface unit are shown below.

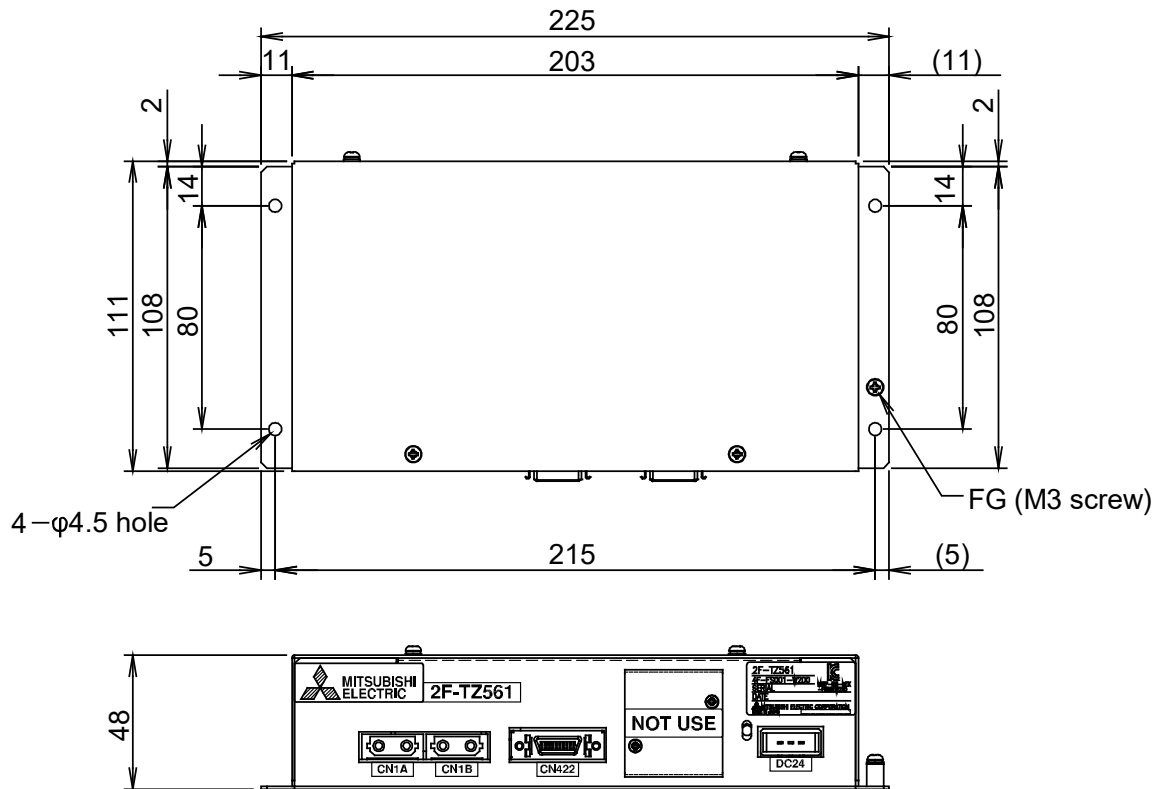

**Fig. 3-2: Force sense interface unit outline drawings**

### 3.4.2 Name of Each Force Sense Interface Unit Part

The name of each force sense interface unit part is as follows.

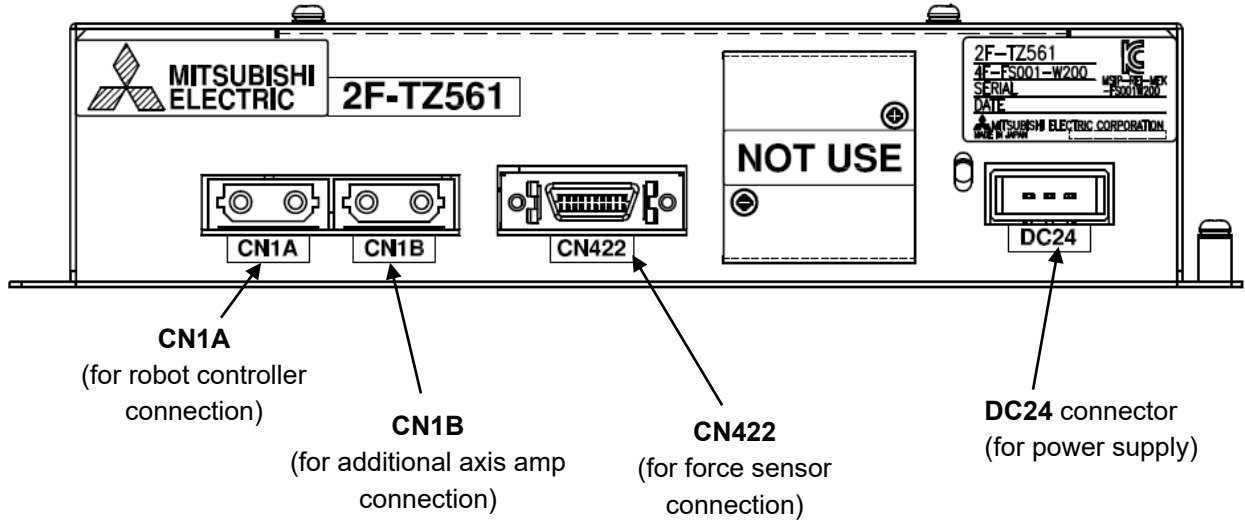

### 3.4.3 Force Sensor Connection Cable

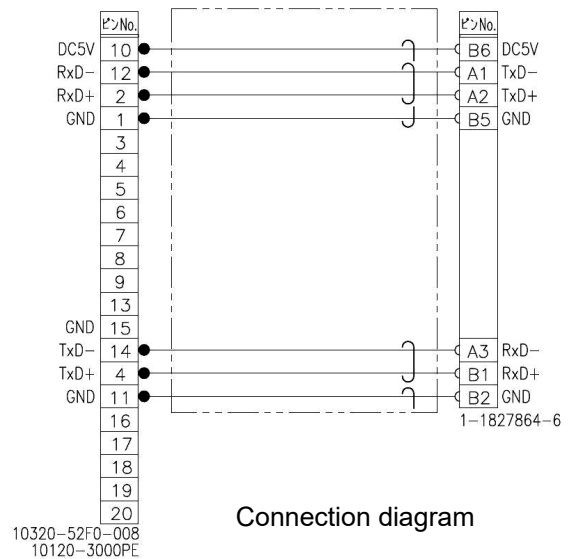
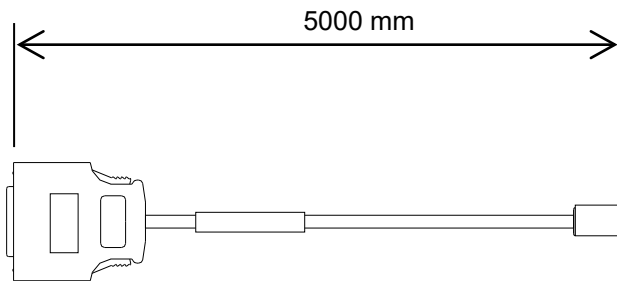

10320-52F0-008  
10120-3000PE

### 3.5 24 VDC Power Supply Specifications

The 24 VDC power supply specifications are as follows.

**Table 3-3: 24 VDC power supply specifications**

Item	Unit	Specification Value	Remarks	
Model	-	2F-PWR-01		
Input	Voltage	VAC	85 to 264	
	current	A	1.3 typ.	ACIN 100V
			0.7 typ.	ACIN 200V
Frequency	Hz	50 or 60 (47 to 63)		
Output	Rated voltage	VDC	24	
	Rated current	A	4.3	
	Voltage setting accuracy	VDC	23.00 to 25.00	
External dimensions	mm	72(W) x 185(D) x 45(H)		
Weight	g	480		
Construction		Panel installation, open type	IP20	
Operating temperature range	°C	-10 to 70		
Relative humidity	%RH	20 to 90	There should be no dew condensation.	

#### 3.5.1 24 VDC Power Supply Outline Drawing

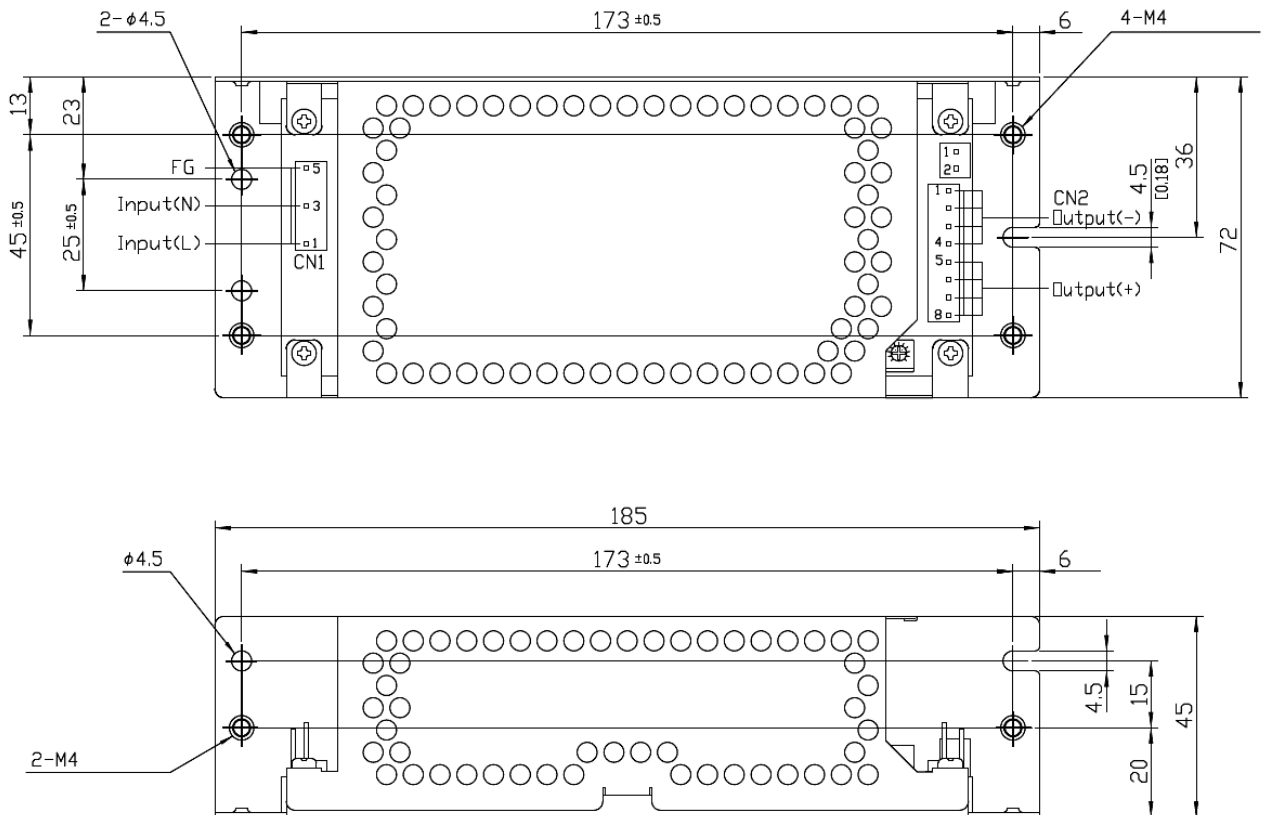

**Fig. 3-3: 24 VDC power supply outline drawing**



### 3.5.2 24 VDC Output Cable

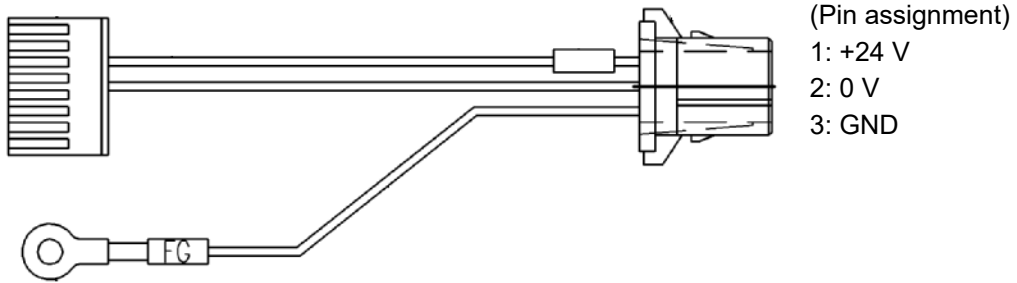

### 3.5.3 24 VDC Input Cable

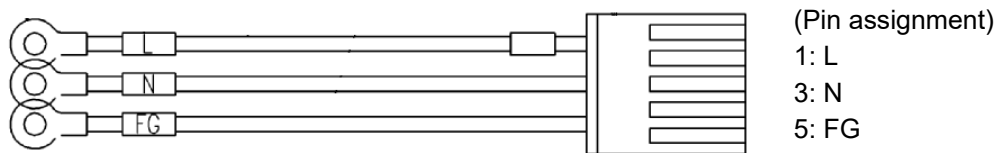

## 3.6 Force Sensor Specifications

The force sensor specifications are as follows.

**Table 3-4: Force sensor specifications**

Item		Unit	Specification Value		Remarks
Model		-	1F-FS001-W200	1F-FS001-W1000	
Rated load (*1)	Fx, Fy, Fz	N	200	1000	Be sure to set the value within the rated load to the FSLMTMX (force sensor permissible value) parameter.
	Mx, My, Mz	Nm	4	30	
Resolution	Fx, Fy, Fz	N	Approx. 0.03	Approx. 0.15	
	Mx, My, Mz	Nm	Approx. 0.0006	Approx. 0.0046	
Minimum control force (*2)	Fx, Fy, Fz	N	0.3		This value can be changed by the FSMINCTL (force sensor minimum control force) parameter. (Controller Ver. R6h/S6h or later)
	Mx, My, Mz	Nm	0.03		
Linearity		%FS	3		
Hysteresis		%FS	3		
Other axis sensitivity		%FS	5		
Zero temperature properties	Fx, Fy, Fz	%FS/°C	±0.2		
	Mx, My, Mz	%FS/°C	±0.2		
Consumption current		mA	200		
Output form		-	RS422		
Weight (sensor unit)		g	360	580	
External dimensions		mm	∅80 x 32.5	∅90 x 40	See outline drawing.
Material		-	Aluminum alloy		
Color		-	Black		
Operating environment	Temperature	°C	0 to 50		
	Humidity	%RH	95 or less		

\*1: When 1F-FS001-W200 is used with RV-7/13/20F robot, the moment beyond the moment rated load of the force sensor is applied if the tool/workpiece of the robot's maximum load mass is grasped and its hand posture is set vertically to the installation surface (the robot set on the floor). Use the force sensor with the hand posture at which the moment does not exceed the moment rated load (for example, with the hand posture facing downward).

\*2: Minimum value of force or moment for force sense control.



### Caution

When a load beyond the rated load is applied repeatedly, distortion occurs gradually inside the sensor. Therefore, the force does not be detected precisely. Use the force sensor with a load within the rated range.

### 3.6.1 Force Sensor External Dimensions

Outline drawings of the force sensor are shown below.

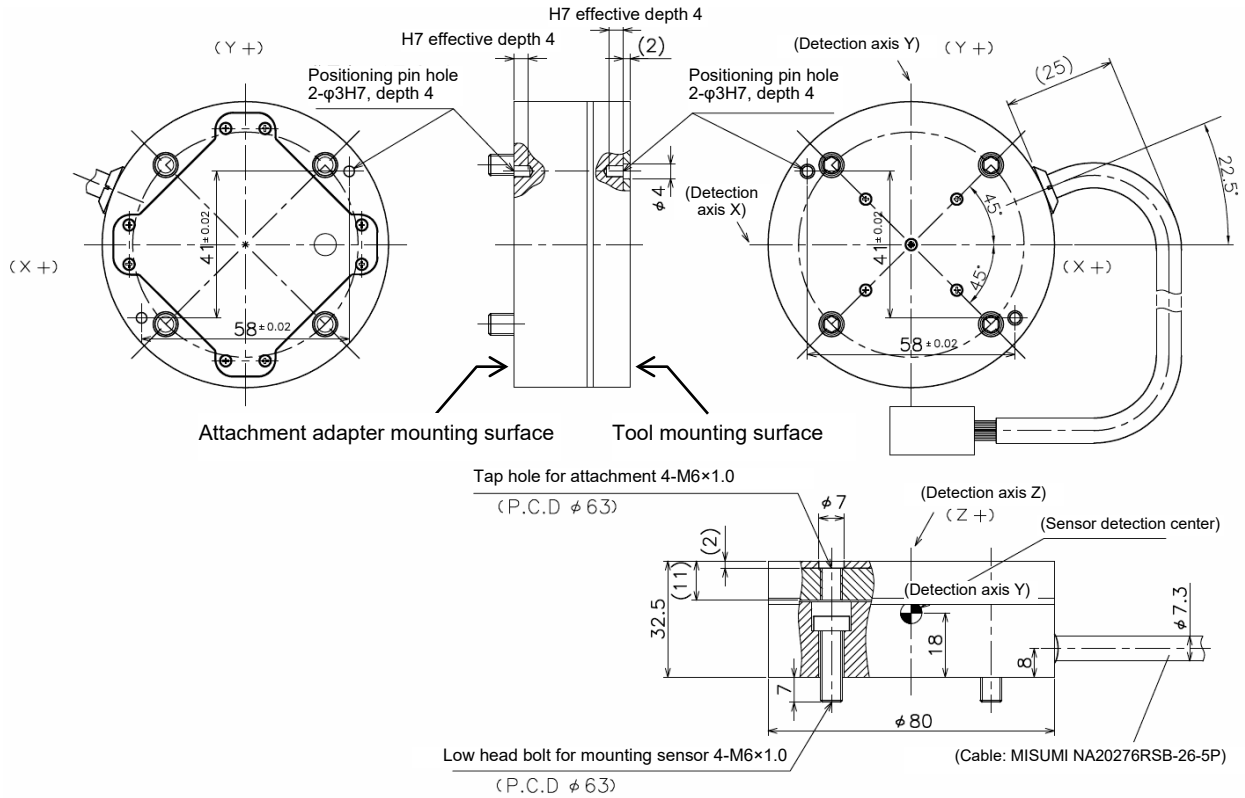

Fig. 3-4: Force sensor outline drawing (1F-FS001-W200)

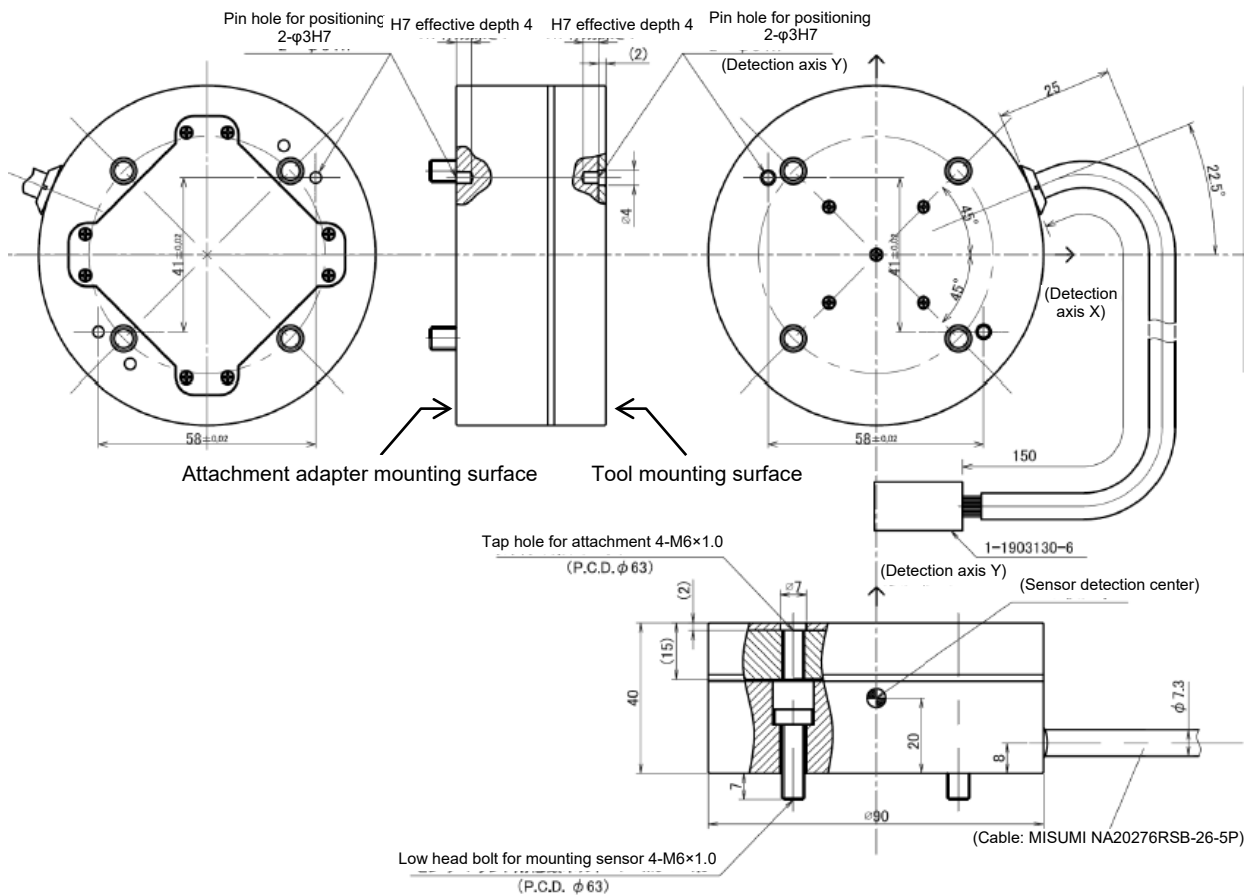

Fig. 3-5: Force sensor outline drawing (1F-FS001-W1000)

### 3.6.2 Sensor Attachment Adapter External Dimensions

Outline drawings of the sensor attachment adapter are shown below.

For 1F-FS001-W200

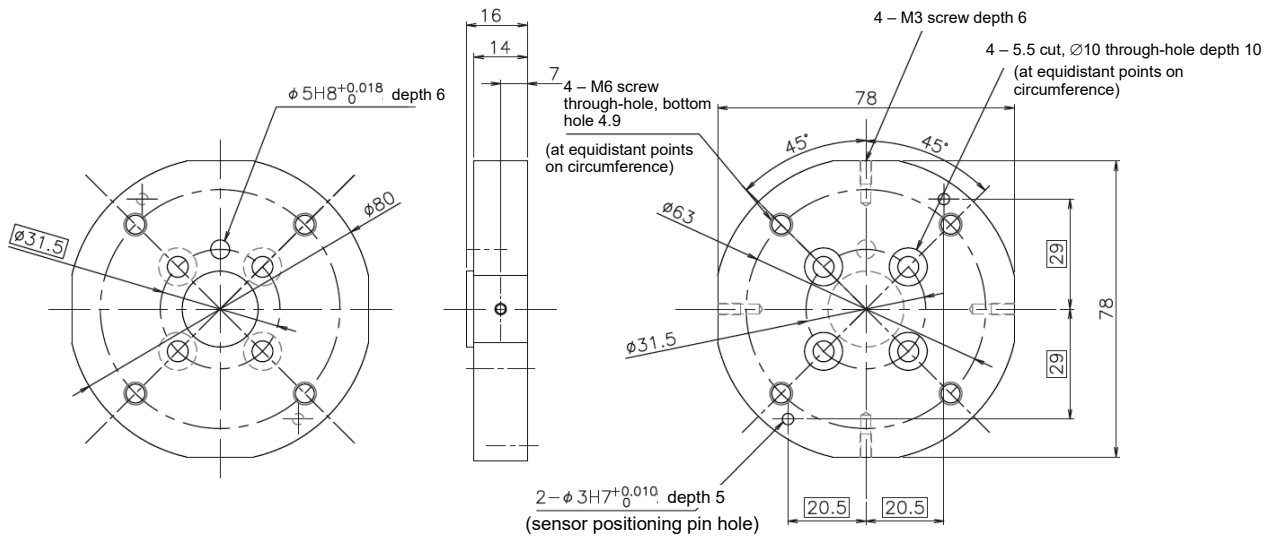

Fig. 3-6: Sensor attachment adapter outline drawings (for RV-2/4/7F)

For 1F-FS001-W1000

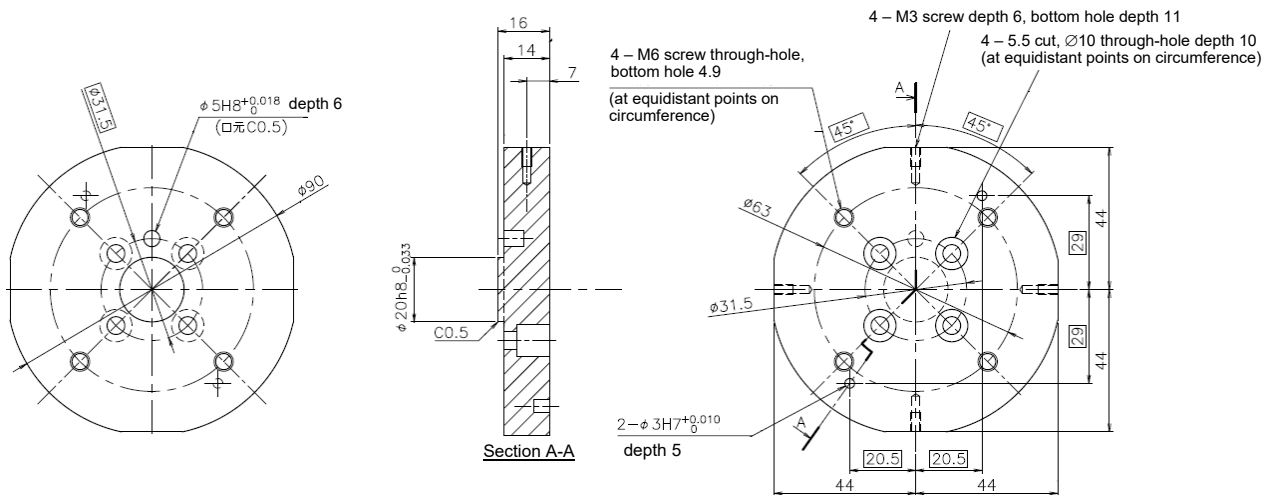

Fig. 3-7: Sensor attachment adapter outline drawings (for RV-2/4/7F)

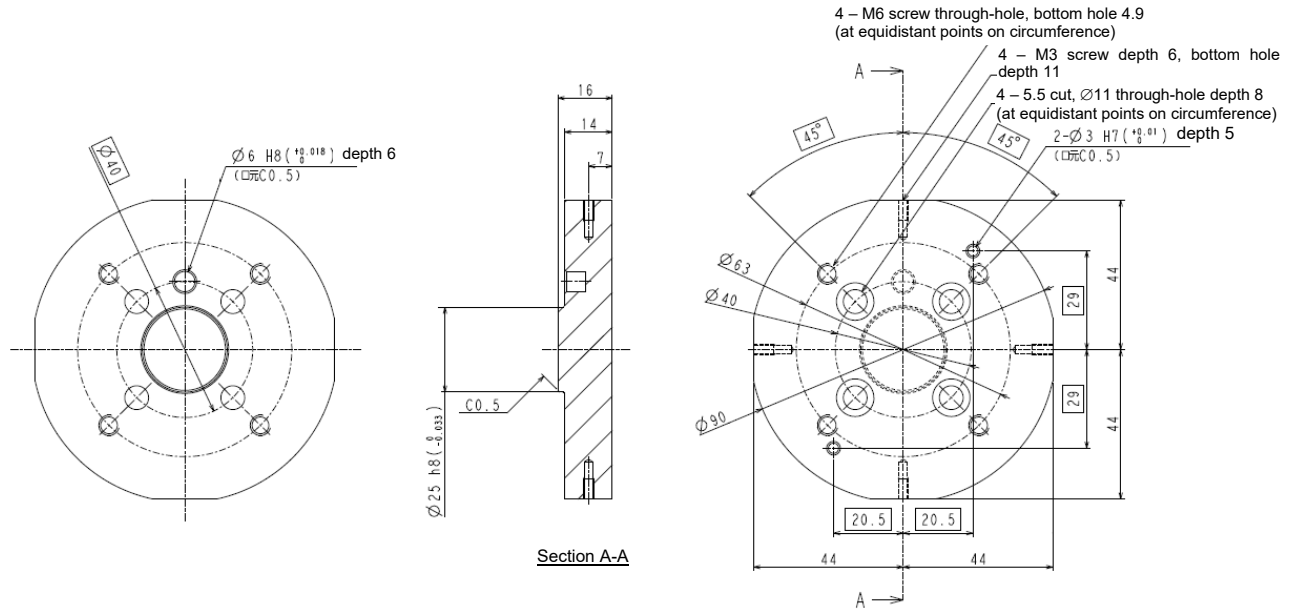

Fig. 3-8: Sensor attachment adapter outline drawings (for RV-13/20F)

## 3.7 Coordinate System Definition

The force and moment coordinate systems used with the force sense function are summarized in "Table 3-5".

**Table 3-5: Force sense coordinate system list**

Coordinate System Name	Description
Force sense coordinate system (mechanical interface)	Coordinate system that forms reference for calibration (See section <a href="#">6.5.2</a> for details on calibration.)
Force sense coordinate system (tool)	Coordinate system for force sense function (when tool selected)
Force sense coordinate system (XYZ)	Coordinate system for force sense function (when XYZ selected)
Force sensor coordinate system	Coordinate system for force sensor

A definition of each coordinate system is described below.

### 3.7.1 Force Sense Coordinate System (Mechanical Interface)

The force sense coordinate system (mechanical interface) is defined as follows.

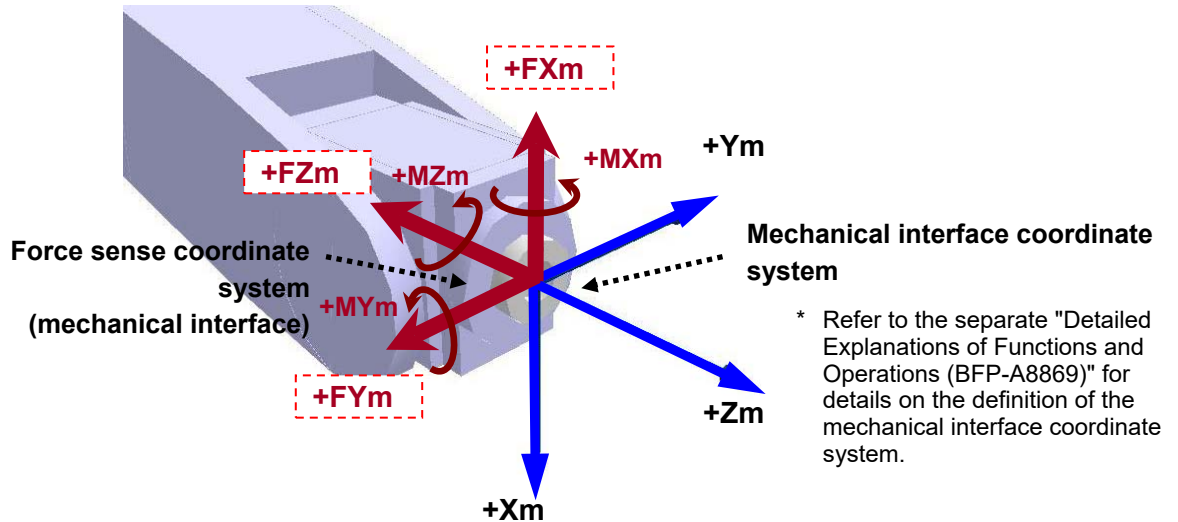

The force sense coordinate system (mechanical interface) is the plus direction coordinate system for the direction receiving the reaction force when the robot is moved in the mechanical interface coordinate system plus direction. The coordinate system origin point overlaps with that of the mechanical interface coordinate system. (In this coordinate system, the mechanical interface coordinate system symbols are reversed.)

### 3.7.2 Force Sense Coordinate System (Tool)

If the tool coordinate system is set, the force sense coordinate system (tool) is defined as follows based on the set tool coordinate system.

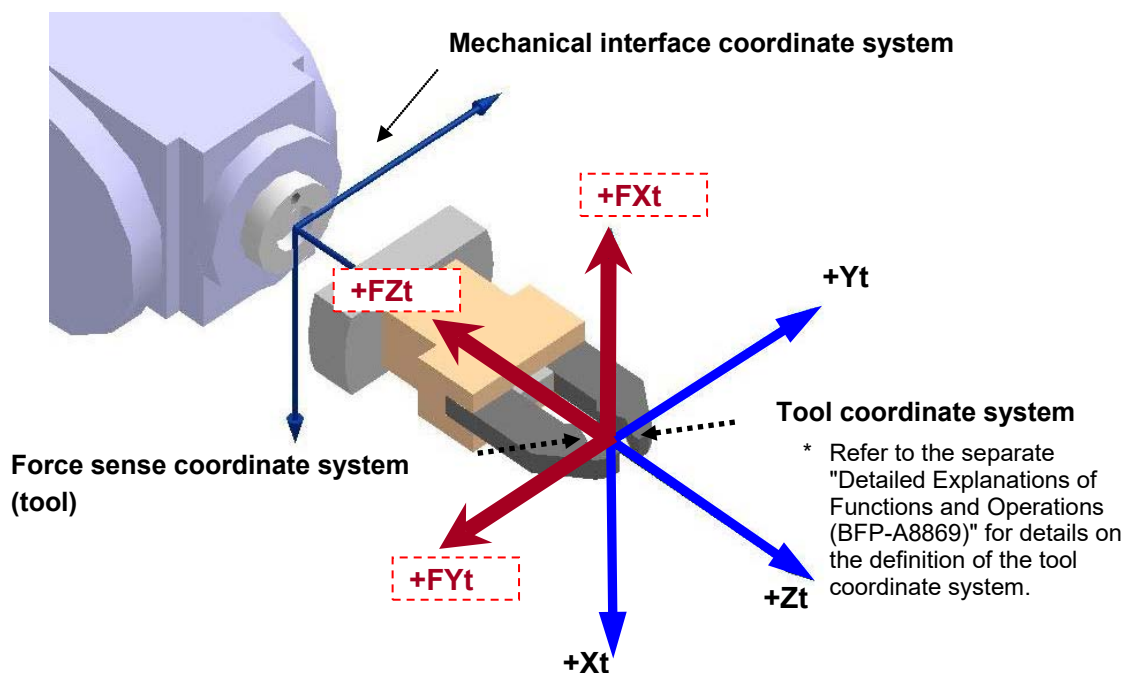

The force sense coordinate system (tool) is the plus direction coordinate system for the direction receiving the reaction force when the robot is moved in the tool coordinate system plus direction. The coordinate system origin point overlaps with that of the tool coordinate system. (In this coordinate system, the tool coordinate system symbols are reversed.)

### 3.7.3 Force Sense Coordinate System (XYZ)

The assumed force sense coordinate system (XYZ) used in force sense function processing is defined as follows.

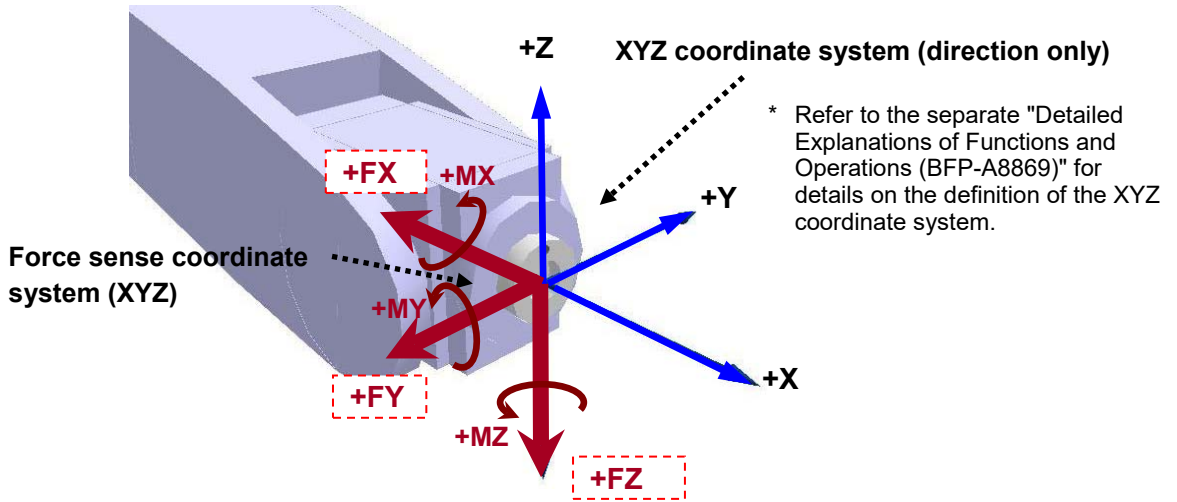

The force sense coordinate system (XYZ) is the plus direction coordinate system for the direction receiving the reaction force when the robot is moved in the XYZ coordinate system plus direction. The coordinate system origin point overlaps with that of the mechanical interface coordinate system.



### 3.7.4 Force Sensor Coordinate System

The force sensor coordinate system is defined as follows.

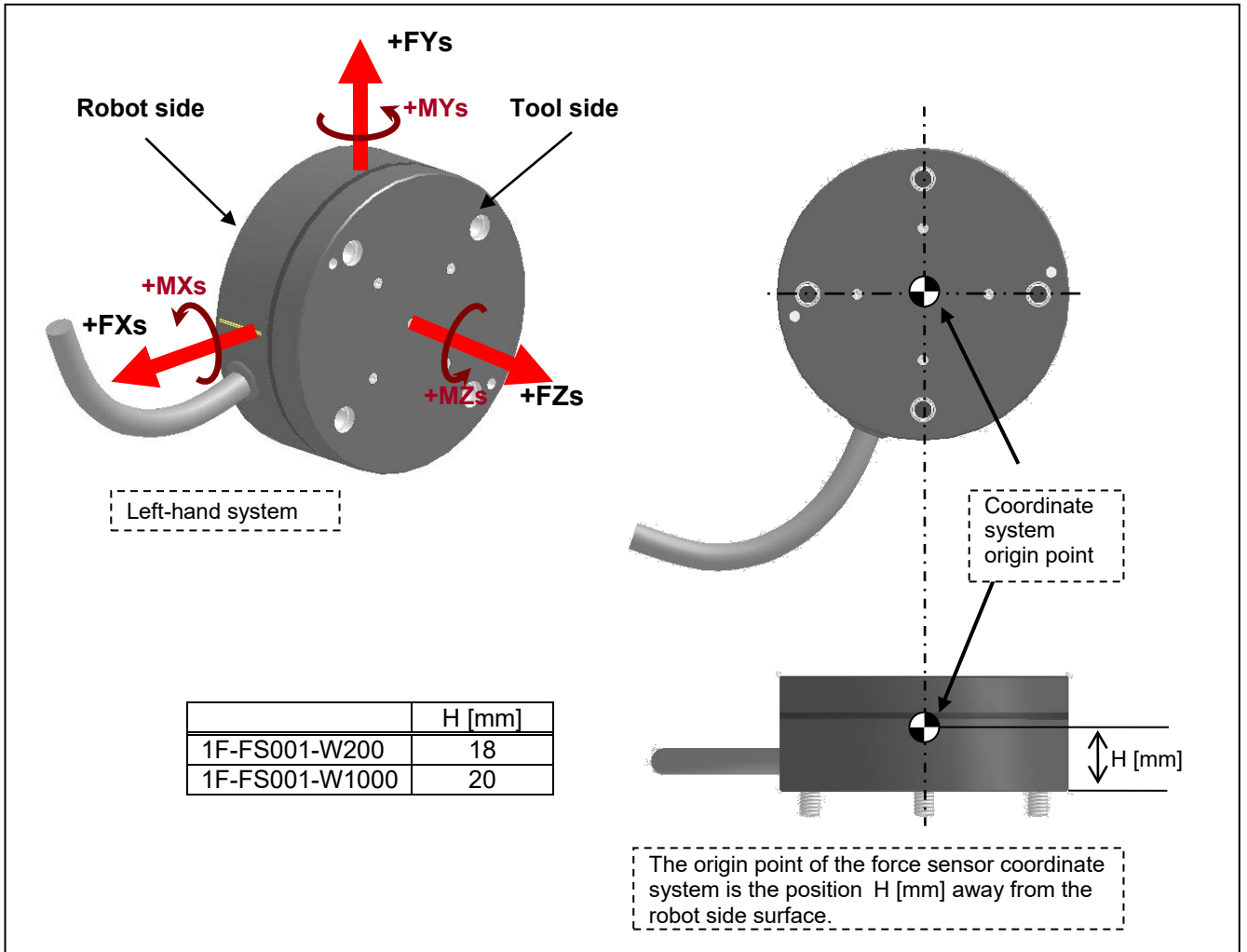

# 4 Check Before Use

## 4.1 Product Check

### 4.1.1 Force Sensor Set 4F-FS001-W200

The standard configuration of this product is as follows. Please check.

**Table 4-1: Force sensor set (4F-FS001-W200) product configuration list**

No.	Part Name	Model		Quantity	Remarks
<1>	Force sensor	4F-FS001-W200 (force sensor set)	1F-FS001-W200	1	
<2>	Force sense interface unit		2F-TZ561	1	
<3>	Sensor attachment adapter (RV-2/4/7F)		1F-FSFLG-01	1	
<4>	Adapter cable		1F-ADCBL-01	1	
<5>	24 VDC power supply		2F-PWR-01	1	
<6>	24 VDC power supply output cable (1 m)		2F-PWRCBL-01	1	
<7>	24 VDC power supply input cable (1 m)		2F-PWRCBL-02	1	
<8>	Serial cable between unit and sensor (2 m)		2F-FSCBL1-05	1	
<9>	SSCNET III cable (10 m)		MR-J3BUS10M	1	
<10>	CD-ROM		BFP-A8946	1	
<11>	Force sensor attachment accessories	-	1 set	- Hexagon socket bolt M5-12 (4) - Cylindrical pin φ 3 (2), φ 5 (1) - Cable tie (4) - Cable tie fixture (4) - P-type pan head screw M3-6 (4)	
<12>	Spare fuse	LM03	1		

Note) The numbers in the above table correspond to the numbers below.

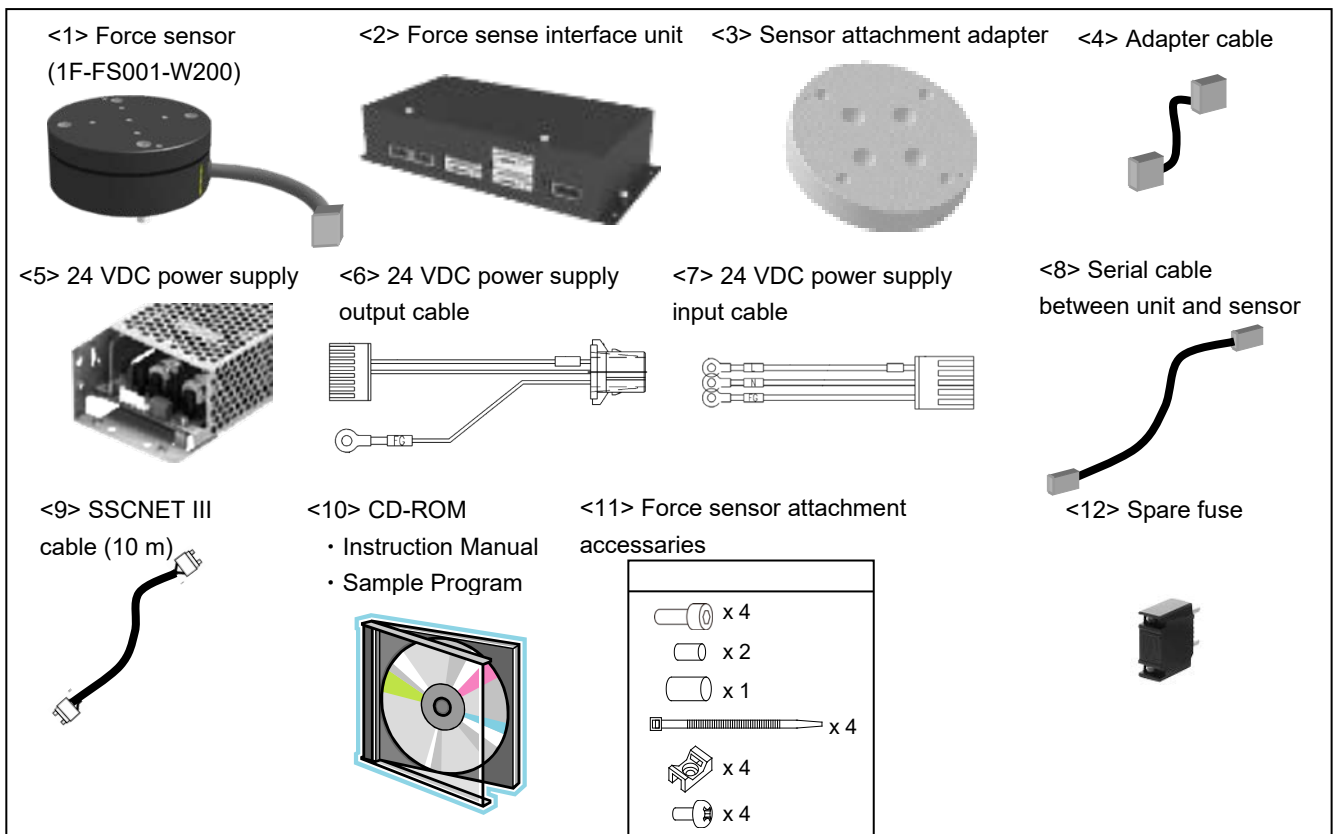

## 4.1.2 Force Sensor Set 4F-FS001-W1000

The standard configuration of this product is as follows. Please check.

**Table 4-2: Force sensor set (4F-FS001-W1000) product configuration list**

No.	Part Name	Model		Quantity	Remarks
<1>	Force sensor (*1)	4F-FS001-W1000 (force sensor set)	1F-FS001-W1000	1	
<2>	Force sense interface unit		2F-TZ561	1	
<3>	Adapter cable		1F-ADCBL-01	1	
<4>	24 VDC power supply		2F-PWR-01	1	
<5>	24 VDC power supply output cable (1 m)		2F-PWRCBL-01	1	
<6>	24 VDC power supply input cable (1 m)		2F-PWRCBL-02	1	
<7>	Serial cable between unit and sensor (5 m)		2F-FSCBL1-05	1	
<8>	SSCNET III cable (10 m)		MR-J3BUS10M	1	
<9>	CD-ROM		BFP-A8946	1	
<10>	Spare fuse		LM03	1	

\*1: The sensor attachment adapter is not supplied. You should purchase the sensor attachment adaptor separately. (See Table 4-3)

Note) The numbers in the above table correspond to the numbers below.

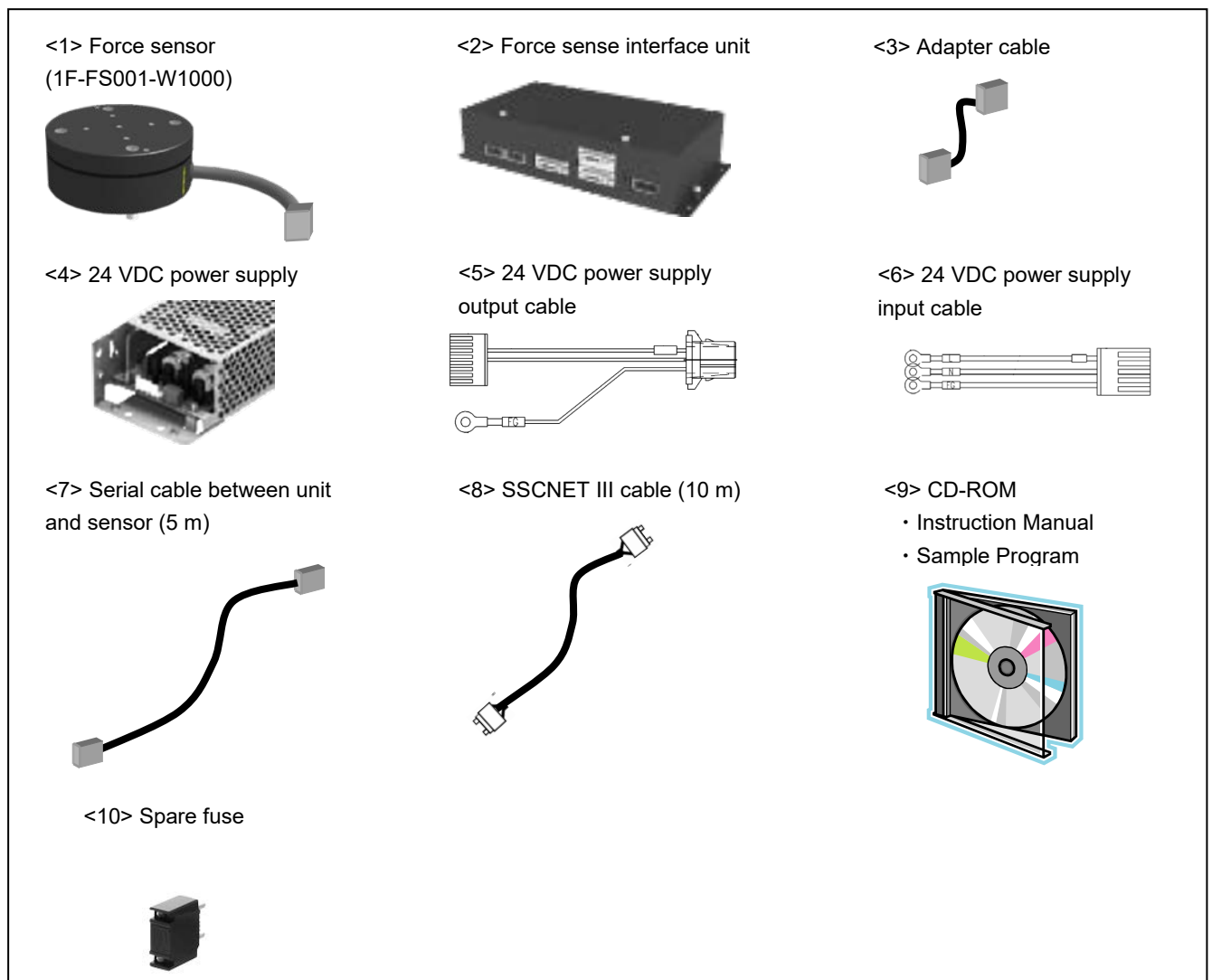

When using the force sensor set 4F-FS001-W1000, you should purchase the sensor attachment adapter set and the serial cable between unit and sensor (10 m) separately, according to your robot.

**Table 4-3: Additional items for force sensor set 4F-FS001-W1000**

Part Name	Model	Quantity	Remarks
Sensor attachment adapter (for RV-2/4/7F)	1F-FSFLGSET-01	1	<ul style="list-style-type: none"> <li>- Sensor attachment adapter 1F-FSFLG-02 (1)</li> <li>- Hexagon socket bolt M5-12 (4)</li> <li>- Cylindrical pin H7, <math>\phi</math> 3 x 8 (2)</li> <li>  H7, <math>\phi</math> 5 x 10 (1)</li> <li>- Cable tie (4)</li> <li>- Cable tie fixture (4)</li> <li>- P-type pan head screw M3-6 (4)</li> </ul>
Sensor attachment adapter (for RV-13/20F)	1F-FSFLGSET-02	1	<ul style="list-style-type: none"> <li>- Sensor attachment adapter 1F-FSFLG-03 (1)</li> <li>- Hexagon socket bolt M6-14 (4)</li> <li>- Cylindrical pin H7, <math>\phi</math> 3 x 8 (2)</li> <li>  H7, <math>\phi</math> 6 x 12 (1)</li> <li>- Cable tie (4)</li> <li>- Cable tie fixture (4)</li> <li>- P-type pan head screw M3-6 (4)</li> </ul>

## 4.2 Software Versions

All software must support the force sense function to facilitate its use. Check all versions prior to use.

### ■ Robot controller

Part Name	Model	Applicable Version	Remarks
Controller	CR750-Q/CR751-Q	Ver.R3m or later	Minimum control force can be changed in Ver.R6h or later.
	CR750-D/CR751-D	Ver.S3m or later	Minimum control force can be changed in Ver.S6h or later.

### ■ Teaching pendant

Part Name	Model	Applicable Version
Teaching pendant	R56TB/R57TB	Ver.3.0 or later
	R32TB/R33TB	Ver.1.7 or later

### ■ Support software

Part Name	Model	Applicable Version	Remarks
MELSOFT RT ToolBox2	3D-11C-WINJ 3D-11C-WINE	Ver.2.20W or later	Force sensor calibration screen can be used in Ver.3.60N or later.
MELSOFT RT ToolBox2 mini	3D-12C-WINJ 3D-12C-WINE	Ver.2.20W or later	

## 5 Attaching the Force Sensor

This Chapter describes how to attach the force sensor. The force sensor is a precision measuring instrument, and attaching it carelessly may lead to a drop in accuracy or fault. Always check the following before performing attachment.

Furthermore, it is necessary to correctly define the correlation between the sensor coordinate system and robot coordinate system. Refer to the recommended attachment method in section [5.3](#) for details on the sensor attachment angle.

### 5.1 Attachment Adapter

A dedicated "sensor attachment adapter" is required to secure the force sensor to the robot. As shown in the following diagram, attach the sensor attachment bracket to the robot mechanical interface before installing the force sensor.

<If preparing your own attachment adapter>

Refer to section [3.6.1](#) for details on the attachment shape at the sensor side. Furthermore, refer to the separate "Standard Specifications" for details on the shape of the robot mechanical interface.

(When using the FH-F series, you should purchase the sensor attachment adaptor separately.)

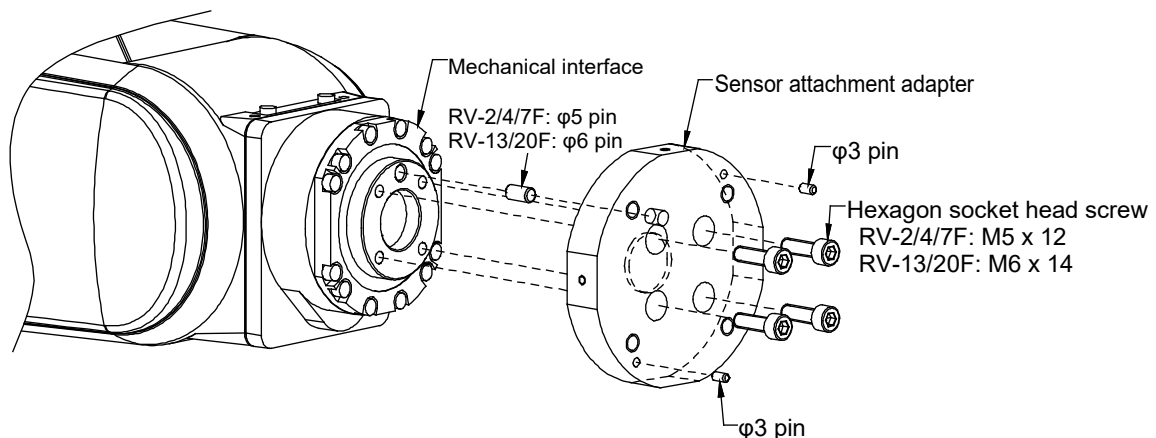

### 5.2 Sensor Installation

The force sensor is secured by tightening the bolts built in to the sensor from the bolt holes on the force sensor tool side. Tighten each bolt in order diagonally a little at a time to ensure even contact between the sensor installation surface and sensor attachment adapter. The sensor may be damaged if any of the bolts are overly tightened at one time, and therefore caution is advised. Always tighten each bolt a little at a time until the recommended torque value is reached (see below).

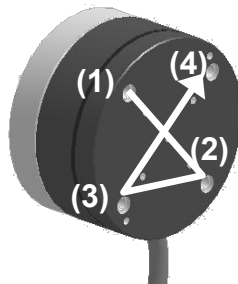

	Tightening torque [Nm]
1F-FS001-W200	6
1F-FS001-W1000	10



#### Caution

The sensor may be damaged if any of the bolts are overly tightened at one time, and therefore caution is advised.

## 5.3 Recommended Attachment Angle

The following attachment method is recommended to ensure easy calibration with the force sensor coordinate system and force sense coordinate system (mechanical interface) that forms the reference for the force sense function.

[Recommended attachment angle]

- Attach so that the sensor coordinate system +FXs direction is parallel with the mechanical interface coordinate system +Xm direction.

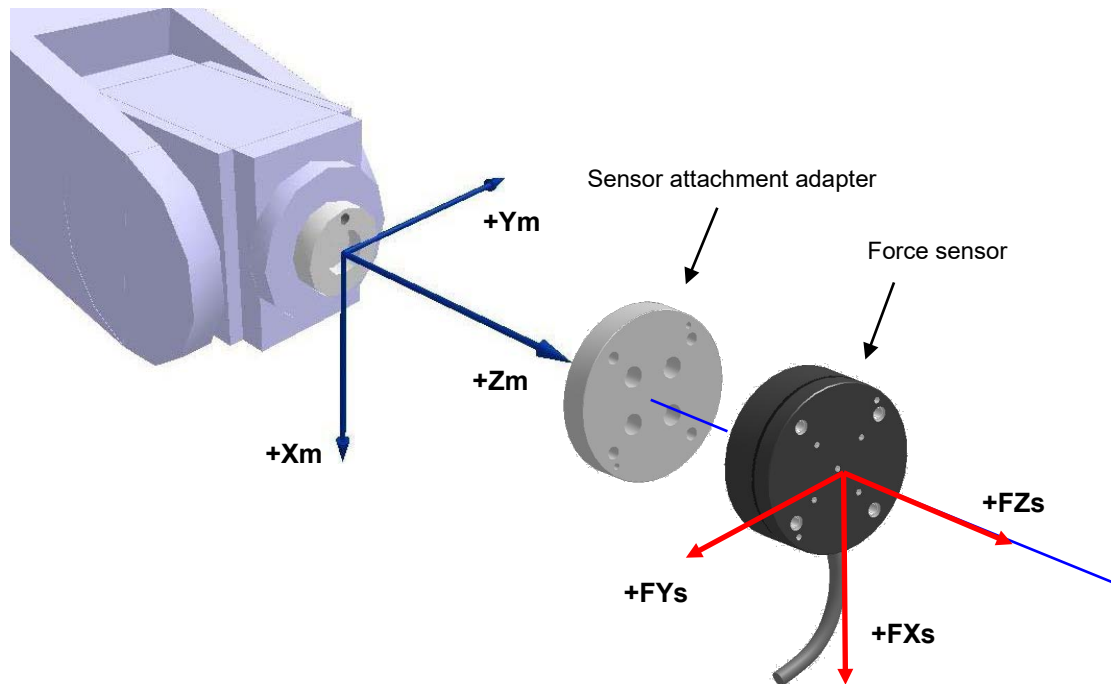

<Calibration>

To ensure proper functioning of the force sense function, it is necessary to correctly set the correlation between the force sensor coordinate system and force sense coordinate system (mechanical interface).

\* Refer to section [6.5.2](#) for details on the calibration method.

\* Refer to section [3.6](#) for details on the coordinate system definition.

## 5.4 Securing the force sensor cable

- 1) Mount a cable tie fixture (attachment) on the sensor attachment adapter with cable tie fixation screw (attachment).
- 2) Connect the force sensor cable to the hand cable or serial cable between unit and sensor.
- 3) Secure the cable with the cable tie and cable tie mount so that bend radius of the force sensor cable becomes 25 mm or more.

\* Ensure that the force sensor cable and connector are not subject to bending forces.

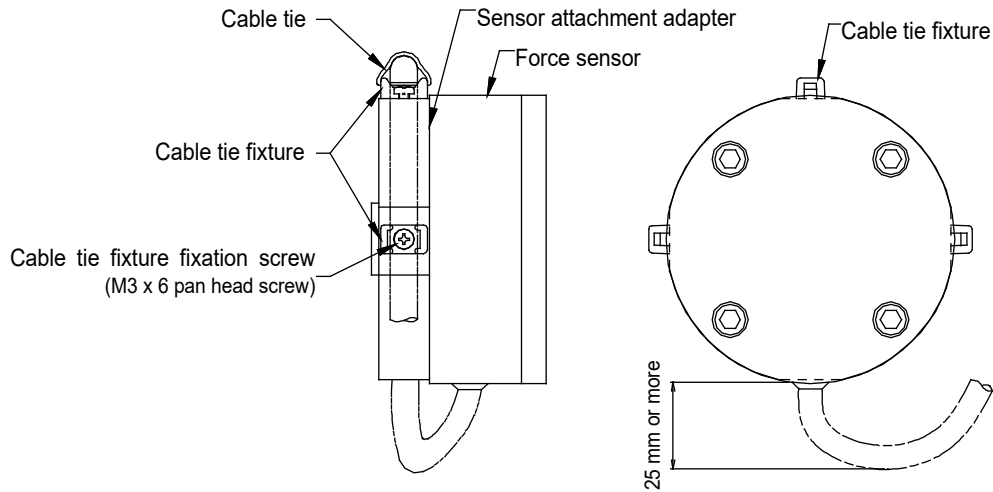

## 5.5 Tool installation

Use the bolt specified below when attaching a hand to the tool side of the force sensor. Tighten bolts little by little to ensure even contact.

	Nominal diameter	Tightening torque [Nm]	Engagement allowance [mm]
1F-FS001-W200	M6	6	8 to 11
1F-FS001-W1000	M6	10	10 to 15

Also, pay attention to the following points. Inappropriate installation will lead to obtaining inaccurate force data, adversely affecting performance of the force sense control.

- Ensure that the hand attachment surface is as flat as possible, and ensure sufficient stiffness to avoid any loss in force or moment.
- Do not attach the sensor in such a way that its attachment prevents movement of movable parts of the force sensor (as a result of inappropriate cable routing, etc.).

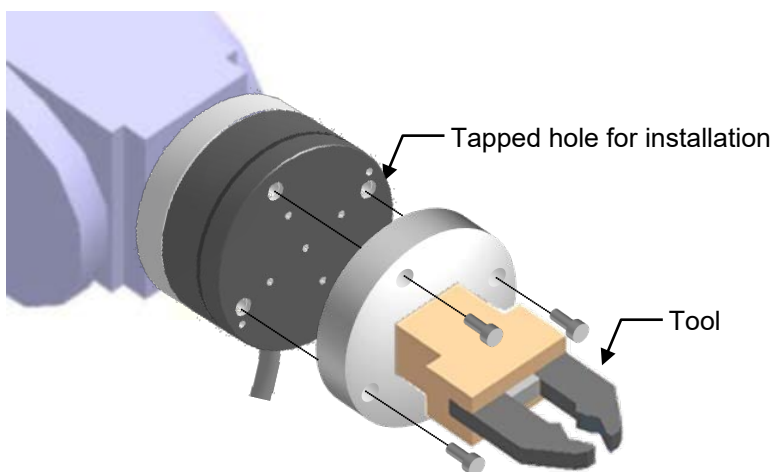

**⚠ Caution** For fixing the tool, do not apply the load equal to or beyond the rated load (especially the moment load) to the force sensor. When a load beyond the rated load is applied repeatedly, distortion occurs gradually inside the sensor. Therefore, the force does not be detected precisely.

**⚠ Caution** There are some hands equipped with air supply cables and/or power supply cables. Attaching them to the tool side of the force sensor will cause the cables to be swung, resulting in generation of a centrifugal force, which may adversely affect the accuracy of obtained force data. The accuracy of the data may also be affected by the weight of the cables. Take appropriate measures, such as fixing the cables to the sensor attachment adapter.



# 6 Device Connection, Wiring, and Settings

This Chapter describes "force sensor", "force sense interface unit", and "robot controller" connection, as well as default parameter settings.

## 6.1 Force Sense Unit ↔ Robot Controller

Connect the force sense interface unit and robot controller as shown below.

<CR750-D series>

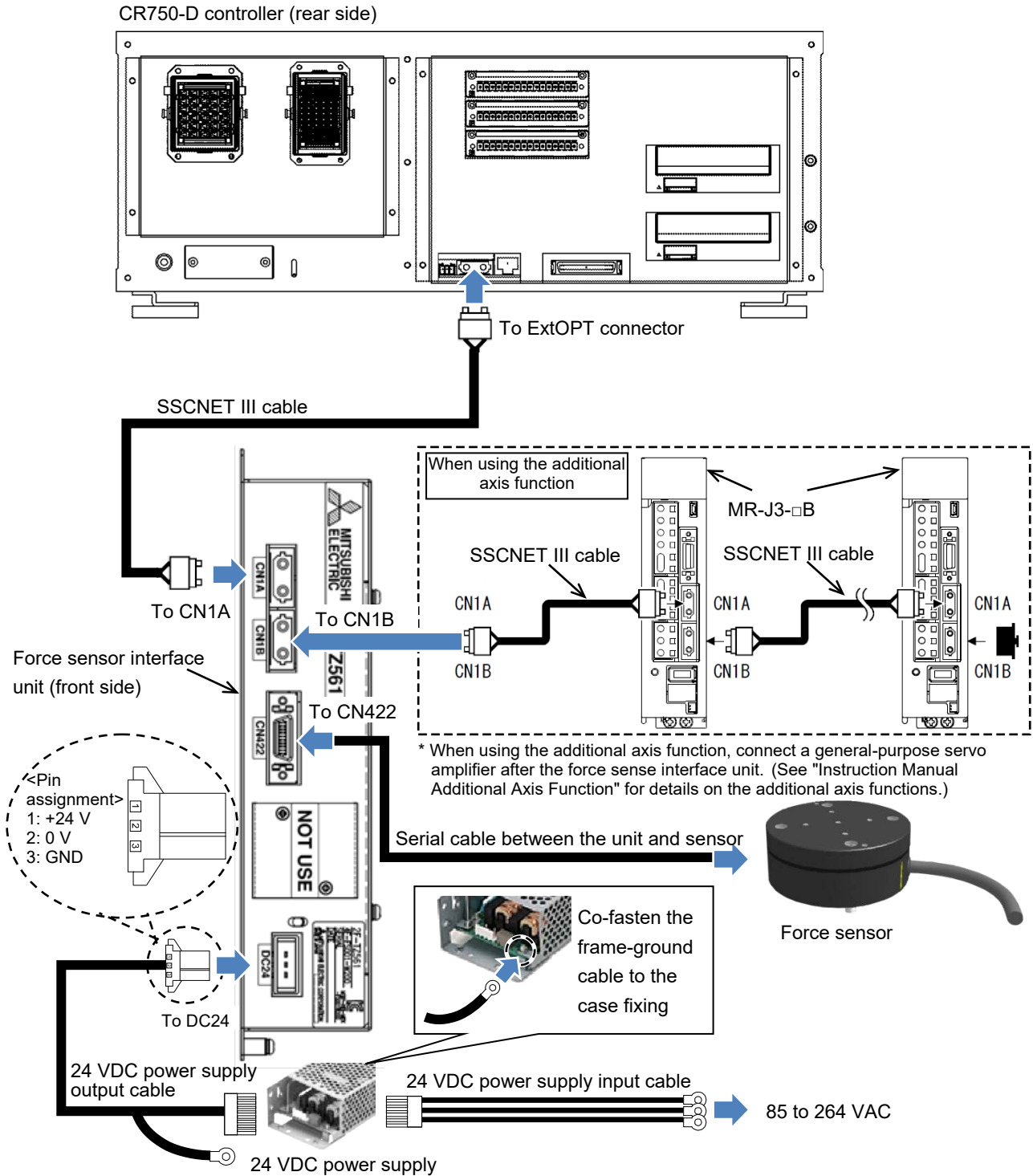

<CR751-D series>

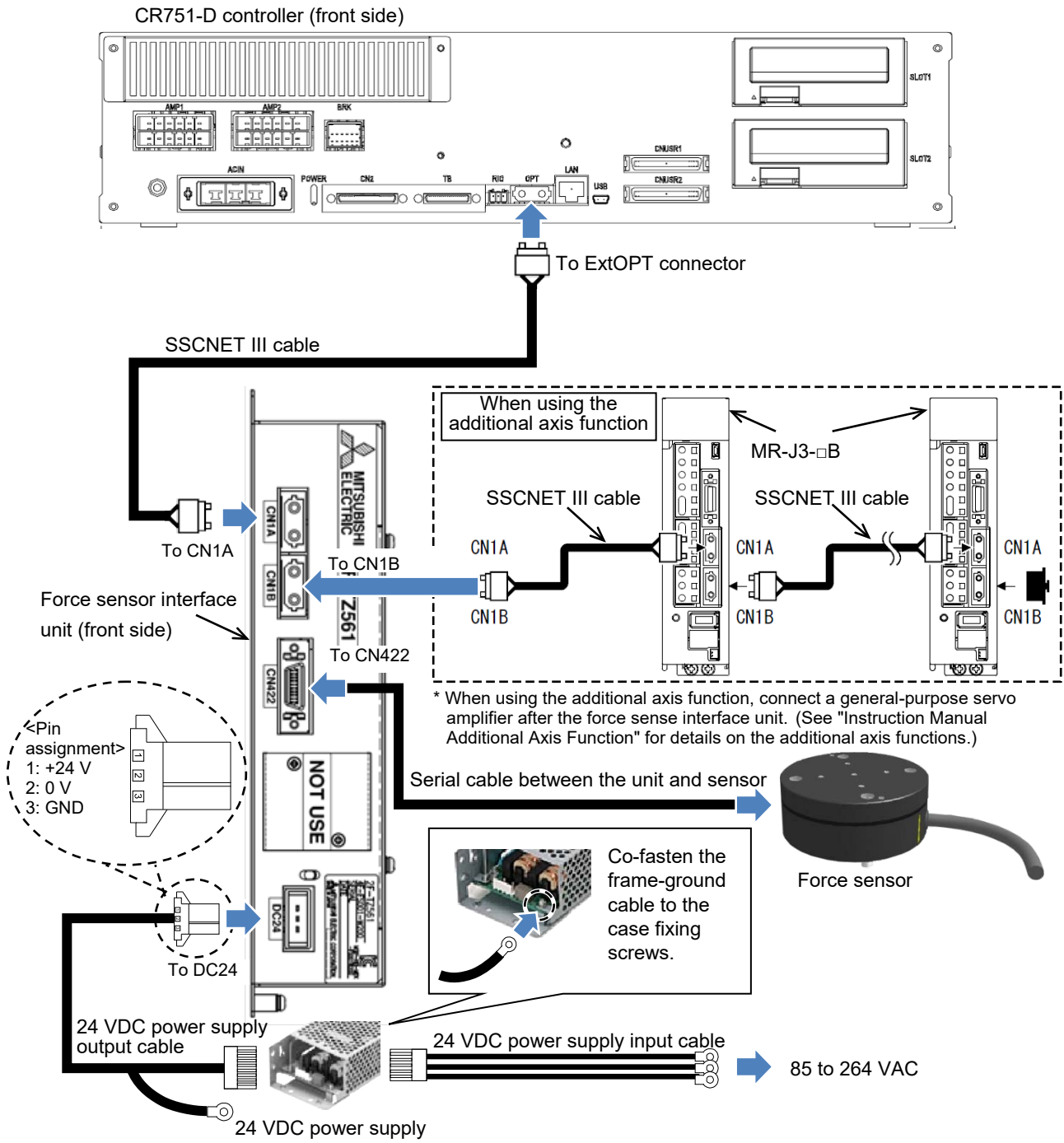

<CR750-Q/CR751-Q series>

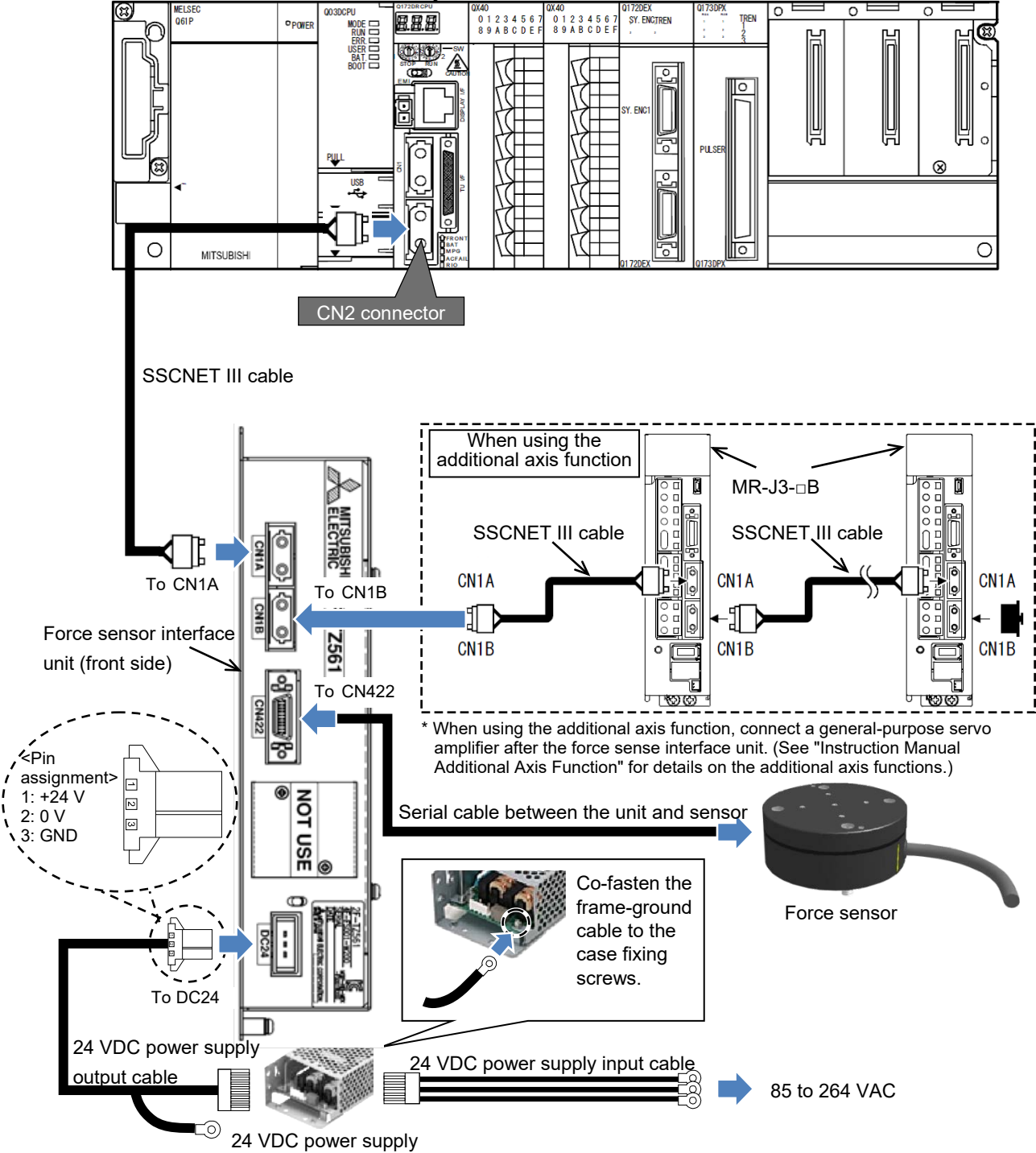

## 6.2 Force Sense Interface Unit ↔ Force Sensor

Connect the force sense interface unit and force sensor as shown below.

<Robot with internal wiring> \* RV-2/35/50/70F is excepted.

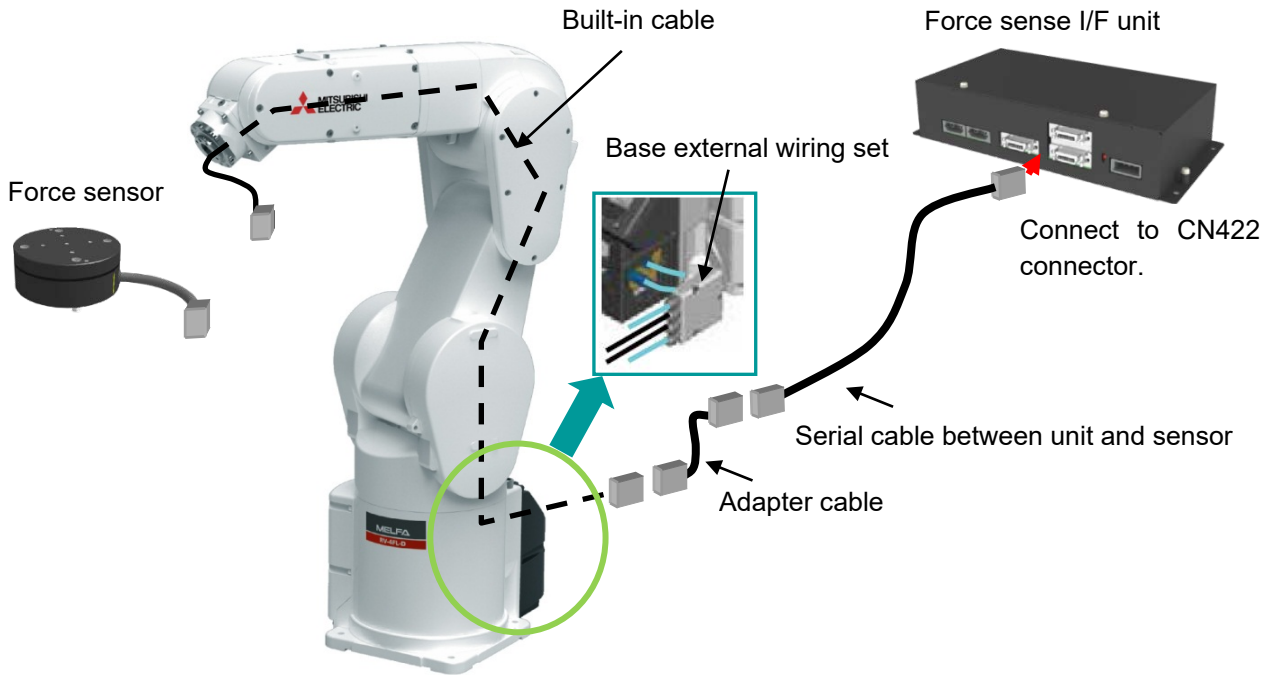

<Robot with the forearm external wiring set option> \* RV-2/35/50/70F is excepted.

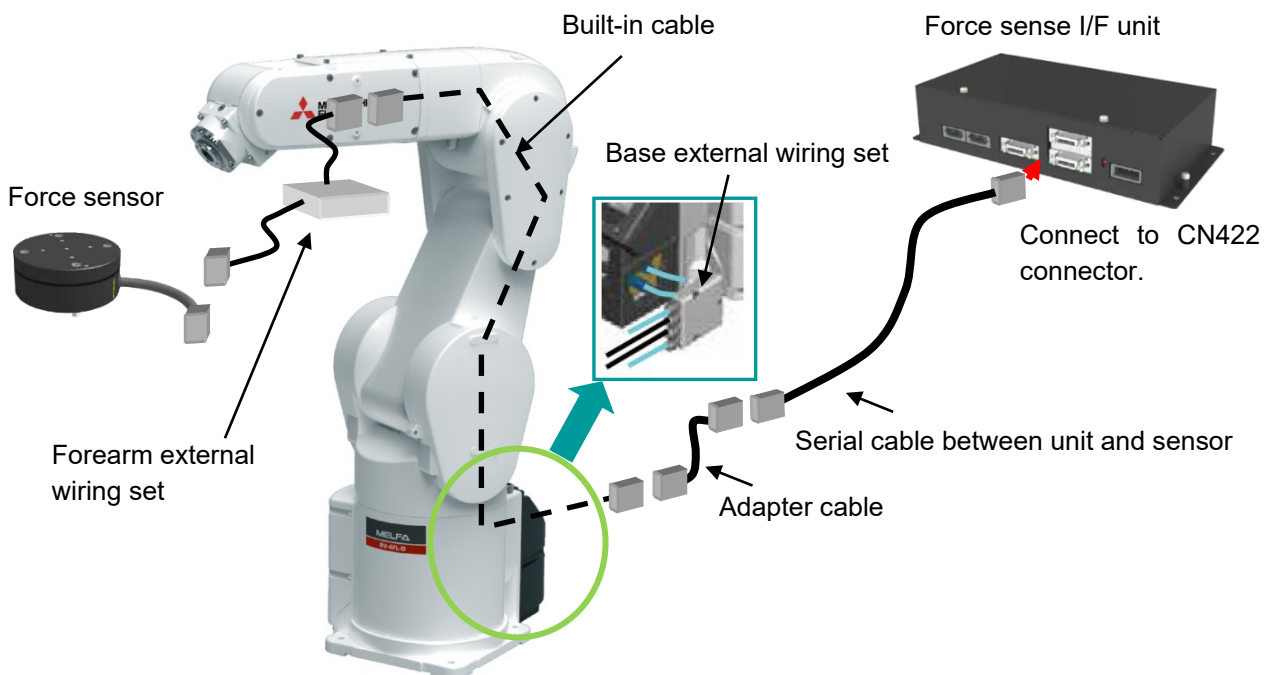

Refer to "Wiring and piping for hand" in the separate manual "Standard specifications" and "Installing the option devices" in separate manual "Robot arm setup and maintenance" for details on the cable connection.

<Standard robot>

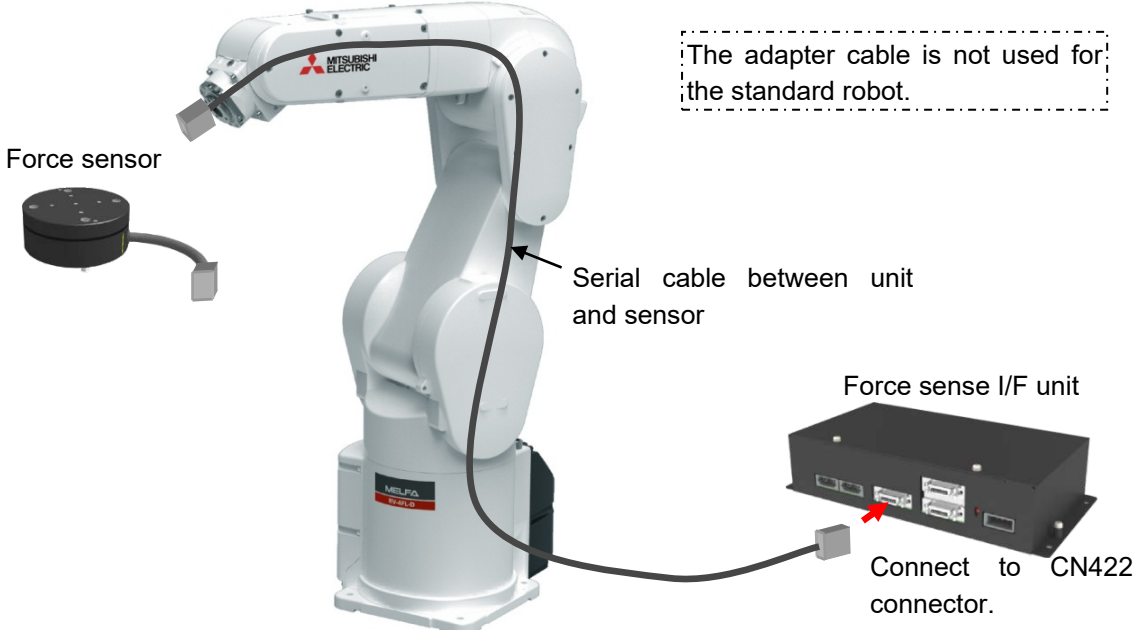

## 6.3 Turning ON the Power

Turn ON the power only after checking that the force sense interface unit, robot controller, and force sensor have been properly connected. Turn the power ON and OFF in the following order.

<When turning the power ON>

Turn ON the power to the force sense interface unit followed by the robot controller (or simultaneously).

<When turning the power OFF>

Turn OFF the power to the robot controller followed by the force sense interface unit (or simultaneously).

(There is no need to turn OFF the force sense interface unit power if only the controller is ON.)



### Caution

Do not disconnect the SSCNET III cable after turning ON the power. Furthermore, do not look directly at the light from the end of the SSCNET III connector or SSCNET III cable. Some discomfort may be experienced with direct exposure. (The SSCNET III light source is equivalent to the Class 1 source specified in JISC6802, IEC60825-1.)

## 6.4 Warm Up Operation

After the force sensor is started, the sensor output value may fluctuate due to heat generation of the internal circuit. Perform warm up operation for 10 to 30 minutes before use. The warm up operation means keeping a powered-on state.

### ■□■Precautions for use during warm up operation ■□■

For use during the warm up operation, while assuming the fluctuation of the sensor output value, perform an offset cancel frequently.

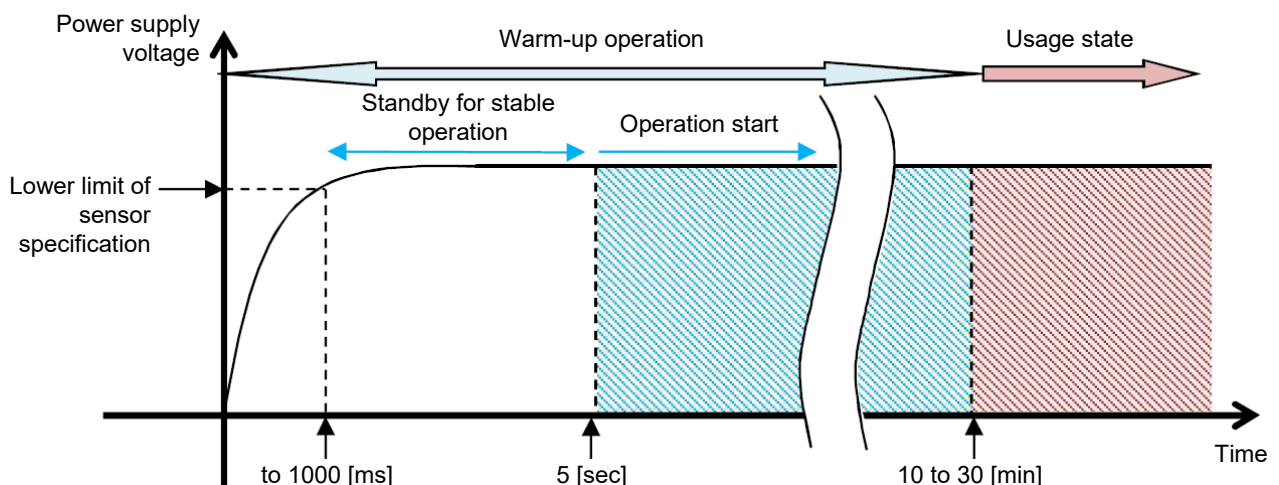

## 6.5 Default Parameter Settings

Set the following parameters after turning ON the power. (Settings can be specified efficiently using the RT ToolBox2 / R56TB / R57TB parameter setting screen. → See section [12.2](#) or [12.3](#).)

After setting all parameters, reboot the controller. Settings are updated by rebooting.

**Table 6-1: Default parameters**

Parameter	Parameter Name	No. of Elements	Description	Factory Default Setting
Force sense interface unit recognition	AXJNO	16 integers	Assigns the force sense interface unit connection. See section <a href="#">6.5.1</a> for details on the setting method.	0, 0, 0, 0, 0, 0, 0, 0, 0, 0, 0, 0, 0, 0, 0, 0
	AXMENO	16 integers		0, 0, 0, 0, 0, 0, 0, 0, 0, 0, 0, 0, 0, 0, 0, 0
Calibration	FSXTL	6 real numbers	Performs force sensor attachment calibration. See section <a href="#">6.5.2</a> for details on the setting method.	0.0, 0.0, 0.0, 0.0, 180.0, 0.0 (vertical multi-joint robots)
	FSHAND	1 integer		0 (horizontal multi-joint robots)
Force sensor tolerance	FSLMTMX	6 real numbers	Sets the force sensor tolerance. See section <a href="#">6.5.3</a> for details on the setting method.	0.0, 0.0, 0.0, 0.0, 0.0, 0.0
Force sense control offset limit	FSCORMX	2 real numbers	Sets the "maximum position offset" based on force sense control. See section <a href="#">6.5.4</a> for details on the setting method.	10.0, 10.0
Force sensor data filter	FSFLCTL	1 real number	Sets the filter time constant for force sensor data control. See section <a href="#">6.5.5</a> for details on the setting method.	1.7
Force sensor minimum control force	FSMINCTL	6 real numbers	Sets the minimum control force of the force sensor. See section <a href="#">6.5.6</a> for details on the setting method. (Controller Ver. R6h/S6h or later)	0.3, 0.3, 0.3, 0.03, 0.03, 0.03

Each setting item is described below.

### 6.5.1 Force Sense Interface Unit identification

It is necessary to set parameters at the robot controller side in order for the robot controller to recognize the force sense interface unit. Set these parameters as follows. (The same parameters as that for the additional axis function are used.)

Parameter	Parameter Name	No. of Elements	Description	Factory Default Setting
Set axis No.	AXJNO	16 integers	Sets the force sense interface unit or additional axis number for the element corresponding to the servo control axis number being used. <If using force sense interface unit> Servo control axis No.: Set "9" for axis No.1.	0, 0, 0, 0, 0, 0, 0, 0, 0, 0, 0, 0, 0, 0, 0, 0
Mechanical No. designation	AXMENO	16 integers	Enter a mechanical number corresponding to the servo control axis number being used. Always set "0" for axes that are not being used.	0, 0, 0, 0, 0, 0, 0, 0, 0, 0, 0, 0, 0, 0, 0, 0

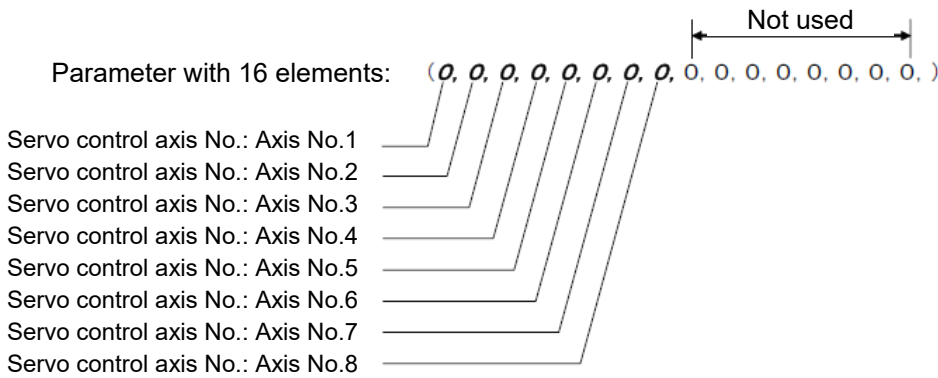

#### 6.5.1.1 If Not Using Additional Axis Functions

Set these parameters as follows if not using the additional axis functions.

AXJNO = (9, 0, 0, 0, 0, 0, 0, 0, 0, 0, 0, 0, 0, 0, 0, 0)  
 AXMENO = (1, 0, 0, 0, 0, 0, 0, 0, 0, 0, 0, 0, 0, 0, 0, 0)

#### 6.5.1.2 If Using Additional Axis Functions

AXJNO = (9, 7, 0, 0, 0, 0, 0, 0, 0, 0, 0, 0, 0, 0, 0, 0)  
 AXMENO = (1, 1, 0, 0, 0, 0, 0, 0, 0, 0, 0, 0, 0, 0, 0, 0)

<Connection example>

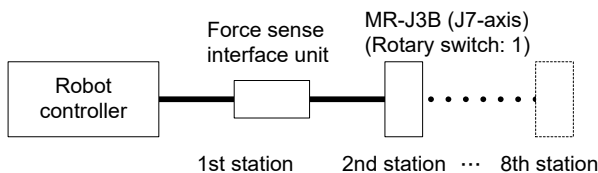

The 1st station is used by the force sense interface unit, and therefore rotary switch 0 cannot be used for the additional axis (MR-J3B). Set to 1 or onward.  
 Up to 7 additional axes (from 2nd to 8th stations) can be used.



### 6.5.2 Calibration

To use the force sense function, it is necessary to define (calibrate) the correlation between the force sensor coordinate system and force sense coordinate system (mechanical interface). Calibration is performed with the following parameter settings.

**Caution** There is a danger that the robot may move in an unintended direction if the calibration settings are incorrect. After setting the parameters, always check that they have been set correctly by following the procedure in "Chapter 7".

**Table 6-2 Details of parameters FSHAND and FSXTL**

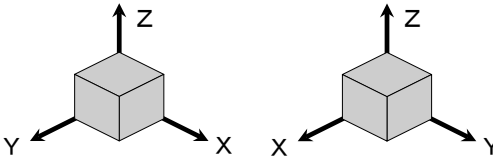
Parameter	Parameter Name	No. of Elements	Description	Factory Default Setting
Force sensor coordinate system selection	FSHAND	1 integer	<p>Selects the force sensor coordinate system hand system (left-hand system/right-hand system). The force sensor coordinate system hand system differs depending on the sensor attachment direction, and therefore it is necessary to change the setting based on the attachment direction. Set the left-hand system for recommended attachment.</p> <p>0: Force sensor coordinate system left-hand system 1: Force sensor coordinate system right-hand system</p> <p>&lt;Left-hand system&gt;    &lt;Right-hand system&gt;</p> 	0
Force sensor attachment position	FSXTL	6 real numbers	<p>Sets the positional relationship for the mechanical interface coordinate system and force sensor coordinate system.</p> <p>1st element: X-axis direction coordinate system origin offset [mm] 2nd element: Y-axis direction coordinate system origin offset [mm] 3rd element: Z-axis direction coordinate system origin offset [mm] 4th element: Coordinate axis rotation angle around X-axis [deg] 5th element: Coordinate axis rotation angle around Y-axis [deg] 6th element: Coordinate axis rotation angle around Z-axis [deg]</p>	<p>0.0, 0.0, 0.0, 0.0, 180.0, 0.0 (vertical multi-joint robots)</p> <p>0.0, 0.0, 0.0, 0.0, 0.0, 180.0 (horizontal multi-joint robots)</p>

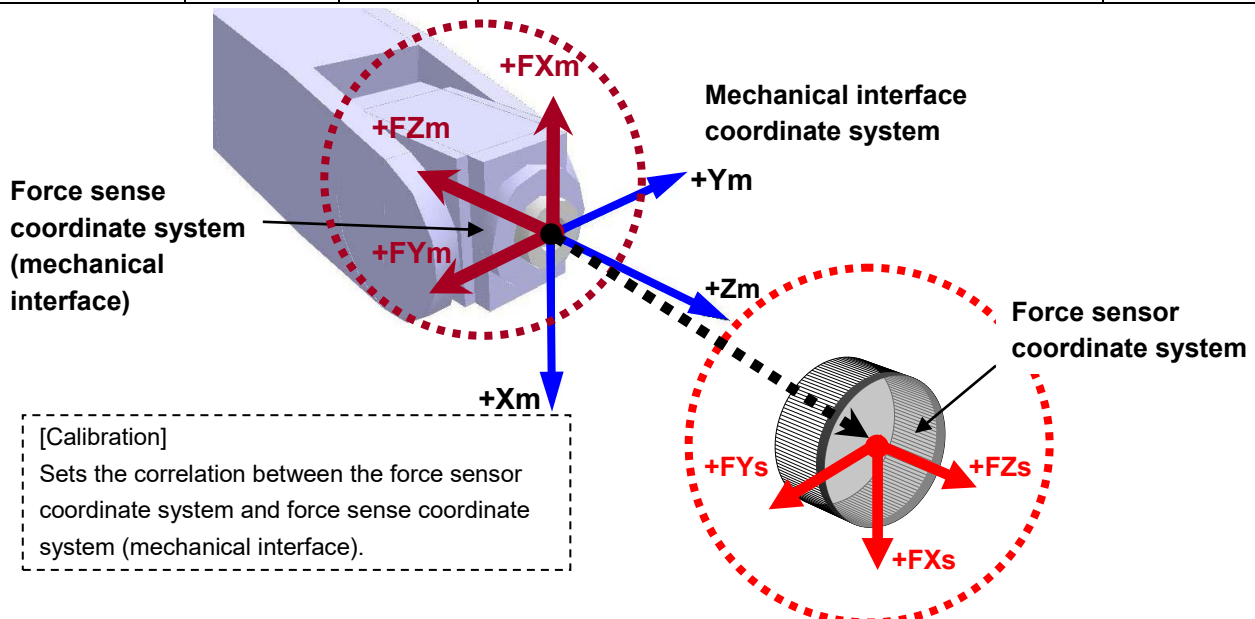

\* Refer to the next sub-section for more specific details on the setting method.

### 6.5.2.1 Parameter Setting Example 1 (for Recommended Attachment)

When the force sensor attachment is the recommended attachment (described in section [5.3](#) the parameter settings for elements 1 to 4 for FSHAND and FSXTL will be the default factory settings. Change only elements 1 to 3 for FSXTL.

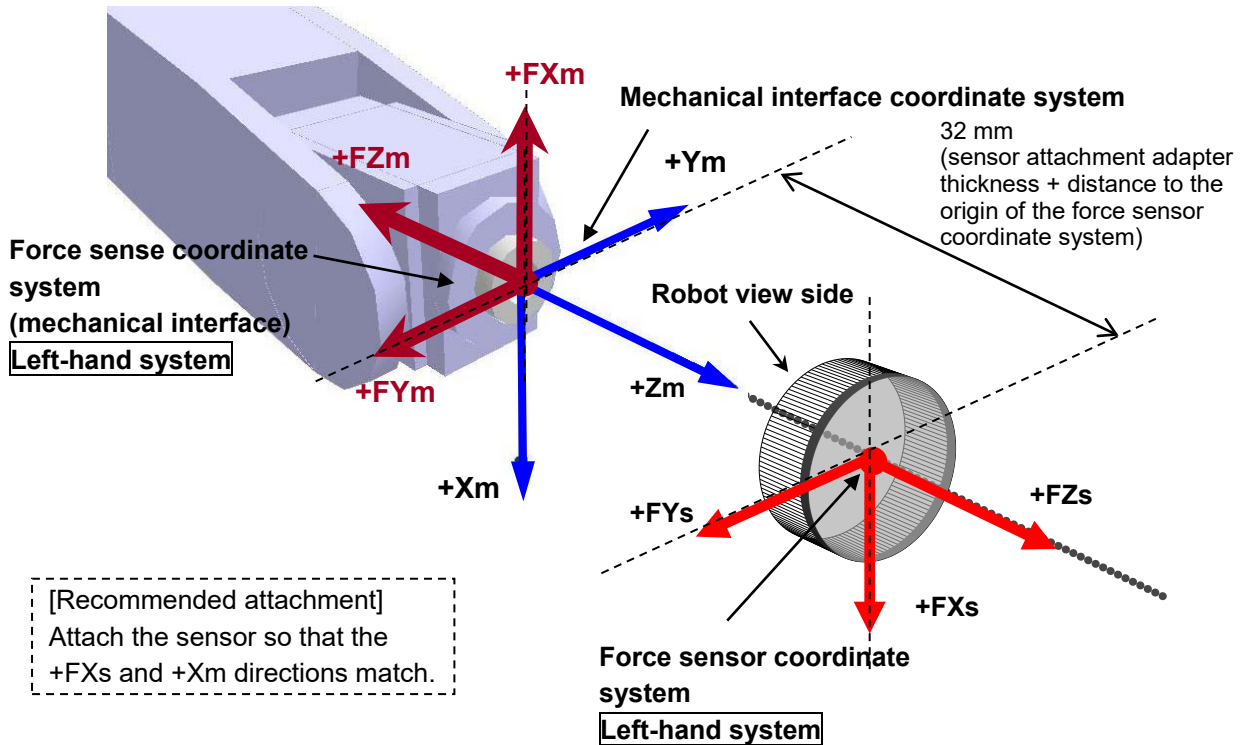

[Coordinate system hand system]

The force sensor coordinate system will be the left-hand system, and should therefore be set as follows.

FSHAND = 0 (default)

[Parallel transfer]

The force sensor coordinate system origin position as viewed from the mechanical interface coordinate system is (0, 0, 32), and therefore the FSXTL settings are as follows.

FSXTL 1st element = 0  
 FSXTL 2nd element = 0  
 FSXTL 3rd element = +32

[Rotational transfer]

To align the posture of the force sense coordinate system (mechanical interface) and force sensor coordinate system, it is sufficient to rotate +180 degrees around the Ym-axis, and therefore the FSXTL settings are as follows.

FSXTL 4th element = 0 (default)  
 FSXTL 5th element = +180 (default)  
 FSXTL 6th element = 0 (default)

### 6.5.2.2 Parameter Setting Example 2

If, as shown below, the force sensor coordinate system origin is offset 50 mm in the +Zm direction and rotated 30 degrees around the Zm-axis as viewed from the mechanical interface coordinate system, set the parameters as follows.

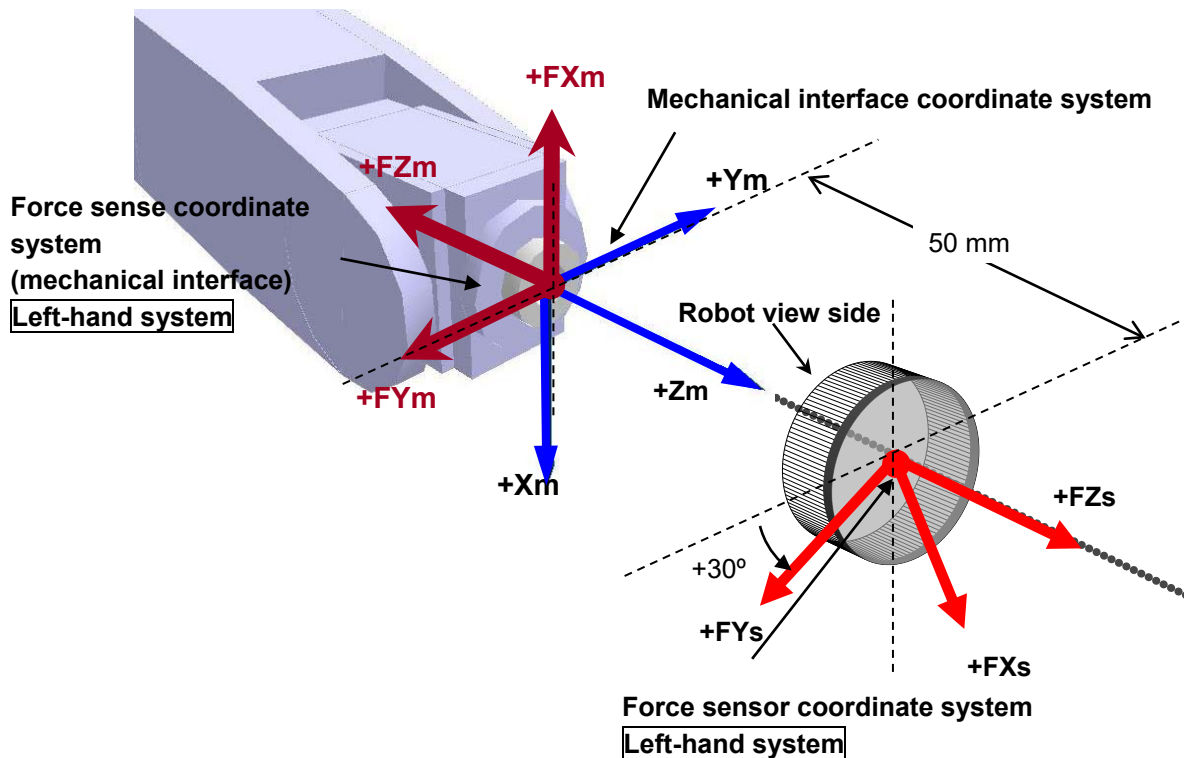

[Coordinate system hand system]

The force sensor coordinate system will be the left-hand system, and should therefore be set as follows.

FSHAND = 0

[Parallel transfer]

The force sensor coordinate system origin position as viewed from the mechanical interface coordinate system is (0, 0, 50), and therefore the FSXTL settings are as follows.

FSXTL 1st element = 0  
 FSXTL 2nd element = 0  
 FSXTL 3rd element = +50

[Rotational transfer]

To align the posture of the force sense coordinate system (mechanical interface) and force sensor coordinate system, it is sufficient to rotate +180 degrees around the Ym-axis after rotating +30 degrees around the Zm-axis, and therefore the FSXTL settings are as follows.

FSXTL 4th element = 0  
 FSXTL 5th element = +180  
 FSXTL 6th element = +30

### 6.5.3 Force Sensor Tolerance

The system is equipped with a function to stop robot operation in order to protect the force sensor if a value greater than that set for force and moment in parameter FSLMTMX is detected. Always set parameter FSLMTMX before use.

(\* The default factory setting is 0, and therefore an "H7660" error will occur if this parameter is not set.)

**Table 6-3: Sensor tolerance setting parameter**

Parameter	Parameter Name	No. of Elements	Description	Factory Default Setting
Force sensor tolerance	FSLMTMX	6 real numbers	<p>Sets the force sensor tolerance. If sensor data exceeding the force and moment set at this parameter is detected, an error (H7660) occurs and the robot is stopped. (Force sense control will be disabled.)</p> <p>1st element: Force sensor data Fx tolerance [N] 2nd element: Force sensor data Fy tolerance [N] 3rd element: Force sensor data Fz tolerance [N] 4th element: Force sensor data Mx tolerance [N·m] 5th element: Force sensor data My tolerance [N·m] 6th element: Force sensor data Mz tolerance [N·m]</p>	0.0, 0.0, 0.0, 0.0, 0.0, 0.0

- \* Set the minimum required tolerance for the work being performed, within the force sensor rated value. (Refer to section [3.6](#) for details on the force sensor rated value.)
- \* The force sensor tolerance judgment is based not on the coordinate data converted with parameter FSXTL, but with raw data (with no offset cancel) sent from the force sensor.

<If force sensor tolerance exceeded>

If error H7660 occurs when the force sensor tolerance setting is exceeded, it will no longer be possible to turn the servo ON. In such a case, remedy the situation with either of the following methods.

- (1) Temporarily clear the error from the T/B, and then retract the robot by JOG operation.  
By turning the servo ON and performing JOG operation while holding down the T/B [RESET] key, the error is temporarily cleared, allowing the robot to be moved. Move the robot to a position at which the error does not occur. (Refer to "Temporarily Resetting Errors that Cannot be Resolved" in instruction manual "Detailed Explanations of Functions and Operations" for more details.)



#### Caution

If a value larger than the force sensor rated value is applied, it may cause damage to the sensor.

## 6.5.4 Force Sensor Control Offset Limit

This parameter sets the position command offset upper limit for force sense control. If the offset exceeds this upper limit, an error (H2760) occurs. This acts as a protection function for inadequate operation or setting, and therefore the required minimum value should be set.

**Table 6-4: Force sense control offset limit setting parameter**

Parameter	Parameter Name	No. of Elements	Description	Factory Default Setting
Force sense control offset limit	FSCORMX	2 real numbers	Sets the maximum position offset for force sense control. 1st element: Position maximum offset [mm] 2nd element: Posture maximum offset [deg.] [Setting range] 1st element: 0 to +200.0 2nd element: 0 to +150.0	10.0, 10.0

## 6.5.5 Force Sensor Data Filter Setting

The force sensor data filter time constant can be changed. Sensor data that does not stabilize can be improved by increasing the time constant, however, as this affects force sense control characteristics, the default value should generally be used.

**Table 6-5: Force sensor data filter setting parameter**

Parameter	Parameter Name	No. of Elements	Description	Factory Default Setting
Force sensor data filter	FSFLCTL	1 real number	Sets the force sensor data filter time constant. [Unit]: ms [Setting range]: 0 to +1000.0	1.7

## 6.5.6 Force Sensor Minimum Control Force (Controller Ver. R6h/S6h or later)

The minimum control force of force sensor can be changed.

Even if the force sensor does not touch the workpiece, etc. during force sense control, the robot may oscillate due to stationary noise of sensor data. In this case, increasing the minimum control force improves the problem. However, increasing the minimum control force widens the dead zone width. Therefore, the sensitivity of the force sense detection/force sense control will be deteriorated.

**Table 6-6: Force sensor minimum control force parameter**

Parameter	Parameter Name	No. of Elements	Description	Factory Default Setting
Force sensor minimum force control	FSMINCTL	6 real number	Sets the minimum control force of the force sensor. 1st element: Minimum control force of force sensor Fx [N] 2nd element: Minimum control force of force sensor Fy [N] 3rd element: Minimum control force of force sensor Fz [N] 4th element: Minimum control force of force sensor Mx [Nm] 5th element: Minimum control force of force sensor My [Nm] 6th element: Minimum control force of force sensor Mz [Nm]	0.3, 0.3, 0.3, 0.03, 0.03, 0.03

# 7 Checking the Connection and Settings

Before using the force sense function, ensure that force sensor data is being sent to the robot controller in the correct coordinate system.

## 7.1 Checking Force Sensor Data Communication

Display the teaching pendant force sense control screen with the following operation, and ensure that the force sensor data is displayed correctly. If data does not show any change even when force is applied to the force sensor, there is a possibility that there is a problem with the device connection or parameter settings. If so, refer to "Chapter 6".

### 7.1.1 If Using R56TB/R57TB

If using the force sensor, an [F] button appears at the bottom of the JOG screen. By pressing this button, a force sense control screen appears on the left of the JOG screen. (If the [F] button does not appear, check the parameter settings in "section 6.5.1".)

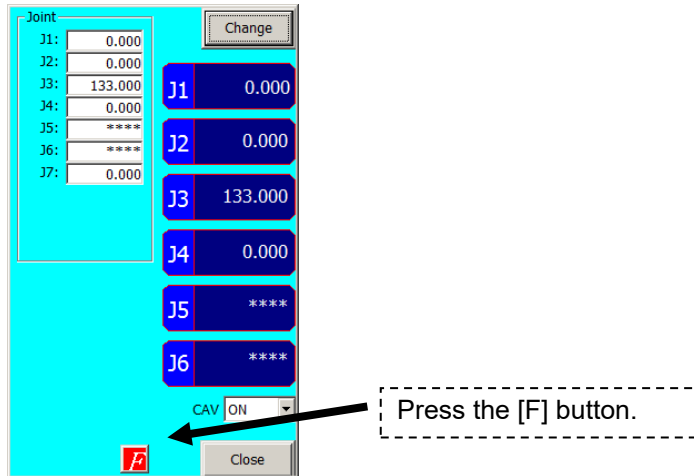

Fig. 7-1: F button display

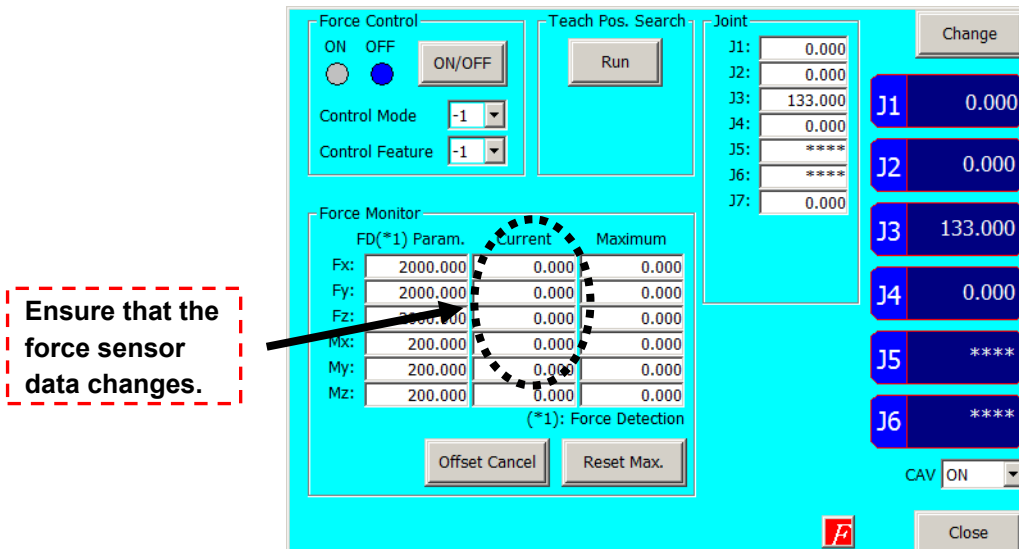
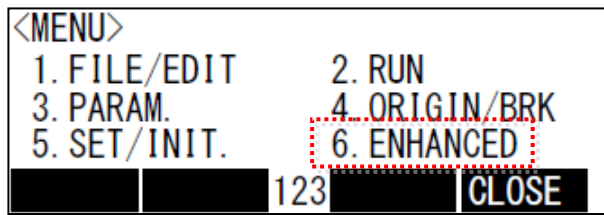
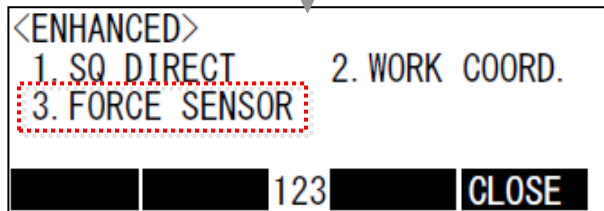

Fig. 7-2: Force sense control extension screen

## 7.1.2 If Using R32TB/R33TB



Menu screen



Extension function menu screen

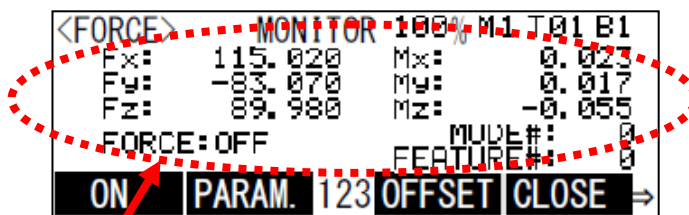

Monitor mode

Ensure that the force sensor data changes.

## 7.2 Checking the Force Sensor Attachment Coordinate System

Check force data when external force is applied by hand to the force sensor tool side. If set correctly, the correlation between the direction in which force is applied and the changed direction in the force data will be as shown in "Table 7-1". If the force data direction is different, check the calibration parameter settings in " section\_6.5.2".

**Caution** In the interest of safety, always perform this check with the servo power OFF.

**Caution** If tool coordinates are set, perform this check after disabling the tool designation. (Check after setting all parameter MEXTL setting values to 0.)

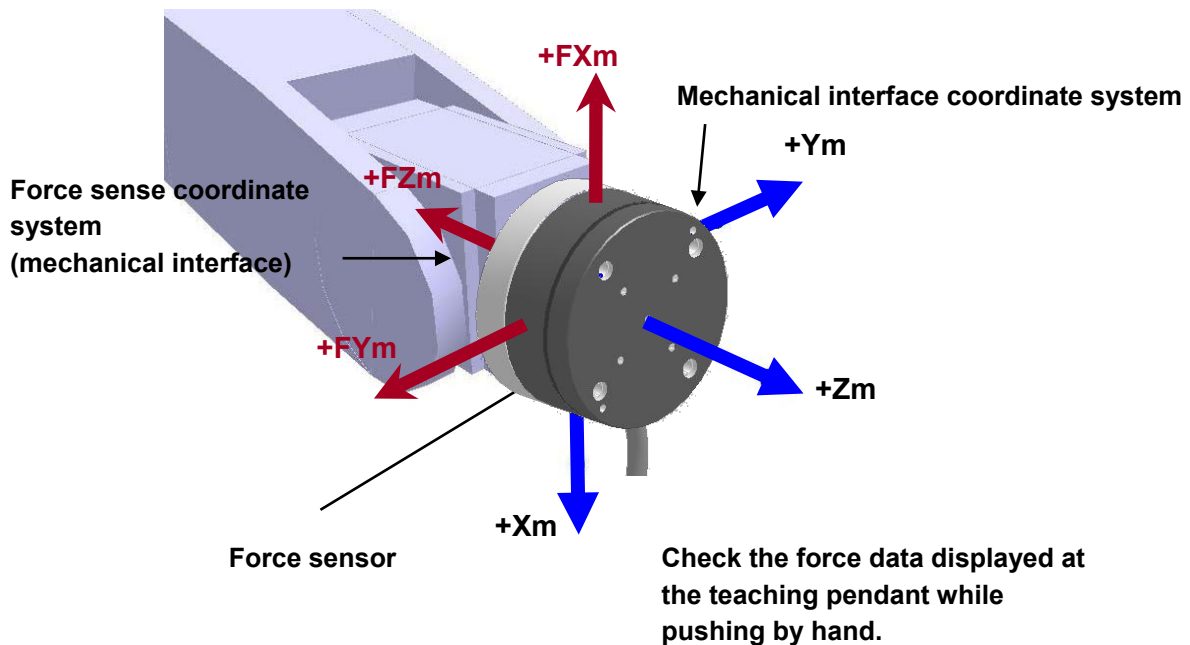

**Table 7-1: Force direction check**

	Direction in which Force Applied	Force Data Change
(1)	- $Xm$ direction	$Fx$ value changes to + direction.
(2)	- $Ym$ direction	$Fy$ value changes to + direction.
(3)	- $Zm$ direction	$Fz$ value changes to + direction.



## 8 Using the Force Sense Function (Programming)

This Chapter describes robot programming using the force sense function.

The force sense function consists of "force sense control", "force sense detection", and "force sense log" functions. Refer to the section numbers and pages under "Reference" in the following table for a "description" and "sample program" for each function.

**Table 8-1: Force sense function usage method reference list (programming)**

Function Class		Function Overview	Reference	
			Description	Sample
Force sense control	Force control	Controls push force.	<a href="#">Section 8.1</a>	<a href="#">Page 8-63</a>
		Controls force and speed.		<a href="#">Page 8-64</a>
	Stiffness control	Controls softness.		<a href="#">Page 8-66</a>
	Limited stiffness control	Controls softness. Restricts the robot's force.		<a href="#">Page 8-67</a>
	Control characteristics change	Changes control characteristics during robot movement.		<a href="#">Page 8-69</a>
Changes control characteristics in the trigger conditions.				
Force sense detection	Interrupt execution	Detects contact status and performs interrupt processing.	<a href="#">Section 8.2</a>	<a href="#">Page 8-76</a>
		Defines interrupt conditions and uses the conditions in the program.		<a href="#">Page 8-77</a>
	Data latch / referencing	Latches force sense data and uses the data in the program.		<a href="#">Page 8-79</a>
Force sense log	Log data acquisition	Acquires time series data during work.	<a href="#">Section 8.3</a>	<a href="#">Page 8-91</a>
	Log data display	Displays log data in a graph.		<a href="#">Page 8-93</a>
	Log data transfer	Transfers log data to the FTP server.		
Gravity offset cancel		This function is the offset cancel in response to a change in the direction of gravity applied to the force sensor by hand load at the time of posture change.	<a href="#">Section 8.4</a>	<a href="#">Page 8-94</a>

## 8.1 Force Sense Control

The force sense control function is used to control robot softness and push force. Depending on the application, this function switches between "force control" and "stiffness control". The characteristics of each type of control are described below.

### (1) Force control

This control mode controls the robot while pushing with a specified force. The robot moves automatically to the position at which the specified reaction force can be obtained.

The robot can be moved while pushing the workpiece with constant force and maintaining the contact status.

Force control has the following 2 modes.

#### <Speed priority mode>

If no contact has been made with the target object, the robot switches to speed control mode and moves at the specified speed toward the object.

#### <Force priority mode>

If contact has been made with the target object, the robot switches to force control mode and the robot is controlled in order that the specified reaction force can be obtained.

### (2) Stiffness control/limited stiffness control

This control mode is used to control the robot softly like a spring. By applying external force, the robot moves automatically in the direction that allows it to escape the external force.

This type of control can be used to suppress the force acting on the workpiece when performing insertion work. Furthermore, the robot position is offset while following the assembly part shape, allowing teaching position displacements to be absorbed.

In the stiffness control, the reaction force will increase in proportion to displacement. If the reaction force is too large, please set the limit value for the reaction force using the stiffness control with limit.

### (3) Position control

This control mode is used to control the robot position. Position control is applied to axes for which neither force control nor stiffness control are specified.

#### ■□■ Offset and offset speed restrictions ■□■

The restrictions shown in "Table 8-2" are applied to positional offset and offset speed for force sense control. The positional offset restriction can be changed in parameter FSCORMX.

Table 8-2: Offset restrictions

	X,Y,Z	A,B,C	Remarks
Positional offset restriction	10 [mm]	10 [deg]	Can be changed in FSCORMX.
Speed offset restriction (Automatic)	80 [mm/s]	80 [deg/s]	
Speed offset restriction (Manual)	Approx.8 [mm/s]	Approx 8 [deg/s]	

**■□■ Singular point adjacent operation restrictions ■□■**

Singular point adjacent operation cannot be performed while force sense control is enabled, regardless of interpolation or JOG operation. If the robot approaches a point adjacent to a singular point during operation, an error (L3986) occurs. Use force sense control at a position that will avoid a singular point adjacent condition.

If necessary to move the robot adjacent to a singular point, or if wishing to pass through the singular point using the singular point pass function, disable the force sense function.

**Caution**

By enabling force sense control, the robot moves automatically based on the external force acting on the sensor. Even if it seems that the robot has stopped at first glance, it may be moving at a very slow speed, and therefore attention should be paid to robot behavior while this function is enabled.

**Caution**

Even if program operation is interrupted with an HLT command while force sense control is enabled, the force sense control enabled status is maintained, and therefore the robot may move. To stop the robot, it is necessary to perform the stop entry operation or disable force sense control.

**Caution**

Always check "Chapter 5 before enabling force sense control. If there is a mistake with the connection or settings, the robot may move in an unintended direction.

**Caution**

If resuming operation after an emergency stop condition or after interrupting program operation, a command to return the robot from its stationary position to the position when the program was interrupted is generated automatically. When force sense control is enabled, the difference between the position at which the program was interrupted and the actual stoppage position will be greater than that when force sense control is disabled, and therefore the robot may move significantly when operation is resumed.

\* It is also possible to stop generation of the command to return the robot from to the position when the program was interrupted by changing the parameter RETPATH (setting for auto recovery after JOG feed when program interrupted), setting to "0". Refer to "Setting for Auto Recovery After JOG Feed when Program Interrupted" in instruction manual "Detailed Explanations of Functions and Operations" for details on the parameter RETPATH.

## 8.1.1 Force Sense Enable/Disable Commands

Force sense control is started with the MELFA-BASIC V language Fsc On command based on conditions specified for arguments "Control mode", "Control characteristics ", and "Offset cancel command". (Refer to "Chapter 9 for details on operation from the teaching pendant.) Force sense control is disabled with the Fsc Off command. (Refer to "Chapter 11 for language details.)

### Fsc On

[Function]

Enables the force sense control function using the force sensor.

[Syntax]

```
Fsc □ On, <Control mode>, <Control characteristics>, <Offset cancel designation>
```

[Terminology]

<Control mode>

Specify the control mode number for force sense control. (See section [8.1.2.](#))

Setting range: -1 to 9

<Control characteristics >

Specify the control characteristics number for force sense control. (See section [8.1.2.](#))

Setting range: -1 to 9

<Offset cancel command>

Specifies whether to cancel the force sensor data offset component.

(See section [8.1.3.](#))

Setting value: 0 (Do not cancel) / 1 (Cancel)

### Fsc Off

[Function]

Disables the force sense control function using the force sensor.

[Syntax]

```
Fsc □ Off
```

[Terminology]

None

## 8.1.2 Control Mode / Control characteristics

When enabling force sense control, it is necessary to specify conditions for starting force sense control. Table Table 8-3 shows a list of setting items relating to force sense control conditions.

**Table 8-3: Force sense control conditions**

Setting Item	Description	Remarks
Force sense control coordinate system	Defines the coordinate system for force sense control. Select from Tool coordinate system/XYZ coordinate system.	
Force sense control mode	Selects the force sense control method for each force sense control coordinate system axis. Select from Positional control/Force control/Stiffness control/limited stiffness control.	
Stiffness coefficient	Sets the softness for axes for which stiffness control/limited stiffness control is selected. The greater the value, the stiffer the movement.	
Damping coefficient	Sets the responsiveness for axes for which force control or stiffness control/limited stiffness control is selected. Adjust if vibrations are experienced on contact.	
Force sensor bias value	Bias value of the force sensor is set. The bias value of the force sensor will be a constant offset occurring in the sensor in a no load. (by tightening at the time of installation a force sensor)	These values must be set only at the time of gravity offset cancel use. These values because these are set automatically by the force calibration function, so you do not need to be set again. (See section <a href="#">8.4</a> )
Load center of gravity position	Sets the center of gravity position of the load that attached to the force sensor.	
Load mass	Sets the mass of the load that attached to the force sensor.	
Force command value	Sets the force command for force control (force priority mode). The robot pushes with the specified force.	
Limit value	Sets the limit value for the limited stiffness control. Controls the robot's force within the setting value.	
Speed command value	Sets the speed command for force control (speed priority mode). Used at such times as wishing to specify the movement speed at times of no contact.	
Mode switching judgment value	Sets the speed/force control mode switching judgment value. This is valid only when a speed command value has been set.	
Force sense control gain	Sets the response sensitivity for axes for which force control/limited stiffness control or stiffness control is selected. Adjustment is required based on the stiffness of the target object.	
Force detection setting value	Sets the force detection setting value. This is used for the force sense detection and contact detection functions.	

As shown in "Table 8-4", these conditions are registered with parameters and status variables. Up to 11 types of settings can be registered for each setting item. (9 types of parameter, 2 types of status variable)

**Table 8-4: Setting parameters and status variables for force sense control conditions**

Setting Item	Description	Parameter	Status Variable	
Control mode	<u>Force sense control coordinate system</u>	Specifies the coordinate system for force sense control. (See section 8.1.2.1.) 0: Tool coordinate system 1: XYZ coordinate system [Setting range]: 0, 1	FSCOD0#	M_FsCod0 M_FsCod1
	<u>Force sense control mode</u>	Selects the control mode for force sense control. (See section 8.1.2.2.) 0: Position control 1: Force control 2: Stiffness control 3: Limited stiffness control [Setting range]: 0, 1, 2, 3	FSFMD0#	P_FsMod0 P_FsMod1
	<u>Stiffness coefficient</u>	Specifies the stiffness coefficient for force sense control (stiffness control). (See section 8.1.2.3.) [Setting range]: 0.0 - 1000.0 [Setting unit]: X, Y, Z axes = N/mm A, B, C axes = N·m/deg (This setting is not required for axes for which stiffness control is not selected.)	FSSTF0#	P_FsStf0 P_FsStf1
	<u>Damping coefficient</u>	Sets the responsiveness for force sense control. (See section 8.1.2.4.) [Setting range]: 0.0 - 1.0 [Setting unit]: X, Y, Z axes = N/(mm/s), A, B, C axes = N·m/(deg/s)	FSDMP0#	P_FsDmp0 P_FsDmp1
	Force sensor bias value	Sets the force sensor bias value used for the gravity offset cancel.  1st element: Force sensor data Fx bias value [N] 2nd element: Force sensor data Fy bias value [N] 3rd element: Force sensor data Fz bias value [N] 4th element: Force sensor data Mx bias value [N·m] 5th element: Force sensor data My bias value [N·m] 6th element: Force sensor data Mz bias value [N·m]  (These values because these are set automatically by the force calibration function, so you do not need to be set again.)	FSBIAS0#	P_FsBias0 P_FsBias1
	Load center of gravity position	Sets the load center of gravity position used for the gravity offset cancel.  1st element: Load center of gravity position X [mm] 2nd element: Load center of gravity position Y [mm] 3rd element: Load center of gravity position Z [mm] 4th element: Rotation angle of load center of gravity A [deg] 5th element: Rotation angle of load center of gravity B [deg] 6th element: Rotation angle of load center of gravity C [deg]  (These values because these are set automatically by the force calibration function, so you do not need to be set again.)	FSGRP0#	P_FsGrPos0 P_FsGrPos1
	Load mass	Sets the load mass used for the gravity offset cancel.  [Setting unit]: kg (These values because these are set automatically by the force calibration function, so you do not need to be set again.)	FSMASS0#	M_FsMass0 M_FsMass1

Control characteristics	<u>Force command value/limit value</u>	<p>The value has different roles in the force control and the limited stiffness control.</p> <p>[In the case of force control] Sets the force command for force sense control. (See section <a href="#">8.1.2.5.</a>) [Setting range]: - force sensor tolerance value to + force sensor tolerance value [Setting unit]: X, Y, Z component = N A, B, C component = N·m (This setting is not required for axes for which force control is not selected.)</p> <p>[In the case of the stiffness control with limit] Sets the limit value for the limited stiffness control. (See section <a href="#">8.1.2.6.</a>) [Setting range]: 0 to + force sensor tolerance value [Setting unit]: X, Y, Z, L1 component = N (L1 component sets the limit value for the resultant force.) A, B, C, L2 component = N·m (L2 component sets the limit value for the resultant moment.) (The value is not required in the axis that is not applying the limited stiffness control.)</p>	FSFCMD0#	P_FsFCd0 P_FsFCd1
	<u>Speed command value</u>	<p>Sets the offset speed used in force sense control (force control) speed priority mode. (See section <a href="#">8.1.2.7.</a>) [Setting range]: 0.0 - 50.0 (0.0 only for 7th and 8th elements) [Setting unit]: X, Y, Z component = mm/s A, B, C component = deg/s</p> <p>If set to 0.0, force control for that axis will always be in force priority mode. (This setting is not required for axes for which force control is not selected.)</p>	FSSPD0#	P_FsSpd0 P_FsSpd1
	<u>Mode switching judgment value</u>	<p>Sets the judgment value for switching between the force sense control (force control) speed priority and force priority modes. (See section <a href="#">8.1.2.8.</a>) [Setting range]: - force sensor tolerance value to + force sensor tolerance value [Setting unit]: X, Y, Z component = N A, B, C component = N·m</p> <p>If the setting is the same as the force command value (parameter FSFCMD0 1 – 09), the mode for force control will always be force priority for that axis. (This setting is not required for axes for which force control is not selected.)</p>	FSSWF0#	P_FsSwF0 P_FsSwF1
	<u>Force sense control gain</u>	<p>Sets the response sensitivity for force sense control. (See section <a href="#">8.1.2.9.</a>) [Setting range]: 0.0 - 300.0 [Setting unit]: X, Y, Z axis component = 10<sup>-3</sup> mm/N A, B, C axis component = 10<sup>-3</sup> deg/(N·m)</p>	FSFGN0#	P_FsGn0 P_FsGn1
	<u>Force detection setting value</u>	<p>Sets the force detection setting for interrupt signals and data retention trigger for each coordinate axis. (See section <a href="#">8.1.2.10.</a>) [Setting range]: 0.0 - force sensor tolerance value [Setting unit]: X, Y, Z axis component = N A, B, C axis component = N·m</p>	FSFLMT0#	P_FsFLm0 P_FsFLm1

(# corresponds to group Nos. 1 to 9.)

- For those settings items that are underlined, setting is required for each coordinate axis of the force sense coordinate system. This corresponds to X, Y, Z, A, B, and C in this order from the 1st element of parameters and status variables. (Coordinate system definition is based on the "force sense control coordinate system".)
- There is no need to reboot the controller after writing parameters relating to control mode/control characteristics. (Settings are immediately updated.)
- Settings can be specified efficiently using the RT ToolBox2/R56TB/R57TB force sense function parameter setting screen. (See section [12.2](#) or [12.3.](#))

All parameter settings are classified by "condition groups" consisting of the control mode and control characteristics, and "condition Nos." constituting numbers -1 to 9. When specifying conditions with the Fsc On command, they are specified with a combination of these "condition groups" and "condition Nos."

Statement structure: Fsc□On, <Control mode>, <Control characteristics >, <Offset cancel designation>

If, for example, using the condition settings highlighted by the red boxes in Table 8-5 to start force sense control, set "1" for the "Control mode" argument and "-1" for the <Control characteristics > argument. (See section [8.1.3](#) for detail on <Offset cancel designation".)

Table 8-5: Condition groups and condition Nos.

		Setting Item	Condition No.				
			-1	0	1	2 to 8	9
Condition group	Control mode	Force sense control coordinate system	M_FsCod1	M_FsCod0	FSCOD01	FSCOD0#	FSCOD09
		Force sense control mode	P_FsMod1	P_FsMod0	FSFMD01	FSFMD0#	FSFMD09
		Stiffness coefficient	P_FsStf1	P_FsStf0	FSSTF01	FSSTF0#	FSSTF09
		Damping coefficient	P_FsDmp1	P_FsDmp0	FSDMP01	FSDMP0#	FSDMP09
		Force sensor bias value	P_FsBias1	P_FsBias0	FSBIAS01	FSBIAS0#	FSBIAS09
		Load center of gravity position	P_FsGrPos1	P_FsGrPos0	FSGRP01	FSGRP0#	FSGRP09
		Load mass	M_FsMass1	M_FsMass0	FSMASS01	FSMASS0#	FSMASS09
	Control characteristics	Force command value/limit value	P_FsFCd1	P_FsFCd0	FSFCMD01	FSFCMD0#	FSFCMD09
		Speed command value	P_FsSpd1	P_FsSpd0	FSSPD01	FSSPD0#	FSSPD09
		Mode switching judgment value	P_FsSwF1	P_FsSwF0	FSSWF01	FSSWF0#	FSSWF09
		Force sense control gain	P_FsGn1	P_FsGn0	FSFGN01	FSFGN0#	FSFGN09
Force detection setting value		P_FsFLm1	P_FsFLm0	FSFLMT01	FSFLMT0#	FSFLMT09	

(# corresponds to group Nos. 2 to 8.)



### 8.1.2.1 Force Sense Control Coordinate System

The coordinate systems used with force sense control are specified from the following.

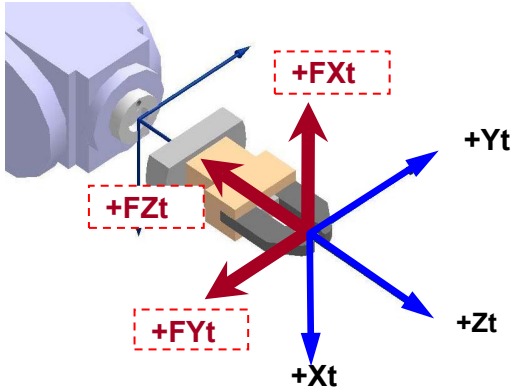
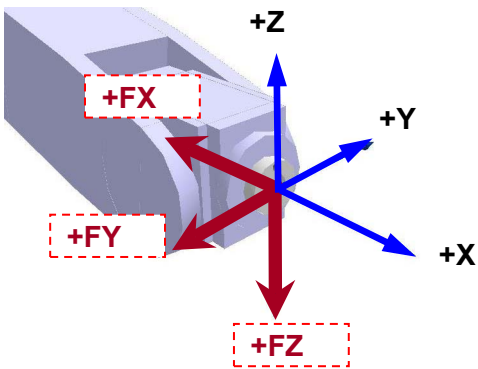
Tool coordinate system	XYZ coordinate system
<p data-bbox="150 454 593 483">Force sense coordinate system (tool)</p>  <p data-bbox="217 913 724 1025">The coordinate system direction is the direction in which the tool coordinate system symbol is reversed, and the origin is the tool coordinate system origin.</p>	<p data-bbox="836 454 1289 483">Force sense coordinate system (XYZ)</p>  <p data-bbox="896 902 1469 1037">The coordinate system direction is the direction in which the XYZ coordinate system symbol is reversed, and the origin is the mechanical interface coordinate system origin.</p>

### 8.1.2.2 Force Sense Control Mode

The force sense control mode is set for each axis. The characteristics of each mode are as follows.

**Table 8-6: Force sense control mode characteristics**

	Position Control Mode	Force Control Mode	Stiffness Control Mode/ Limited stiffness control
Control method	As with normal robot control, the robot is controlled with position commands.	The robot is controlled while pushing with a specified force. The force size and direction are set with the "Force command value".	Controls the robot softly. Softness is set with the "Stiffness coefficient". The limit value for the limited stiffness control is set with the "limit value".
Application	This is used in combination with force control and stiffness control.	Work involving pushing Grinding work	Fitting/insertion work Copying/teaching work

### 8.1.2.3 Stiffness Coefficient

Stiffness control/limited stiffness control softness is specified with the stiffness coefficient. The stiffness coefficient is the equivalent of spring constant, and the greater the value, the harder the control.

<Correlation between teaching position and reaction force>

If stiffness control mode is selected, when an external force acts on the arm tip, resulting in displacement between the teach position and actual position, the robot moves to a position at which the reaction force corresponding to the "displacement" and "stiffness coefficient" can be obtained.

In the following image, stiffness control is performed only for the tool Z-axis. By setting 0.5 [N/mm] for the Z-direction stiffness coefficient, and the teaching position at 5 mm below the contact surface, force F produced on the contact surface is calculated as follows.

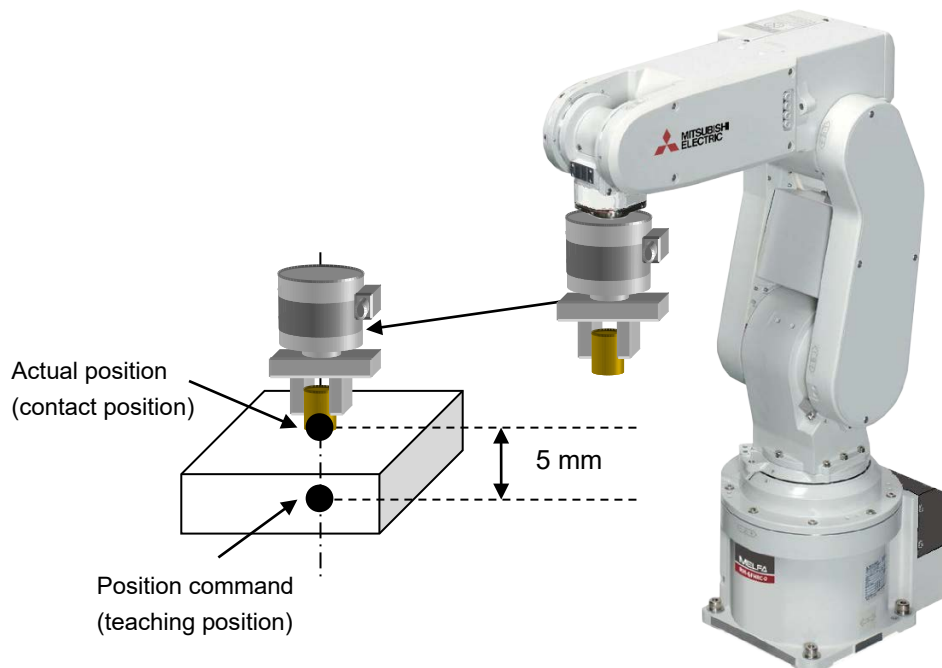

$$F = 0.5 \text{ [N/mm]} \times 5 \text{ [mm]} = 2.5 \text{ [N]}$$

The smaller the stiffness coefficient, the smaller the reaction force, helping to deal with greater displacements. When 0.0 is set with the stiffness coefficient, the reaction force is not generated in the case of the position is changed by external force.

When the limited stiffness control, the robot is controlled within the specified reaction force that is set with limit value.

### 8.1.2.4 Damping Coefficient

Vibrations that occur when applying positional offsets with force sense control (stiffness control, limited stiffness control, or force control) are adjusted with the damping coefficient. The greater the value, the greater the effect in suppressing vibrations, however, positional offsetting is delayed with sudden changes in force, resulting in a greater force applied the moment contact is made with the workpiece.

If required, damping coefficient adjustments should be made after force sense control gain adjustment is complete. (Vibrations also occur if the force sense control gain is too great.)

### 8.1.2.5 Force Command Value

Sets the force command value for force control (force priority mode). When force control is enabled, the robot moves so that the reaction force specified with the force command value can be obtained.

If no external force acts on the robot (if no contact is made), the robot moves in the force command value direction and reaction force direction (direction in which the specified force is produced when contact is made.)

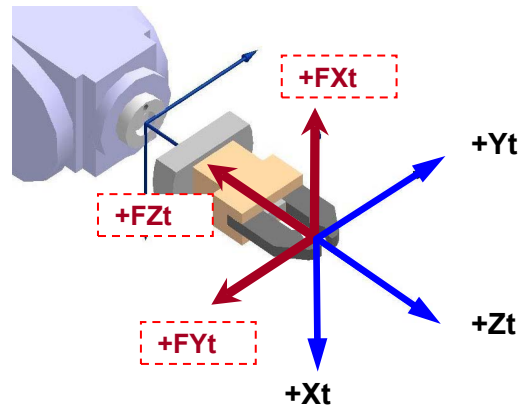

<Example> The movement when force control mode is specified only for the FZt direction and the force command value is  $FZt = +5 \text{ N}$  is as follows.

**Table 8-7: Behavior corresponding to force command**

	Robot Behavior
If contact made (if external force acting)	The robot is moved while offsetting its position until $FZt = 5 \text{ N}$ .
If no contact made (if no external force acting)	The robot moves in the +Zt direction so that external force is produced in the force command direction when contact is made. The movement speed is proportional to the force sense control gain x force command.

The movement speed when no external force is acting is dependent on the force sense control gain and force command. (The greater the force sense control gain and force command, the faster the movement.) If specifying the speed at this point, set the "Speed command value".

### 8.1.2.6 Limit value

Sets the limit value for the limited stiffness control. When an external force acts on the arm tip and the displacement occurs between the teach position and actual position while the limited stiffness control is enabled, the robot moves to a position at which the reaction force corresponding to the "displacement" and "stiffness coefficient" can be obtained. In the normal stiffness control, when the stiffness coefficient or displacement is increased, the reaction force becomes large. On the other hand, in the limited stiffness control, the force is automatically controlled so that the reaction force does not exceed the specified limit value.

Since the limit is applied to the command value, as the value of the sensor may temporarily exceed the limit value.

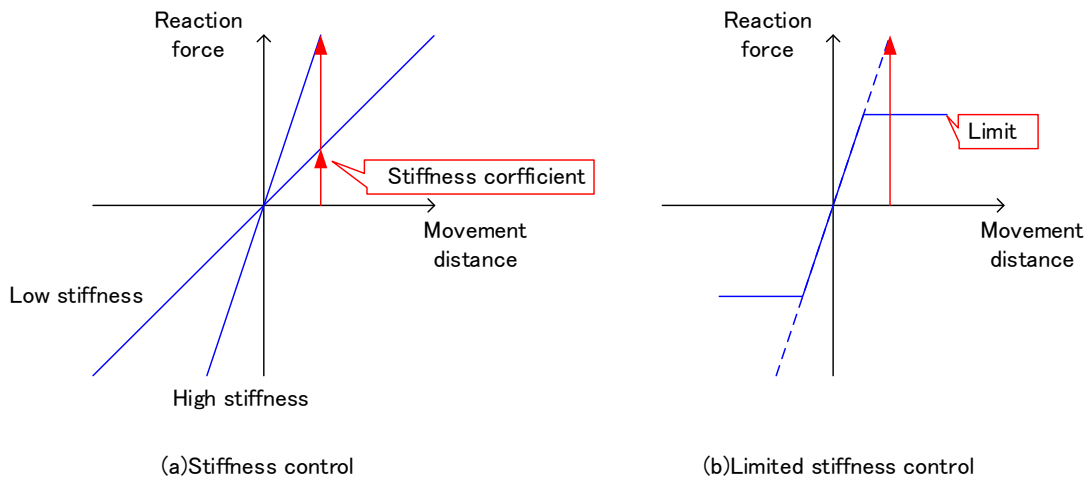

### 8.1.2.7 Speed Command Value

Specifies the movement speed for force control (speed priority mode) when no contact is made with the target object. Use if performing work while automatically switching between speed control and force control, or to minimize impact by restricting the approach speed to the target object. Set the switching condition for "speed priority mode" and "force priority mode" with the "Mode switching judgment value". If the speed command value is 0.0, priority mode switching is not performed. Force priority mode is always performed.

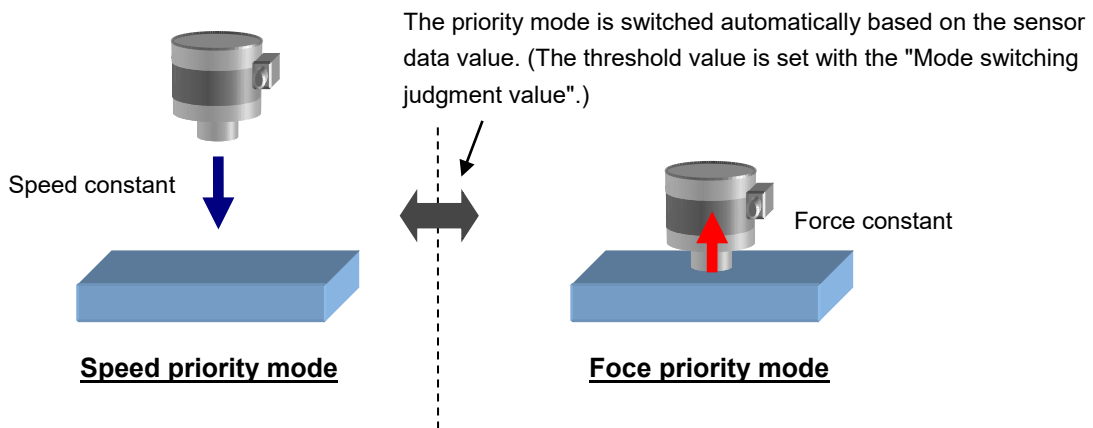

When 0.0 is set with the speed command value, the priority mode is not switched. The robot always operates in the force priority mode.

**⚠ Caution**

The speed specified with the speed command value is the force sense control offset speed, and not the actual robot movement speed. If the robot is not moving in other than in force sense control, such as when performing interpolation commands or JOG operation, but moving only in speed priority mode, the "specified offset speed = robot movement speed".  
 If interpolation commands or JOG operation are being performed in speed priority mode, the "(specified offset speed + speed specified for interpolation, JOG operation) = robot movement speed".

**8.1.2.8 Mode Switching Judgment Value**

Sets the threshold used for switching between "speed priority mode" and "force priority mode" when the speed command value is set for force sense control (force control).

The speed priority mode and force priority mode switch as follows based on the force command value and switching judgment value, and force sensor data magnitude correlation.

**Table 8-8 Priority mode switching**

Data Magnitude Correlation		Priority Mode	Applicable Area for Each Priority Mode
Force Command Value and Switching Judgment Value	Sensor Data and Switching Judgment Value		
Force command value > switching judgment value	Sensor data ≥ switching judgment value	Force priority mode	
	Sensor data < switching judgment value	Speed priority mode	
Force command value < switching judgment value	Sensor data ≤ switching judgment value	Force priority mode	
	Sensor data > switching judgment value	Speed priority mode	
Force command value = switching judgment value	-	Force priority mode	

## &lt;Force priority mode&gt;

- Data from the force sensor is used to control the robot until the force specified with the force specification value is reached.
- The robot moves in the direction which satisfies the force specification value by following the axis direction for which force control is specified.
- The offset speed for force control is restricted to the speed command value or below.

## &lt;Speed priority mode&gt;

- The robot is controlled so that the speed specified with the speed command value is reached.
- The robot moves in the direction which satisfies the force specification value by following the axis direction for which force control is specified.

Example: If the robot is moved toward the target object at 1.0 [mm/s] in the -Z direction with a force of 0.5 [N] until contact is made, and then 1.0 [N] is applied following contact:

- Force command value : (0.0, 0.0, 1.0, 0.0, 0.0, 0.0)
- Speed command value : (0.0, 0.0, 1.0, 0.0, 0.0, 0.0)

**■□■ Mode switching judgment value setting ■□■**

If the "force command value" and "mode switching judgment value" are near one another, sensor noise or vibrations may be generated while pushing with force control at a specified force, resulting in the possibility that switching between force priority mode or speed priority mode may occur unexpectedly. Adjust the judgment threshold to avoid sensor noise or vibrations while referring to the log data. Alternatively, use the FsGChg command or the FsCTrg command to change the control features.

- Switching judgment value : (0.0, 0.0, 0.5, 0.0, 0.0, 0.0)

### 8.1.2.9 Force Sense Control Gain

Force sense control gain is a parameter used to adjust the force sense control responsiveness. The higher the setting, the higher the force sense control responsiveness, however, increasing the value too much will result in an ultrasensitive response when contact is made, resulting in unstable operation.

Force sense control gain is affected by the stiffness of the target object, and therefore it is necessary to change the gain setting value based on the object. Adjust the gain setting value using the following method.

## &lt;Adjustment method&gt;

- 1) Set 1.0 as an initial value to adjust the gain setting value to the axis which executes the force sense control.
- 2) Move the robot at low speed by JOG operation in the axis direction for which force sense control (force control/stiffness control/limited stiffness control) is enabled until contact is made with the target object. (speed override: approx. 5%)
- 3) If the robot rebounds in the opposite direction from the movement direction when contact is made, it is necessary to lower the gain setting value. (The gain setting value can be increased if the robot does not rebound.)

## &lt;Setting guide&gt;

Target Object stiffness	Force Sense Control Gain
1.0 N/mm	50.0
10.0 N/mm	8.0
100.0 N/mm	1.0

If the force sense control gain setting is 0.0, offsetting with force sense control will not be performed. Control will be the same as normal position control (normal control). Control can be changed from position control to force control/stiffness control/limited stiffness control or vice versa by changing the gain setting value during robot movement. (Use the FsGChg command or the FsCTrg command.)

### 8.1.2.10 Force Detection Setting Value

The force detection setting value is used with the following functions. Refer to the respective items.

Function Class		Description	Reference
Force sense detection	Interrupt execution	Monitors the status with regard to the force detection setting value. (The start-up and shut-down status with regard to the force detection setting value can be obtained.)	See section <a href="#">8.2</a> .
	Data latch	Sensor data and position data at the moment the force detection setting value is exceeded is retained.	
Force sense control (T/B)	Contact detection	JOG operation is stopped the moment the specified force (moment) is exceeded.	See section <a href="#">9.1</a> .

### 8.1.3 Offset Cancel Designation

To operate the force sense control function properly, it is necessary to perform a force/moment offset cancel (error component elimination) for each axis with no external force (robot stopped or with no contact made) other than gravity acting on the sensor.

The following two offset cancel methods are available.

	Offset Cancel Method	Details
1	Method using Fsc On command	Set "1" for the Fsc On command argument <Offset cancel designation>.
2	Offset cancel operation from T/B	See section <a href="#">9.1.1.1</a> .

<Offset cancel conditions>

If performing offset cancel, always do so with the following conditions satisfied.

- Robot at complete stop
- No contact with hand/workpiece, etc. (no external force acting)



#### Caution

By performing an offset cancel with contact made (with external force other than gravity acting on sensor), the force balance will be upset, and force control/stiffness control will not function properly. Always perform the offset cancel with no contact made with the sensor.



#### Caution

If executing the Fsc On command when contact is made, disable the offset cancel designation. In a case such as this, it is necessary to perform the offset cancel at a position of no contact beforehand.



#### Caution

If the force sensor is used for a long time, the sensor's output value may be fluctuated by effect of the temperature drift. Create programs to execute the offset cancel periodically.

<Force sensor temperature drift>

If using the force sensor for long periods of time, sensor output values may fluctuate due the influence of temperature drift. Create a program to periodically perform offset cancel.

<Influence of gravity>

If changing the robot posture significantly, the force component applied to the sensor by gravity will change, resulting in the need to perform offset cancel again. If the posture changes significantly with each job, it is necessary to perform offset cancel again after the posture changes.

## 8.1.4 Control characteristics Change Commands

The "control characteristics " (force sense control gain, force specification value/limit value, speed command value, mode switching judgment value, force detection setting value) settings can be changed while force sense control is enabled using the MELFA-BASIC V language FsGChg and FsCTrg commands.

Changing the "control characteristics " during movement facilitates work with a great degree of freedom. (The "control mode" cannot be changed until the Fsc Off command has been executed.)

Refer to "Chapter [11](#) Language Specifications" for details on each command.

### FsGChg (Fs gain change)

#### [Function]

Changes the control features of force sense control during movement.

#### [Syntax]

```
FsGChg □ <Change start position>, <Change time>, <Control features No. after change>
```

#### [Terminology]

##### <Change start position>

Specifies the position at which the change to the control features setting is started.

Specify with a percentage for the next interpolation start point → end point.

Setting range: 0 to 100 [%]

##### <Change time>

Specifies the time taken to change the control features setting.

The mode switching judgment value and force detection setting value changes immediately, regardless of this setting.

Setting range: 1 to 1000 [ms]

##### <Control features No. after change>

Specifies the control features value for which the force control gain, force command value, and force detection setting value, speed command value and mode switching judgment value are set after the change.

Setting range: -1 to 9

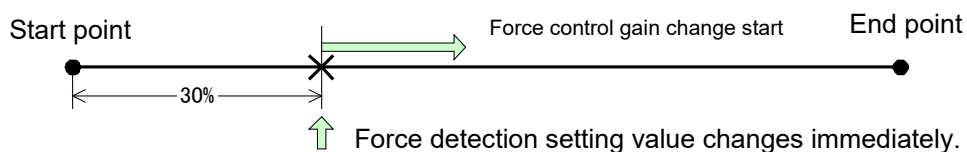

Example) in case of the change start position set at 30%



**FsCTrg (FsC trigger)****[Function]**

Sets the control feature change for force sense control with an Mo trigger.

\* If using the FsCTrg command, it is necessary to set the Mo trigger conditions beforehand.

**[Syntax]**

```
FsCTrg □ <Trigger No.>, <Change time>, <Control feature group No. after change>
          [, <Timeout>, <Execution method> [, <Error specification>]
```

**[Terminology]****<Trigger No.>**

Specifies the Mo trigger No. used to change the control feature with a constant.  
Setting range: 1 to 3

**<Change time>**

Specifies the time taken to change the control feature.  
The force detection setting value and mode switching judgment value change immediately, regardless of this setting.  
Setting range: 1 to 1000 [ms]

**<Control feature group No. after change>**

Specifies the control feature group No. applied after the change.  
Setting range: -1 to 9

**<Timeout>**

Specifies the Mo trigger timeout monitoring time with a constant.  
Setting range: 0 to 60 [s]  
If omitted, timeout processing is not performed.

**<Execution method>**

Specifies the timeout monitoring execution method for this command with a constant.  
0: Proceeds to next program without waiting for Mo trigger ON.  
1: Does not proceed to next program until Mo trigger turns ON or timeout reached.

**<Error specification>**

Specifies whether an error occurs following a timeout.  
0: An error occurs.  
1: An error does not occur.  
If omitted, an error occurs following a timeout.

By changing the control characteristics with the FsGChg command, the differences in changes to control characteristics made with the Mo trigger command are as follows.

Command	FsGChg Command	Mo Trigger Command (Def MoTrg/FsCTrg Command)
Trigger condition	Interpolation progress	Position command (orthogonal, joint) FB position (orthogonal, joint) Force sense position command Force sensor data (each axis, resultant force, resultant moment) Input signal (1-bit) Output signal (1-bit)
Change start timing	When interpolation progress for first interpolation command reaches specified value after executing FsGChg command.	When Mo trigger conditions defined with Def MoTrg command are satisfied
Restrictions	Changes are only possible while an interpolation command is being executed. To disable changes, it is necessary to disable force sense control.	If during operation, changes are possible regardless of whether an interpolation command has been executed. The change specification only can be disabled without disabling force control.

## 8.1.5 Usage Example (Force Sense Control)

This section describes the specific usage method for each function using sample programs.

<Control mode / control characteristics settings>

The sample programs described below set the "control mode" and "control characteristics" using status variables. The same settings are also possible using parameters and should be substituted as appropriate. (See following compatibility table.)

Setting Item		Status Variable (* = 0, 1)	Parameter (#=1 to 9)	Force Sense Control Mode			
				Position Control	Force Control	Stiffness Control	Limited stiffness control
Control mode	Force sense control coordinate system	M_FsCod*	FSCOD0#	○	○	○	○
	Force sense control mode	P_FsMod*	FSFMD0#	○	○	○	○
	Stiffness coefficient	P_FsStf*	FSSTF0#	×	×	○	○
	Damping coefficient	P_FsDmp*	FSDMP0#	×	△	△	△
	Force sensor bias value	P_FsBias*	FSBIAS0#	△	△	△	△
	Load center of gravity position	P_FsGrPos*	FSGRP0#	△	△	△	△
	Load mass	M_FsMass*	FSMASS0#	△	△	△	△
Control characteristics	Force command value	P_FsFCd*	FSFCMD0#	×	○	×	×
	Limit value			×	×	×	○
	Speed command value	P_FsSpd*	FSSPD0#	×	○	×	×
	Mode switching judgment value	P_FsSwF*	FSSWF0#	×	○	×	×
	Force sense control gain	P_FsGn*	FSFGN0#	×	○	○	○
	Force detection setting value	P_FsFLm*	FSFLMT0#	△	△	△	△

(○ : Setting required, △ : Set as required, × : No setting required)

### Caution

The sample programs contained in this manual have been prepared for the purpose of understanding force sense functionality, and operation stability cannot be guaranteed. If using a sample contained in this manual on an actual system, please use with a sufficient understanding of the program content. Furthermore, the appropriate values for force sense control gain and damping coefficient, etc will vary greatly depending on the working environment, and therefore adjustments should be made with care.

## Force Control 1

### ■ Operation details

The robot is pushed in the Z-direction with a force of 10 N.

- Force control is started from the PStart position.
- The robot is moved in the force sense control coordinate system (tool) +FZt direction until a reaction force of 10 N can be obtained.

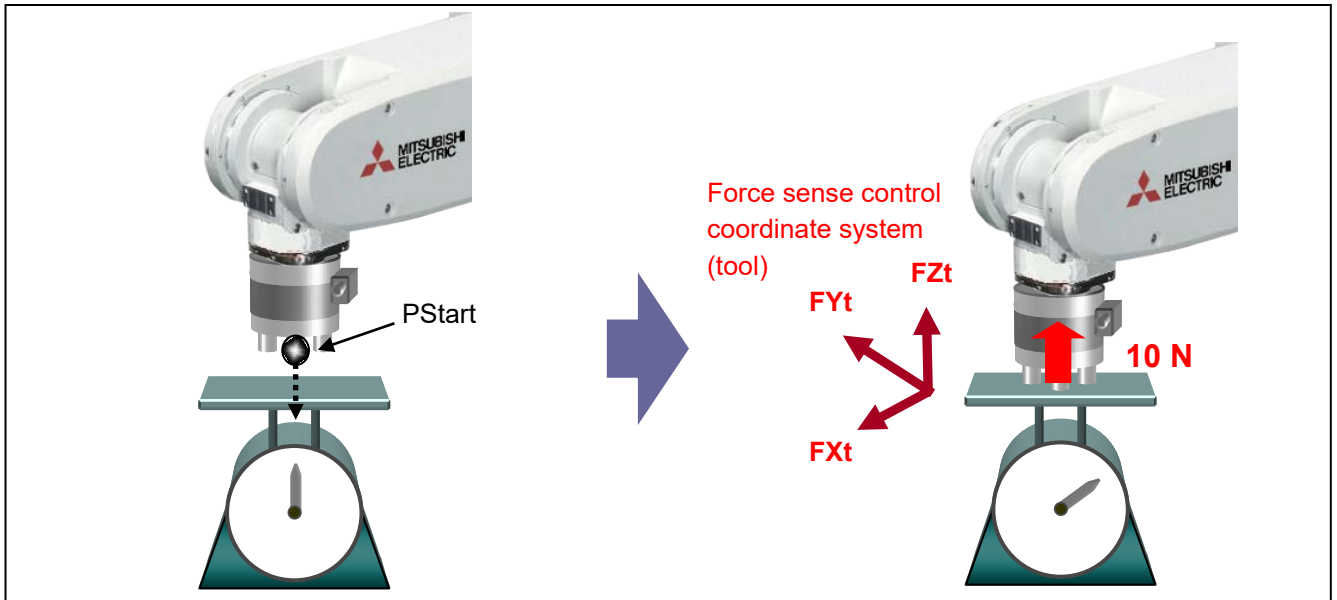

### ■ Program example <Sample program F801.prg>

'[Control mode (0)]	
P_FsStf0 = (+0.00,+0.00,+0.00,+0.00,+0.00,+0.00)(0,0)	'Stiffness coefficient [N/mm] ← No setting required
P_FsDmp0 = (+0.00,+0.00,+0.00,+0.00,+0.00,+0.00)(0,0)	'Damping coefficient
<b>P_FsMod0 = (+0.00,+0.00,+1.00,+0.00,+0.00,+0.00)(0,0)</b>	<b>'Force sense control mode (Z-axis force control)</b>
<b>M_FsCod0 = 0</b>	<b>'Force sense control coordinate system (tool)</b>
'[Control characteristics (0)]	
<b>P_FsGn0 = (+0.00,+0.00,+30.00,+0.00,+0.00,+0.00)(0,0)</b>	<b>'Force control gain [μm/N] ← Adjustment required</b>
P_FsFLm0 = (+0.00,+0.00,+0.00,+0.00,+0.00,+0.00)(0,0)	'Force detection setting value [N]
<b>P_FsFCd0 = (+0.00,+0.00,+10.00,+0.00,+0.00,+0.00)(0,0)</b>	<b>'Force command (10 N in FZt direction)</b>
P_FsSpd0 = (+0.00,+0.00,+0.00,+0.00,+0.00,+0.00)(0,0)	'Sets speed control mode speed.
P_FsSwF0 = (+0.00,+0.00,+0.00,+0.00,+0.00,+0.00)(0,0)	'Sets force/speed judgment value.
**** <Force control (Z-axis)> ***	
Servo On	
Mov PStart	'Move to start point.
Dly 1	
<b>Fsc On,0,0,1</b>	<b>'Force sense control enabled (drop start with force control)</b>
Dly 10	
<b>Fsc Off</b>	
End	

### ■ Description

- 1) The "control mode" and "control characteristics " are set at the beginning of the program. (In this example they are set with status variables, however, they can also be set with parameters.)
- 2) Force sense control is started with the Fsc On command based on the conditions set for "Control mode (0)" and "Control characteristics (0)". "Offset cancel" is performed to offset the sensor zero point.

\* Adjust the force control gain based on the target object. The higher the setting, the higher the response sensitivity to the force command value, however, increasing the value too much may result in vibrations. (See section [8.1.2.9.](#))

## Force Control 2 (Force-Speed Priority Mode Switching)

### ■ Operation details

The robot is moved at a speed of 5 mm/s in the tool Z-direction and pushed with a force of 10 N the moment it collides.

- Force control is started from the PStart position, and the robot is moved in speed priority mode at a speed of 5 mm/s in the tool Z-direction.
- The system detects when the force applies in the force sense coordinate system (tool) +FZt direction reaches 2.5 N or greater, switches to force priority mode, and pushes with a force of 10 N.

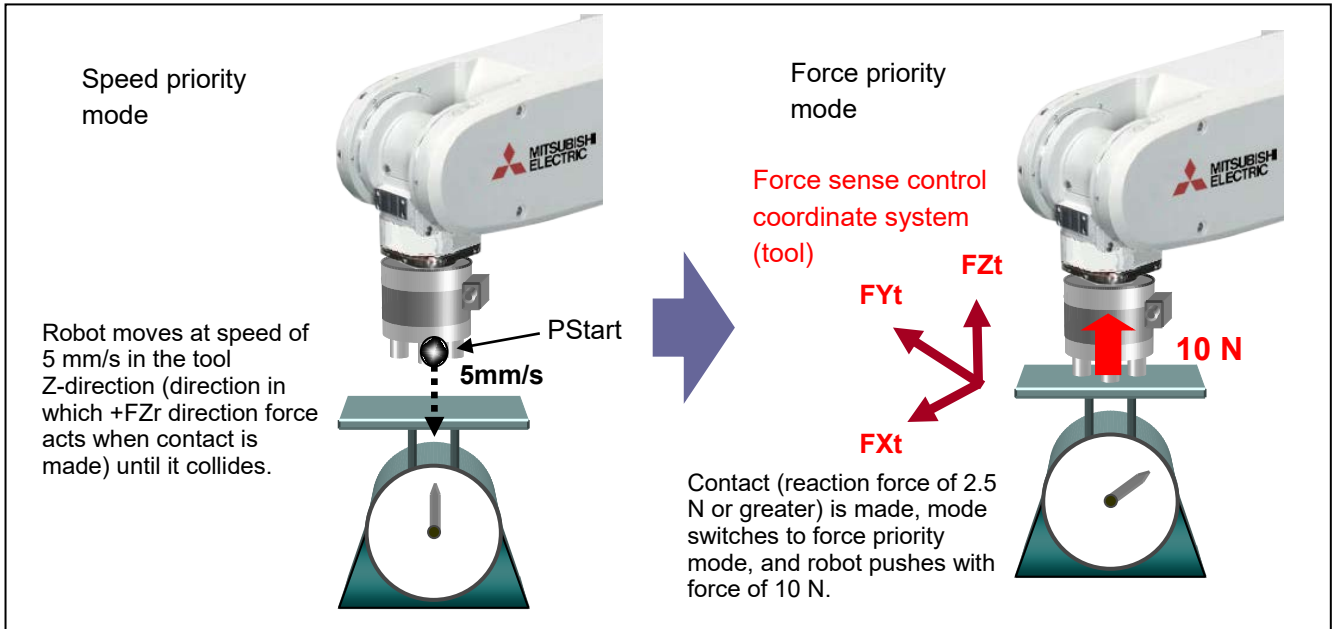

### ■ Program example <Sample program F802.prg>

```

{[Control mode (0)]
P_FsStf0 = (+0.00,+0.00,+0.00,+0.00,+0.00,+0.00)(0,0)
P_FsDmp0 = (+0.00,+0.00,+0.00,+0.00,+0.00,+0.00)(0,0)
P_FsMod0 = (+0.00,+0.00,+1.00,+0.00,+0.00,+0.00)(0,0)
M_FsCod0 = 0
{[Control characteristics (0)]
P_FsGn0 = (+0.00,+0.00,+30.00,+0.00,+0.00,+0.00)(0,0)
P_FsFLm0 = (+0.00,+0.00,+0.00,+0.00,+0.00,+0.00)(0,0)
P_FsFCd0 = (+0.00,+0.00,+10.00,+0.00,+0.00,+0.00)(0,0)
P_FsSpd0 = (+0.00,+0.00,+5.00,+0.00,+0.00,+0.00)(0,0)
P_FsSwF0 = (+0.00,+0.00,+2.50,+0.00,+0.00,+0.00)(0,0)

**** <Force control (force-speed hybrid)> ****
Servo On
Mov PStart
Dly 1
Fsc On,0,0,1
Dly 10
Fsc Off
End

```

'Stiffness coefficient [N/mm] ← No setting required

'Damping coefficient

**'Force sense control mode (Z-axis force control)**

**'Force sense control coordinate system (tool)**

**'Force control gain [ $\mu\text{m}/\text{N}$ ]**

'Force detection setting value [N] ← No setting required

**'Force command**

**'Sets speed control mode speed.**

**'Mode switching judgment value (switch threshold FZt=2.5N)**

'Move to start point.

'Force sense control enabled (drop start with force control)

## ■ Description

- 1) Force sense control is started with the Fsc On command based on the conditions set for "Control mode (0)" and "Control characteristics (0)".
- 2) If the external force is less than the "mode switching judgment value (FZt=2.5N)" specified with the status variable P\_FsSwF0, "speed priority mode" is applied and the robot moves at the speed specified with the status variable P\_FsSpd0. The movement direction is the direction in which the reaction force specified with P\_FsFCd0 can be obtained when contact is made.
- 3) If the external force is equal to or greater than the "mode switching judgment value (FZt=2.5N)", "force priority mode" is applied, and the robot pushes with the force specified with P\_FsFCd0.

## Stiffness Control

### ■ Operation details

Controls the robot softly like a spring with respect to external force applied in the force sense coordinate system (tool)  $\pm F_{Xt}$  and  $\pm F_{Yt}$  directions.

- Stiffness control is specified only for the  $F_{Xt}$  and  $F_{Yt}$  axes. (Position control is specified for all other axes.)
- The robot moves in the direction in which external force is received only on the X and Y planes. The robot moves to its original position when the external force is removed.

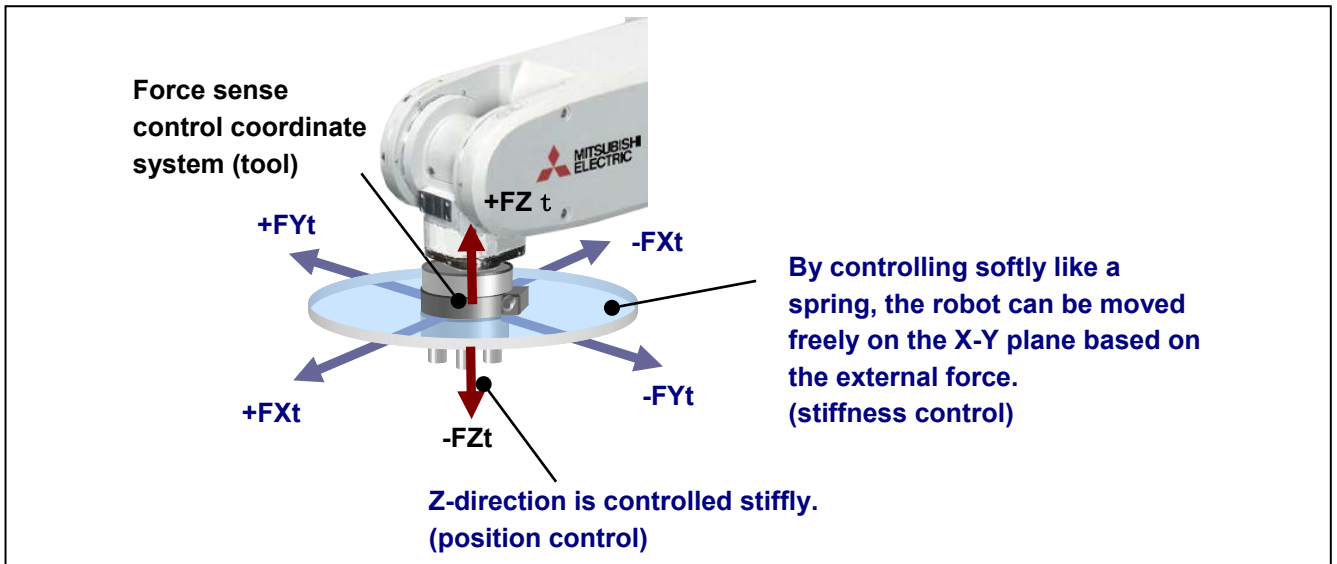

### ■ Program example <Sample program F803.prg>

```
[Control mode (0)]
P_FsStf0 = (+0.10,+0.10,+0.00,+0.00,+0.00,+0.00)(0,0)
P_FsDmp0 = (+0.00,+0.00,+0.00,+0.00,+0.00,+0.00)(0,0)
P_FsMod0 = (+2.00,+2.00,+0.00,+0.00,+0.00,+0.00)(0,0)
M_FsCod0 = 0
[Control characteristics (0)]
P_FsGn0 = (+20.00,+20.00,+0.00,+0.00,+0.00,+0.00)(0,0)
P_FsFLm0 = (+0.00,+0.00,+0.00,+0.00,+0.00,+0.00)(0,0)
P_FsFCd0 = (+0.00,+0.00,+0.00,+0.00,+0.00,+0.00)(0,0)
P_FsSpd0 = (+0.00,+0.00,+0.00,+0.00,+0.00,+0.00)(0,0)
P_FsSwF0 = (+0.00,+0.00,+0.00,+0.00,+0.00,+0.00)(0,0)
*** <Stiffness control (X, Y-axes)> ***
Servo On
Mov PStart
Dly 1
Fsc On, 0, 0, 1 'Force sense enable
Hlt
Fsc Off 'Force sense disable
End
```

'Stiffness coefficient [N/mm]  
'Damping coefficient  
'Force control mode (X, Y-axis stiffness control)  
'Force sense control coordinate system (tool)  
'Force control gain [ $\mu\text{m}/\text{N}$ ]  
'Force detection setting value [N]  
'Force command  
'Sets speed control mode speed.  
'Sets force/speed judgment value.

### ■ Description

- 1) Sets the robot softness with the status variable  $P\_FsStf0$ . The smaller the value, the softer (spring constant is small) the movement.
- 2) Force sense control is started with the `Fsc On` command based on the conditions set for "Control mode (0)" and "Control characteristics (0)". ("Offset cancel" is performed using the `Fsc On` command to offset the sensor zero point.)
- 3) The robot is controlled softly while the operation is interrupted by the `Hlt` command. When the operation is resumed, force sense control is then disabled and normal control mode is applied.

## Control control characteristics Change 1

### ■ Operation details

The push force (control characteristics) is changed during robot movement.

- The robot starts moving from P1 to P2 while pushing with a force of 5.0 N in the Z-direction.
- The push force is increased gradually from areas with operating rate exceeding 50% until a final force of 12.0 N is reached.

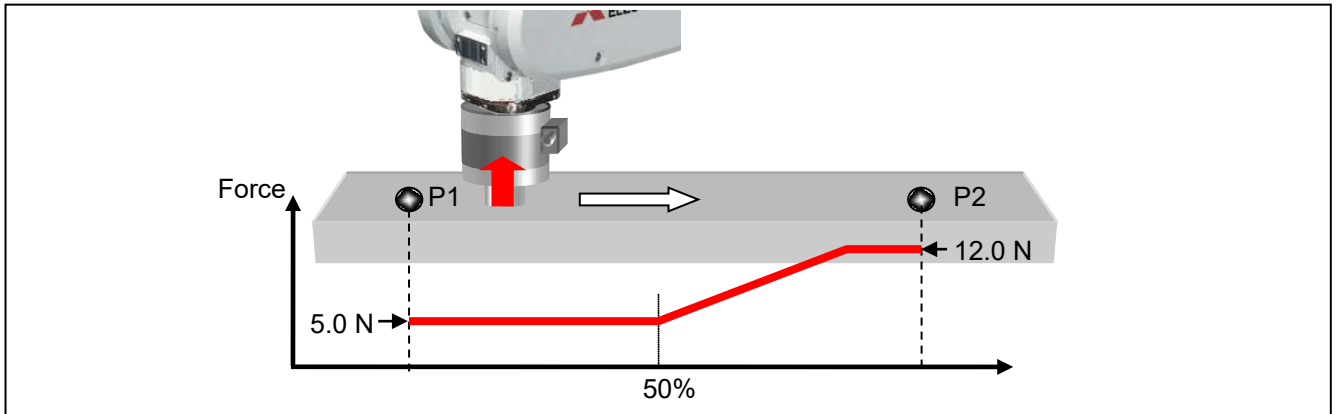

### ■ Program example <Sample program F804.prg>

```

[Control mode (0)]
P_FsStf0 = (+0.00,+0.00,+0.00,+0.00,+0.00,+0.00)(0,0)      'Stiffness coefficient [N/mm]
P_FsDmp0 = (+0.00,+0.00,+0.00,+0.00,+0.00,+0.00)(0,0)    'Damping coefficient
P_FsMod0 = (+0.00,+0.00,+1.00,+0.00,+0.00,+0.00)(0,0)    'Force sense control mode (Z-axis force control)
M_FsCod0 = 0                                             'Force sense control coordinate system (tool)
[Control characteristics (0)]
P_FsGn0 = (+0.00,+0.00,+4.00,+0.00,+0.00,+0.00)(0,0)    'Force control gain [μm/N]
P_FsFLm0 = (+0.00,+0.00,+0.00,+0.00,+0.00,+0.00)(0,0)    'Force detection setting value [N]
P_FsFCd0 = (+0.00,+0.00,+5.00,+0.00,+0.00,+0.00)(0,0)  'Force command
P_FsSpd0 = (+0.00,+0.00,+0.00,+0.00,+0.00,+0.00)(0,0)    'Sets speed control mode speed.
P_FsSwF0 = (+0.00,+0.00,+0.00,+0.00,+0.00,+0.00)(0,0)    'Sets force/speed judgment value.
[Control characteristics (-1)]
P_FsGn1 = (+0.00,+0.00,+4.00,+0.00,+0.00,+0.00)(0,0)    'Force control gain [μm/N]
P_FsFLm1 = (+0.00,+0.00,+0.00,+0.00,+0.00,+0.00)(0,0)    'Force detection setting value [N]
P_FsFCd1 = (+0.00,+0.00,+12.00,+0.00,+0.00,+0.00)(0,0) 'Force command
P_FsSpd1 = (+0.00,+0.00,+0.00,+0.00,+0.00,+0.00)(0,0)    'Sets speed control mode speed.
P_FsSwF1 = (+0.00,+0.00,+0.00,+0.00,+0.00,+0.00)(0,0)    'Sets force/speed judgment value.
**** <Force control (control characteristics change)> ****
Spd 10
Servo On
Mvs P1, -3          'Moves to position 3 mm over contact position.
Dly 1
Fsc On, 0, 0, 1   'Force sense control enable
Dly 3
FsGChg 50,500, -1 'Set so that control characteristics changes to -1 at 50% position. (Change time: 500 ms)
Mvs P2
Fsc Off 'Force sense disable
End

```

■ Description

- 1) After the robot moves to the position 3 mm over the contact position, wait for 1 s until the robot comes to a complete stop.
- 2) Force sense control (force control) is started with the Fsc On command.
- 3) The control characteristics change conditions are specified with the FsGChg command. In this sample program, the control characteristics setting is changed gradually from "0" to "-1" over a period of 500 ms when the movement command position reaches the point between the movement start position and movement end position.
- 4) The control characteristics change starts at the midpoint (50% position) while moving to P2, and the force command value is increased gradually.



## Control characteristics Change 2 (Mo Trigger)

### ■ Operation details

The robot moves while following a guide gauge.

- Movement is started in the +Y-direction at a speed of 10 mm/s while pushing in the -X direction with a force of 5 N.
- Contact with the +Y-direction wall surface is detected at position A, and robot movement changes to the +X-direction at a speed of 10 mm/s while pushing in the +Y direction with a force of 5 N.
- Movement stop when contact with the +X-direction wall surface is detected at position B.

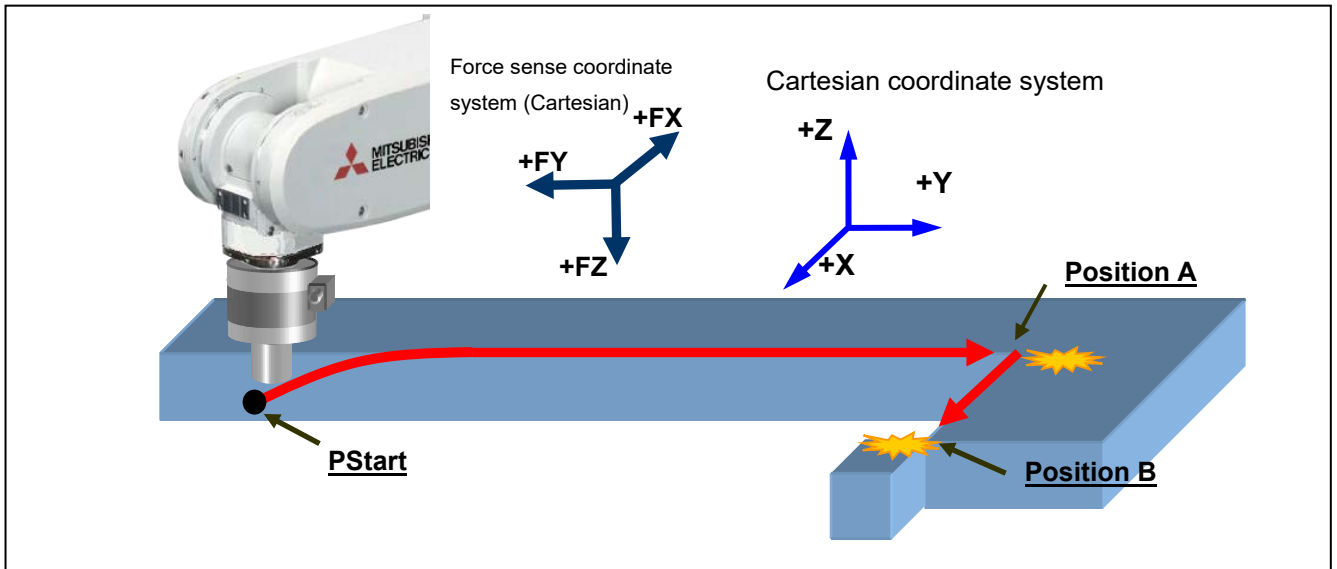

### ■ Program example <Sample program F805.prg>

<code>[Control mode (0)]</code>	
<code>P_FsStf0 = (+0.00,+0.10,+0.00,+0.00,+0.00,+0.00)(0,0)</code>	'Stiffness coefficient [N/mm]
<code>P_FsDmp0 = (+0.00,+0.00,+0.00,+0.00,+0.00,+0.00)(0,0)</code>	'Damping coefficient
<code>P_FsMod0 = (+1.00,+1.00,+0.00,+0.00,+0.00,+0.00)(0,0)</code>	'Force sense control mode (X, Y-axis force control)
<code>M_FsCod0 = 1</code>	'Force sense control coordinate system (XYZ)
<code>[Control characteristics (0)]</code>	
<code>P_FsGn0 = (+2.00,+2.00,+0.00,+0.00,+0.00,+0.00)(0,0)</code>	'Force control gain [ $\mu\text{m}/\text{N}$ ]
<code>P_FsFLm0 = (+0.00,+0.00,+0.00,+0.00,+0.00,+0.00)(0,0)</code>	'Force detection setting value [N]
<code>P_FsFCd0 = (-5.00,+5.00,+0.00,+0.00,+0.00,+0.00)(0,0)</code>	'Force command
<code>P_FsSpd0 = (+0.00,+10.00,+0.00,+0.00,+0.00,+0.00)(0,0)</code>	'Sets speed control mode speed.
<code>P_FsSwF0 = (+0.00,+3.00,+0.00,+0.00,+0.00,+0.00)(0,0)</code>	'Sets force/speed judgment value.
<code>[Control characteristics (-1)]</code>	
<code>P_FsGn1 = (+2.00,+2.00,+0.00,+0.00,+0.00,+0.00)(0,0)</code>	'Force control gain [ $\mu\text{m}/\text{N}$ ]
<code>P_FsFLm1 = (+0.00,+0.00,+0.00,+0.00,+0.00,+0.00)(0,0)</code>	'Force detection setting value [N]
<code>P_FsFCd1 = (+5.00,+5.00,+0.00,+0.00,+0.00,+0.00)(0,0)</code>	'Force command
<code>P_FsSpd1 = (+10.00,+0.00,+0.00,+0.00,+0.00,+0.00)(0,0)</code>	'Sets speed control mode speed.
<code>P_FsSwF1 = (+3.00,+0.00,+0.00,+0.00,+0.00,+0.00)(0,0)</code>	'Sets force/speed judgment value.
<code>**** &lt;Force control-force direction change&gt; ****</code>	
<code>Def MoTrg 1, P_FsCurD.Y&gt;4.5</code>	'Mo trigger 1 definition: Force sensor data $F_y > 4.5\text{N}$
<code>Mvs PStart</code>	'Moves to start position.
<code>Dly 1</code>	'Wait until robot completely stopped.
<code>Fsc On, 0, 0, 1</code>	'Force sense enable
<code>FsCTrg 1, 100, -1, 30, 0, 1</code>	'Specify control characteristics change with Mo trigger.
<code>*LBL1: If P_FsCurD.X &lt; 4.5 Then GoTo *LBL1</code>	
<code>Fsc Off</code>	'Force sense disable
<code>End</code>	

■ Description

- 1) Changes the control characteristics (force command direction, speed command when in speed priority mode) when the conditions specified for the Mo trigger are established using the FsCTrg command. (See section [8.2.1](#) for details on the Mo trigger.)
- 2) The Mo trigger is defined with the Def MoTrg command. In this example, Mo trigger condition 1 is established when  $F_y > 4.5 \text{ N}$  is satisfied.
- 3) After moving to PStart, force control is started with the < Control characteristics (0)> conditions using the Fsc On command. The force direction and movement direction at this time are as follows.

Axis Direction	Movement Direction
X	Moves to the position where reaction force of $F_x = -5 \text{ N}$ can be obtained.
Y	Moves to the position where reaction force of $F_y = +5 \text{ N}$ can be obtained. However, if the reaction force is less than 3 N, the robot moves in speed priority mode to achieve a speed of 10 mm/s.
Z	No movement

- 4) When Mo trigger condition 1 is established (when position A is reached) with the FsCtrg command, the control characteristics is changed from "0" to "-1". The movement direction at this time is as follows. (The FsCtrg command has a timeout function, allowing an error to be generated if conditions are not established within the specified time.)

Axis Direction	Movement Direction
X	Moves to the position where reaction force of $F_x = +5 \text{ N}$ can be obtained. However, if the reaction force is less than 3 N, the robot moves in speed priority mode to achieve a speed of 10 mm/s.
Y	Moves to the position where reaction force of $F_y = +5 \text{ N}$ can be obtained.
Z	No movement

- 5) The system waits until position B is reached ( $F_x \geq 4.5 \text{ N}$ ) using the If command, and force sense control is then stopped.

## 8.2 Force Sense Detection

The force sense detection function detects the robot contact status using force sensor information. By using this function, applications with high degree of freedom can be constructed in MELFA-BASIC V to detect contact during movement, change the movement direction, detect work failures, and perform retry operation or error processing and so on.

### <Features>

- 1) Trigger conditions combining force data and position data can be set. (Mo trigger)
- 2) Interrupt processing for start-up and shut-down conditions can be performed for force sensor data force detection setting values (set with Fsc On command conditions group (control characteristics)).
- 3) Sensor data and position data obtained when the force detection setting value is exceeded can be retained as status variables.
- 4) Current and maximum force sensor data values can be referenced.

Status variables for the force sense detection function are as follows.

**Table 8-9: Force detection related status variables**

Class	Status Variable	Function Overview
Mo trigger	M_MoTrg	Checks the Mo trigger status.
Force detection status	M_FsLmtS	Checks whether the force sensor data force detection setting value has been exceeded.
	P_FsLmtR	Checks the status of the current force sensor data with respect to the force sensor data force detection setting value.
Data latch	P_FsLmtX	Checks/resets axes for which the force sensor data force detection setting value is exceeded.
	P_FsLmtP	Checks/resets the robot FB position when the force sensor data force detection setting value is exceeded.
	P_FsLmtD	Checks/resets the force sensor data when the force sensor data force detection setting value is exceeded.
Data referencing	P_FsMaxD	Checks/resets the force sensor maximum data value during force sense control.
	P_FsCurD	Checks the current force sensor data.
	P_FsCurP	Checks the current position command offset with force sense control.
	M_FsRsltF	Checks the current force sensor resultant force.
	M_FsRsltM	Checks the current force sensor resultant moment.
	M_FsCSts	Checks the force sense control enabled/disabled status.

- Refer to section [8.1.2](#) for details on force setting values.
- Refer to section [11.3](#) for details on status variables.

## 8.2.1 Mo Trigger

The Mo trigger function is used to issue trigger signals when conditions are established based on conditions defined by combining the following data with a comparison operation. The Mo trigger status is output to status variable M\_MoTrg.

Data	Description
Each P_Curr component	Robot current position (linear data)
Each P_Fbc component	Robot FB position (linear data)
Each J_Curr component	Robot current position (joint data)
Each J_Fbc component	Robot FB position (joint data)
Each P_FsCurP component	Position command after offsetting with force control
Each P_FsCurD component	Force sensor data (values after updating offset cancel, converting tool/XYZ coordinates)
M_FsRsltF	Force sensor data resultant force (values after updating offset cancel, converting tool/XYZ coordinates)
M_FsRsltM	Force sensor data resultant moment (values after updating offset cancel, converting tool/XYZ coordinates)
M_In	Input signal ON/OFF status
M_Out	Output signal ON/OFF status

By using this function, complicated trigger conditions can be specified for use with work completion judgment/interrupt processing when abnormal work is performed (DEF ACT command), and for changing force sense control characteristics (FsCTrg command), and so on.

To use the Mo trigger, define trigger conditions with the following procedure, and then start condition monitoring.

<Mo trigger setting procedure flow>

- (1) Define trigger conditions with the Def MoTrg command. Up to three types of conditions can be set.
- (2) Enable the Mo trigger with the SetMoTrg command.
- (3) Perform condition branching and interrupt processing using values output to status variable M\_MoTrg.

\* Procedures (2) and (3) are unnecessary if using FsCTrg command.

Refer to " Chapter [11](#) Language Specifications " for details on each command.

### Def MoTrg (Def Mo trigger)

#### [Function]

Defines trigger conditions (Mo trigger) that reference position commands and the FB position, as well as force sensor data and so on.

#### [Syntax]

```
Def □ MoTrg □ <Trigger No.>, <Conditions>
```

#### [Terminology]

<Trigger No.> Specifies the defined Mo trigger No. with a constant.

Setting range: 1 to 3

<Conditions> Conditions under which the Mo trigger turns ON are described with the following syntax.

<Specification data> <Comparison operator> <Numerical data>

<Specification data> The following robot (system) status variables can be used.

- Status variables  
All components of P\_Curr, P\_Fbc, J\_Curr, J\_Fbc, P\_FsCurP, P\_FsCurD, M\_FsRsltF, M\_FsRsltM
- Input signal M\_In
- Output signal M\_Out

<Numerical data> The following constants and variables can be used.

- Numeric constants, numeric variables, numeric array variables
- Position variable component data
- Joint variable component data

\* Up to four types of <Conditions> can be combined and used with And and Or operators.

[Example: (<Condition A> And <Condition B>) Or (<Condition C> And <Condition D>)]

### SetMoTrg (Set Mo trigger)

#### [Function]

Enables/disables trigger conditions (Mo trigger) that reference position commands and the FB position, as well as force sensor data and so on.

#### [Syntax]

```
SetMoTrg □ <Trigger No.>
```

#### [Terminology]

<Trigger No.> Specifies the trigger No. for the Mo trigger to be enabled with a constant.

If 0 is specified, the Mo. Trigger is disabled.

Setting range: 0 - 3

M MoTrg

[Function]

References the Mo trigger enabled/disabled status, and the enabled trigger ON/OFF status.

[Syntax]

Example) <Numerical variable> = M\_MoTrg (<Trigger No.>)

Value	Details		
	Defined/Undefined Status	Enabled/Disabled Status	Trigger ON/OFF Status
+1	Defined	Enabled	ON
0	Defined	Enabled	OFF
-1	Defined	Disabled	---
-2	Undefined	---	---

## 8.2.2 Force Detection Status

### M FsLmtS

Status variable M\_FsLmtSw checks whether the force detection setting value specified with the " control characteristics " group has been exceeded. It can be used for interrupt processing and so on when a collision occurs.

(Refer to section [11.3](#) for details on status variables.)

### P FsLmtR

Status variable P\_FsLmtR outputs the status for each axis based on the force detection setting value specified with the " control characteristics " group.

(Refer to section [11.3](#) for details on status variables.)

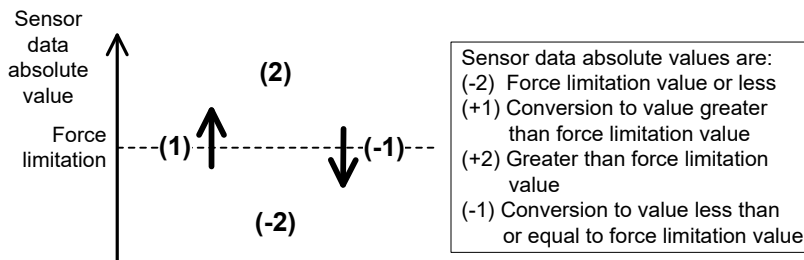

<Example 1>:

When the force in the X-direction exceeds the force detection setting value, the next command is skipped with an interrupt.

```
Mvs P2 Wthif P_FsLmtR . X = 1, Skip
```

< Example 2>:

When the force in the Z-direction becomes smaller than the force detection setting value, this status variable defines that interrupt processing is executed.

```
M1=-1
Def Act 1, P_FsLmtR.Z=M1 GoTo *PCEN, S
```

## 8.2.3 Data Latch

### P FsLmtX / P FsLmtP / P FsLmtD

Axis data, position data, and force sense data at the point the force sensor "force detection setting value" is exceed is latched in status variables P\_FsLmtX( ), P\_FsLmtP( ), and P\_FsLmtD( ).

(Refer to section [11.3](#) for details on status variables.)

## 8.2.4 Data Referencing

### P FsMaxD / P FsCurD

The force sense data maximum and current values are stored in status variables P\_FsMaxD( ) and P\_FsCurD( ).

(Refer to section [11.3](#) for details on status variables.)

## 8.2.5 Usage Example (Force Sense Detection)

### Interrupt Processing (M\_FsLmtS)

#### ■ Operation details

Abnormal force is detected at times of collision and the robot comes to an emergency stop.

- The force detection status is constantly monitored, and when contact is made, the robot is stopped swiftly and interrupt processing is executed.



#### ■ Program example <Sample program F806.prg>

```

'[Control mode (0)]
P_FsStf0 = (+0.00,+0.00,+0.00,+0.00,+0.00,+0.00)(0,0)      'Stiffness coefficient [N/mm]
P_FsDmp0 = (+0.00,+0.00,+0.00,+0.00,+0.00,+0.00)(0,0)    'Damping coefficient
P_FsMod0 = (+0.00,+0.00,+0.00,+0.00,+0.00,+0.00)(0,0)    'Force control mode (All axis position control)
M_FsCod0 = 0                                               'Force sense control coordinate system (tool)
'[Control characteristics (0)]
P_FsGn0 = (+0.00,+0.00,+0.00,+0.00,+0.00,+0.00)(0,0)    'Force control gain [μm/N]
P_FsFLm0 = (+50.00,+50.00,+50.00,+0.50,+0.50,+0.50)(0,0) 'Force detection setting value [N]
P_FsFCd0 = (+0.00,+0.00,+0.00,+0.00,+0.00,+0.00)(0,0)    'Force command
P_FsSpd0 = (+0.00,+0.00,+0.00,+0.00,+0.00,+0.00)(0,0)    'Sets speed control mode speed.
P_FsSwF0 = (+0.00,+0.00,+0.00,+0.00,+0.00,+0.00)(0,0)    'Sets force/speed judgment value.
**** <Interrupt> ***
Def Act 1, M_FsLmtS=1 GoTo *XERR, F
Spd 10
Fsc On, 0, 0, 1                                           'Force sense enable (offset cancel designation)
Act 1=1                                                    ' Act 1 is enabled.
Mvs P1                                                    '
Fsc Off                                                  'Force sense disable
End
*XERR
Act 1=0                                                      ' Act 1 is disabled.
Error 9100                                                    'Error occurrence
End

```

#### ■ Description

When the force/moment exceeds the force detection setting value specified with the status variable P\_FsFLm0, the status variable M\_FsLmtS value changes from 0 to 1. By using this status variable M\_FsLmtS as an interrupt signal, error processing can be performed when unnecessary force acts on the workpiece or sensor, and interrupt processing can be performed when a contact judgment/work failure occurs.



## Interrupt Processing (Mo Trigger)

### ■ Operation details

The push force and position are inspected simultaneously, and the quality of the work is judged.

- Work is judged as being successful if the Z coordinate is less than 5 mm, and a reaction force greater than 18 N is detected in the FZt direction.
- If the above conditions are not satisfied within 5 seconds of assembly, assembly is judged as having failed, and an error is output.

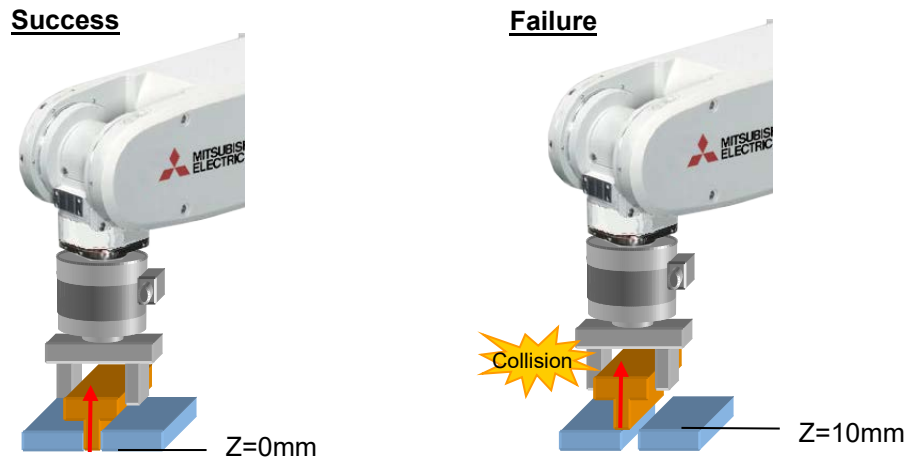

### ■ Program example <Sample program F807.prg>

[Control mode (0)]	
P_FsStf0 = (+0.00,+0.00,+0.00,+0.00,+0.00,+0.00)(0,0)	'Stiffness coefficient [N/mm]
P_FsDmp0 = (+0.00,+0.00,+0.00,+0.00,+0.00,+0.00)(0,0)	'Damping coefficient
P_FsMod0 = (+2.00,+2.00,+1.00,+0.00,+0.00,+0.00)(0,0)	'Force control mode (X,Y: stiffness control, Z: force control)
M_FsCod0 = 0	'Force sense control coordinate system (tool)
[Control characteristics (0)]	
P_FsGn0 = (+2.00,+2.00,+2.00,+0.00,+0.00,+0.00)(0,0)	'Force control gain [ $\mu\text{m}/\text{N}$ ]
P_FsFLm0 = (+0.00,+0.00,+0.00,+0.0,+0.0,+0.0)(0,0)	'Force detection setting value [N]
P_FsFCd0 = (+0.00,+0.00,+20.00,+0.00,+0.00,+0.00)(0,0)	'Force command
P_FsSpd0 = (+0.00,+0.00,+0.00,+0.00,+0.00,+0.00)(0,0)	'Sets speed control mode speed.
P_FsSwF0 = (+0.00,+0.00,+0.00,+0.00,+0.00,+0.00)(0,0)	'Sets force/speed judgment value.
*** <Interrupt> ***	
Def MoTrg 1, ((P_Fbc.Z <= 5) AND (P_FsCurD.Z > 18))	'Work complete conditions defined for Mo trigger 1.
Def Act 1,M_MoTrg(1)=1 GoTo *XOK,F	'Mo trigger 1 defined as interrupt condition.
Mvs PStart	'Robot moves over insertion position.
SetMoTrg 1	'Mo trigger 1 is enabled.
Fsc On,0,0,1	'Force sense control is enabled. (Insertion started with force control.)
Act 1=1	'Interrupt processing 1 is enabled.
M_Timer(1)=0	'Timer clear
*LBL1: If M_Timer (1) < 5000 Then GoTo *LBL1	'Waits for timeout time of 5 seconds.
Fsc Off	'Force sense control is disabled.
Error 9100	'Error occurs if insertion work not complete within 5 seconds.
End	
*XOK	'Insertion work complete interrupt processing
Act 1=0	
SetMoTrg 0	'Mo trigger is enabled.
Fsc Off	'Force sense control is disabled.
HOpen 1	
P2=P_Fbc	'Feedback position acquisition
P2.Z=P2.Z+100	'Target position determined as position +100 mm in Z-direction

from current position

Mvs P2

End

■ Description

- 1) Work complete conditions are defined for Mo trigger 1 with the Def MoTrg command.
- 2) Force sense control is enabled after enabling Mo trigger 1, and insertion work is started.
- 3) If insertion work is not complete within 5 seconds of work starting, a 9100 error is output, and insertion work is stopped.
- 4) If insertion work is successfully completed, M\_MoTrg(1)=1, and interrupt processing (label: \*XOK) is performed.

## Data Latch/Data Referencing

### ■ Operation details

Position data and force data during push movement is latched, and the spring part spring constant is calculated.

- Data is set to that position and force data is saved at the point  $FZt=10\text{ N}$  is exceeded. (Data latch function)
- The robot is moved to the final push position, and the spring constant is calculated from the current position and force data and data obtained with the data latch function.

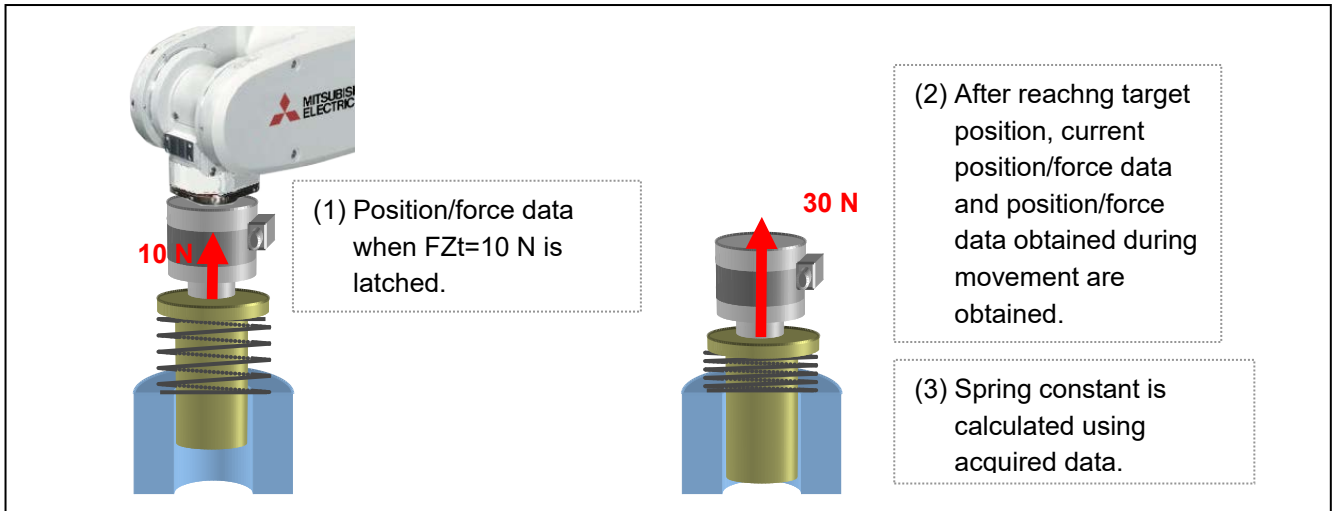

### ■ Program example <Sample program F808.prg>

```

[Control mode (0)]
P_FsStf0 = (+0.00,+0.00,+0.00,+0.00,+0.00,+0.00)(0,0)      'Stiffness coefficient [N/mm]
P_FsDmp0 = (+0.00,+0.00,+0.00,+0.00,+0.00,+0.00)(0,0)    'Damping coefficient
P_FsMod0 = (+0.00,+0.00,+0.00,+0.00,+0.00,+0.00)(0,0)    'Force control mode (all axis position control)
M_FsCod0 = 0                                                'Force sense control coordinate system (tool)

[Control characteristics (0)]
P_FsGn0 = (+0.00,+0.00,+0.00,+0.00,+0.00,+0.00)(0,0)    'Force control gain [ $\mu\text{m}/\text{N}$ ]
P_FsFLm0 = (+200.00,+200.00,+10.00,+7.0,+7.0,+7.0)(0,0)  'Force detection setting value [N]
P_FsFCd0 = (+0.00,+0.00,+0.00,+0.00,+0.00,+0.00)(0,0)    'Force command
P_FsSpd0 = (+0.00,+0.00,+0.00,+0.00,+0.00,+0.00)(0,0)    'Sets speed control mode speed.
P_FsSwF0 = (+0.00,+0.00,+0.00,+0.00,+0.00,+0.00)(0,0)    'Sets force/speed judgment value.

*** <Spring constant calculation> ***
Mvs PStart                                                  'Robot moves above start position.
Spd 10
Fsc On,0,0,1                                               'Force sense control is enabled. (push start with force control)
Fine 100                                                    'Robot waits until positioning movement is complete.
Mvs PEnd
MFD=P_FsCurD.Z-P_FsLmtD.Z                                  'Force displacement calculation (N)
MPD=Abs(P_Fbc.Z-P_FsLmtP.Z)                                'Spring displacement calculation (mm)
MSR=MFD/MPD                                                 'Spring constant is calculated (N/mm).
Fsc Off                                                     ' Force sense control is disabled.
End

```

■ Description

- 1) The force detection setting value is set and force control is enabled so that the position/force data are latched when  $FZt=10$  N.
- 2) The robot is moved slowly to position PEnd at the speed of 10 mm/s and the spring is pushed.
- 3) Each of the position/force data at the moment the spring reaction force at the spring push process exceeds 10 N is saved to status variables P\_FsLmtP and P\_FsLmtD.
- 4) The current position/force data (P\_Fbc, P\_FsCurD) when the target position is reached is read, the amount of change from data saved during the movement is calculated, the spring constant is calculated, and then saved to variable MSR. (In this example, calculation is performed based on the assumption that the reaction force at the target position is sufficiently greater than 10 N.)

## 8.3 Force Sense log

The force sense log function is used to obtain and display log data such as force sensor data and position data. Log data can be viewed in a graph using the RT ToolBox2 force sense control log file viewer. This function can be used for such tasks as force sense control related parameter adjustments and checking the work status. Furthermore, this function is equipped with a feature to transfer force sense log files to the computer by FTP, facilitating robot quality control during operation by checking work quality and analyzing data when errors occur.

### 8.3.1 Force Sense Log Function Specifications

Table 8-10: Force sense log function specifications

Function	Item		Description
Force sense log data acquisition	Acquirable data		See Table 8-11
	Sample time		7.111 ms cycles
	Max. data acquisition time		45 sec.*1
	Data acquisition trigger		Log data is acquired from the time the FsLog On command is executed until the FsLog Off command is executed.
	Data file format		CSV format (See Table Table 8-12.)
	No. of saved data files		2 *2 (Saved data is lost when the controller power is turned OFF.)
Force sense log data display (RT ToolBox2)	Graph display	Graph format	Scatter diagram format <Horizontal axis> Select from time, position commands, position FB, movement ratio. <Display data> Select from force sensor data, position commands, position FB, current FB.
		Display data qty	Vertical axis: 6, horizontal axis: 1
	Data processing		Filter processing (Filter processing is only possible for force sensor data.)
	Data operation		Force sense control log file reading from R/C
			Graph image backup
Force sense log file FTP transfer	Data transfer		Log files are saved to computer using FTP.

\*1: If the Max. data acquisition time (45 s) is reached before the FsLog Off command is executed, data collection is automatically stopped.

\*2: If the number of files stored in the controller exceeds 2, the file with oldest creation data is deleted.

Table 8-11: Collected data

Collected Data	Unit	Supplementary Information
Force sensor data	[N] or [Nm]	Set with parameter FSLOGFN from the following: <ul style="list-style-type: none"> <li>• Force sensor raw data (with offset cancel)</li> <li>• Force sensor raw data (without offset cancel)</li> <li>• Data after coordinate conversion (with offset cancel)</li> </ul> Fx, Fy, Fz, Mx, My, Mz
Position command	[mm] or [deg]	Command position Cmd-X, Cmd-Y, Cmd-Z, Cmd-A, Cmd-B, Cmd-C, Cmd-L1, Cmd-L2, Cmd-FL1, Cmd-FL2
Position FB	[mm] or [deg]	Feedback position FB-X, FB-Y, FB-Z, FB-A, FB-B, FB-C, FB-L1, FB-L2, FB-FL1, FB-FL2
Current FB	0.1%(Rated current ratio)	Motor current for each axis iFB-J1, iFB-J2, iFB-J3, iFB-J4, iFB-J5, iFB-J6, iFB-J7, iFB-J8

Table 8-12: Log file format (CSV)

```

Log File Version,1.0
Time Stamp,YYYY.MM.DD HH:MM:SS
Mecha No.,1
Robot Name,*****
Data Sampling,7.111ms
Sensor Data Type,2
Offset Cancel,-18.319,3.110,97.473,0.230,1.834,-0.787
Tool Data,0.000,0.000,0.000,0.000,0.000,0.000
Base Data,0.000,0.000,0.000,0.000,0.000,0.000
No.,Fx,Fy,...,Mz,Cmd-X,Cmd-Y,...,Cmd-FL2,FB-X,FB-Y,...,FB-FL2,iFB-J1,iFB-J2,...,iFB-J8
0,0.000,0.000,...,0.000,0.000,0.000,...,0.000,0.000,...,0.000,0.000,...,0.000
1,0.000,0.000,...,0.000,0.000,0.000,...,0.000,0.000,...,0.000,0.000,...,0.000
2,0.000,0.000,...,0.000,0.000,0.000,...,0.000,0.000,...,0.000,0.000,...,0.000
:
:

```

#### ■□■ Base/tool conversion ■□■

- "Position commands" and "position FB" data are output in a coordinate system based on the tool/base conversion data specified when executing the PsLog Off command. (The applied tool/base conversion data is described at the beginning of the log file.)
- If the data is switched between tool and base or vice versa during log data collection, the position command/position FB before the change is not saved as a log file.

## 8.3.2 Parameter Settings

Parameter settings relating to the force sense log function are as follows.

It is necessary to set parameter FSLOGFN in order to use the force sense log function.

(Settings can be specified efficiently using the parameter editing screen discussed in sections [12.2](#) or [12.3](#).)

**Table 8-13: Force sense log related parameter list**

Parameter	Parameter Name	No. of Elements	Description	Default Factory Setting
Log function	FSLOGFN	3 integers	<p>Specifies settings for the force sense log function.</p> <p>1st element: Enables/disabled the log function. [Setting range] 0 (disable), 1 (enable)</p> <p>2nd element: Selects the collected force sensor data type. [Setting range] 0: Raw data (with offset cancel) 1: Raw data (without offset cancel) 2: Data after coordinate conversion (offset cancel designation updated)</p> <p>3rd element: Specifies whether to use/not use FTP. [Setting range] 0 (Do not use), 1 (Use)</p>	0, 2, 0
Log data transfer	FTPID	1 character string	<p>Sets the user ID used with FsOutLog command FTP communication.</p> <p>1st element: user ID Setting rang: Up to 8 single-byte alphanumeric characters (upper/lower case)</p>	ftpuser
	FTPPASS	1 character string	<p>Sets the password used with FsOutLog command FTP communication.</p> <p>1st element: password [Setting range] Up to 16 single-byte alphanumeric characters (upper/lower case), or single-byte symbols (! # \$ % &amp; = - @ . ? _)</p>	ftppassword
	FTPSVRIP	1 character string	<p>Sets the FTP server IP address used with FsOutLog command FTP communication.</p> <p>1st element: IP address [Setting range] "0.0.0.0" to "255.255.255.255"</p>	192.168.0.99

### 8.3.3 Force Sense Log Data Acquisition

Robot language MELFA-BASIC V FsLog On and FsLog Off commands are used to specify the start and end of log data acquisition. When the FsLog Off command is executed, a log file with specified file No. name is generated.

(Refer to section "[11.5](#)" for details on language specifications.)

#### FsLog On

[Function]

Starts force sensor data and position command, position FB, and current FB value logging.

[Syntax]

FsLog □ On

#### FsLog Off

[Function]

Ends force sensor data and position command, position FB, and current FB value logging.

[Syntax]

FsLog □ Off <Log File No.>

[Terminology]

<Log File No.> Specifies the log file No. containing collected data.  
Setting range: 1 to 999999999



### 8.3.4 Force Sense Log Data Display (RT ToolBox2)

The method used to display force sense log data in a graph using the RT ToolBox2 force sense control log file viewer function is described below.

#### 8.3.4.1 Start Method

Select [Tools] → [Force Sense Control Log File Viewer] in the RT ToolBox2 workspace to display the force sense control log file viewer screen.

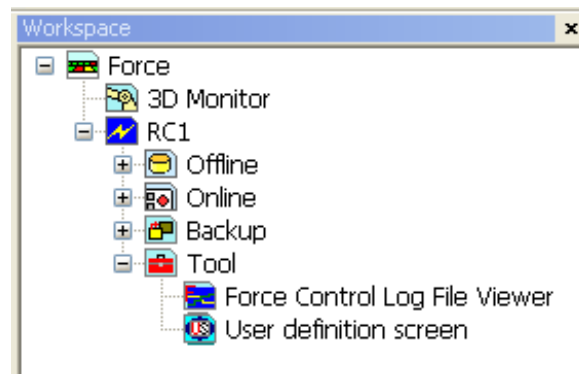

Fig. 8-1: Start method when using force sense control log file viewer

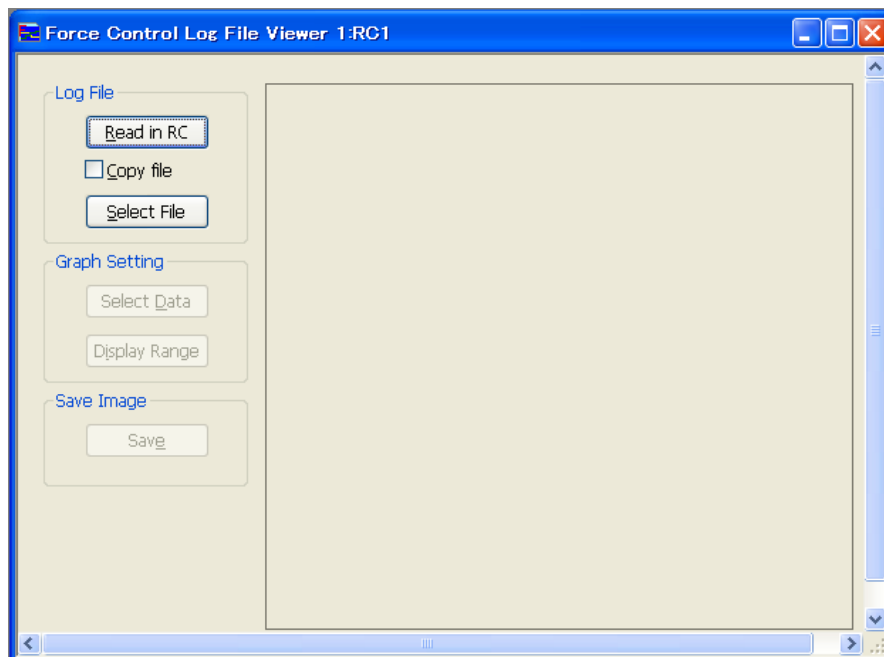

Fig. 8-2: Force sense control log file viewer main screen

### 8.3.4.2 Main Screen

Log files are imported and displayed in a graph using the buttons on the force sense control log file viewer main screen. A description of each button is given below.

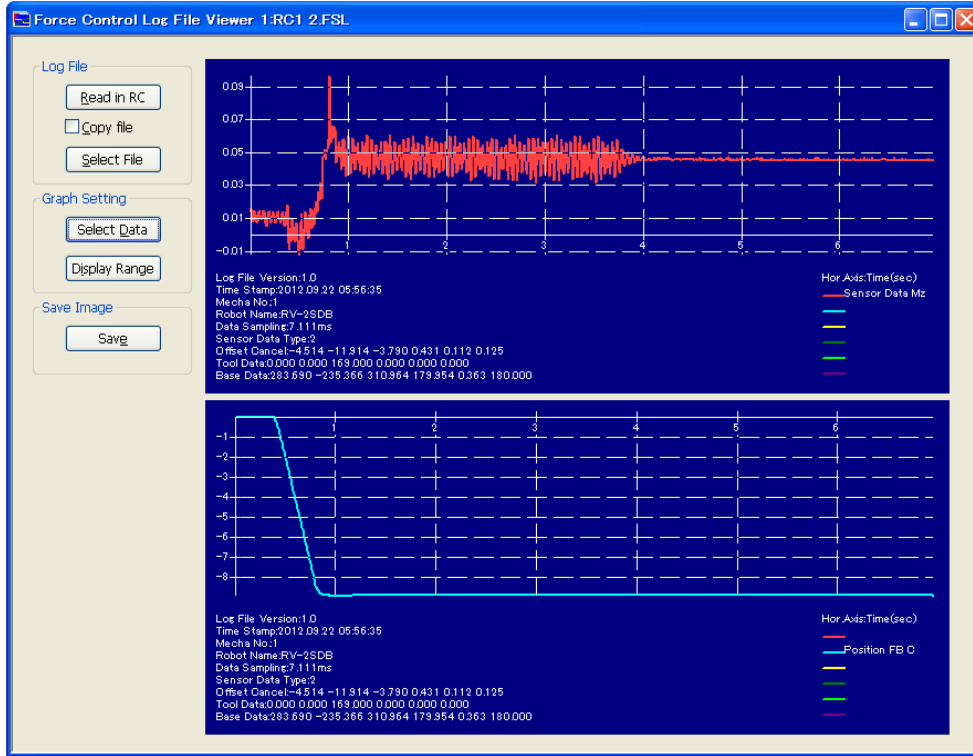
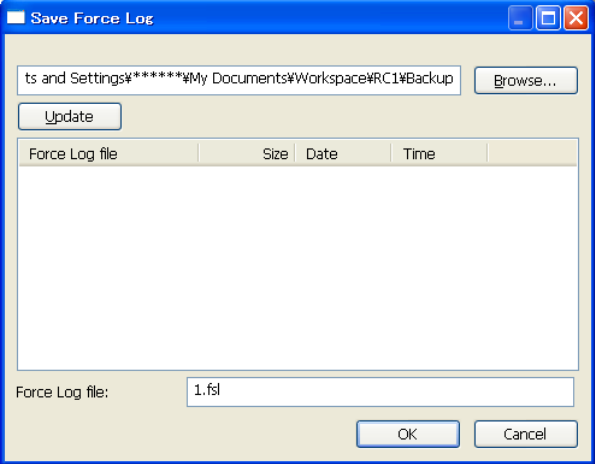
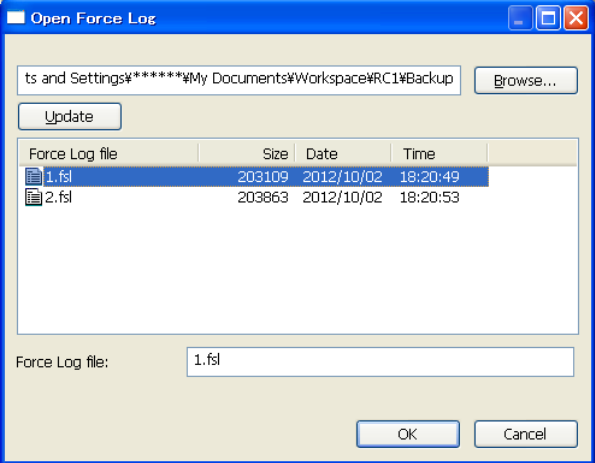

Fig. 8-3: Image of force sense control log file viewer main screen

Table 8-14: Main screen description

No.	Item	Description
(1)	[Read RC] button	<p>By pressing this button when the R/C (robot controller) is connected online, the following screen appears, allowing the user to read log files selected from a log file list to the computer.</p>

No.	Item	Description
		<p>By pressing the [Read RC] button and reading a log file with the [Copy File] check box selected, a log file save screen appears after reading the log file.</p> <p>Specify the file save destination and file name, and then click [OK] to save the read log file to the computer.</p> 
(2)	[Select File] button	<p>By pressing this button, the following screen appears, allowing the user to read log files selected from the log file list.</p> 
(3)	[Select Data] button	<p>Displays a "Data Selection Screen" used for displaying data in a graph. This button can be used after selecting a log file. (See " <a href="#">8.3.4.3 Data Selection Screen</a> ".)</p>
(4)	[Display Range] button	<p>Displays a screen used to set the maximum and minimum values for the graph horizontal and vertical axes. This button can be used after selecting a log file. (See " <a href="#">8.3.4.4 Display Range Setting Screen</a> ".)</p>
(5)	[Save] button	<p>Converts content in the display area to a bitmap file and saves it to the computer.</p>

### 8.3.4.3 Data Selection Screen

Selects data displayed at the following Data Selection screen. If separating the graph into Graph 1 and Graph 2, select the "Graph 2" check boxes for data to be displayed in Graph 2.

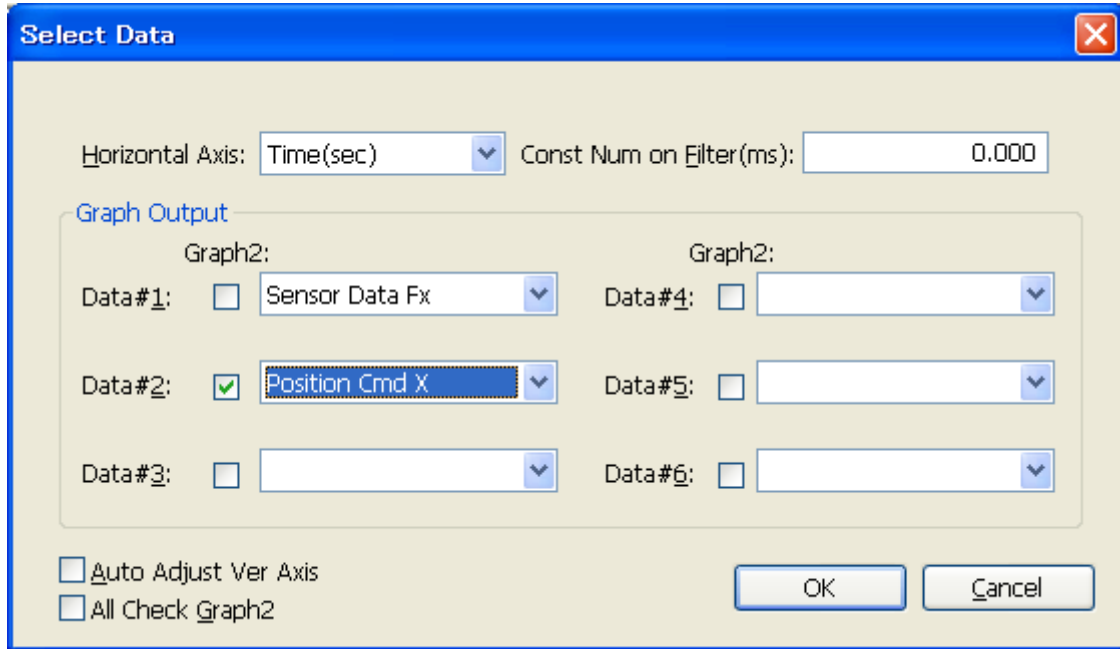

Fig. 8-4: Data Selection screen

Table 8-15: Data Selection screen description

No.	Item	Description
(1)	Graph horizontal axis	Select data to be used for the graph horizontal axis from a combo-box. [Selectable data] Time Position command: 1 from X, Y, Z, A, B, C, L1, or L2 Position FB: 1 from X, Y, Z, A, B, C, L1, or L2 Movement ratio: 1 from X, Y, Z, A, B, or C
(2)	Graph output	Select the data to be displayed in Graph 1 from a combo-box. (Max. 6 types) Select the respective "Graph 2" check boxes to display in Graph 2. [Selectable data] Force sensor data: Fx, Fy, Fz, Mx, My, Mz Position command: X, Y, Z, A, B, C, L1, L2 Position FB: X, Y, Z, A, B, C, L1, L2 Current FB: J1, J2, J3, J4, J5, J6, J7, J8 Raw sensor data: Fx, Fy, Fz, Mx, My, Mz (Values for which filter in (3) below does not apply.)
(3)	Filter time constant	Specify the filter time constant used for force sensor data filter processing. (Use to eliminate the influence of noise.) [Setting range] 0.00 to 2000.00 ms (When 0.00 is specified, filter processing is not performed.)
(4)	Automatically adjust vertical axis range.	When selected, the vertical axis display range is automatically adjusted.

### 8.3.4.4 Display Range Setting Screen

Sets the range for the displayed waveform data from the [Display Range] screen.

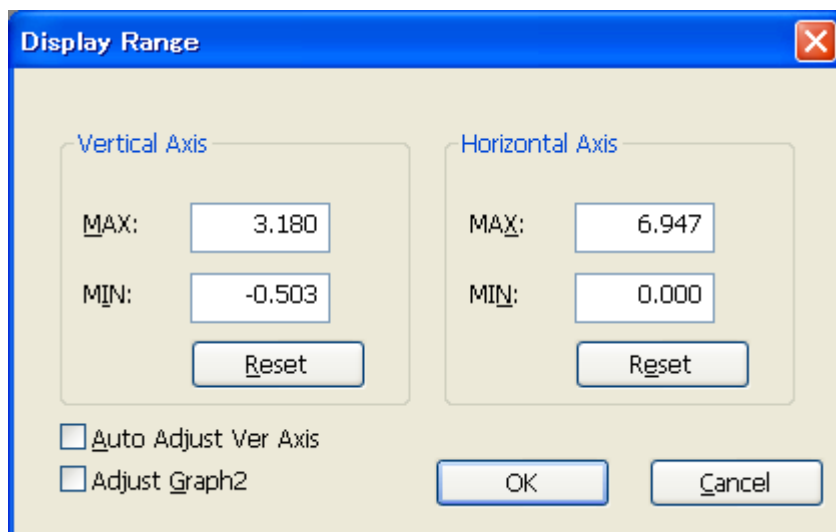

Fig. 8-5 Image of Display Range setting screen

Table 8-16 Display Range setting screen description

No.	Item	Description
(1)	Vertical axis display range setting	Specifies the maximum and minimum values for the Graph 1 horizontal axis. If adjusting the Graph 2 display range, select the "Adjust Graph 2" check box. By pressing the [Reset] button, the horizontal axis maximum and minimum values return to their default settings.
(2)	Horizontal axis display range setting	Specifies the maximum and minimum values for the Graph 1 vertical axis. If adjusting the Graph 2 display range, select the "Adjust Graph 2" check box. By pressing the [Reset] button, the vertical axis maximum and minimum values return to their default settings.
(3)	Automatically adjust vertical axis range.	When selected, the vertical axis display range is automatically adjusted.

### 8.3.5 Force Sense Log File FTP Transfer

Force sense log files created in the robot controller can be transferred to an FTP server using the robot language MELFA-BASIC V FsOutLog command.

<b><u>FsOutLog</u></b>	
[Function]	Transfers logged data to the FTP server.
[Syntax]	FsOutLog □ <Log File No.>
[Terminology]	<p>&lt;Log File No.&gt; Specifies the No. of the log file from which collected data is to be read. Setting range: 1 to 999999999</p>

The following preparations are required before the FsOutLog command can be executed.

(1) Network connection with Ethernet

Connect the robot controller and FTP server computer over the network with an Ethernet cable.

<CR750-Q Series connection example>

With the CR750-Q Series robot controller, FTP communication uses the robot CPU unit "DISPLAY I/F". Prepare a hub and Ethernet cable and connect to the network as shown below.

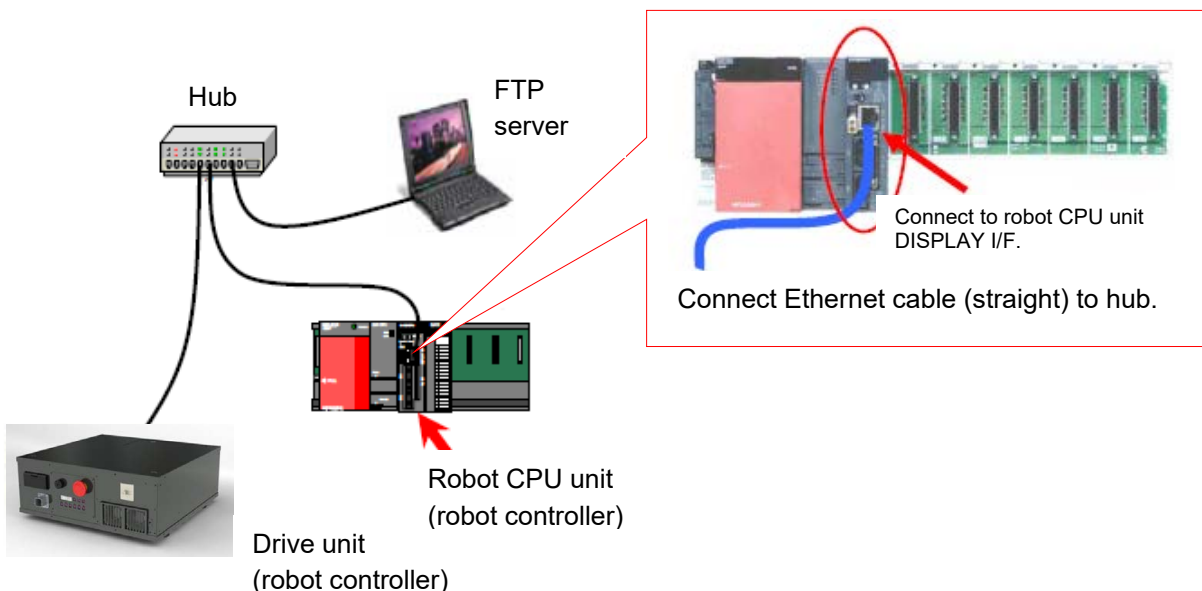

(2) FTP related parameter settings

Sets parameters FTPID, FTPPASS, FTPSVRIP, and FSLOGFN.

(Refer to section [8.3.2](#) for details on parameters.)

(3) FTP server preparation

Start up the FTP server on the target computer.

## 8.3.6 Usage Example (Force Sense Log)

### Force Sense Log Data Acquisition and Display

#### ■ Operation details

Acquires data for the force acting on the workpiece when performing assembly work and displays it in a graph.

- Pin insertion work is performed after starting force sense log data acquisition.
- After work is complete, force sense log data acquisition is terminated and log data acquired during work is saved.
- Acquired log data is displayed in a graph using the RT ToolBox2 force sense control log viewer function.

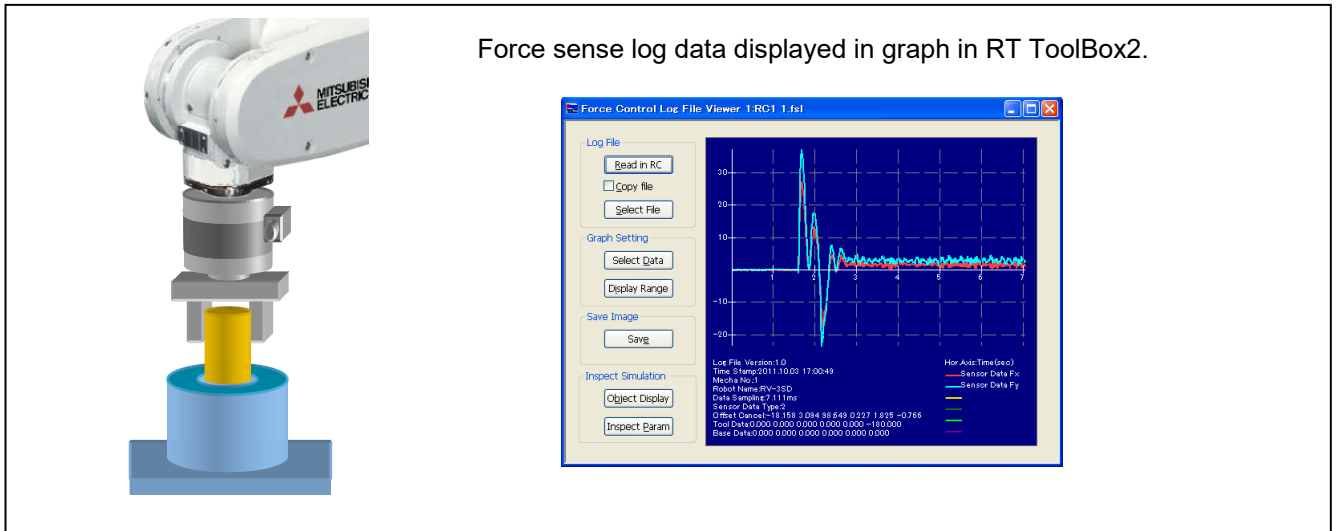

#### ■ Program example <Sample program F809.prg>

<code>[Control mode (0)]</code>	
<code>P_FsStf0 = (+0.00,+0.00,+0.00,+0.00,+0.00,+0.00)(0,0)</code>	'Stiffness coefficient [N/mm]
<code>P_FsDmp0 = (+0.00,+0.00,+0.00,+0.00,+0.00,+0.00)(0,0)</code>	'Damping coefficient
<code>P_FsMod0 = (+1.00,+1.00,+1.00,+0.00,+0.00,+0.00)(0,0)</code>	'Force control mode (X,Y,Z-axis force control)
<code>M_FsCod0 = 0</code>	'Force sense control coordinate system (tool)
<code>[Control characteristics (0)]</code>	
<code>P_FsGn0 = (+5.00,+5.00,+5.00,+0.00,+0.00,+0.00)(0,0)</code>	'Force control gain [ $\mu\text{m}/\text{N}$ ]
<code>P_FsFLm0 = (+0.00,+0.00,+0.00,+0.00,+0.00,+0.00)(0,0)</code>	'Force detection setting value [N]
<code>P_FsFCd0 = (+0.00,+0.00,+5.00,+0.00,+0.00,+0.00)(0,0)</code>	'Force command (X,Y-axes: 0.0 N, Z-axis: 5.0 N)
<code>P_FsSpd0 = (+0.00,+0.00,+0.00,+0.00,+0.00,+0.00)(0,0)</code>	'Sets speed control mode speed.
<code>P_FsSwF0 = (+0.00,+0.00,+0.00,+0.00,+0.00,+0.00)(0,0)</code>	'Sets force/speed judgment value.
<code>*** &lt;Log data acquisition&gt; ***</code>	
<code>Mov PStart</code>	
<code>Dly 1</code>	
<code>FsLog On</code>	'Force sense log data acquisition start
<code>Fsc On, 0, 0, 1</code>	'Force sense control enable (offset cancel designation)
<code>*LBL1: If P_FsCurD.Z &lt; 4.5 Then Goto *LBL1</code>	
<code>Fsc Off</code>	'Force sense control enable
<code>FsLog Off ,999</code>	'Log file creation (File name: 999.fsl)
<code>End</code>	'

■ Description

- 1) Specifies settings to push the robot with a force of 0.0 N in the X- and Y-directions, and 5.0 N in the Z-direction with force control.
- 2) The FsLog On command is executed to start log data acquisition.
- 3) Insertion work is started with the Fsc On command, and the robot pushes until a reaction force of 4.5 N or greater acts in the Z-direction.
- 4) The FsLog Off command is executed to end log data acquisition. (The log data file name is set for the argument.)
- 5) Measurement data is displayed in a graph using the RT-ToolBox2 "force sense control log file viewer" to check the force acting on the workpiece. (See section [8.3.4](#) for details on how to use the force sense control log file viewer.)





## 8.4 Gravity Offset Cancel Function

Gravity offset cancel is a function that the offset cancel in response to a change in the direction of gravity applied to the force sensor by hand load at the time of posture change. To use this function, it is necessary to estimate the bias value of the force sensor, position of the center of gravity and the mass of hand load by the force calibration.

### 8.4.1 Estimated data

The data estimated by the force sensor calibration function is explained below.

- (1) Force sensor bias value
- (2) Load center of gravity position  
The center of gravity position of the load attached the force sensor.
- (3) Load mass  
The mass of the load attached the force sensor.

### 8.4.2 About Calibration Posture

The force calibration is required nine posture shown in Table 8-17. It shows the movement image of the posture No. 1 to 5 in Fig. 8-6.

**Table 8-17: Posture for force calibration**

Posture No.	Condition
1	Posture that the mechanical interface is parallel to the ground.
2	Posture rotated in the +X-axis around the mechanical interface with respect to posture No.1.
3	Posture rotated in the -X-axis around the mechanical interface with respect to posture No.1.
4	Posture rotated in the +Y-axis around the mechanical interface with respect to posture No.1.
5	Posture rotated in the -Y-axis around the mechanical interface with respect to posture No.1.
6	Posture rotated in the +X-axis around the mechanical interface with respect to posture No.1. * Rotate at different angle from posture No.2.
7	Posture rotated in the -X-axis around the mechanical interface with respect to posture No.1. * Rotate at different angle from posture No.3.
8	Posture rotated in the +Y-axis around the mechanical interface with respect to posture No.1. * Rotate at different angle from posture No.4.
9	Posture rotated in the -Y-axis around the mechanical interface with respect to posture No.1. * Rotate at different angle from posture No.5.

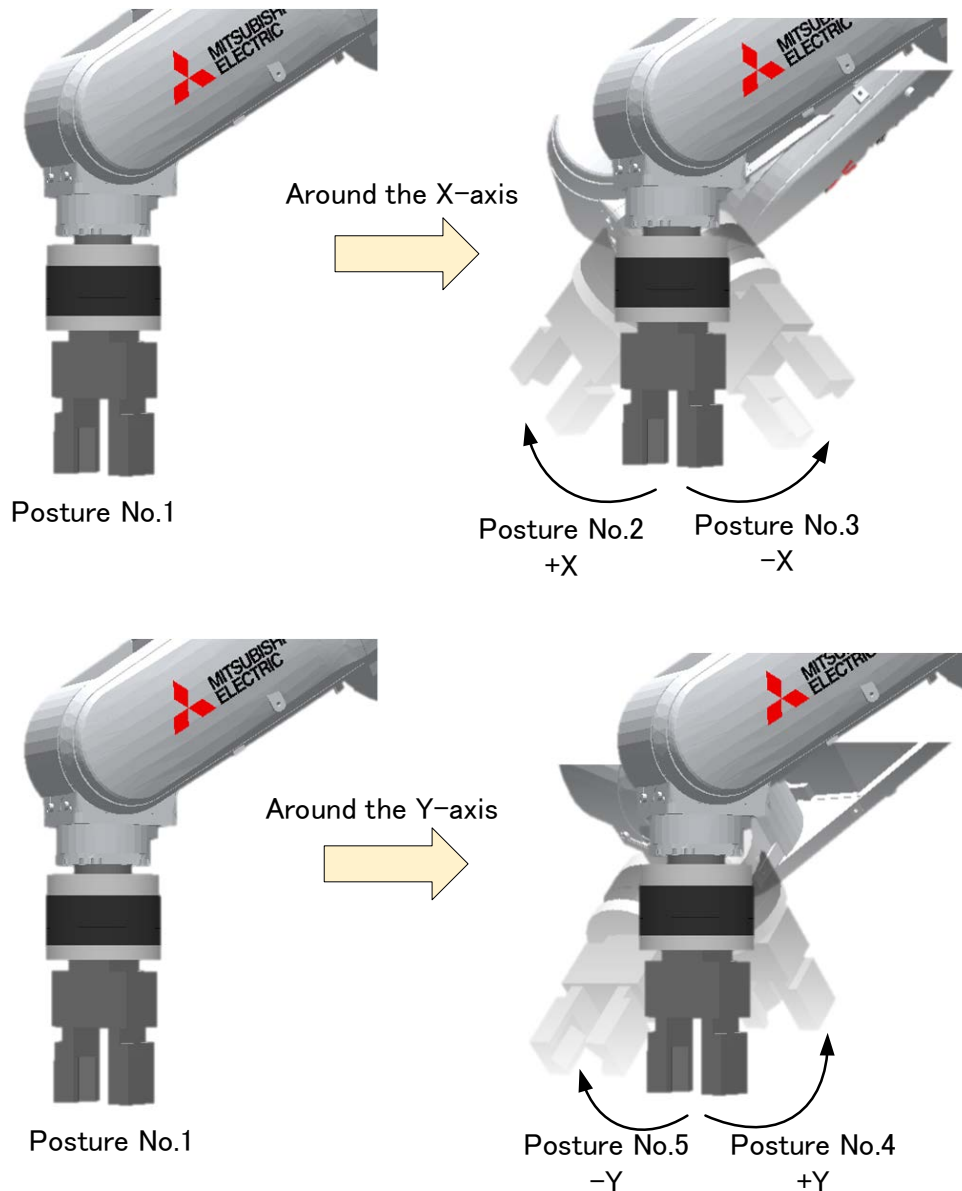

Fig. 8-6: Movement image of force calibration

## Caution

Set the angle smaller than reference value if the robot interfere with the peripheral device or the tension of air hose attached to hand of various cable changes by the robot's posture change and load is applied to force sensor other than gravity.

### 8.4.3 Calibration Procedure

Estimation by the force calibration has the following two ways.

- 1) Estimated using the force calibration screen. (See section [8.4.3.1](#))
- 2) Estimated using the robot program. (See section [8.4.3.2](#))

### 8.4.3.1 Estimated Using the Force Calibration Screen

The force calibration screen can be used with RT ToolBox2 Version 3.60N or later.

- 1) Specify the program name for the calibration  
 Select [Tool] -> [Force sensor calibration] from the project tree, Please Start force calibration screen. Please input the program name for the force calibration in the force calibration start screen.  
 (Input program is generated automatically, and execute force calibration. After calibration is complete, the program will be removed from the controller.)

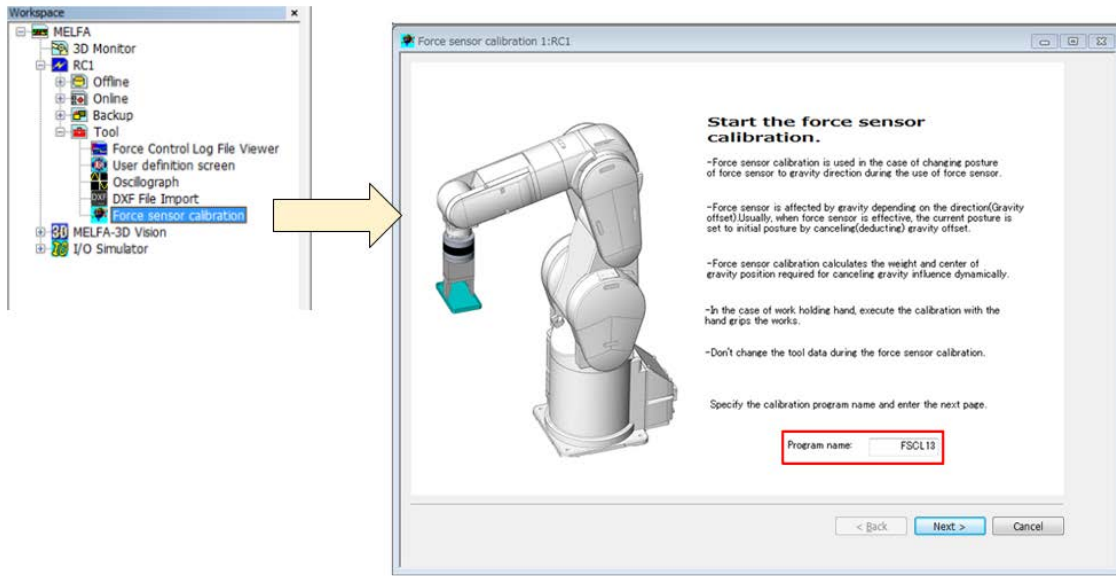

- 2) Specify the control mode number that becomes a storage destination of the calibration results.  
 Please Specify the control mode number (1-9) to store the results, which is estimated by the calibration execute. In this screen, select the control mode number to store the results from the drop-down list. At the time of gravity offset cancel, data storage destination specified by the control mode number is used.

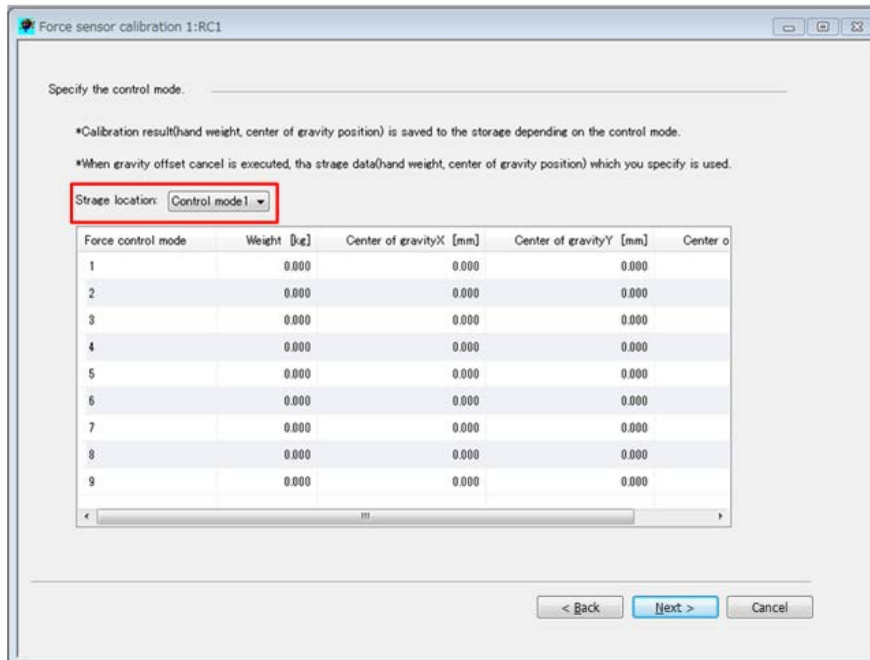

## 3) Register the start position

Please register the start position for force calibration. Set the position at which the mechanical interface of robot is parallel to the ground to the start position. In force calibration, rotate the X-axis and Y-axis around the mechanical interface. Please adjust the start position to the position that does not interfere with the peripheral device.

After moved the robot to near the start position, Please click [Auto adjustment] button. The robot moves to position the mechanical interface is parallel to the ground. After moved the robot to the start position, Please click [Get the current position] button. The current position of the robot is registered.

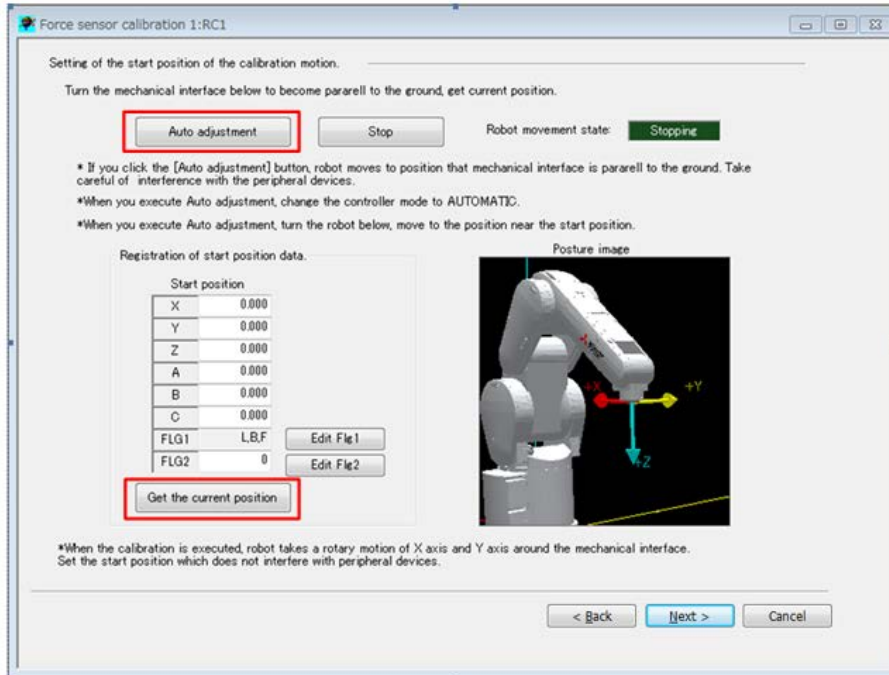
**Caution**

If [Auto adjustment] button is clicked, robot moves. Please check the safety of around the robot. If the override is greater than 10 %, override is changed to 10% for safety. Please prepare T/B to stop anytime in the emergency.

## 4) Specify the rotary angle for calibration movement

Please specify the rotary angle from the start position. In force calibration, the robot is rotated by a specified angle twice in the X-axis and Y-axis around the mechanical interface to the start position.

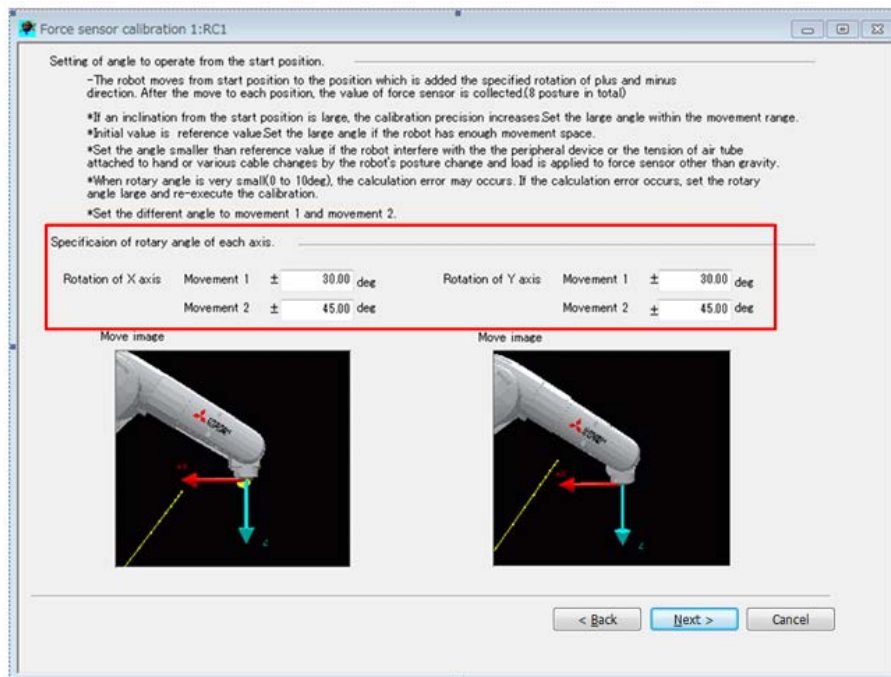

**!** **Caution**

Set the angle smaller than reference value if the robot interfere with the peripheral device or the tension of air hose attached to hand of various cable changes by the robot's posture change and load is applied to force sensor other than gravity.

**!** **Caution**

If the rotary angle is below 10[deg], calibration calculation error can occur. In that case, set the rotary angle large and re-execute the calibration.

**!** **Caution**

If the angles of movement 1 and movement 2 are same value, calibration results are not calculated correctly. Set the different angle to movement 1 and movement 2.

## 5) Confirm the posture for calibration

Confirm the robot movement to 9 calibration movement data automatically made from the start position and rotary angle data to use [Position jump] button. After select the movement position in the movement position data list, please click [Position jump] button and confirm the robot movement.

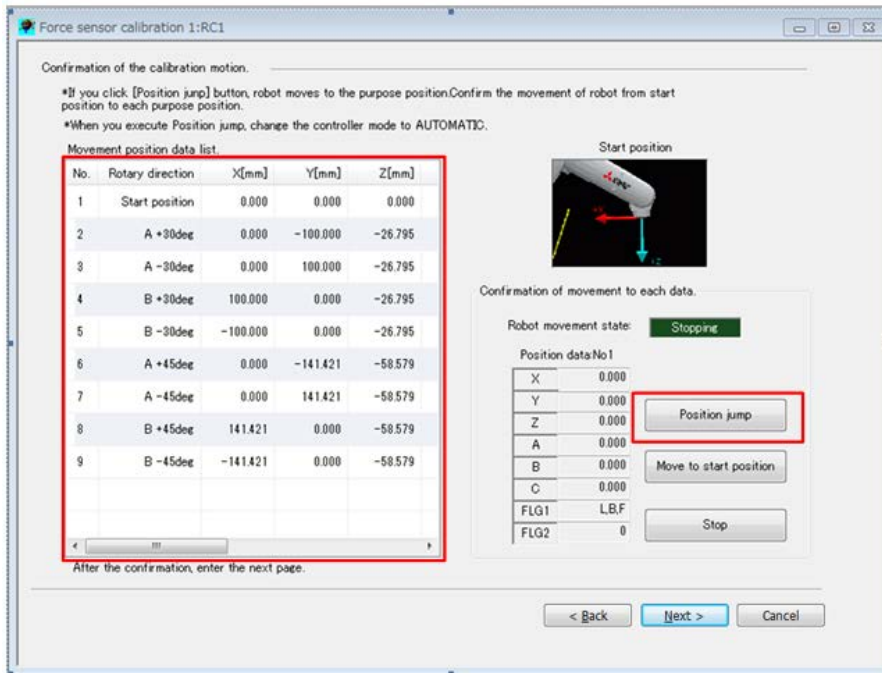
**Caution**

If [Position jump] button is clicked, robot moves. Please check the safety of around the robot. If the override is greater than 10 %, override is changed to 10% for safety. Please prepare T/B to stop anytime in the emergency.

6) Execute the calibration movement

Please execute the robot program for force calibration. If [Start operation panel] button is clicked, operation panel is started that the force calibration program is selected. Please click [Start] button from operation panel and start the calibration. If the calibration is completed, calibration result (hand's weight and center of gravity position) is displayed after the showing of complete message. Please click [Finish] button and end the calibration.

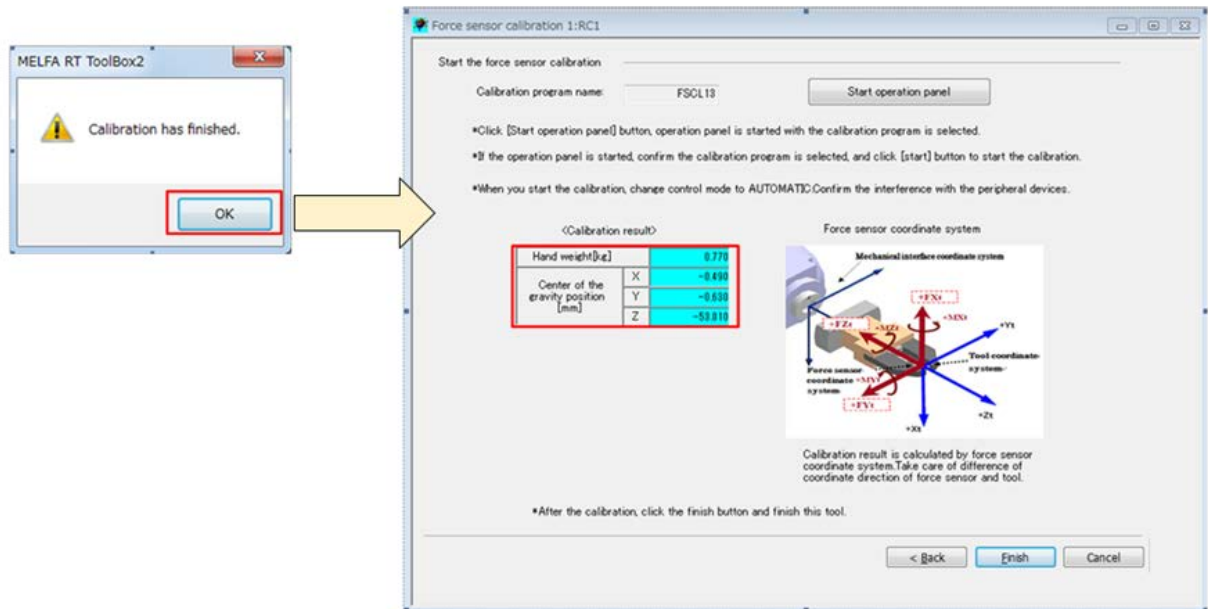
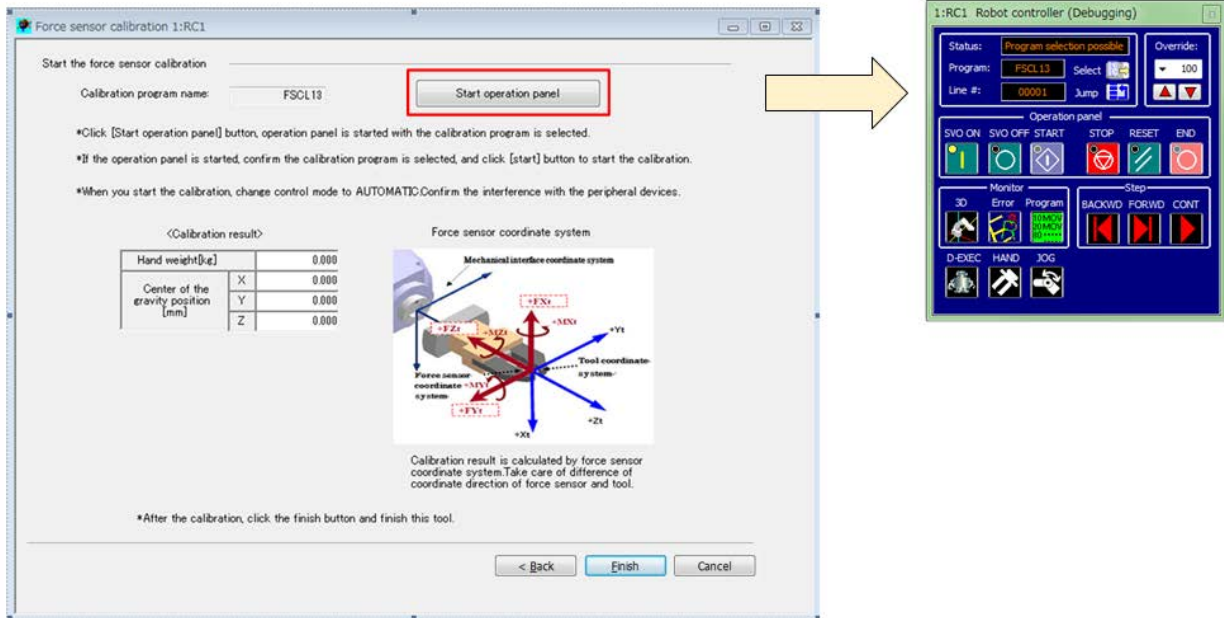

**Caution**

If [Start] button is clicked, robot moves. Please check the safety of around the robot. If the override is greater than 10 %, override is changed to 10% for safety. Please prepare T/B to stop anytime in the emergency.

**Caution**

If the movement speed of robot increases, calibration precision decreases. Do not change default override value as much as possible.



**Caution**

When you click [Finish] button to exit the force calibration, the program used in the calibration will be removed from the controller.

**8.4.3.2 Estimated Using the Robot Program**

Using the robot program estimate the mass and the position of the center of gravity of the hand load. If you want to estimate a robot program, use the following commands. Please refer to Chapter 11.6 for details commands.

**Table 8-18: Gravity offset cancel commands**

No.	Command	Function Overview
1	FsHndEst On	To begin the processing of the force calibration.
2	FsHndEst Off	To estimate the force calibration result, to complete the process.
3	FsGetDat	To get the data (current position and the force sensor data) required to the force calibration.

The force calibration by executing the following robot program, estimate the hand load.

**■ Program example**

```

**** < Force sense calibration execution > ****
Dim PP(9)
Servo On
Mov PP(1)           'Robot moves to the start point.
Dly 1
FsHndEst On,0      'Execute the calibration
For M1=1 To 9 Step 1
  Mov PP(M1)       'Robot moves to the calibration posture
  Dly 1.5          ' Wait until the robot stops
  FsGetDat M1      'The current position and force sense data acquisition
  Mov PP(1)       'Robot moves to the start point.
  Dly 0.5
Next M1
FsHndEst Off      'Calibration is completed. Estiamte the load.
End

```

## 8.4.4 Usage Example (Force Sensor Calibration)

### Force sensor calibration

#### ■ Operation details

Estimates the mass and the center of gravity position of the hand by the force sensor calibration function.

- Execute the force sensor calibration.
- Enable the force sensor control that is enabled the gravity offset cancel.

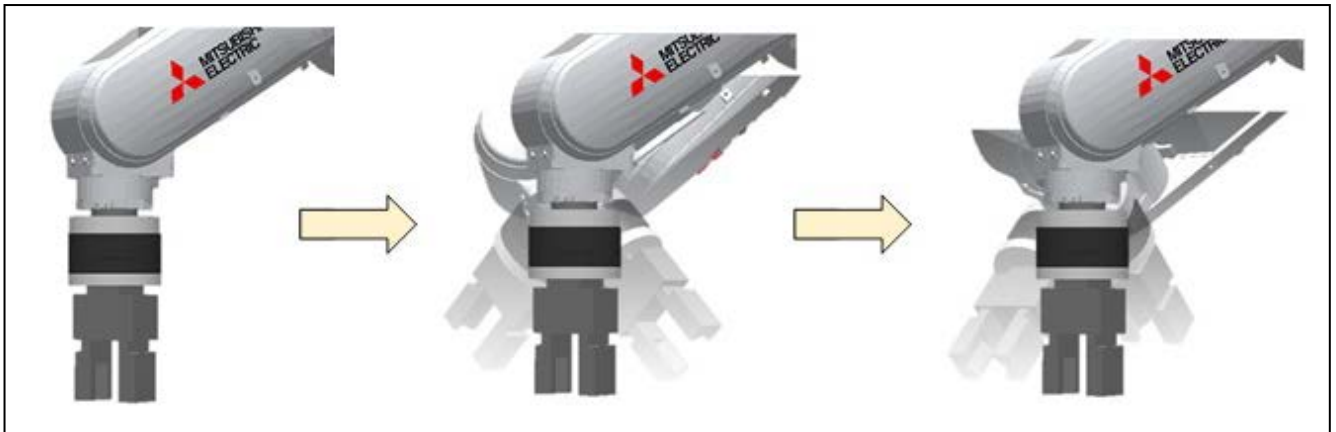

#### ■ Program example < Sample Program F811.prg >

```

'[Control mode (0)]
P_FsStf0 = (+0.00,+0.00,+0.00,+0.00,+0.00,+0.00)(0,0)      'Stiffness coefficient [N/mm]
P_FsDmp0 = (+0.00,+0.00,+0.00,+0.00,+0.00,+0.00)(0,0)    'Damping coefficient
P_FsMod0 = (+0.00,+0.00,+1.00,+0.00,+0.00,+0.00)(0,0)     'Force control mode (Z-axis force control)
M_FsCod0 = 0                                               'Force sense control coordinate system (tool)
'[Control characteristics (0)]
P_FsGn0 = (+0.00,+0.00,+10.00,+0.00,+0.00,+0.00)(0,0)    'Force control gain [μm/N]
P_FsFLm0 = (+0.00,+0.00,+0.00,+0.00,+0.00,+0.00)(0,0)    'Force detection setting value [N]
P_FsFCd0 = (+0.00,+0.00,+10.00,+0.00,+0.00,+0.00)(0,0)  'Force command (FZt direction, 10N)
P_FsSpd0 = (+0.00,+0.00,+0.00,+0.00,+0.00,+0.00)(0,0)   'Sets speed control mode speed.
P_FsSwF0 = (+0.00,+0.00,+0.00,+0.00,+0.00,+0.00)(0,0)   'Sets force/speed judgment value.
'*** < Force sense calibration execution > ***
Dim PP(9)
Servo On
Mov PP(1)                                                  'Robot moves to the start point.
Dly 1
FsHndEst On,0                                           'Execute the calibration
For M1=1 To 9 Step 1
  Mov PP(M1)                                             'Robot moves to the calibration posture
  Dly 1.5
  FsGetDat M1                                           'The current position and force sense data acquisition
  Mov PP(1)                                             'Robot moves to the start point.
  Dly 0.5
Next M1
FsHndEst Off                                             'Calibration is completed. Estimate the load.
Fsc On,0,0,1                                             'Force sens control is enabled
Dly 10
Fsc Off                                                  'Force sens control is disabled
End

```

■ Description

- 1) The "control mode" and "control characteristics " used after the calibration are set at the beginning of the program.
- 2) The force sense calibration is started with the FsHndEst On command.
- 3) After the robot moves to each calibration posture, the current position, the posture, and the force sensor data are obtained with the FsGetDat command.
- 4) The force sense calibration is completed with the FsHndEst Off command and the mass and the center of gravity position of the hand are estimated.
- 5) The force sense control in which the gravity offset is cancelled using the data estimated with the Fsc On command is enabled.

\* Details for the FsHndEst command and FsGetDat command, see section [11.6](#).

## 9 Using the Force Sense Function (Teaching)

This Chapter describes how to use the force sense function (force sense T/B) using the teaching pendant, and how to perform teaching using the force sense function.

Refer to the section numbers and pages under "Reference" in the following table for a "description" and "usage example" for each function.

**Table 9-1: Force sense function usage method reference list (teaching)**

Function Class		Function Overview	Reference	
			Description	Usage Example
Force sense T/B	Force sense control (T/B)	Controls push force and softness.	<a href="#">Section 9.1.1</a>	<a href="#">Page 9-111</a>
	Force sense monitor	Checks force sense data.	<a href="#">Section 9.1.2</a>	<a href="#">Page 9-113</a>
	Contact detection	Checks the contact position.	<a href="#">Section 9.1.3</a>	
Teaching		Teaches the push position.	<a href="#">Section 9.2</a>	<a href="#">Page 9-119</a>
		Teaches the insertion position (using force control).		<a href="#">Page 9-121</a>
		Teaches the insertion position (using stiffness control).		<a href="#">Page 9-123</a>

## 9.1 Force Sense T/B

The force sense functions that can be used from R56TB/R57TB/R32TB/R33TB are summarized in "Table 9-2".

**Table 9-2: Force sense functions that can be used from teaching pendant**

Force Item		Function Overview
Force sense control (T/B)	Force control	Pushes with the specified force using force control.
	Stiffness control	Controls the robot softly like a spring.
Force sense monitor	Force sense data display	Displays the force sensor data current value on the T/B.
	Max. value retention	Retains the force sensor data maximum value. (Resetting is possible.)
Force sense monitor	Automatic stop	Stops the robot automatically when contact is detected during JOG operation.
	Buzzer sound	Sounds the buzzer when the contact detection threshold is exceeded.

Each function is described below.

### 9.1.1 Force Sense Control (T/B)

JOG operation using force sense control can be performed from the teaching pendant. Force sense control facilitates more precise teaching operations such as controlling the robot softly to the assembly position while escaping external force, and teaching positions pushed with a fixed force. (See section [8.1](#) for details on force sense control.)

If performing JOG operation while using force sense control, use the following procedure to sufficiently check the setting status before turning the servo ON.

[Turning the servo ON when force sense control is enabled]

**Step 1: Offset cancel operation** (See section [9.1.1.1](#).)

...Ensure that the force sensor offset component has been cancelled.



**Step 2: Control mode/control characteristics selection** (See section [9.1.1.2](#).)

...Ensure that the used control mode/ control characteristics have been set correctly.



**Step 3: Force sense control enabled/disabled selection** (See section [9.1.1.3](#).)

...Check the force sense control enabled/disabled status.



Servo ON

### 9.1.1.1 Offset Cancel Operation

If the force sensor data zero point is offset, force sense control will not function properly. Always perform the **offset cancel operation (sensor zero point offset)** before use. The offset cancel operation can only be performed when force sense control is disabled.

[Offset cancel operation]

- Move the robot to a position at which no external force acts on the sensor (position at which no contact is made with hand, etc.)
- Ensure that the robot is stationary and then perform the offset cancel operation. (See diagram below).

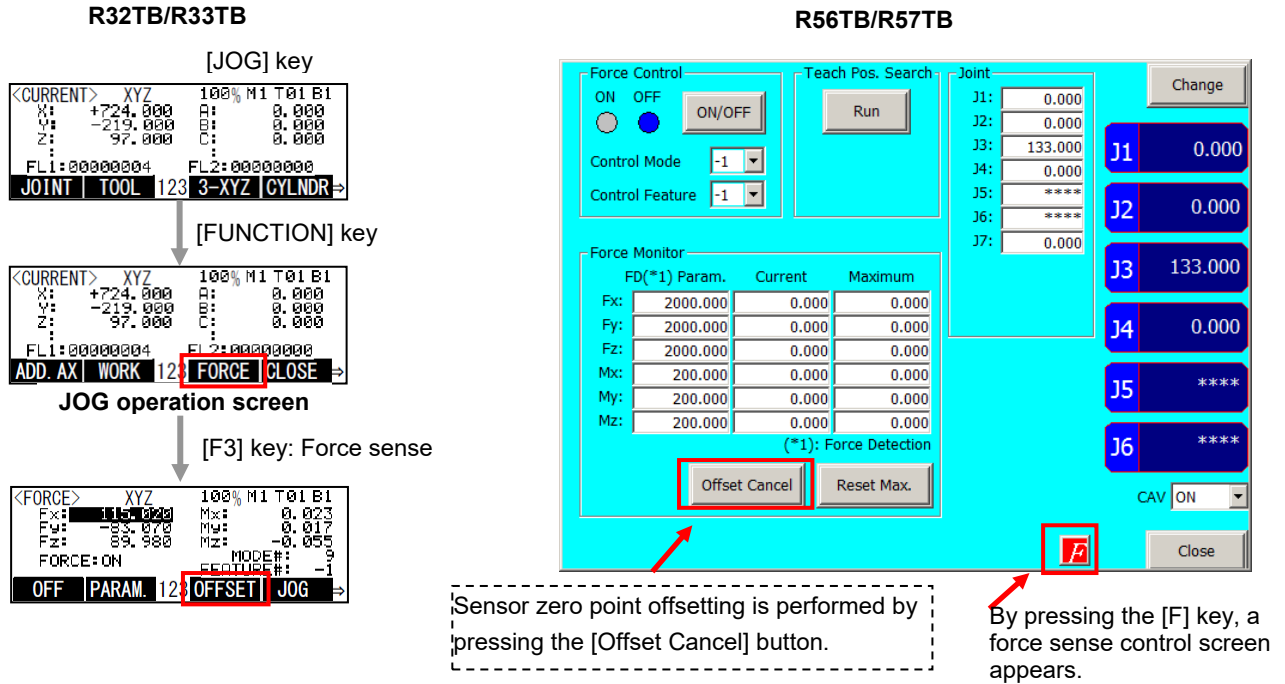

#### Offset cancel operation precautions

- The offset cancel status is reset by rebooting the controller. If the controller is rebooted, perform the offset cancel operation again.
- The effects of gravity are contained in the sensor offset component, and therefore if the robot arm posture is changed significantly, it is necessary to perform the offset cancel operation again.
- The offset amount may change if used for long periods of time due to changes in sensor temperature (temperature drift). In such a case, perform the offset cancel operation again.

### 9.1.1.2 Selecting the Control Mode/Control characteristics

Before enabling force sense control, it is necessary to set the force sense control "control mode" and "control characteristics" (parameters/status variables shown in Table 9-3) beforehand. (See section 8.1.2 for details.)

**Table 9-3: Control mode/Control characteristics settings**

Setting Item		Status Variable (*=0, 1)	Parameter (#=1 - 9)	Default Factory Setting
Control mode	Force sense control coordinate system	M_FsCod*	FSCOD0#	0
	Force control mode	P_FsMod*	FSFMD0#	0.00, 0.00, 0.00, 0.00, 0.00, 0.00
	Stiffness coefficient	P_FsStf*	FSSTF0#	0.00, 0.00, 0.00, 0.00, 0.00, 0.00
	Damping coefficient	P_FsDmp*	FSDMP0#	0.00, 0.00, 0.00, 0.00, 0.00, 0.00
Control characteristics	Force command value (force control) Limit value (Limited stiffness control)	P_FsFCd*	FSFCMD0#	0.00, 0.00, 0.00, 0.00, 0.00, 0.00
	Speed command value	P_FsSpd*	FSSPD0#	0.00, 0.00, 0.00, 0.00, 0.00, 0.00
	Mode switching judgment value	P_FsSwF*	FSSWF0#	0.00, 0.00, 0.00, 0.00, 0.00, 0.00
	Force sense control gain	P_FsGn*	FSFGN0#	0.00, 0.00, 0.00, 0.00, 0.00, 0.00
	Force detection setting value	P_FsFLm*	FSFLMT0#	0.00, 0.00, 0.00, 0.00, 0.00, 0.00

[Control mode/ Control characteristics selection operation]

- Specify the used "control mode" and "control characteristics" number.
- Ensure that the numbers used have been set correctly before enabling force sense control.

**R32TB/R33TB**

**JOG operation screen**

[F3] key: Force sense

**Condition settings screen**

**R56TB/R57TB**

Force Control ON/OFF

Control Mode: -1

Control Feature: -1

Force Monitor

FD(\*1) Param. Current Maximum

Offset Cancel Reset Max.

By pressing the [F] key, a force sense control screen appears.

Specify the "control mode" and "control features" number.

### 9.1.1.3 Force Sense Control Enable/Disable Selection

Enable or disable force sense control. If performing JOG operation using force sense control, select "Enable", and if performing normal JOG operation, select "Disable".

The enable/disable selection is common to both automatic operation and JOG operation. The enable/disable status is retained even if the controller key switch is changed to and from MANUAL and AUTOMATIC.

<Example 1>

Force sense control enabled in automatic operation → operation interrupted → Operation key switch changed to MANUAL → T/B enabled → force sense control enabled status retained.

< Example 2>

Force sense control enabled with T/B → T/B disabled → Operation key switch changed to AUTOMATIC → force sense control enabled status retained.

However, if the enabled/disabled status differs when interrupting and resuming robot program automatic operation, error L3986 occurs when resuming operation.



## Caution

The force sense control enable/disable status is retained even when automatic operation is stopped and the operation mode changed to MANUAL mode. Perform teaching after checking the force sense control enable/disable status, and control mode/control characteristics settings sufficiently.

[Force sense control enable/disable operation]

- Enable/disable force sense control with the ON/OFF button. (See below.)
- The enabled/disabled status is displayed on the T/B screen. (See below.)

**R32TB/R33TB**

```

<CURRENT> XYZ 100% M1 T01 B1
X: +724.000 A: 0.000
Y: -219.000 B: 0.000
Z: -97.000 C: 0.000
FL1:00000004 FL2:00000000
JOINT TOOL 123 3-XYZ |CYLDR|
        
```

↓ [FUNCTION] key

```

<CURRENT> XYZ 100% M1 T01 B1
X: +724.000 A: 0.000
Y: -219.000 B: 0.000
Z: -97.000 C: 0.000
FL1:00000004 FL2:00000000
ADD. AX WORK 123 FORCE |CLOSE|
        
```

↓ [F3] key:

Force sense

```

<FORCE> XYZ 100% M1 T01 B1
Fx: 115.020 Mx: 0.023
Fy: -83.070 My: 0.017
Fz: 89.920 Mz: -0.055
MUDE#: 1
FEATURE#: -1
ON PARAM. 123 OFFSET JOG
FORCE: ON
OFF PARAM. 123 OFFSET JOG
        
```

↓ [F1] key: Enables/disables force sense control with ON/OFF button.

**R56TB/R57TB**

Force Control: ON OFF ON/OFF

Control Mode: -1

Control Feature: -1

FD(*1)	Param.	Current	Maximum
Fx:	2000.000	0.000	0.000
Fy:	2000.000	0.000	0.000
Fz:	2000.000	0.000	0.000
Mx:	200.000	0.000	0.000
My:	200.000	0.000	0.000
Mz:	200.000	0.000	0.000

(\*1): Force Detection

Offset Cancel Reset Max.

By pressing the [F] key, a force sense control screen appears.



### 9.1.2 Force Sense Monitor

Displays the force sensor current and maximum values. Retained maximum values can also be cleared.

[Checking the force sensor data current/maximum values]

- The force sensor data current and maximum values are shown below.
- The coordinate system for the displayed sensor data is based on the force sensor coordinate system set for the "control mode".

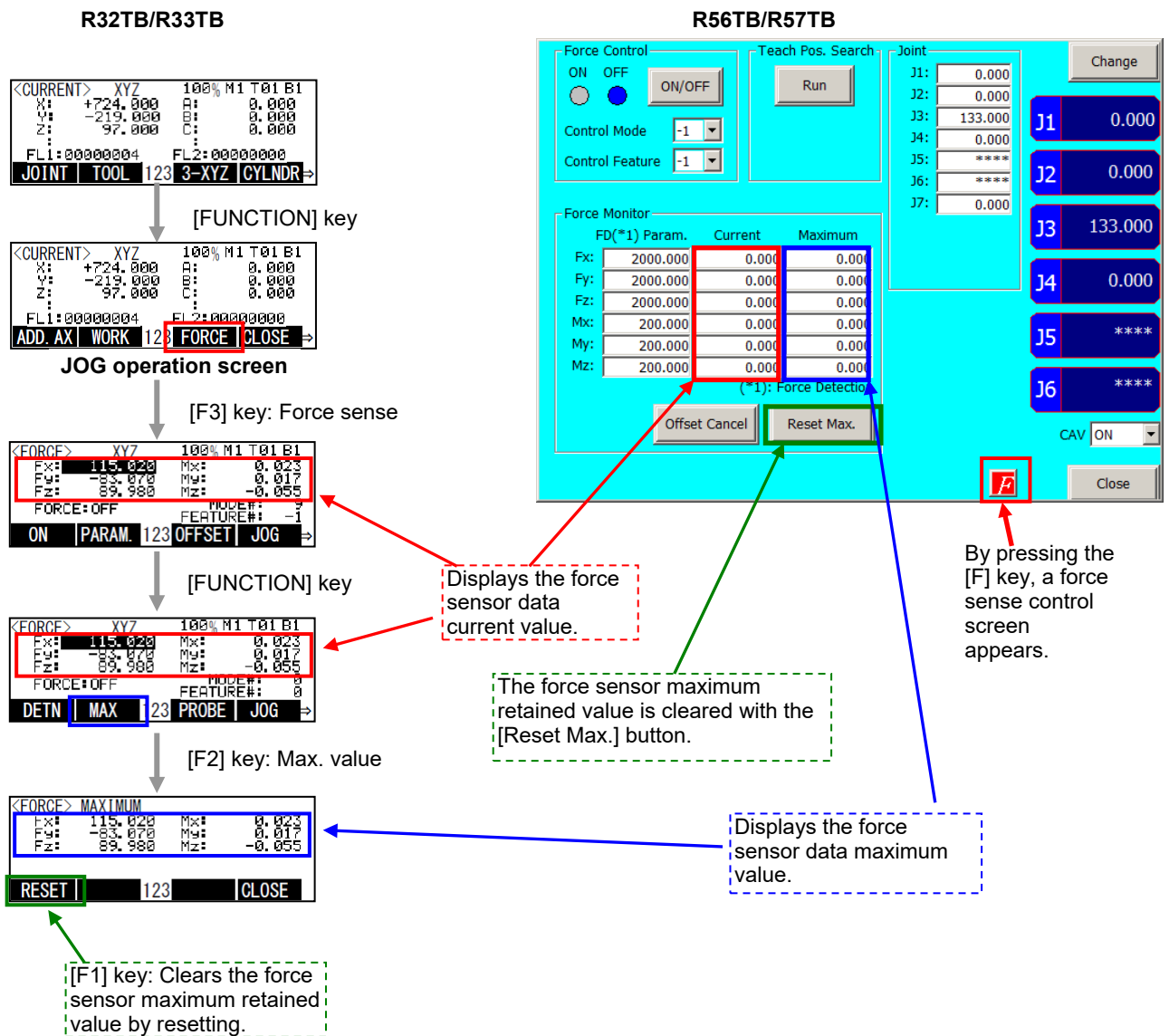

### 9.1.3 Contact Detection

If the force sense data exceeds the selected "control characteristics" force detection setting value while force sense control is enabled, JOG operation is automatically stopped. Furthermore, the buzzer sounds and the force sensor data display field on the teaching pendant changes color to notify the user that the force detection setting value has been exceeded.

[Contact detection operation]

- Set the threshold value used to detect the contact status for the "control characteristics" force detection setting value. (See section 9.1.1.2.)
- Enable force sense control. (See section 9.1.1.)
- If the force sensor data exceeds the force detection setting value during JOG operation, operation is stopped and the buzzer sounds.
- The currently selected force detection setting value appears on the teaching pendant. (See below.)

**R32TB/R33TB**

```

<CURRENT> XYZ 100% M1 T01 B1
X: +724.000 A: 0.000
Y: -219.000 B: 0.000
Z: 97.000 C: 0.000
FL1:00000004 FL2:00000000
JOINT TOOL 123 3-XYZ |CYLNDR =>
                
```

[FUNCTION] key

```

<CURRENT> XYZ 100% M1 T01 B1
X: +724.000 A: 0.000
Y: -219.000 B: 0.000
Z: 97.000 C: 0.000
FL1:00000004 FL2:00000000
ADD. AX |WORK 123 |FORCE |CLOSE =>
                
```

**JOG operation screen**

[F3] key: Force sense

```

<FORCE> XYZ 100% M1 T01 B1
Fx: 115.023 Mx: 0.023
Fy: 83.070 My: 0.017
Fz: 89.980 Mz: -0.055
FORCE=OFF MODE#: 9
ON |PARAM. 123 |OFFSET |JOG =>
                
```

[FUNCTION] key

```

<FORCE> XYZ 100% M1 T01 B1
Fx: 115.023 Mx: 0.023
Fy: 83.070 My: 0.017
Fz: 89.980 Mz: -0.055
FORCE=OFF MODE#: 9
DET |MAX 123 |PROBE |JOG =>
                
```

[F2] key: Max. value

```

<FORCE> DETECTION SETTINGS
Fx: 0.000 Mx: 0.000
Fy: 0.000 My: 0.000
Fz: 0.000 Mz: 0.000
123 |CLOSE
                
```

**R56TB/R57TB**

Force Control: ON OFF ON/OFF

Teach Pos. Search: Run

Force Monitor:

FD(*1) Param	Current	Maximum
Fx:	2000.000	0.000
Fy:	2000.000	0.000
Fz:	2000.000	0.000
Mx:	200.000	0.000
My:	200.000	0.000
Mz:	200.000	0.000

(\*1): Force Detection

Offset Cancel Reset Max.

By pressing the [F] key, a force sense control screen appears.

■□■ Contact detection precautions ■□■

- When the robot is stopped by contact detection, the robot moves from the point the force is detected until the robot stops, and therefore a larger force than the force detection setting value may act.
- If JOG operation is stopped when the force detection setting value is exceeded, check the force sensor data value and then move the robot in the direction that the acting force becomes smaller.
- If the force detection setting value is greatly exceeded while force sense control is enabled, it will not longer be able to perform JOG operation. (Slight movement is possible.) In such a case, disable force sense control, and then move the robot by JOG operation. When doing so, take caution not to move in a direction in which a large force acts.

## 9.1.4 Usage Example (Force Sense Function T/B)

### Force Sense Control T/B (Force Control)

#### ■ Operation details

The robot is pushed with a force of 20 N in the Z-direction (tool coordinates) with the teaching pendant.



#### ■ Operation procedure

##### (1) Parameter settings

- Set the "control mode" and "control characteristics" so that the robot is pushed with a force of 20 N in the tool Z-direction. (See table below.)
- Settings are easy using the dedicated screen at the RT ToolBox2 (or R56TB/R57TB). Furthermore, parameters relating to the control mode/control characteristics are updated immediately, and therefore there is no need to reboot the controller. (See section [12.2](#).)

Control mode	Force sense control coordinate system	FSCOD01	0
	Force control mode	FSFMD01	<b>+0.00, +0.00, +1.00, +0.00, +0.00, +0.00</b>
	Stiffness coefficient	FSSTF01	+0.00, +0.00, +0.00, +0.00, +0.00, +0.00
	Damping coefficient	FSDMP01	+0.00, +0.00, +0.00, +0.00, +0.00, +0.00
Control characteristics	Force command value	FSFCMD01	<b>+0.00, +0.00, +20.00, +0.00, +0.00, +0.00</b>
	Speed command value	FSSPD01	+0.00, +0.00, +0.00, +0.00, +0.00, +0.00
	Mode switching judgment value	FSSWF01	+0.00, +0.00, +0.00, +0.00, +0.00, +0.00
	Force sense control gain	FSFGN01	<b>+0.00, +0.00, +5.00, +0.00, +0.00, +0.00</b>
	Force detection setting value	FSFLMT01	+0.00, +0.00, +0.00, +0.00, +0.00, +0.00

(\* In this example, settings are specified with parameters, however, setting is also possible with status variables.)

##### (2) Offset cancel operation (See section [9.1.1.1](#).)

- Perform force sensor zero point offset.
  - \* Perform offset cancel with no external forces acting other than gravity.

(3) Control mode/control characteristics selection (See section [9.1.1.2.](#))

- Set the "control mode" and "control characteristics" numbers. In this example, control mode 1 and control characteristics 1 are used, and therefore the settings are as follows.

[R32TB/R33TB]

<FORCE> PARAMETER	
CONTROL MODE	( 1 )
CONTROL FEATURE	( 1 )
	123
	CLOSE

(4) Force sense control enable operation (See section [9.1.1.3.](#))

- Turn the servo ON after enabling force sense control.
- Force sense control is enabled and the robot moves automatically to the position at which a reaction force of 20 N can be obtained. Movement is also possible with normal JOG operation while force sense control is enabled.

## Contact Detection/Force Sense Monitor

### ■ Operation details

JOG operation is stopped automatically if unnecessary force acts on the workpiece. Check the maximum value for force applied to the workpiece.

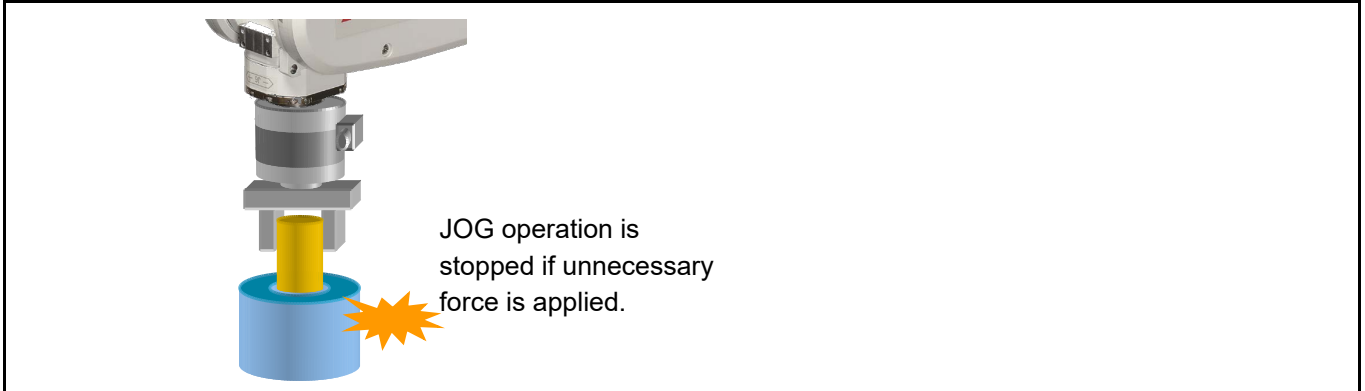

### ■ Operation procedure

#### (1) Parameter settings

- When inserting, stiffness control (stiffness coefficient = 0) is specified only in the X- and Y-directions to ensure that the robot can move freely in response to the reaction force.
- Set the "force detection setting value" so that the robot stops following contact detection when a force of 5 N or more acts in the FXt, Fyt, or FZt directions, and a moment of 0.05 N·m or more acts in the MXt, MYt, or MZt directions. (See table below.)

Control mode	Force sense control coordinate system	FSCOD01	0
	Force control mode	FSFMD01	<b>+2.00, +2.00, +0.00, +0.00, +0.00, +0.00</b>
	Stiffness coefficient	FSSTF01	<b>+0.00, +0.00, +0.00, +0.00, +0.00, +0.00</b>
	Damping coefficient	FSDMP01	+0.00, +0.00, +0.00, +0.00, +0.00, +0.00
Control characteristics	Force command value	FSFCMD01	+0.00, +0.00, +0.00, +0.00, +0.00, +0.00
	Speed command value	FSSPD01	+0.00, +0.00, +0.00, +0.00, +0.00, +0.00
	Mode switching judgment value	FSSWF01	+0.00, +0.00, +0.00, +0.00, +0.00, +0.00
	Force sense control gain	FSFGN01	<b>+1.50, +1.50, +0.00, +0.00, +0.00, +0.00</b>
	Force detection setting value	FSFLMT01	<b>+5.00, +5.00, +5.00, +0.05, +0.05, +0.05</b>

(\* In this example, settings are specified with parameters, however, setting is also possible with status variables.)

#### (2) Offset cancel operation (See section [9.1.1.1.](#))

- Perform force sensor zero point offset.
  - \* Perform offset cancel with no external forces acting other than gravity.

(3) Control mode/control characteristics selection (See section [9.1.1.2.](#))

- Set the "control mode" and "control characteristics" numbers. In this example, control mode 1 and control characteristics 1 are used, and therefore the settings are as follows.

[R32TB/R33TB]

<FORCE> PARAMETER	
CONTROL MODE	( 1 )
CONTROL FEATURE	( 1 )
	123
	CLOSE

(4) Force sense control enable operation (See section [9.1.1.3.](#))

- Turn the servo ON after enabling force sense control, and then use JOG operation to move the robot to the insertion complete position.
- JOG operation is stopped automatically if unnecessary force acts on the workpiece. (The buzzer also sounds.)

(5) Force sense monitor (See section [9.1.2.](#))

- Check the force sense data maximum value with the force sense monitor.

## 9.2 Teaching Operation

This Chapter describes teaching operation using force sense control.

### ■□■ Teaching operation precautions ■□■

If using force sense control, the position displayed on the teaching pendant and the actual robot position will differ. This will affect teaching operation, and therefore it is necessary to have a proper understanding of the information in section 9.2.1 before performing teaching operation. Refer to section 9.2.2 for specific details on the operation method.

### 9.2.1 Teaching Position Precautions

When using force sense control, the robot control controls the following two types of position.

	Position Command Type	Description
(1)	Position command	This is a movement command generated by the robot program and JOG operation. It is referenced by the current position display and teaching operations. (Position displayed on T/B)
(2)	Force sense position command	Position command offset by force sense control. When force sense control is enabled, the robot moves based on this command.

By performing teaching operation (teaching operation from T/B or current position reading from RT ToolBox2) from the teaching pendant or RT ToolBox2 while force control is enabled, the position command (1) is taught, and a position different from the actual robot position (2) is taught.

[Example]...If the force control/stiffness control is enabled for the Z-axis

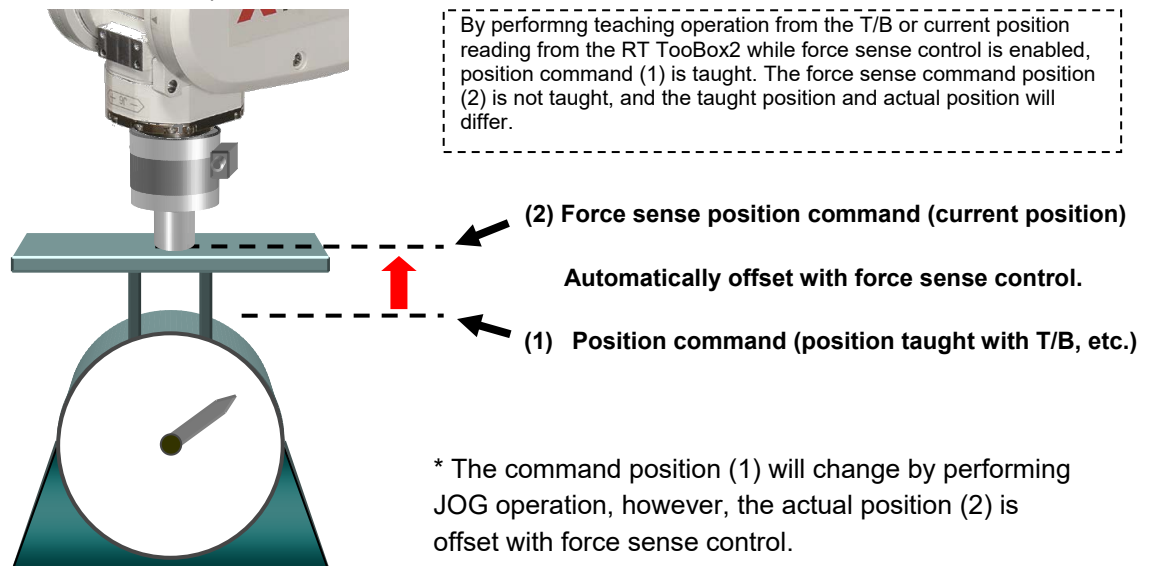

Fig. 9-1: Teaching position precautions

If teaching the actual position, perform teaching operation after changing the position command (position command displayed on T/B, etc.) to the force sense position command (actual position) with the following methods.

<Method 1>...Perform teaching operation after disabling force sense control.

By disabling force sense control, the "command position" changes to the "force sense position command".

<Method 2>...Perform teaching operation after pressing the "Teach pos. search" [Execute] button.

By pressing the "Teach pos. search" [Execute] button while force sense control is enabled, the "command position" is changed to the "force sense position command" while retaining the force sense control status. If performing teaching with force sense control enabled, use this method. (See section [9.2.1.1](#) for details on searching for the teaching position.)



### 9.2.1.1 Teaching Position Search

The "teaching position search" function is used to assist position teaching when force sense control is enabled.

While force control is enabled, a position offset with force sense control is added to the normal position command (position taught with T/B), resulting in a difference between the actual robot position and position displayed on the teaching pendant. By performing the teaching operation, the position displayed on the teaching pendant is registered, and so it is necessary to eliminate this difference before performing the teaching operation. (See section 9.2.1.)

By executing this function, the "position displayed on the teaching pendant" can be replaced with the "actual position" with force sense control still enabled.

[Using teaching position search]

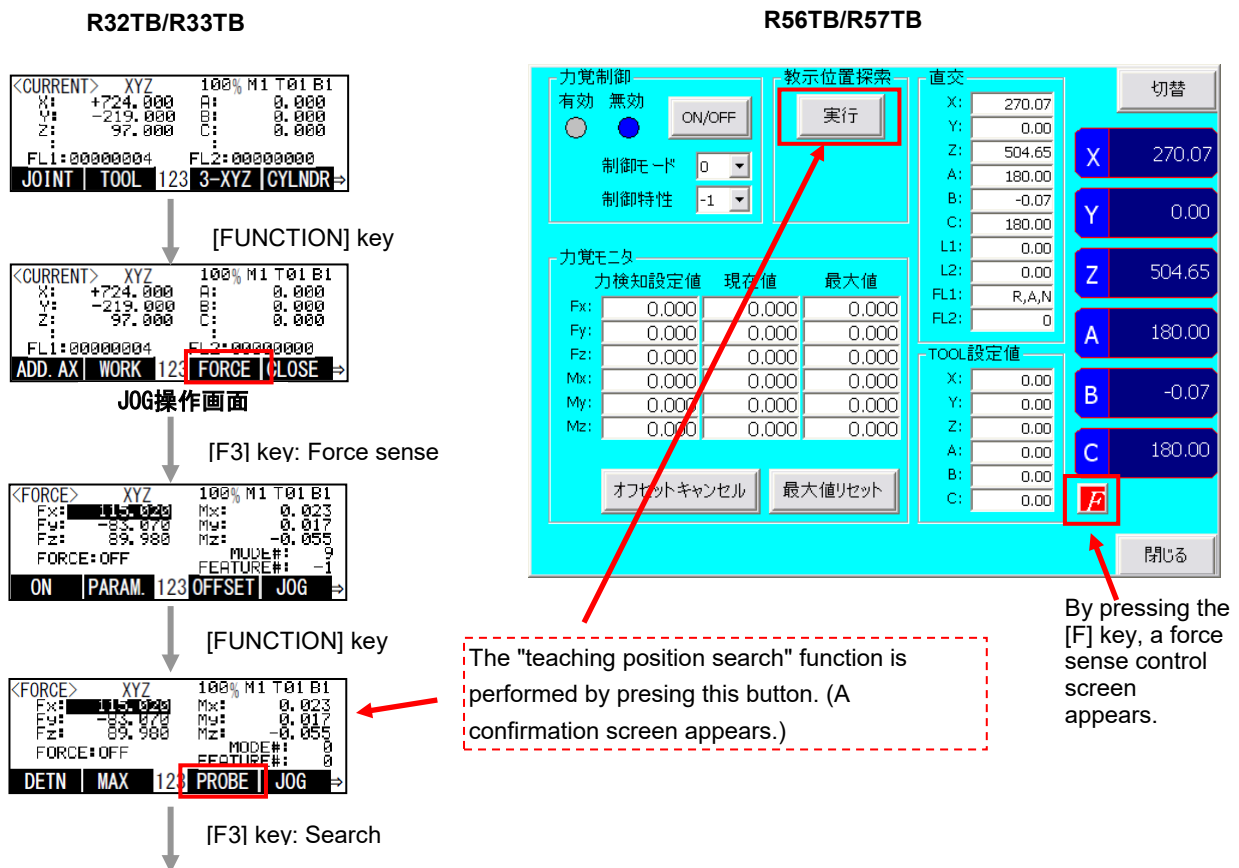

<Precautions when using stiffness control>

The spring center position when using stiffness control is the position displayed on the teaching pendant. The spring center position also moves when performing "teaching position search", and so if a stiffness coefficient of other than 0.0 is set, the robot moves a little. Utilizing this characteristic, a position on which no external force acts can be taught when using stiffness control as shown in the following example.

(Example)..If inserting pins while following the workpiece shape with stiffness control (stiffness coefficient  $\neq 0$ ), external force acts on one side of the pin. By performing "teaching position search" at such times, the robot can be moved in a direction in which no external force acts. There may be cases in which the robot is unable to move to a position in which no external force acts by performing this function only once. In such a case, perform several times while keeping an eye on the force sensor data until the reaction force becomes sufficiently small.

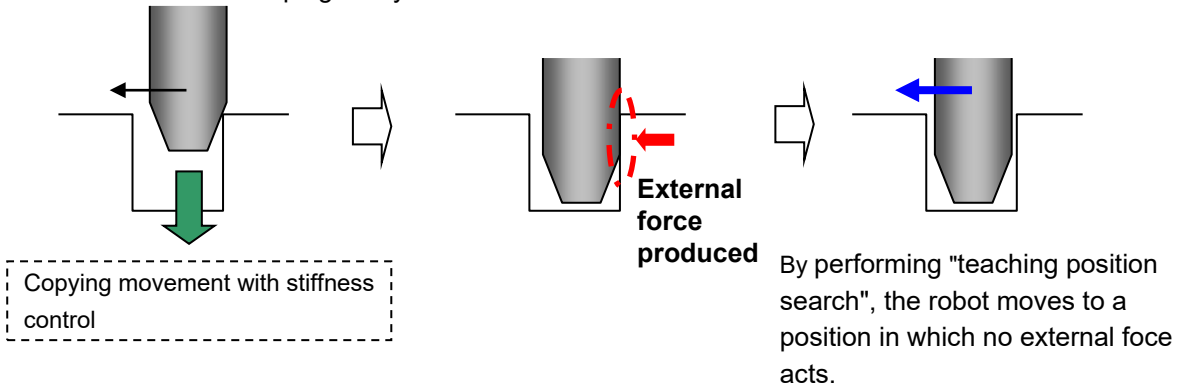

## 9.2.2 Usage Example (Teaching Operation)

### Teaching a Position Pushed with Fixed Force

#### ■ Teaching details

Teach the position at which the spring reaction force becomes 25 N.

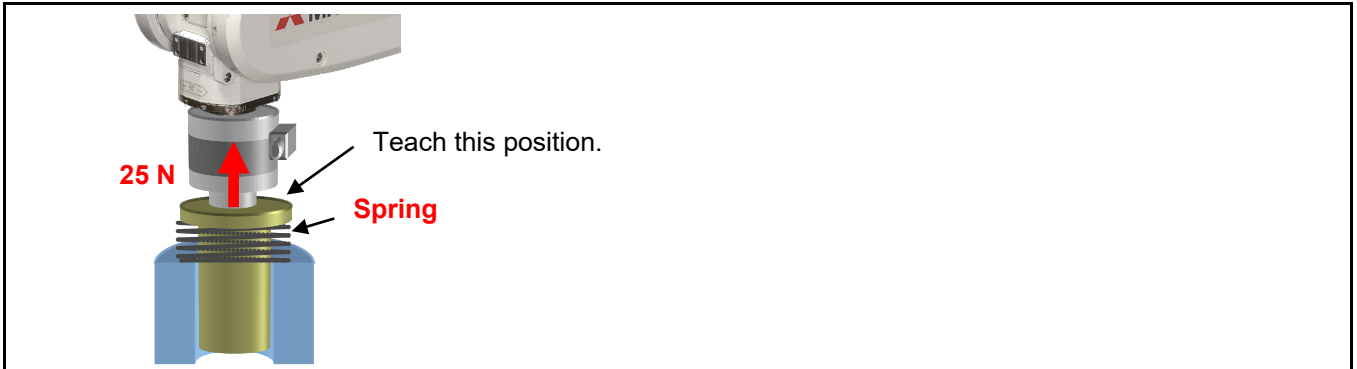

#### ■ Operation procedure

##### (1) Parameter settings

- Select force control for the Z-axis only, and set so that the robot is pushed with a force of 25 N in the tool coordinate system +Z-direction. (See table below.)

Control mode	Force sense control coordinate system	FSCOD01	<b>0</b>
	Force control mode	FSFMD01	<b>+0.00, +0.00, <u>+1.00</u>, +0.00, +0.00, +0.00</b>
	Stiffness coefficient	FSSTF01	+0.00, +0.00, +0.00, +0.00, +0.00, +0.00
	Damping coefficient	FSDMP01	+0.00, +0.00, +0.00, +0.00, +0.00, +0.00
Control characteristics	Force command value	FSFCMD01	<b>+0.00, +0.00, <u>+25.00</u>, +0.00, +0.00, +0.00</b>
	Speed command value	FSSPD01	+0.00, +0.00, +0.00, +0.00, +0.00, +0.00
	Mode switching judgment value	FSSWF01	+0.00, +0.00, +0.00, +0.00, +0.00, +0.00
	Force sense control gain	FSFGN01	<b>+0.00, +0.00, <u>+5.00</u>, +0.00, +0.00, +0.00</b>
	Force detection setting value	FSFLMT01	+0.00, +0.00, +0.00, +0.00, +0.00, +0.00

(\* In this example, settings are specified with parameters, however, setting is also possible with status variables.)

##### (2) Offset cancel operation (See section [9.1.1.1](#).)

- Offset the force sensor zero point after first moving to the push start position (posture) by JOG operation.  
\* Perform offset cancel with no external forces acting other than gravity.

##### (3) Control mode/control characteristics selection (See section [9.1.1.2](#).)

- Set the "control mode" and "control characteristics " numbers.

##### (4) Force sense control enable operation (See section [9.1.1.3](#).)

- Turn the servo ON after enabling force sense control.
- The robot automatically moves to the position in the tool coordinate system +Z-direction at which a reaction force of 25 N can be obtained.

(5) Teaching (The following two teaching methods are available.)

<Method 1>

- Ensure that the force sensor data is  $F_z=25\text{ N}$ , and then disable force sense control with the servo ON.  
(By disabling force sense control, the current position data appears on the teaching pendant.)
- Teach the current position.

<Method 2>

- Ensure that the force sensor data is  $F_z=25\text{ N}$ , and then perform "teaching position search" with the servo ON. By performing "teaching position search", the current position data appears on the teaching pendant.  
(See section [9.2.1.1.](#))
- Teach the current position.

## Teaching the Insertion Position (Using Force Control)

### ■ Teaching details

Teach the ideal insertion position on which no external force acts.

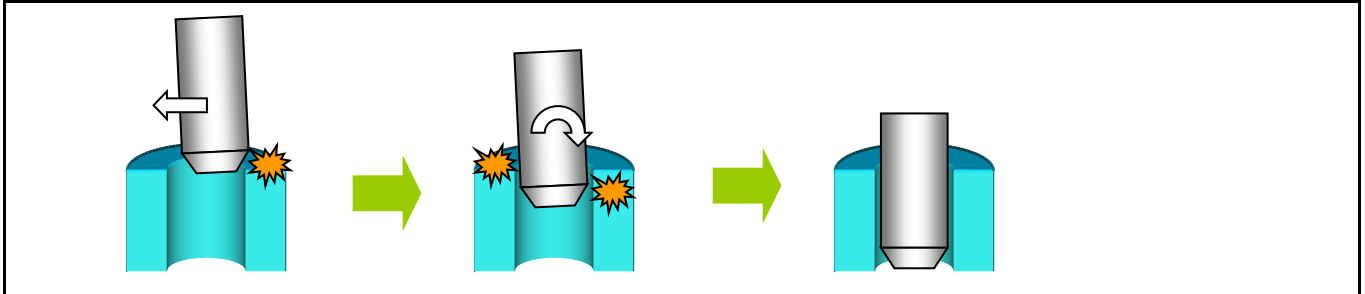

### ■ Operation procedure

#### (1) Parameter settings

- Select all axes and force control, and set the force command so that the robot is pushed with a force of 5 N in the FZt direction, and external force is eliminated for all other axes. ( $F_{Xt}=F_{Yt}=0N$ ,  $M_{Xt}=M_{Yt}=M_{Zt}=0 N\cdot m$ )

Control mode	Force sense control coordinate system	FSCOD01	<b>0</b>
	Force control mode	FSFMD01	<b>+1.00,+1.00,+1.00,+1.00,+1.00,+1.00</b>
	Stiffness coefficient	FSSTF01	+0.00,+0.00,+0.00,+0.00,+0.00,+0.00
	Damping coefficient	FSDMP01	+0.00,+0.00,+0.00,+0.00,+0.00,+0.00
Control characteristics	Force command value	FSFCMD01	<b>+0.00,+0.00,+5.00,+0.00,+0.00,+0.00</b>
	Speed command value	FSSPD01	+0.00,+0.00,+0.00,+0.00,+0.00,+0.00
	Mode switching judgment value	FSSWF01	+0.00,+0.00,+0.00,+0.00,+0.00,+0.00
	Force sense control gain	FSFGN01	<b>+0.50,+0.50,+0.50,+0.10,+0.10,+0.10</b>
	Force detection setting value	FSFLMT01	+0.00,+0.00,+0.00,+0.00,+0.00,+0.00

(\* In this example, settings are specified with parameters, however, setting is also possible with status variables.)

#### (2) Offset cancel operation (See section [9.1.1.1.](#))

- Offset the force sensor zero point after first moving to the insertion start position (posture) by JOG operation.  
\* Perform offset cancel with no external forces acting other than gravity.

#### (3) Control mode/control characteristics selection (See section [9.1.1.2.](#))

- Set the "control mode" and "control characteristics" numbers.

#### (4) Force sense control enable operation (See section [9.1.1.3.](#))

- Turn the servo ON after enabling force sense control (stiffness control).
- The robot automatically moves to the insertion complete position with force control. (The robot moves slowly to the extent that the force sense control gain is lowered.)  
\* Adjust the force command or force sense control gain if required.

#### (5) Teaching (There are two teaching methods.)

<Method 1>

- Ensure that the force sensor data is  $F_z=5N$  and that other axis components are  $0 N / 0 N\cdot m$ , and then disable force sense control with the servo ON.

<Method 2>

- Ensure that the force sensor data is  $F_z=5\text{N}$  and that other axis components are  $0\text{ N} / 0\text{ N}\cdot\text{m}$ , and then perform "teaching position search" with the servo ON. (See section [9.2.1.1.](#))

## Teaching the Insertion Position (Using Stiffness Control)

### ■ Teaching details

Teach the ideal insertion position on which no external force acts.

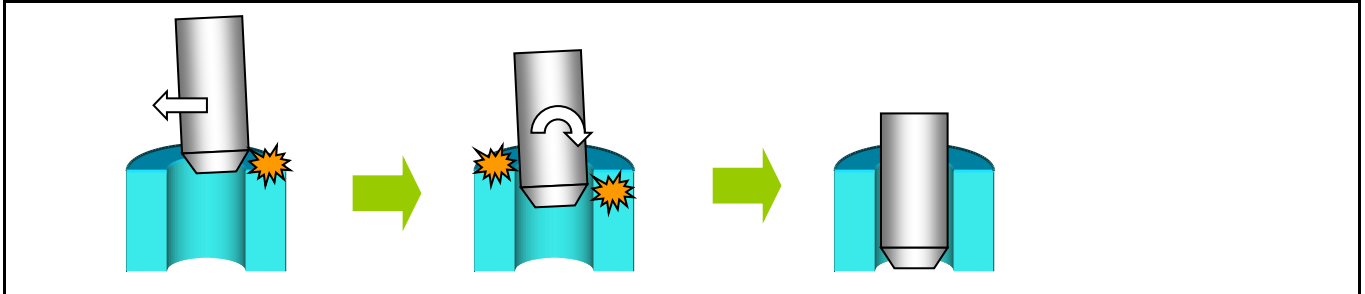

### ■ Operation procedure

#### (1) Parameter settings

- Specify force stiffness control for all axes until the robot becomes suitably soft.

Control mode	Force sense control coordinate system	FSCOD01	0
	Force control mode	FSFMD01	<b>+2.00,+2.00,+2.00,+2.00,+2.00,+2.00</b>
	Stiffness coefficient	FSSTF01	<b>+0.10,+0.10,+0.50,+0.10,+0.10,+0.10</b>
	Damping coefficient	FSDMP01	+0.00,+0.00,+0.00,+0.00,+0.00,+0.00
Control characteristics	Force command value	FSFCMD01	+0.00,+0.00,+0.00,+0.00,+0.00,+0.00
	Speed command value	FSSPD01	+0.00,+0.00,+0.00,+0.00,+0.00,+0.00
	Mode switching judgment value	FSSWF01	+0.00,+0.00,+0.00,+0.00,+0.00,+0.00
	Force sense control gain	FSFGN01	<b>+0.50,+0.50,+0.50,+0.50,+0.50,+0.50</b>
	Force detection setting value	FSFLMT01	+0.00,+0.00,+0.00,+0.00,+0.00,+0.00

(\* In this example, settings are specified with parameters, however, setting is also possible with status variables.)

#### (2) Offset cancel operation (See section [9.1.1.1.](#))

- Offset the force sensor zero point after first moving to the insertion start position (posture) by JOG operation.

\* Perform offset cancel with no external forces acting other than gravity.

#### (3) Control mode/control characteristics selection (See section [9.1.1.2.](#))

- Set the "control mode" and "control characteristics " numbers.

#### (4) Force sense control enable operation (See section [9.1.1.3.](#))

- Turn the servo ON after enabling force sense control (stiffness control).
- Move the robot to the insertion complete position by JOG operation. (Lower OVRD if required.)
- Perform "teaching position search" to move the control center value so that no unnecessary external force acts on the workpiece during movement.

#### (5) Teaching

- Perform "teaching position search" several times while checking the force sense sensor data displayed on the teaching pendant.
- Ensure that the robot is moving to a position at which external force no longer acts, and then teach the current position with force sense control still enabled.

## 9.3 Force Sense Function Screen

### 9.3.1 R56TB/R57TB

If using the force sensor, an [F] button appears in the bottom of the JOG screen. By pressing this button, a force sense control screen appears on the left of the JOG screen.

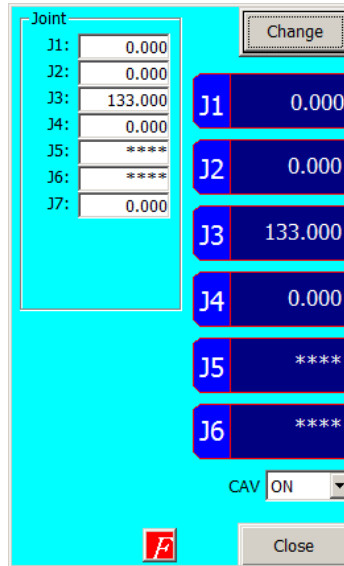

Fig. 9-2 [F] button display

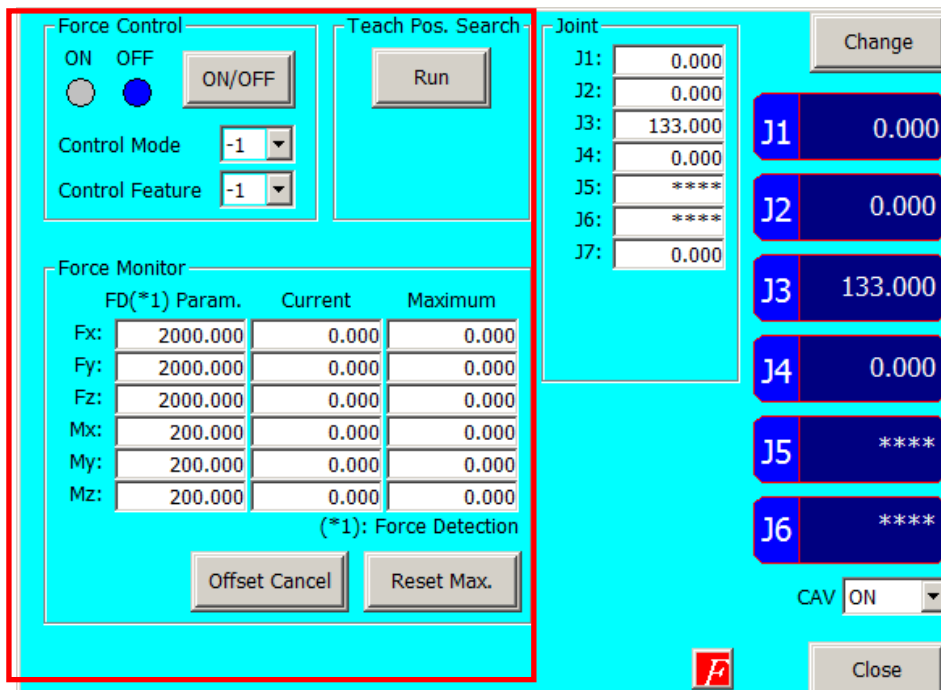
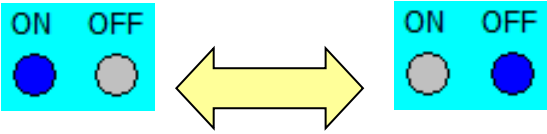
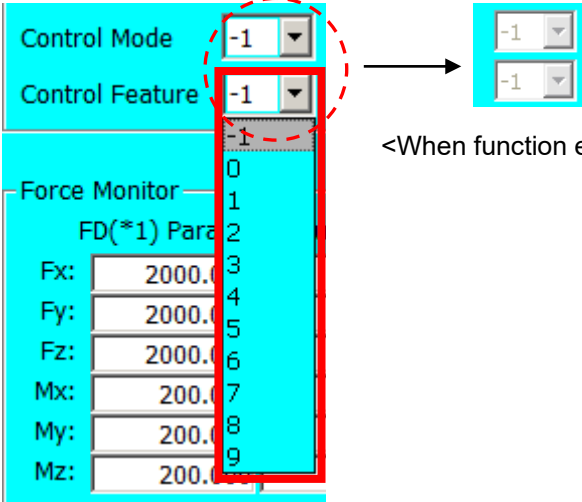
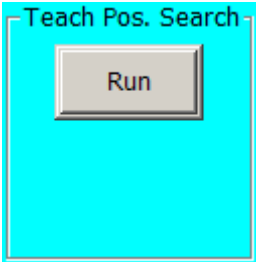



Fig. 9-3: Force sense control extension screen



**Table 9-4: Screen overview**

No.	Screen Control	Overview
1	[F] button	Displays/hides a screen (surrounded by red box in Fig. 9-3) relating to force sense control. (Does not appear if the force sensor interface unit is not connected.)
2	Enable/Disable (ON/OFF)	<ul style="list-style-type: none"> <li>Displays the current force sense control function enabled (ON)/disabled (OFF) status.</li> <li>By pressing the [ON/OFF] button when the force sense control function is disabled, force sense control is enabled with the specified control mode/control characteristics. (Corresponds to the Fsc On command.)</li> <li>By pressing the [ON/OFF] button when the force sense control function is enabled, force sense control is disabled. (Corresponds to the Fsc Off command.)</li> </ul> <div style="text-align: center;">  <p data-bbox="603 801 906 831">&lt;When function enabled&gt;</p> <p data-bbox="1002 801 1315 831">&lt;When function disabled&gt;</p> </div>
3	Control Mode /Control Feature	<ul style="list-style-type: none"> <li>Displays the currently specified control mode/control characteristics.</li> <li>The used control mode/control characteristics can be specified only when the force sense control function is disabled. [Setting range -1 to 9]</li> <li>The control mode/control characteristics cannot be specified when the force sense control function is enabled. (Appears gray.)</li> </ul> <div style="text-align: center;">  <p data-bbox="1002 1193 1305 1223">&lt;When function enabled&gt;</p> <p data-bbox="785 1576 976 1606">&lt;Setting range&gt;</p> </div>
4	Teach Pos. Search	<ul style="list-style-type: none"> <li>By pressing the [Execute] button the system performs teaching position search. This is used to perform accurate contact position teaching.</li> </ul> <div style="text-align: center;">  </div>

No.	Screen Control	Overview
5	Force Monitor	<ul style="list-style-type: none"> <li>Displays the force detection setting value (corresponds to parameters FSFLMT01 to 09 and status variables P_FsFLm0 and P_FsFlm1) specified at "Control characteristics "</li> </ul>
6	Current	<ul style="list-style-type: none"> <li>Displays the current force sensor data (corresponds to status variable P_FsCurD.)                             <ul style="list-style-type: none"> <li>* Displays the value converted to the force sense coordinate system (Tool/XYZ).</li> </ul> </li> <li>Displays the current value when the force sense control function is disabled .</li> <li>If the force sensor data exceeds the detected setting value during JOG operation, the background color of the applicable data changes, and the buzzer sounds.</li> </ul> <div style="text-align: center; margin-top: 10px;">  <p style="margin: 0;">Fx: -171.500 -171.500 -171.500</p> <p style="margin: 0;">&lt;When detection setting value over&gt;</p> </div>
7	Maximum	<ul style="list-style-type: none"> <li>Displays the force sensor data maximum value (corresponds to status variable P_FsMaxD) during force sense control.</li> <li>* The maximum value is reset with the maximum value reset operation or offset cancel operation.</li> </ul>
8	Offset Cancel	<ul style="list-style-type: none"> <li>Cancels the force sensor offset component (zero point offset). If sensor data is not 0 with no external force acting on the sensor, it is necessary to perform offset cancel.</li> <li>Offsets cannot be cancelled when the force sense control function is disabled. (Appears gray.)</li> </ul>
9	Reset Max.	<ul style="list-style-type: none"> <li>Resets the force sense data maximum value.</li> </ul>

### 9.3.2 R32TB/R33TB

Force sense function related screens are displayed by selecting from the extension function menu screen or by changing function from the JOG screen. These screens appear as follows on the R32TB.

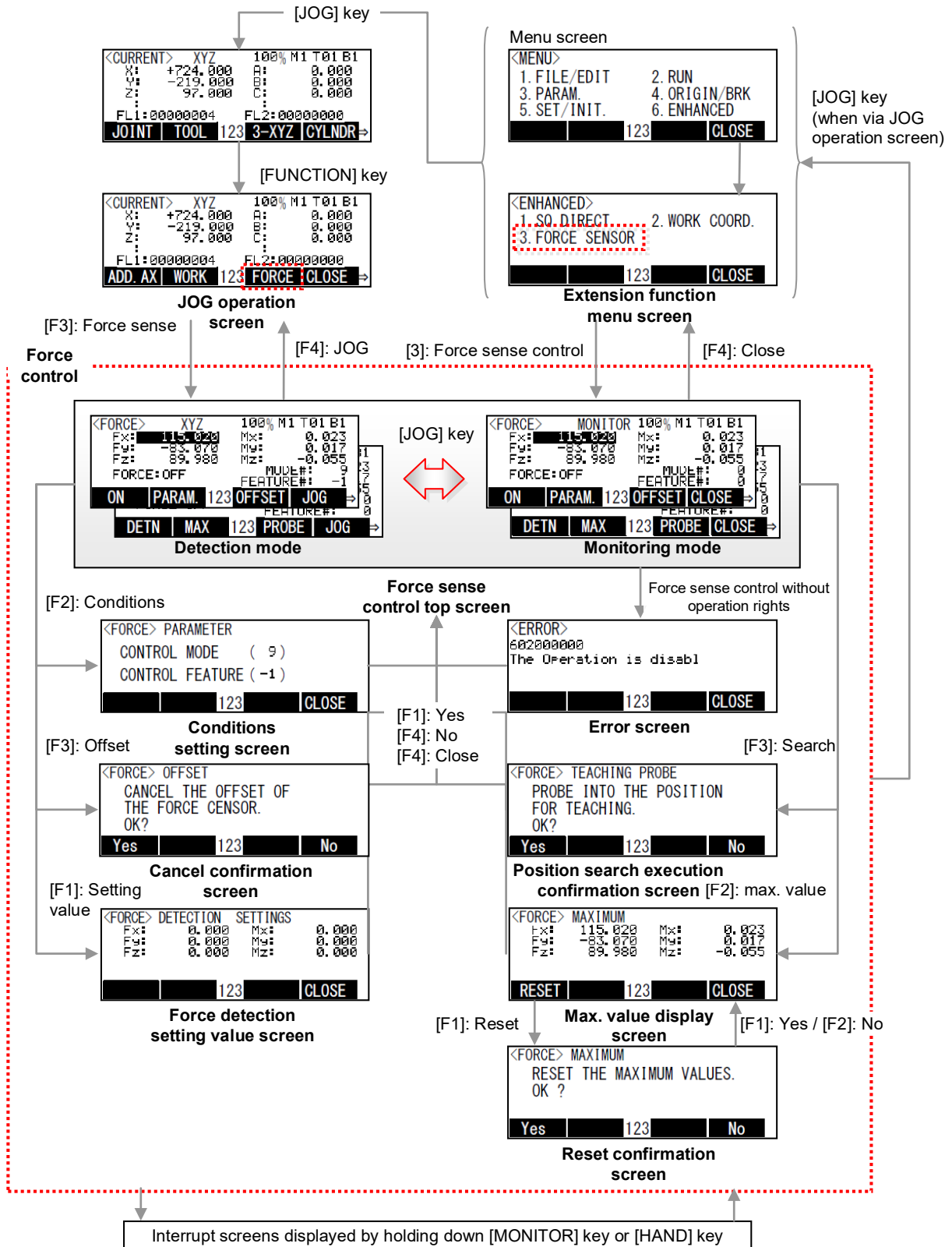
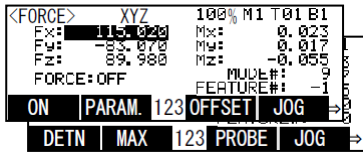
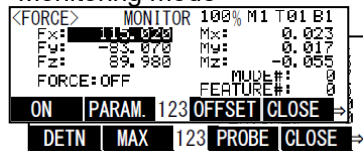

Fig. 9-4: Force sense control related R32TB/R33TB screen transition

**Table 9-5: Screen overview**

Screen Name	Overview																								
Force sense control top screen	<p><b>&lt;Detection mode&gt;</b></p>  <p>The screen changes by pressing the [FUNCTION] key.</p> <ul style="list-style-type: none"> <li>Detection mode is enabled when changing from the JOG operation screen.</li> <li>By operating the [-X] [+X] [-Y] [+Y] [-Z] [+Z] [-A] [+A] [-B] [+B] [-C] [+C] keys in detection mode, JOG operation can be performed. (* Operation rights required.)</li> <li>JOG operation types correspond to the JOG operation screen immediately before changing to the force sense control top screen. (The selected JOG operation type appears in the center of the screen.)</li> </ul> <p><b>&lt;Monitoring mode&gt;</b></p>  <p>The screen changes by pressing the [FUNCTION] key.</p> <ul style="list-style-type: none"> <li>Monitoring mode is enabled when changing from the extension function menu screen.</li> <li>JOG operation is not possible in monitoring mode.</li> <li>"Monitor" appears in the top center of the screen.</li> </ul> <table border="1" style="width: 100%; border-collapse: collapse;"> <thead> <tr> <th style="background-color: #d9ead3;">Screen Display</th> <th style="background-color: #d9ead3;">Meaning</th> </tr> </thead> <tbody> <tr> <td>"Fx" - "Mz"</td> <td>Displays the current force sensor data (corresponding to status variable P_FsCurD.) * Displays values converted to the force sense coordinate system (Tool/XYZ). If the force sensor data exceeds the detection setting value during JOG operation, the background color of the exceeded data changes and the buzzer sounds.</td> </tr> <tr> <td>"Force Sense"</td> <td>Displays the current force sense control function enabled (ON)/disabled (OFF) status.</td> </tr> <tr> <td>"Mode No."</td> <td>Displays the currently specified control mode No.</td> </tr> <tr> <td>"Feature No."</td> <td>Displays the currently displayed control characteristics No.</td> </tr> </tbody> </table> <table border="1" style="width: 100%; border-collapse: collapse;"> <thead> <tr> <th style="background-color: #d9ead3;">Function</th> <th style="background-color: #d9ead3;">Description</th> </tr> </thead> <tbody> <tr> <td rowspan="2">[F1]</td> <td>ON/OFF Changes the force sense control function enabled/disabled status. (* Operation rights required.) The "Mode No." and "Feature No." values are used for the control mode and control characteristics. Offset cancel is not performed.</td> </tr> <tr> <td>Setting Changes to the force detection setting value screen.</td> </tr> <tr> <td rowspan="2">[F2]</td> <td>Condition Changes to the conditions setting screen if force sense control is disabled.</td> </tr> <tr> <td>Max. Value Changes to the maximum value display screen.</td> </tr> <tr> <td rowspan="2">[F3]</td> <td>Offset Changes to the cancel confirmation screen.</td> </tr> <tr> <td>Search Changes to the position search execution confirmation screen.</td> </tr> <tr> <td rowspan="2">[F4]</td> <td>JOG Changes to the JOG operation screen.</td> </tr> <tr> <td>Close Changes to the extension function menu screen.</td> </tr> </tbody> </table>	Screen Display	Meaning	"Fx" - "Mz"	Displays the current force sensor data (corresponding to status variable P_FsCurD.) * Displays values converted to the force sense coordinate system (Tool/XYZ). If the force sensor data exceeds the detection setting value during JOG operation, the background color of the exceeded data changes and the buzzer sounds.	"Force Sense"	Displays the current force sense control function enabled (ON)/disabled (OFF) status.	"Mode No."	Displays the currently specified control mode No.	"Feature No."	Displays the currently displayed control characteristics No.	Function	Description	[F1]	ON/OFF Changes the force sense control function enabled/disabled status. (* Operation rights required.) The "Mode No." and "Feature No." values are used for the control mode and control characteristics. Offset cancel is not performed.	Setting Changes to the force detection setting value screen.	[F2]	Condition Changes to the conditions setting screen if force sense control is disabled.	Max. Value Changes to the maximum value display screen.	[F3]	Offset Changes to the cancel confirmation screen.	Search Changes to the position search execution confirmation screen.	[F4]	JOG Changes to the JOG operation screen.	Close Changes to the extension function menu screen.
Screen Display	Meaning																								
"Fx" - "Mz"	Displays the current force sensor data (corresponding to status variable P_FsCurD.) * Displays values converted to the force sense coordinate system (Tool/XYZ). If the force sensor data exceeds the detection setting value during JOG operation, the background color of the exceeded data changes and the buzzer sounds.																								
"Force Sense"	Displays the current force sense control function enabled (ON)/disabled (OFF) status.																								
"Mode No."	Displays the currently specified control mode No.																								
"Feature No."	Displays the currently displayed control characteristics No.																								
Function	Description																								
[F1]	ON/OFF Changes the force sense control function enabled/disabled status. (* Operation rights required.) The "Mode No." and "Feature No." values are used for the control mode and control characteristics. Offset cancel is not performed.																								
	Setting Changes to the force detection setting value screen.																								
[F2]	Condition Changes to the conditions setting screen if force sense control is disabled.																								
	Max. Value Changes to the maximum value display screen.																								
[F3]	Offset Changes to the cancel confirmation screen.																								
	Search Changes to the position search execution confirmation screen.																								
[F4]	JOG Changes to the JOG operation screen.																								
	Close Changes to the extension function menu screen.																								

Screen Name	Overview																						
Force detection setting value screen	<div style="border: 1px solid black; padding: 5px; margin-bottom: 10px;"> <p>&lt;FORCE&gt; DETECTION SETTINGS</p> <table style="width: 100%; border-collapse: collapse;"> <tr> <td style="width: 33%;">Fx#:</td><td style="width: 33%;">0.000</td><td style="width: 33%;">Mx#:</td><td style="width: 33%;">0.000</td> </tr> <tr> <td>Fy#:</td><td>0.000</td><td>My#:</td><td>0.000</td> </tr> <tr> <td>Fz#:</td><td>0.000</td><td>Mz#:</td><td>0.000</td> </tr> </table> <p style="text-align: right;">123    CLOSE</p> </div> <table border="1" style="width: 100%; border-collapse: collapse;"> <thead> <tr> <th style="width: 30%;">Screen Display</th> <th>Meaning</th> </tr> </thead> <tbody> <tr> <td>"Fx" - "Mz"</td> <td>Displays the current force detection setting value specified with the control characteristics.</td> </tr> </tbody> </table> <table border="1" style="width: 100%; border-collapse: collapse;"> <thead> <tr> <th style="width: 30%;">Function</th> <th>Description</th> </tr> </thead> <tbody> <tr> <td>[F4] Close</td> <td>Changes to the force sense control top screen.</td> </tr> </tbody> </table>	Fx#:	0.000	Mx#:	0.000	Fy#:	0.000	My#:	0.000	Fz#:	0.000	Mz#:	0.000	Screen Display	Meaning	"Fx" - "Mz"	Displays the current force detection setting value specified with the control characteristics.	Function	Description	[F4] Close	Changes to the force sense control top screen.		
Fx#:	0.000	Mx#:	0.000																				
Fy#:	0.000	My#:	0.000																				
Fz#:	0.000	Mz#:	0.000																				
Screen Display	Meaning																						
"Fx" - "Mz"	Displays the current force detection setting value specified with the control characteristics.																						
Function	Description																						
[F4] Close	Changes to the force sense control top screen.																						
Conditions setting screen	<div style="border: 1px solid black; padding: 5px; margin-bottom: 10px;"> <p>&lt;FORCE&gt; PARAMETER</p> <p>CONTROL MODE ( 9 )</p> <p>CONTROL FEATURE (-1)</p> <p style="text-align: right;">123    CLOSE</p> </div> <table border="1" style="width: 100%; border-collapse: collapse;"> <thead> <tr> <th style="width: 30%;">Screen Display</th> <th>Meaning</th> </tr> </thead> <tbody> <tr> <td>"Control Mode"</td> <td>Displays/sets the control mode No. By pressing the [EXE] key, the condition No. Set in parentheses ( ) is updated.</td> </tr> <tr> <td>"Control Feature"</td> <td>Displays/sets the control characteristics No. By pressing the [EXE] key, the condition No. Set in parentheses ( ) is updated.</td> </tr> </tbody> </table> <table border="1" style="width: 100%; border-collapse: collapse;"> <thead> <tr> <th style="width: 30%;">Function</th> <th>Description</th> </tr> </thead> <tbody> <tr> <td>[F4] Close</td> <td>Changes to the force sense control top screen.</td> </tr> </tbody> </table>	Screen Display	Meaning	"Control Mode"	Displays/sets the control mode No. By pressing the [EXE] key, the condition No. Set in parentheses ( ) is updated.	"Control Feature"	Displays/sets the control characteristics No. By pressing the [EXE] key, the condition No. Set in parentheses ( ) is updated.	Function	Description	[F4] Close	Changes to the force sense control top screen.												
Screen Display	Meaning																						
"Control Mode"	Displays/sets the control mode No. By pressing the [EXE] key, the condition No. Set in parentheses ( ) is updated.																						
"Control Feature"	Displays/sets the control characteristics No. By pressing the [EXE] key, the condition No. Set in parentheses ( ) is updated.																						
Function	Description																						
[F4] Close	Changes to the force sense control top screen.																						
Maximum value display screen	<div style="border: 1px solid black; padding: 5px; margin-bottom: 10px;"> <p>&lt;FORCE&gt; MAXIMUM</p> <table style="width: 100%; border-collapse: collapse;"> <tr> <td style="width: 33%;">Fx#:</td><td style="width: 33%;">115.020</td><td style="width: 33%;">Mx#:</td><td style="width: 33%;">0.023</td> </tr> <tr> <td>Fy#:</td><td>-03.070</td><td>My#:</td><td>0.017</td> </tr> <tr> <td>Fz#:</td><td>03.980</td><td>Mz#:</td><td>-0.055</td> </tr> </table> <p style="text-align: right;">RESET    123    CLOSE</p> </div> <table border="1" style="width: 100%; border-collapse: collapse;"> <thead> <tr> <th style="width: 30%;">Screen Display</th> <th>Meaning</th> </tr> </thead> <tbody> <tr> <td>"Fx" - "Mz"</td> <td>Displays the maximum force sensor data value during force sense control. (Corresponds to status variable P_FsMaxD.)</td> </tr> </tbody> </table> <table border="1" style="width: 100%; border-collapse: collapse;"> <thead> <tr> <th style="width: 30%;">Function</th> <th>Description</th> </tr> </thead> <tbody> <tr> <td>[F1] Reset</td> <td>Changes to the reset confirmation screen.</td> </tr> <tr> <td>[F4] Close</td> <td>Changes to the force sense control top screen.</td> </tr> </tbody> </table>	Fx#:	115.020	Mx#:	0.023	Fy#:	-03.070	My#:	0.017	Fz#:	03.980	Mz#:	-0.055	Screen Display	Meaning	"Fx" - "Mz"	Displays the maximum force sensor data value during force sense control. (Corresponds to status variable P_FsMaxD.)	Function	Description	[F1] Reset	Changes to the reset confirmation screen.	[F4] Close	Changes to the force sense control top screen.
Fx#:	115.020	Mx#:	0.023																				
Fy#:	-03.070	My#:	0.017																				
Fz#:	03.980	Mz#:	-0.055																				
Screen Display	Meaning																						
"Fx" - "Mz"	Displays the maximum force sensor data value during force sense control. (Corresponds to status variable P_FsMaxD.)																						
Function	Description																						
[F1] Reset	Changes to the reset confirmation screen.																						
[F4] Close	Changes to the force sense control top screen.																						
Reset confirmation screen	<div style="border: 1px solid black; padding: 5px; margin-bottom: 10px;"> <p>&lt;FORCE&gt; MAXIMUM</p> <p>RESET THE MAXIMUM VALUES.</p> <p>OK ?</p> <p style="text-align: right;">Yes    123    No</p> </div> <table border="1" style="width: 100%; border-collapse: collapse;"> <thead> <tr> <th style="width: 30%;">Function</th> <th>Description</th> </tr> </thead> <tbody> <tr> <td>[F1] Yes</td> <td>Resets the maximum force sensor data value during force sense control to 0. (* Operation rights required.) Changes to the maximum value display screen after resetting.</td> </tr> <tr> <td>[F4] No</td> <td>Changes to the maximum value display screen.</td> </tr> </tbody> </table>	Function	Description	[F1] Yes	Resets the maximum force sensor data value during force sense control to 0. (* Operation rights required.) Changes to the maximum value display screen after resetting.	[F4] No	Changes to the maximum value display screen.																
Function	Description																						
[F1] Yes	Resets the maximum force sensor data value during force sense control to 0. (* Operation rights required.) Changes to the maximum value display screen after resetting.																						
[F4] No	Changes to the maximum value display screen.																						

Screen Name	Overview						
Cancel confirmation screen	<div style="border: 1px solid black; padding: 5px; width: fit-content;"> <p>&lt;FORCE&gt; OFFSET                      CANCEL THE OFFSET OF                      THE FORCE SENSOR.                      OK?                      Yes <input type="text" value="123"/> No</p> </div>						
	<table border="1" style="width: 100%;"> <thead> <tr> <th style="width: 10%;">Function</th> <th style="width: 10%;">Description</th> </tr> </thead> <tbody> <tr> <td>[F1] Yes</td> <td>                     Cancels the force sensor offset component.                      If the sensor data is not 0 with no external force acting on the sensor, it is necessary to perform offset cancel.                      (* Operation rights required.)                      An error occurs when force sense control is enabled and the servo is ON.                      Changes to the force sense control top screen after canceling.                 </td> </tr> <tr> <td>[F4] No</td> <td>Changes to the force sense control top screen.</td> </tr> </tbody> </table>	Function	Description	[F1] Yes	Cancels the force sensor offset component. If the sensor data is not 0 with no external force acting on the sensor, it is necessary to perform offset cancel. (* Operation rights required.) An error occurs when force sense control is enabled and the servo is ON. Changes to the force sense control top screen after canceling.	[F4] No	Changes to the force sense control top screen.
	Function	Description					
[F1] Yes	Cancels the force sensor offset component. If the sensor data is not 0 with no external force acting on the sensor, it is necessary to perform offset cancel. (* Operation rights required.) An error occurs when force sense control is enabled and the servo is ON. Changes to the force sense control top screen after canceling.						
[F4] No	Changes to the force sense control top screen.						
[F4] No	Changes to the force sense control top screen.						
Position search execution confirmation screen	<div style="border: 1px solid black; padding: 5px; width: fit-content;"> <p>&lt;FORCE&gt; TEACHING PROBE                      PROBE INTO THE POSITION                      FOR TEACHING.                      OK?                      Yes <input type="text" value="123"/> No</p> </div>						
	<table border="1" style="width: 100%;"> <thead> <tr> <th style="width: 10%;">Function</th> <th style="width: 10%;">Description</th> </tr> </thead> <tbody> <tr> <td>[F1] Yes</td> <td>                     Performs the teaching position search function.                      This is used when teaching the contact position.                      (* Operation rights required.)                      Changes to the force sense control top screen after processing.                 </td> </tr> <tr> <td>[F4] No</td> <td>Changes to the force sense control top screen.</td> </tr> </tbody> </table>	Function	Description	[F1] Yes	Performs the teaching position search function. This is used when teaching the contact position. (* Operation rights required.) Changes to the force sense control top screen after processing.	[F4] No	Changes to the force sense control top screen.
	Function	Description					
[F1] Yes	Performs the teaching position search function. This is used when teaching the contact position. (* Operation rights required.) Changes to the force sense control top screen after processing.						
[F4] No	Changes to the force sense control top screen.						
[F4] No	Changes to the force sense control top screen.						

# 10 Application Examples

## Part Assembly Work (Force Control)

### ■ Operation details

Assembles parts so that no unnecessary force acts on the parts when following the part fitting shape.

- The robot is controlled using force control so that the force acting in the X- and Y- directions is 0.0 N.
- The work complete condition is defined in the Mo trigger, and work is completed by interrupt processing.

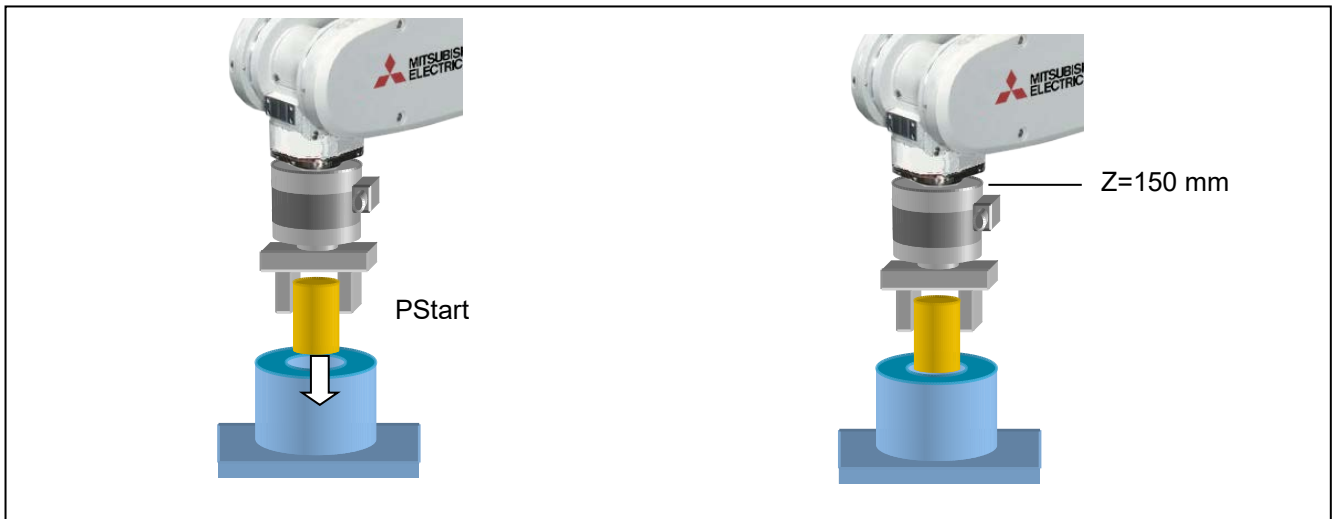

### ■ Program example <Sample program FA01.prg>

<pre>[Control mode (0)] P_FsStf0 = (+0.00,+0.00,+0.00,+0.00,+0.00,+0.00)(0,0) P_FsDmp0 = (+0.00,+0.00,+0.00,+0.00,+0.00,+0.00)(0,0) <b>P_FsMod0 = (+1.00,+1.00,+1.00,+0.00,+0.00,+0.00)(0,0)</b> M_FsCod0 = 0 [Control characteristics (0)] <b>P_FsGn0 = (+3.00,+3.00,+3.00,+0.00,+0.00,+0.00)(0,0)</b> P_FsFLm0 = (+0.00,+0.00,+0.00,+0.00,+0.00,+0.00)(0,0) <b>P_FsFCd0 = (+0.00,+0.00,+5.00,+0.00,+0.00,+0.00)(0,0)</b> P_FsSpd0=(+0.00,+0.00,+10.00,+0.00,+0.00,+0.00)(0,0) <b>P_FsSwF0=(+0.00,+0.00,+4.00,+0.00,+0.00,+0.00)(0,0)</b> *** &lt;Assembly work&gt; *** Def MoTrg 1, ((P_Fbc.Z &lt;= 151) AND (P_FsCurD.Z &gt; 4.8)) Def Act 1,M_MoTrg(1)=1 GoTo *XOK,F Mvs PStart SetMoTrg 1 Fsc On,0,0,1  Act 1=1 M_Timer(1)=0 *LBL1:If M_Timer(1) &lt; 5000 Then Goto *LBL1 Fsc Off Error 9100  End *** &lt;Work completed&gt; *** *XOK' Act 1=0 SetMoTrg 0 Fsc Off HOpen 1 P2=P_Fbc P2.Z=P2.Z+100  Mvs P2 End</pre>	<pre>'Stiffness coefficient [N/mm] 'Damping coefficient '<b>Force control mode (X,Y,Z-axis force control)</b> 'Force sense control coordinate system (tool)  '<b>Force control gain [µm/N]</b> 'Force detection setting value [N] '<b>Force control (X,Y-axis: 0.0 N, Z-axis: 5.0 N)</b> '<b>Sets speed control mode speed. (Z-axis: 10 mm/s)</b> '<b>Sets force/speed judgment value.</b>  'Work complete conditions defined for Mo trigger 1. 'Mo trigger 1 defined as interrupt condition. 'Robot moves over insertion position. 'Mo trigger 1 is enabled. 'Force sense control is enabled. (Insertion started with force control.) 'Interrupt processing 1 is enabled. 'Timer clear 'Waits for timeout time of 5 seconds. 'Force sense control is disabled. 'Error occurs if insertion work not complete within 5 seconds.  'Insertion work complete interrupt processing  'Mo trigger is enabled. 'Force sense control is disabled.  'Feedback position acquisition 'Target position determined as position +100 mm in Z-direction from current position.</pre>
--	--

■Description

- 1) With force control, the robot is set to push with a force of 0.0 N in the X- and Y-directions, and 5.0 N in the Z-direction. Furthermore, if the reaction force in the Z-direction is less than 4 N, the robot moves at a speed of 10 mm/s in speed priority mode.
- 2) Work complete conditions are defined for Mo trigger 1 with the Def MoTrg command. (In this example, when  $Z \leq 151$  mm and  $F_{zt} > 4.8$  N, it is judged that insertion work is complete.)
- 3) After moving to the assembly start position, by enabling Mo trigger 1 followed by force sense control, insertion work is started automatically.
- 4) If insertion work is not completed within 5 seconds of work starting, a 9100 error is output and insertion work is stopped.
- 5) If insertion work is completed successfully,  $M\_MoTrg(1)=1$  and interrupt processing (label: \*XOK) is performed.



## Phase Focusing Push

### ■ Operation details

The robot inserts into a metal axis while searching for a d-cut gear phase.

- The robot rotates in the C-axis direction while pushing softly in the Z-direction with robot stiffness softened by stiffness control.
- When the gear and metal axis phases match, the moment around the Z-axis (Mz) increases.
- The Mz increase is detected and push work is started.

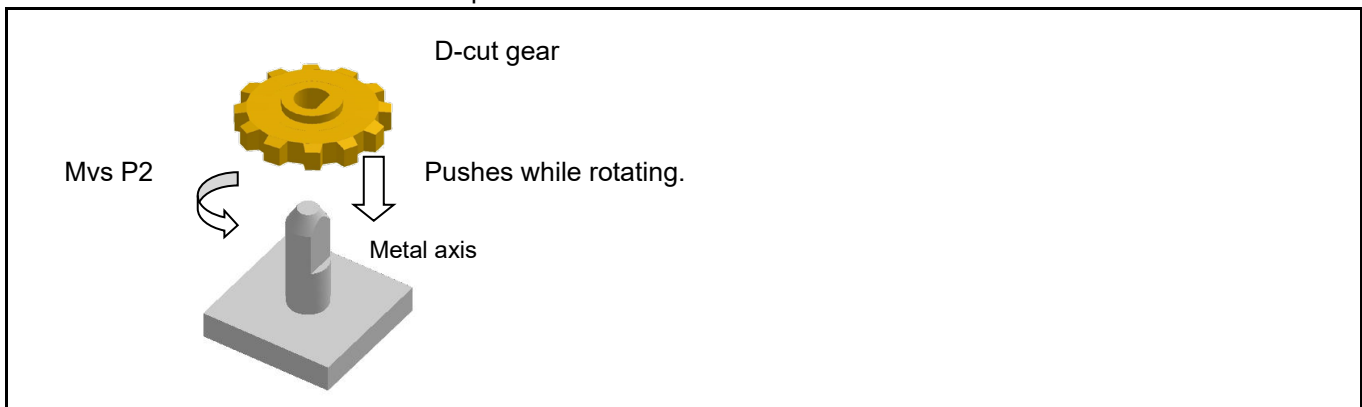

### ■ Program example <Sample program FA02.prg>

[Control mode (0)]	
<b>P_FsStf0 = (+0.00,+0.00,+3.00,+0.00,+0.00,+0.50)(0,0)</b>	<b>'Stiffness coefficient [N/mm]</b>
P_FsDmp0 = (+0.00,+0.00,+0.00,+0.00,+0.00,+0.00)(0,0)	'Damping coefficient
<b>P_FsMod0 = (+2.00,+2.00,+2.00,+0.00,+0.00,+2.00)(0,0)</b>	<b>'Force control mode (X,Y,Z,C: stiffness control)</b>
M_FsCod0 = 0	'Force sense control coordinate system (tool)
[Control characteristics (0)]	
<b>P_FsGn0 = (+2.50,+2.50,+2.50,+0.00,+0.00,+2.50)(0,0)</b>	<b>'Force control gain [<math>\mu\text{m/N}</math>]</b>
<b>P_FsFLm0 = (+0.00,+0.00,+0.00,+0.00,+0.00,+0.05)(0,0)</b>	<b>'Force detection setting value [N] (Mz=0.05Nm)</b>
P_FsFCd0 = (+0.00,+0.00,+0.00,+0.00,+0.00,+0.00)(0,0)	'Force control
P_FsSpd0=(+0.00,+0.00,+0.00,+0.00,+0.00,+0.00)(0,0)	'Sets speed control mode speed.
P_FsSwF0=(+0.00,+0.00,+0.00,+0.00,+0.00,+0.00)(0,0)	'Sets force/speed judgment value.
[Control characteristics (-1)]	
<b>P_FsGn1 = (+2.50,+2.50,+0.00,+0.00,+0.00,+3.00)(0,0)</b>	<b>'Force control gain [<math>\mu\text{m/N}</math>] (Z axis=0.0[<math>\mu\text{m/N}</math>])</b>
P_FsFLm1 = (+0.00,+0.00,+0.00,+0.00,+0.00,+0.00)(0,0)	'Force detection setting value [N]
P_FsFCd1 = (+0.00,+0.00,+0.00,+0.00,+0.00,+0.00)(0,0)	'Force control
P_FsSpd1=(+0.00,+0.00,+0.00,+0.00,+0.00,+0.00)(0,0)	'Sets speed control mode speed. (Z-axis: 10mm/s)
P_FsSwF1=(+0.00,+0.00,+0.00,+0.00,+0.00,+0.00)(0,0)	'Sets force/speed judgment value.
*** <Assembly work> ***	
Mvs PStart	' Robot moves over insertion position.
Dly 1	
Ovrd 5	
Fsc On,0,0,1	'X,Y,Z,C-axes set to stiffness control.
Mvs P1	'Robot moves to pos. pushed approx. 1 mm from assembly
start pos.	
Mvs P2 Wthif M_FsLmtR.C>0, Skip	'C-axis is rotated and skip occurs when Mz $\geq$ 0.5 N·m.
If M_SkipCq = 0 Then *LERR	'Proceeds to failure processing if skip processing not
performed.	
FsGChg 0,10,-1	""Control characteristics " changed to "-1".
Mvs ,10	'Tool moved 10 mm in +Z-direction.
HOpen 1	
Fsc Off	
Mvs PStart	
End	
*LERR	'Error processing
Error 9100	
End	

■ Description

- 1) The robot is set to control the X-, Y-, Z-, and C-axes softly with stiffness control. The force detection setting value is  $Mz = 0.05 \text{ N}\cdot\text{m}$ .
- 2) Force control is enabled, and the robot moves to a position approximately 1 mm below of the insertion start position. (MvsP1)
- 3) The C-axis is rotated with the Mvs command. If a moment of  $Mz \geq 0.05 \text{ N}\cdot\text{m}$  is detected during operation using a Wthif sub-clause, operation is stopped and skip processing is performed at the next step.
- 4) The gear is twisted in the C-axis direction while pushing in the Z-direction, and therefore when the D-cut gear and metal axis phases match,  $Mz$  increases. Wthif sub-clause conditions are established, and therefore rotation is stopped and skip processing is performed for the next command. (If skip processing is not performed, the system determines that phase detection has failed and error processing is performed.)
- 5) Control characteristics "0" is changed to "-1" using the FsGChg command so that the Z-axis control gain becomes 0.0. (If the control gain is 0, the robot is not controlled softly even if stiffness control is selected. Control will be the equivalent of position control.)
- 6) The robot moves 10 mm in the tool coordinate system Z-direction and assembly work is completed.

# 11 Language Specifications

This Chapter describes specifications for force sense control function related to MELFA-BASIC V commands and status variables.

## ■□■ Precautions when using status variables ■□■

By directly referencing P variable A-, B-, and C-axis values as component data, they are read as radian unit values. If reading values for each component and creating a program, unit conversion is required. (See following example.)

<Example>

By replacing P\_FsLmtR = (0, 0, 1, 2, 0, 0, 0, 0) A-axis component data for M1 such as M1 = P\_FsLmtR.A, M1 is replaced not by 2, but by 0.034906 ( $=2 \times \pi \div 180$ ). To replace M1 with 2, use the Deg function.

M1% = Deg(P\_FsLmtR.A)

By changing parameter PRGMDEG setting to 1, the unit system when the P variable rotational axis component data is referenced is deg, and therefore there is no need to use the Deg function. (Refer to instruction manual "Detailed Description of Functions and Operation" for details on the Deg function and parameter PRGMDEG.)

## 11.1 Commands Relating to Force Sense Control Function

MELFA-BASIC V commands relating to the force sense control function are described below.

**Table 11-1: Force sense control commands**

No.	Command	Function Overview
1	Fsc On	Enables the force sense control function using force sensor.
2	Fsc Off	Disables the force sense control function using force sensor.
3	FsGChg	Changes control characteristics for force sense control during operation.
4	FsCTrg	Sets force sense control characteristics switching with the Mo trigger.

**Fsc On****[Function]**

Enables the force sense control function using force sensor.

**[Syntax]**

Fsc□On <Control mode>, <Control characteristics >, <Offset cancel designation>
--

**[Terminology]**

<Control mode> Specifies the force sense control mode No. (See section [8.1.2.](#))  
Setting range: -1 - 9

**Table 11-2 Control mode setting items and corresponding values**

Setting Item	Control Mode					
	-1	0	1	2	-	9
Force sense control coordinate system	M_FsCod1	M_FsCod0	FSCOD01	FSCOD02	-	FSCOD09
Force control mode	P_FsMod1	P_FsMod0	FSFMD01	FSFMD02	-	FSFMD09
Stiffness coefficient	P_FsStf1	P_FsStf0	FSSTF01	FSSTF02	-	FSSTF09
Damping coefficient	P_FsDmp1	P_FsDmp0	FSDMP01	FSDMP02	-	FSDMP09
Force sensor bias value	P_FsBias1	P_FsBias0	FSBIAS01	FSBIAS02	-	FSBIAS09
Load center of gravity position	P_FsGrPos1	P_FsGrPos0	FSGRP01	FSGRP02	-	FSGRP09
Load mass	M_FsMass1	M_FsMass0	FSMASS01	FSMASS02	-	FSMASS09

<Control characteristics > Specifies the force sense control characteristics No. (See section [8.1.2.](#))  
Setting range: -1 - 9

**Table 11-3 Control characteristics setting items and corresponding values**

Setting Item	Control characteristics					
	-1	0	1	2	-	9
Force command value	P_FsFCd1	P_FsFCd0	FSFCMD01	FSFCMD02	-	FSFCMD09
Speed command value	P_FsSpd1	P_FsSpd0	FSSPD01	FSSPD02	-	FSSPD09
Mode switching judgment value	P_FsSwF1	P_FsSwF0	FSSWF01	FSSWF02	-	FSSWF09
Force sense control gain	P_FsGn1	P_FsGn0	FSFGN01	FSFGN02	-	FSFGN09
Force detection setting value	P_FsFLm1	P_FsFLm0	FSFLMT01	FSFLMT02	-	FSFLMT09

<Offset cancel designation> Specifies whether to cancel the force sensor data offset component.  
(zero point offset)  
Setting value: 0 (Do not cancel)/1 (Cancel)  
(For details, see section [8.1.3.](#))

**[Example]**

Refer to examples in section [11.9.](#)

[Description]

- (1) Enables the force sense control function using force sensor. (Default: Disabled)
- (2) The force sense control content is specified with the "control mode" and "control characteristics " condition Nos. set beforehand.
- (3) If the force sensor is not connected and this command is executed, error L3986 occurs.
- (4) This command cannot be executed when the force sense control function is enabled (error L3987 occurs.) If changing the "control mode" or "control characteristics ", execute the Fsc Off command to disable the force sense control function, and then execute the Fsc On command again. However, the "control characteristics " can be changed during operation using the FsGChg command or FsCTrg command.
- (5) "Control mode" and "control characteristics " 1 to 9 use setting values for each corresponding parameter. (Refer to Table 11-2 for details of setting items contained in control mode and control characteristics.)
- (6) If the "control mode" or "control characteristics " is 0 or -1, conditions set with dedicated status variables are used. The default status is the same setting as if "control mode" and "control characteristics " 1 is specified. (Refer to Table 11-2 for details of setting items contained in control mode and control characteristics.)
- (7) If the offset cancel designation is 1, force sensor data becomes 0 for all axes when this command is executed, and the sensor offset component is offset (zero point offset). No offset is made if the offset cancel designation is 0.
- (8) If the offset cancel designation is 1 and a value is set in the following data specified in the <control mode> (force sense calibration executed), the offset component cancel data is updated in sequential consideration of the load while the force sense control is turned on.
  - Force sensor bias value
  - Load center of gravity position
  - Load mass
- (9) If the offset cancel designation is 1, execute this command after the robot stops completely. If the command is executed immediately after the movement, the zero point offset may not be performed properly due to an inertial force.
- (10) The force sense control enabled/disabled status and "control mode"/"control characteristics" settings are common to both AUTOMATIC and MANUAL modes.
- (11) Even if an interpolation continuous command is specified with the Cnt command, the command is executed after waiting for the robot movement to be completed.
- (12) Force sense control is disabled by performing a program reset or executing an End command. (See Fig. 11-1.)
- (13) Force sense control processing functions only when the servo is ON. Even if force sense control is enabled, force sense control processing is not performed while the servo is OFF. If the servo is turned OFF while performing force sense control processing, processing is stopped. Force sense control processing is then resumed by turning the servo ON again. (See Fig. 11-1.)

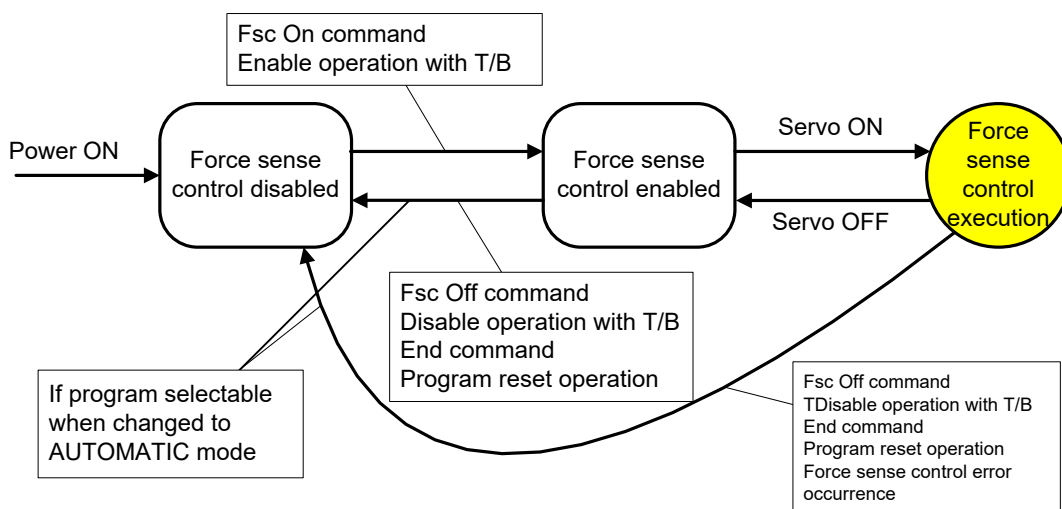

Fig. 11-1: Force sense control function status transition

- (14) When force sense control is not being performed, force sensor data checks using the force detection setting value are not performed.

(15) The force sense control function and functions listed in Table 11-4 cannot be used at the same time.

**Table 11-4 Behavior with simultaneous used with force sense control function**

Function	Behavior with Simultaneous Use	Error
Compliance control (Cmp command)	Priority is given to the function enabled first.	L3986
Collision detection (ColChk command)	Priority is given to the force sense control function. If force sense control function is enabled while collision detection is enabled, collision detection is disabled. If force sense control function is then disabled, collision detection returns to the status specified at that time.	L3986 *1
Tool/base coordinate system conversion (Base/Tool command, etc.)	Tool/base conversion data is not changed while force sense control is enabled.	L3986
Jrc command	The Jrc command cannot be executed while force sense control is enabled.	L3986
Continue function	The force sense control function is not compatible with the continue function.	-

\* 1: An error occurs if collision detection is enabled with the ColChk command during automatic operation and when the force sense control function is enabled.

(16) If positioning complete is executed with the Fine J command (joint)/Fine P command (linear) while force sense control is enabled, there may be times when the robot is unable to arrive at its target destination due to the external force acting on the force sensor, preventing positioning from being completed. If executing positioning complete, use the Fine command (pulse).

(17) If changing both the force sense control and tracking functions from an enabled status to disabled status when performing automatic operation, first execute the Trk Off command to disable the tracking function, and then disable force sense control with the Fsc Off command. If the Fsc Off command is executed first, an L2750 error occurs.

(18) Even if force sense control is enabled, a user defined area and free plane limit check are performed by referencing the position command. The force sense position command is not referenced.

---

## Fsc Off

### [Function]

Disables the force sense control function using force sensor.

### [Syntax]

Fsc□Off
---------

### [Example]

Refer to examples in section [11.9](#).

### [Description]

- (1) Disables the force sense control function using force sensor.
- (2) If the force sensor is not connected, no processing is performed when this command is executed.
- (3) Similarly, no processing is performed when this command is executed while the force sense control function is disabled.
- (4) The "position command" changes to the "force sense position command" when force sense control becomes disabled.

**FsGChg (Fs gain change)****[Function]**

Changes control characteristics for force sense control during operation.

**[Syntax]**

```
FsGChg <Change start time>, <Change time>, <Control characteristics group No. after change>
```

**[Terminology]**

- <Change start time> Specifies the position at which the control characteristics setting change is started. This is specified with an interrupt during the next interpolation command start point and end point.  
Setting range: 0 - 100 [%]
- <Change time> Specifies the time taken to change the control characteristics setting. The force detection setting value and mode switching judgment value change immediately, regardless of this specification.  
Setting range: 1 - 1000 [ms]
- <Control characteristics group No. after change> Specifies the control characteristics group No. applied after the change.  
Setting range: -1 to 9

**[Example]**

Refer to examples in section [11.9](#).

**[Description]**

- (1) Changes the force sense control function control characteristics from the current setting to the specified control characteristics.
- (2) After executing this command, when the command position reaches the specified change start position, the control characteristics change is started for the first interpolation command. (The force detection setting value changes immediately when this position is reached.)
- (3) The force sense control gain and force command are changed to the setting values specified with "Control characteristics " over the time set in <Change time>.

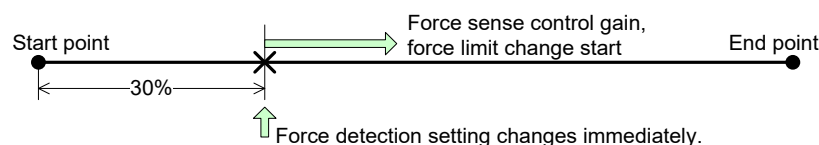

Example 1: If change start position is 30%

- (4) If the force sensor is not connected, no processing is performed when this command is executed.
- (5) This command cannot be executed when the force sense control gain and force command are being changed (when the change time has not elapsed). (Error L3987)
- (6) If the force sense control function is disabled without executing the interpolation command, this command will be disabled.
- (7) The "Control characteristics " change specification can only be executed during automatic operation. If operation is interrupted before starting the change and the mode key is switched from AUTOMATIC to MANUAL, change processing becomes invalid at that point.
- (8) When the force sense control gain and force command are being changed (when the change time has not elapsed), processing of these changes is continued until completion, even if the force sense control function is disabled.
- (9) After executing this command, the command specification also becomes invalid when the force sense control function is disabled, without executing the interpolation command.



FcCTrg (FsC trigger)

## [Function]

Sets force sense control characteristics switching with the Mo trigger.

## [Syntax]

```
FsCTrg <Trigger No.>, <Change time>, <Control characteristics group No. after change>
      [, <Timeout>, <Execution method> [, <Error specification>]]
```

## [Terminology]

- <Trigger No.> Specifies the Mo trigger No. used to change the control characteristics with a constant.  
Setting range: 1 - 3
- <Change time> Specifies the time taken to change the control characteristics.  
The force detection setting value and mode switching judgment value change immediately, regardless of this setting.  
Setting range: 1 – 1000 [ms]
- <Control characteristics group No. after change>  
Specifies the control characteristics group No. applied after the change.  
Setting range: -1 to 9
- <Timeout> Specifies the Mo trigger timeout monitoring time with a constant.  
Setting range: 0 – 60 [s]  
If omitted, timeout processing is not performed.
- <Execution method> Specifies the timeout monitoring execution method for this command with a constant.  
0: Proceeds to next program without waiting for Mo trigger ON.  
1: Does not proceed to next program until Mo trigger turns ON or timeout reached.
- <Error specification> Specifies whether an error occurs following a timeout.  
0: Error occurs.  
1: Error does not occur.  
An error occurs following a timeout if omitted.

## [Example]

```
1 Def MoTrg 3, (P_Fbc.Z < 100) 'Defines Mo trigger No.3.
2 Fsc On, 1, 1, 1 'Enables force sense control.
3 FcCTrg 3, 100, 2 'Enables Mo trigger No.3 and changes the control characteristics from 1 to 2 when the trigger turns ON.
4 Mvs P1
```

## [Description]

- (1) Sets force sense control characteristics switching with the Mo trigger.
- (2) By executing this command, the Mo trigger for the specified trigger No. is enabled, and the control characteristics is changed when the trigger turns ON. When the control characteristics change is complete, the change setting with this command will become unset.
- (3) If this command is executed when the Mo trigger is disabled, the Mo trigger for the specified trigger No. is enabled.
- (4) If the Mo trigger for the specified trigger No. is undefined, an error occurs when the program is run. (Error L.3770)
- (5) If an Mo trigger for a different No. than that specified for <Trigger No.> is currently enabled, the enabled trigger is disabled, and the Mo trigger specified for <Trigger No.> is enabled.
- (6) After starting the change, the control characteristics "force sense control gain" and "force specification value", and "speed command value" are changed to linear values toward the <Control characteristics group No. after change> control characteristics setting, over the time set in <Change time>. The "force detection setting value" and "mode switching judgment value" change immediately, regardless of this setting.
- (7) If a <Timeout> is specified, an error occurs after executing this command if the Mo trigger turns ON and

- control characteristics change is not completed within the specified time. (Error L.3987)
- (8) If program execution is interrupted, the timeout processing count up is also interrupted. If program execution is resumed, the timeout processing count up is also resumed.
  - (9) If program execution is interrupted, the timeout processing count up is also interrupted. If program execution is resumed, the timeout processing count up is also resumed.
  - (10) If a timeout occurs, the change setting with this command becomes unset, regardless of the error specification.
  - (11) After executing this command, if the force sense control function is disabled before the Mo trigger turns ON, the change setting with this command becomes unset.
  - (12) After executing this command, if the Mo trigger is disabled with the SetMoTrg command before the Mo trigger turns ON, the change setting with this command becomes unset.
  - (13) After executing this command, if operation is interrupted and the operation panel mode key is changed from "AUTOMATIC" to "MANUAL" before the Mo trigger turns ON, the change setting with this command becomes unset.
  - (14) Even if the force sense control function is disabled while processing the control characteristics change, processing continues until the change is complete. (Only the setting is changed. No control is performed.)
  - (15) An error occurs if this command is executed while processing the control characteristics change. (Error L.3987)
  - (16) An error occurs if this command is executed when the force sense control function is disabled. (Error L.3987)
  - (17) An error occurs if this command is executed when the control characteristics change is set with the FsGChg command. (Error L.3987)
  - (18) After executing this command, an error occurs when this command is executed again before the control characteristics changes. (Error L.3987)  
If changing the change setting, disable the Mo trigger with the SetMoTrg command, and then execute this function.
  - (19) After executing this command, an error occurs if the FsGChg command is executed before the control characteristics changes. (Error L.3987)
  - (20) If an End command is executed for the slot for which this command is executed, or if the program reset operation is performed, the change setting with this command becomes unset.
  - (21) This command setting is defined with respect to the robot. Unlike the Def Act command, if a sub-program is called with the CallP command, or if mechanical control rights are moved to another slot with the GetM or RelM commands, this command setting is continued.
  - (22) If the force sensor is not connected, no processing is performed even when this command is executed. No error in particular occurs.

## 11.2 Status Variables Relating to Force Sense Control Function

This section describes MELFA-BASIC V status variables relating to the force sense control function.

**Table 11-5 Force sense control status variables**

No.	Status Variable	Function Overview	
1	M_FsCod0, M_FsCod1	Specifies/references the force sense control coordinate system.	Control mode
2	P_FsMod0, P_FsMod1	Specifies/references the force sense control mode for each axis.	
3	P_FsStf0, P_FsStf1	Specifies/references the stiffness coefficient for each axis.	
4	P_FsDmp0, P_FsDmp1	Specifies/references the damping coefficient for each axis.	
5	P_FsFCd0, P_FsFCd1	Specifies/references the force command value for each axis.	Control characteristics
6	P_FsSpd0, P_FsSpd1	Specifies/references the speed command value for each axis.	
7	P_FsSwF0, P_FsSwF0	Specifies/references the mode switching judgment value for each axis.	
8	P_FsGn0, P_FsGn1	Specifies/references the force sense control gain for each axis.	
9	P_FsFLm0, P_FsFLm1	Specifies/references the force detection setting value for each axis.	

M\_FsCod0, M\_FsCod1

## [Function]

Specifies/references the force sense control coordinate system.

## [Syntax]

```
Example) M_FsCod0=<Numeric variable 1>
Example) <Numeric variable 2>=M_FsCod1
```

## [Terminology]

<Numeric variable 1> Specifies the force sense control coordinate system.

Setting	Mode
0	Coordinate system (Tool)
1	Coordinate system (XYZ)

<Numeric variable 2> Specifies the save destination for the read control coordinate information.

## [Example]

Refer to examples in section [11.9](#).

## [Description]

- (1) Specifies/references the coordinate system for which force control is performed contained in the condition group (control mode).
- (2) The specified value is used if the Fsc On command <control mode> is set to "-1" or "0".
- (3) Default status: The parameter FSCOD01 setting value is updated.
- (4) The value substituted for the status variable is retained until the power is turned OFF.
- (5) When force sense control is enabled with <control mode> = "0", it is not possible to write M\_FsCod0. (Error L3987 occurs.)
- (6) When force sense control is enabled with <control mode> = "-1", it is not possible to write M\_FsCod1. (Error L3987 occurs.)
- (7) When no force sensor is connected, the value is not applied even if it is written. Also if the setting value is read, always 0 is output.

P\_FsMod0, P\_FsMod1

## [Function]

Specifies/references the force sense control mode for each axis.

## [Syntax]

Example) P_FsMod0=<Position variable 1>
Example) <Position variable 2>=P_FsMod1

## [Terminology]

<Position variable 1> Specifies the force sense control mode for each axis.

Setting	Mode
0	Position control
1	Force control
2	Stiffness control
3	Limited stiffness control

<Position variable 2> Specifies the save destination for the read control coordinate information.

## [Example]

Refer to examples in section [11.9](#).

## [Description]

- (1) Specifies/references the force sense control mode for each axis contained in the condition group (control mode).
- (2) The specified value is used if the Fsc On command <control mode> is set to "-1" or "0".
- (3) Default status: The parameter FSFMD01 setting value is updated.
- (4) The value substituted for the status variable is retained until the power is turned OFF.
- (5) When force sense control is enabled with <control mode> = "0", it is not possible to write P\_FsMod0. (Error L3987 occurs.)
- (6) When force sense control is enabled with <control mode> = "-1", it is not possible to write P\_FsMod1. (Error L3987 occurs.)
- (7) When no force sensor is connected, the value is not applied even if it is written. Also if the setting value is read, always 0.0 is output for all elements.

P\_FsStf0, P\_FsStf1

## [Function]

Specifies/references the stiffness coefficient for force sense control (stiffness control).

## [Syntax]

Example) P\_FsStf0=<Position variable 1>  
 Example) <Position variable 2>=P\_FsStf1

## [Terminology]

<Position variable 1> Specifies the stiffness coefficient for force sense control (stiffness control).  
 (The L1- and L2-axis components do not use this variable.)

Component	Setting Range	Unit
X, Y, Z	0.0 - 1000.0	N/mm
A, B, C	0.0 - 1000.0	N·m/deg
L1, L2	0.0	-

<Position variable 2> Specifies the save destination for the read stiffness coefficient.

## [Example]

Refer to examples in section [11.9](#).

## [Description]

- (1) Specifies/references the stiffness coefficient for stiffness control contained in the condition group (control mode).
- (2) The specified value is used if the Fsc On command <control mode> is set to "-1" or "0".
- (3) Default status: The parameter FSSTF01 setting value is updated.
- (4) The value substituted for the status variable is retained until the power is turned OFF.
- (5) When force sense control is enabled with <control mode> ="0", it is not possible to write P\_FsStf0. (Error L3987 occurs.)
- (6) When force sense control is enabled with <control mode> ="-1", it is not possible to write P\_FsStf1. (Error L3987 occurs.)
- (7) When no force sensor is connected, the value is not applied even if it is written. Also if the setting value is read, always 0.0 is output for all elements.

P\_FsDmp0, P\_FsDmp1

## [Function]

Specifies/references the damping coefficient (responsiveness) for force sense control (stiffness control/force control).

## [Syntax]

Example) P\_FsDmp0=<Position variable 1>

Example) <Position variable 2>=P\_FsDmp1

## [Terminology]

<Position variable 1> Specifies the damping coefficient for force sense control.  
(The L1- and L2-axis components do not use this variable.)

Component	Setting Range	Unit
X, Y, Z	0.0 - 1.0	N/(mm/s)
A, B, C	0.0 - 1.0	N·m/(deg/s)
L1, L2	0.0	-

<Position variable 2> Specifies the save destination for the read damping coefficient.

## [Example]

Refer to examples in section [11.9](#).

## [Description]

- (1) Specifies/references the damping coefficient contained in the condition group (control mode).
- (2) The specified value is used if the Fsc On command <control mode> is set to "-1" or "0".
- (3) Default status: The parameter FSDMP01 setting value is updated.
- (4) The value substituted for the status variable is retained until the power is turned OFF.
- (5) When force sense control is enabled with <control mode> = "0", it is not possible to write P\_FsDmp0. (Error L3987 occurs.)
- (6) When force sense control is enabled with <control mode> = "-1", it is not possible to write P\_FsDmp1. (Error L3987 occurs.)
- (7) When no force sensor is connected, the value is not applied even if it is written. Also if the setting value is read, always 0.0 is output for all elements.

P\_FsFCd0, P\_FsFCd1

## [Function]

Specifies/references the force command value for force sense control (force control) or the limit value for the force control (limited stiffness control).

## [Syntax]

Example) P\_FsFCd0=<Position variable 1>

Example) <Position variable 2>=P\_FsFCd1

## [Terminology]

<Position variable 1> Specifies the force command value for force sense control (force control) or force sense control (limited stiffness control).

(In the force control, the L1- and L2-axis components do not use. In the limited stiffness control, set the resultant force to the L1-axis, and the limit value of the resultant moment to the L2-axis)

Component	Setting Range		Unit
	Force control	Limited stiffness control	
X, Y, Z	- force sense tolerance value to + force sense tolerance value	0.0 to + force sense tolerance value	N
A, B, C	- force sense tolerance value to + force sense tolerance value	0.0 to + force sense tolerance value	N · m
L1, L2	0.0	0.0 to + force sense tolerance value	Force control: idle Limited stiffness control: L1[N], L2[N · m]

<Position variable 2> Specifies the save destination for the read force command value/limit value.

## [Example]

Refer to examples in section [11.9](#).

## [Description]

- (1) Specifies/references the force command value (force control) or limit value (limited stiffness control) contained in the condition group (control characteristics).
- (2) The specified value is used if the Fsc On command <control characteristics > is set to "-1" or "0".
- (3) Default status: The parameter FSFCMD01 setting value is updated.
- (4) The value substituted for the status variable is retained until the power is turned OFF.
- (5) When force sense control is enabled with <control characteristics > = "0", it is not possible to write P\_FsFCd0. (Error L3987 occurs.)
- (6) When force sense control is enabled with <control characteristics > = "-1", it is not possible to write P\_FsFCd1. (Error L3987 occurs.)
- (7) When no force sensor is connected, the value is not applied even if it is written. Also if the setting value is read, always 0.0 is output for all elements.



P\_FsSpd0, P\_FsSpd1

## [Function]

Specifies/references the speed command value for force sense control (force control).

## [Syntax]

Example) P_FsSpd0=<Position variable 1>
Example) <Position variable 2>=P_FsSpd1

## [Terminology]

<Position variable 1> Specifies the speed command value for force sense control (force control).  
(The L1- and L2-axis components do not use this variable.)

Component	Setting Range	Unit
X, Y, Z	0.0 - 50.0	mm/s
A, B, C	0.0 - 50.0	deg/s
L1, L2	0.0	-

**Caution**

The speed restriction defined by the above setting range does not guarantee that the sensor will not malfunction as a result of collision on contact. When adjusting, move the robot at a low speed to begin with, and then increase the speed if required.

When doing so, check the force sensor data at the point of contact at the teaching pendant maximum value monitor, and set the speed to avoid too much force being applied.

<Position variable 2> Specifies the save destination for the read speed command value.

## [Example]

Refer to examples in section [11.9](#).

## [Description]

- (1) Specifies/references the speed command value contained in the condition group (control characteristics).
- (2) The specified value is used if the Fsc On command <control characteristics > is set to "-1" or "0".
- (3) Default status: The parameter FSSPD01 setting value is updated.
- (4) The value substituted for the status variable is retained until the power is turned OFF.
- (5) If the specified value is 0.0, speed priority mode does not function, and the robot moves in force priority mode at all times.
- (6) When force sense control is enabled with <control characteristics > = "0", it is not possible to write P\_FsSpd0. (Error L3987 occurs.)
- (7) When force sense control is enabled with <control characteristics > = "-1", it is not possible to write P\_FsSpd1. (Error L3987 occurs.)
- (8) If the force sensor is not connected, the value is not updated even if written. Furthermore, even if the setting value is read, 0.0 is always output for all elements.
- (9) If multiple axes are moved simultaneously in speed control mode, the actual robot movement speed is a synthesized speed for all axes.

P\_FsSwF0, P\_FsSwF1

## [Function]

Specifies/references the force priority mode/speed priority mode switching judgment value for the force sense function (force control).

## [Syntax]

Example) P\_FsSwF0=<Position variable 1>

Example) <Position variable 2>=P\_FsSwF0

## [Terminology]

<Position variable 1>

Specifies the force control mode/speed control mode switching judgment value for force sense control (force control).

(The L1- and L2-axis components do not use this variable.)

Component	Setting Range	Unit
X, Y, Z	-	N
A, B, C	-	N·m
L1, L2	0.0	-

<Position variable 2> Specifies the save destination for the read mode switching judgment value.

## [Example]

Refer to examples in section [11.9](#).

## [Description]

- (1) Specifies/references the mode switching judgment value contained in the condition group (control characteristics).
- (2) The specified value is used if the Fsc On command <control characteristics > is set to "-1" or "0".
- (3) Default status: The parameter FSSWF01 setting value is updated.
- (4) The value substituted for the status variable is retained until the power is turned OFF.
- (5) When force sense control is enabled with <control characteristics > = "0", it is not possible to write P\_FsSwF0. (Error L3987 occurs.)
- (6) If a value same as the force command is specified, the speed priority mode is disabled, and the robot always operates in the force priority mode.
- (7) When force sense control is enabled with <control characteristics > = "-1", it is not possible to write P\_FsSwF1. (Error L3987 occurs.)
- (8) If the force sensor is not connected, the value is not updated even if written. Furthermore, even if the setting value is read, 0.0 is always output for all elements.

P\_FsGn0, P\_FsGn1

## [Function]

Specifies/references the force sense control gain (responsiveness) for the force sense function.

## [Syntax]

Example) P\_FsGn0=<Position variable 1>

Example) <Position variable 2>=P\_FsGn1

## [Terminology]

<Position variable 1> Specifies the force sense control gain for force sense control.  
(The L1- and L2-axis components do not use this variable.)

Component	Setting Range	Unit
X, Y, Z	0.0 - 300.0	10 <sup>-3</sup> mm/N
A, B, C	0.0 - 300.0	10 <sup>-3</sup> deg/(N·m)
L1, L2	0.0	-

<Position variable 2> Specifies the save destination for the read force sense control gain.

## [Example]

Refer to examples in section [11.9](#).

## [Description]

- (1) Specifies/references the force sense control gain for each axis contained in the condition group (control characteristics).
- (2) The specified value is used if the Fsc On command <control characteristics > is set to "-1" or "0".
- (3) Default status: The parameter FSFGN01 setting value is updated.
- (4) The value substituted for the status variable is retained until the power is turned OFF.
- (5) When force sense control is enabled with <control characteristics > = "0", it is not possible to write P\_FsGn0. (Error L3987 occurs.)
- (6) When force sense control is enabled with <control characteristics > = "-1", it is not possible to write P\_FsGn1. (Error L3987 occurs.)
- (7) When no force sensor is connected, the value is not applied even if it is written. Also if the setting value is read, always 0.0 is output for all elements.

P\_FsFLm0, P\_FsFLm1

## [Function]

Specifies/references the force sensor force detection setting value for the force sense function.

## [Syntax]

Example) P_FsFLm0=<Position variable 1>
Example) <Position variable 2>=P_FsFLm1

## [Terminology]

<Position variable 1> Specifies the force sensor force detection setting value.  
(The L1- and L2-axis components do not use this variable.)

Component	Setting Range	Unit
X, Y, Z	0.0 - force sensor tolerance value	N
A, B, C	0.0 - force sensor tolerance value	N·m
L1, L2	0.0	-

<Position variable 2> Specifies the save destination for the read force detection setting value.

## [Example]

Refer to examples in section [11.9](#).

## [Description]

- (1) Specifies/references the force sensor force detection setting value contained in the condition group (control characteristics).
- (2) The specified value is used if the Fsc On command <control characteristics > is set to "-1" or "0".
- (3) Default status: The parameter FSFLMT01 setting value is updated.
- (4) The value substituted for the status variable is retained until the power is turned OFF.
- (5) When force sense control is enabled with <control characteristics > = "0", it is not possible to write P\_FsFLm0. (Error L3987 occurs.)
- (6) When force sense control is enabled with <control characteristics > = "-1", it is not possible to write P\_FsFLm1. (Error L3987 occurs.)
- (7) When no force sensor is connected, the value is not applied even if it is written. Also if the setting value is read, always 0.0 is output for all elements

## 11.3 Commands Relating to Force Sense Detection Function

This section describes MELFA-BASIC V commands relating to the force sense detection function (Mo trigger function).

Table 11-6 Mo trigger commands

No.	Command	Function Overview
1	Def MoTrg	Defines trigger conditions (Mo trigger) that reference position commands and the FB position, as well as force sensor data and so on.
2	SetMoTrg	Enables/disables trigger conditions (Mo trigger) that reference position commands and the FB position, as well as force sensor data and so on.

### Def MoTrg (Def Mo trigger)

#### [Function]

Defines trigger conditions (Mo trigger) that reference position commands and the FB position, as well as force sensor data and so on.

#### [Syntax]

```
Def □MoTrg <Trigger No.>, <Conditions>
```

#### [Terminology]

<Trigger No.> Specifies the defined Mo trigger No. with a constant.

Setting range: 1 - 3

<Conditions> Conditions under which the Mo trigger turns ON are described with the following syntax.

<Specification data> <Comparison operator> <Numerical data>

<Specification data> The following robot (system) status variables can be used.

- Status variables

All components of P\_Curr, P\_Fbc, J\_Curr, J\_Fbc, P\_FsCurP, P\_FsCurD, M\_FsRsltF, M\_FsRsltM

- Input signal M\_In

- Output signal M\_Out

<Numerical data> The following constants and variables can be used.

- Numeric constants, numeric variables, numeric array variables

- Position variable component data

- Joint variable component data

\* If a variable is set, the variable when executing this command is used for trigger condition judgment.

(Even if a variable is changed after executing this command, it is not updated to the judgment.)

\* Up to 4 types of <Conditions> can be combined and used with And and Or operators.

[Example: (<Condition A> And <Condition B>) Or (<Condition C> And <Condition D>)]

\* If rotational axis component data is specified for <Specification data>, the unit for the data used for conditions judgment will be radians. If using a numeric constant for <Numerical data>, use radian values, or append "DEG" such as in "45DEG", and then convert to radians.

## [Example]

- ```
1 Def MoTrg 1, ((P_Fbc.Z <= 100) Or (P_FsCurD.Z >= 10)) And (P_FsCurP.C < -45DEG)
  ' Defines the ON trigger as Mo trigger No.1 by satisfying the following conditions (1) and (2).
  ' (1) FB position Z-axis value is 100 mm or less, or Z-axis direction force sensor data is 10 N
    or greater.
  ' (2) Force sense command C-axis value is less than -45°.
```

## [Description]

- (1) Defines Mo trigger conditions with this command. The following data can be specified as trigger conditions.

| Data                    | Description                                                                                               |
|-------------------------|-----------------------------------------------------------------------------------------------------------|
| Each P_Curr component   | Robot current position (XYZ data)                                                                         |
| Each P_Fbc component    | Robot FB position (XYZ data)                                                                              |
| Each J_Curr component   | Robot current position (joint data)                                                                       |
| Each J_Fbc component    | Robot FB position (joint data)                                                                            |
| Each P_FsCurP component | Position command after offsetting with force control                                                      |
| Each P_FsCurD component | Force sensor data (values after updating offset cancel, converting Tool/XYZ coordinates)                  |
| M_FsRsltF               | Force sensor data resultant force (values after updating offset cancel, converting tool/XYZ coordinates)  |
| M_FsRsltM               | Force sensor data resultant moment (values after updating offset cancel, converting tool/XYZ coordinates) |
| M_In                    | Input signal ON/OFF status                                                                                |
| M_Out                   | Output signal ON/OFF status                                                                               |

- (2) The defined Mo trigger is enabled by executing the SetMoTrg command. The Mo trigger is not enabled simply by defining with this command.
- (3) If the Mo trigger for the trigger No. defined with this command is enabled, the trigger turns ON when the specified conditions are satisfied.
- (4) If multiple Def MoTrg commands are described for the same trigger No., the definition executed last is applied.
- (5) By executing this command for an enabled trigger No. Mo trigger, that Mo trigger becomes disabled, and changes to a new definition.
- (6) Up to 3 trigger Nos. can be defined for the Mo trigger. However, only one of these can be enabled. It is not possible to enable multiple Mo triggers.
- (7) Mo trigger conditions are defined for the robot. Unlike the Def Act command, if a sub-program is called with the CallP command, or if mechanical control rights are moved to another slot with the GetM or RelM commands, this command setting is continued.
- (8) Specify the same mechanical number for status variables used in <Conditions>. If mechanical Nos. are mixed, an error occurs when running the program. (Error L.3110)
- (9) If a non-existent mechanical number is specified for the status variable used in <Conditions>, an error occurs when running the program. (Error L.3870)
- (10) With robots that are not compatible with force sense control, it is not possible to specify P\_FsCurP, P\_FsCurD, M\_FsRsltF, or M\_FsRsltM for <Conditions>. An error occurs when running the program. (Error L.3986)

SetMoTrg (Set Mo trigger)

## [Function]

Enables/disables trigger conditions (Mo trigger) that reference position commands and the FB position, as well as force sensor data and so on.

## [Syntax]

|                        |
|------------------------|
| SetMoTrg <Trigger No.> |
|------------------------|

## [Terminology]

<Trigger No.> Specifies the trigger No. for the Mo trigger to be enabled with a constant.  
If 0 is specified, the Mo. Trigger is disabled.  
Setting range: 0 - 3

## [Example]

```
1 Def MoTrg 1, ((P_Fbc.Z <= 100) Or (P_FsCurD.Z >= 10)) And (P_FsCurP.C < -45DEG)
2 SetMoTrg 1          ' Enables Mo trigger No.1.
   :
   :
100 SetMoTrg 0        ' Disables the Mo trigger.
```

## [Description]

- (1) The Mo trigger is enabled/disabled with this command.
- (2) It is not possible to enable multiple Mo triggers simultaneously. If this command is executed consecutively, the Mo trigger enabled last is applied.
- (3) When performing force sense control characteristics change processing (FsCTrg command) using an Mo trigger, it is not possible to enable the Mo trigger with this command. An error occurs when running the program. (Error L.3987)  
The Mo trigger can be disabled.
- (4) If the specified Mo trigger No. has not been defined, an error occurs when running the program. (Error L3770)
- (5) If an End command is executed for the slot for which the trigger is enabled with this command, or if the program reset operation is performed, the Mo trigger will be disabled.
- (6) Mo trigger conditions are defined for the robot. Unlike the Def Act command, if a sub-program is called with the CallP command, or if mechanical control rights are moved to another slot with the GetM or ReIM commands, the Mo trigger conditions continue to apply.

## 11.4 Status Variables Relating Force Sense Detection Function

This section describes MELFA-BASIC V status variables relating to the force sense detection function.

**Table 11-7 Force sensor function related status variables**

| No. | Status Variable | Function Overview                                                                                                       | Class            |
|-----|-----------------|-------------------------------------------------------------------------------------------------------------------------|------------------|
| 1   | M_MoTrg         | Checks the Mo trigger enabled/disabled status and the trigger ON/OFF status while enabled.                              | Mo trigger       |
| 2   | M_FsLmtS        | Checks whether the force sensor data force detection setting value has been exceeded.                                   | Status display   |
| 3   | P_FsLmtR        | Checks the status of the current force sensor data with respect to the force sensor data force detection setting value. |                  |
| 4   | P_FsLmtX        | Checks/resets axes for which the force sensor data force detection setting value is exceeded.                           | Data latch       |
| 5   | P_FsLmtP        | Checks/resets the robot FB position when the force sensor data force detection setting value is exceeded.               |                  |
| 6   | P_FsLmtD        | Checks/resets the force sensor data when the force sensor data force detection setting value is exceeded.               |                  |
| 7   | P_FsMaxD        | Checks/resets the force sensor maximum data value during force sense control.                                           | Data referencing |
| 8   | P_FsCurD        | Checks the current force sensor data.                                                                                   |                  |
| 9   | P_FsCurP        | Checks the current position command offset with force sense control.                                                    |                  |
| 10  | M_FsRsltF       | Checks the current force sensor resultant force (Fx, Fy, Fz).                                                           |                  |
| 11  | M_FsRsltM       | Checks the current force sensor resultant moment (Fx, Fy, Fz).                                                          |                  |
| 12  | M_FsCSts        | Checks the force sense control enabled/disabled status.                                                                 |                  |



M MoTrg

## [Function]

Checks the Mo trigger enabled/disabled status and the trigger ON/OFF status while enabled.

## [Syntax]

Example) <Numerical variable>= M\_MoTrg (<Trigger No.>)

## [Terminology]

<Trigger No.> Specifies the Mo trigger No. being checked with a constant.  
Setting range: 1 - 3

<Numerical variable> Reads the Mo trigger defined/undefined status, enabled/disabled status, and trigger ON/OFF status while enabled, and specifies the save destination.

## [Example]

```
100 If M_MoTrg(2) = -2 Then      'If Mo trigger No.2 undefined:
101   Def MoTrg 2, P_Fbc.X > 500 ' Defines Mo trigger No.2,
102   SetMoTrg 2                ' Enables Mo trigger No.2.
103 EndIf
```

## [Description]

- (1) Checks the MO trigger defined/undefined status, enabled/disabled status, and trigger ON/OFF status while enabled.
- (2) If the Mo trigger is enabled and the defined conditions are satisfied, "+1" is returned, and if not satisfied, "0" is returned.
- (3) If the Mo trigger is disabled, "-1" is returned.
- (4) If the Mo trigger is undefined, "-2" is returned.
- (5) Immediately after turning ON the power, "-2" (undefined) is returned.

| Value | Details                  |                         |                       |
|-------|--------------------------|-------------------------|-----------------------|
|       | Defined/Undefined Status | Enabled/Disabled Status | Trigger ON/OFF Status |
| +1    | Defined                  | Enabled                 | ON                    |
| 0     | Defined                  | Enabled                 | OFF                   |
| -1    | Defined                  | Disabled                | ---                   |
| -2    | Undefined                | ---                     | ---                   |

## M\_FsLmtS

### [Function]

Checks whether the force sensor data force detection setting value has been exceeded.

### [Syntax]

|                                         |
|-----------------------------------------|
| Example) <Numerical variable>= M_FsLmtS |
|-----------------------------------------|

### [Terminology]

<Numerical variable>

Specifies the read numerical variable for determining whether the force detection setting value has been exceeded.

(1: Force detection setting value exceeded, 0: Force detection setting value not exceeded)

### [Example]

Refer to examples in section [11.9](#)

### [Description]

- (1) Displays whether the absolute value of the force sensor data has exceeded the force detection setting value. Displays 1 if exceeded, and 0 if not exceeded.
- (2) If there is more than one axis for which the force detection setting value has been exceeded, 1 is output.
- (3) The default status (when power ON) is 0. The value changes to 1 when the force detection setting value is exceeded while the force sense control function is enabled, and returns to 0 when no axes exceed the force detection setting value, or when force sense control is disabled.
- (4) The value is always 0 if the force sensor is not connected.
- (5) If movement is stopped when the force detection setting value is exceeded during automatic operation, it can be used as the interrupt processing condition to stop the movement.

P\_FsLmtR

## [Function]

Checks the status of the current force sensor data with respect to the force sensor data force detection setting value.

## [Syntax]

Example) <Position variable>= P\_FsLmtR

## [Terminology]

<Position variable> Specifies the substitute position variable.

## [Example]

Refer to examples in section [11.9](#).

## [Description]

- (1) Displays where the current force sensor data lies in the status shown in the following diagram with respect to the force detection setting value.

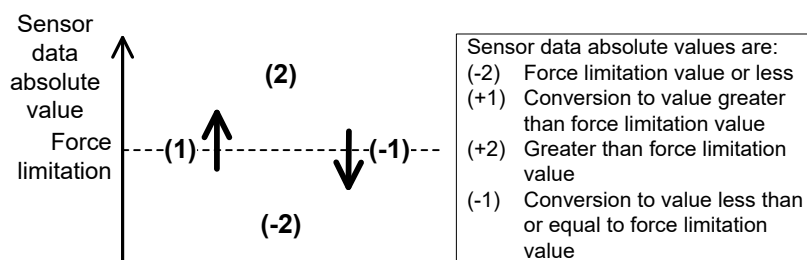

- (2) If force sense control is disabled, the value is 0 for all axes. When force sense control is enabled, the value is -2, -1, 1, or 2.
- (3) Axis correspondence is as follows: Fx=X-axis, Fy=Y-axis, Fz=Z-axis, Mx=A-axis, My=B-axis, Mz=C-axis.
- (4) The value is 0 for all axes if the force sensor is not connected.

## P\_FsLmtX

### [Function]

Checks/resets axes for which the force sensor data force detection setting value is exceeded.

### [Syntax]

|          |                               |
|----------|-------------------------------|
| Example) | <Position variable>= P_FsLmtX |
| Example) | P_FsLmtX =<Position variable> |

### [Terminology]

<Position variable> Specifies the substitute position variable.

### [Example]

Refer to examples in section [11.9](#).

### [Description]

- (1) Displays whether the force sensor data's absolute value has exceeded the force detection setting value. Displays 1 if exceeded, and 0 if not exceeded. If any axes exist for which the value has been exceeded even once, 1 is set for the corresponding axis element. 0 is set for axes for which the value has not been exceeded. The value is retained until reset.
- (2) Axis correspondence is as follows: Fx=X-axis, Fy=Y-axis, Fz=Z-axis, Mx=A-axis, My=B-axis, Mz=C-axis.
- (3) The default status (when power ON) is 0 for all axes. A value is set when the force detection setting value is exceeded while the force sense control function is enabled, and that value is then reset to 0 for all axes in the following cases.
  - When force sense control is enabled. (Execute the Fsc On command and enable force sense control with the teaching pendant.)
  - When the robot servo is turned from OFF to ON while force sense control is enabled.
  - When operation (4) below is performed.
- (4) By substituting a position variable (any position variable value is okay) for P\_FsLmtX, the value can be reset. By resetting, the P\_FsLmtP and P\_FsLmtD values are reset simultaneously.
- (5) The value is 0 for all axes if the force sensor is not connected.

## P\_FsLmtP

### [Function]

Checks/resets the robot FB position when the force sensor data force detection setting value is exceeded.

### [Syntax]

|          |                               |
|----------|-------------------------------|
| Example) | <Position variable>= P_FsLmtP |
| Example) | P_FsLmtP =<Position variable> |

### [Terminology]

<Position variable> Specifies the substitute position variable.

### [Example]

Refer to examples in section [11.9](#).

### [Description]

- (1) Checks robot position feedback when the force sensor data's absolute value exceeds the force detection setting value for the first time.
- (2) The default status (when power ON) is 0 for all axes. A value is set when the force detection setting value is exceeded while the force sense control function is enabled, and that value is then reset to 0 for all axes in the following cases.
  - When force sense control is enabled. (Execute the Fsc On command and enable force sense control with the teaching pendant.)
  - When the robot servo is turned from OFF to ON while force sense control is enabled.
  - When operation (3) below is performed.
- (3) By substituting a position variable (any position variable value is okay) for P\_FsLmtP, the value can be reset. By resetting, the P\_FsLmtX and P\_FsLmtD values are reset simultaneously.
- (4) The value is 0 for all axes if the force sensor is not connected.

## P\_FsLmtD

### [Function]

Checks/resets the force sensor data when the force sensor data force detection setting value is exceeded.

### [Syntax]

|          |                               |
|----------|-------------------------------|
| Example) | <Position variable>= P_FsLmtD |
| Example) | P_FsLmtD =<Position variable> |

### [Terminology]

<Position variable> Specifies the substitute position variable.

### [Example]

300 If P\_FsLmtX.X=1 Then P\_FsFLmt.X=P\_FsLmtD.X \* 0.8 'If X-direction sensor data exceeds the force detection setting value:  
'80% of the exceeded value is set as the new force detection setting value.

### [Description]

- (1) Checks force sensor data when the force sensor data's absolute value exceeds the force detection setting value for the first time.
- (2) The default status (when power ON) is 0 for all axes. A value is set when the force detection setting value is exceeded while the force sense control function is enabled, and that value is then reset to 0 for all axes in the following cases.
  - When force sense control is enabled. (Execute the Fsc On command and enable force sense control with the teaching pendant.)
  - When the robot servo is turned from OFF to ON while force sense control is enabled.
  - When operation (3) below is performed.
- (3) By substituting (any position variable value is okay) a position variable for P\_FsLmtD, the value can be reset. By resetting, the P\_FsLmtX and P\_FsLmtP values are reset simultaneously.
- (4) The value is 0 for all axes if the force sensor is not connected.

---

## P\_FsMaxD

### [Function]

Checks/resets the force sensor maximum data value during force sense control.

### [Syntax]

|                                        |
|----------------------------------------|
| Example) <Position variable>= P_FsMaxD |
| Example) P_FsMaxD =<Position variable> |

### [Terminology]

<Position variable> Specifies the substitute position variable.

### [Example]

1000 P1=P\_FsMaxD 'In P1, retains maximum force sensor data value up to this point.  
1010 P\_FsMaxD=P1 'Resets the maximum value.

### [Description]

- (1) Displays the force sensor data maximum value (maximum absolute value). (Maximum value of each axis is retained.)
- (2) The default status (when power OFF) is 0 for all axes. A value is set regardless of the force sense control function enabled/disabled status, and that value is retained when a value (any position variable value is okay) is substituted for P\_FsMaxD and offset cancel is performed, or until the maximum value is reset with the T/B.
- (3) The value is always 0 for all axes if the force sensor is not connected.

## P\_FsCurD

### [Function]

Checks the current force sensor data.

### [Syntax]

|                                        |
|----------------------------------------|
| Example) <Position variable>= P_FsCurD |
|----------------------------------------|

### [Terminology]

<Position variable> Specifies the substitute position variable.

### [Example]

100 Def Act 1, P\_FsCurD.Z > 10 GoTo \*INTR1, S

'If the Z-direction sensor data exceeds 10 N, an interrupt used to perform interrupt processing  
'\*INTR1 is defined.

200 M\_DOut(6000)=P\_FsCurD.X \* 100

'Multiplies the X-axis sensor data value by 100 (converts unit to 0.01 N).  
'Writes to CC-Link output register 6000.

### [Description]

- (1) Displays the current force sensor data.
- (2) Force sensor data converted to the tool coordinate direction is normally displayed; however, if force sense control is enabled in XYZ coordinate mode, force sensor data converted to the XYZ coordinate direction is displayed. Furthermore, the offset cancel (zero point offset) result is updated.
- (3) The current force sensor data can be checked even if the force sense control function is disabled.
- (4) The value is always 0 for all axes if the force sensor is not connected.



## P\_FsCurP

### [Function]

Checks the position (force sense position command) offset with force sense control.

(Force sense position command = Position command calculated with movement command, etc. + position offset with force sense control)

### [Syntax]

|                                        |
|----------------------------------------|
| Example) <Position variable>= P_FsCurP |
|----------------------------------------|

### [Terminology]

<Position variable> Specifies the substitute position variable.

### [Example]

2000 PD=P\_Curr – P\_FsCurP

'Outputs the difference between the position command and force sense position command.

2010 MD=Sqr(PD.X\*PD.X + PD.Y\*PD.Y + PD.Z\*PD.Z)

'Outputs the interpolation distance.

### [Description]

- (1) Checks the position offset with force sense control.
- (2) If the force sense control function is disabled, the same value as P\_Curr (position command) is output if the force sensor is not connected.

M\_FsRsltF

## [Function]

Checks the current force sensor resultant force (Fx, Fy, Fz).

## [Syntax]

|                                         |
|-----------------------------------------|
| Example) <Position variable>= M_FsRsltF |
|-----------------------------------------|

## [Terminology]

<Position variable> Specifies the substitute position variable.

## [Example]

1 \*L1 : If M\_FsRsltF < 10 Then GoTo \*L1

' If the force sensor resultant force is less than 10[N], repeat this step.

2 M\_Out(100) = 1

' If the force sensor resultant force is more than 10[N], turn the output signal 100 ON.

## [Description]

- (1) Displays the current resultant force of the force sensor. Resultant force F is determined as follows from the force component of the force sensor ( Fx, Fy, Fz ).

$$F = \sqrt{F_x^2 + F_y^2 + F_z^2}$$

- (2) The force sensor resultant force converted to the force in the tool coordinate direction is normally displayed; however, if force sense control is enabled in XYZ coordinate mode, the force sensor resultant force converted to the force in the XYZ coordinate direction is displayed. Furthermore, the offset cancel (zero point offset) result is updated.
- (3) Even if the force sense control function is invalid, it is possible to check the current resultant force of the force sensor.
- (4) When the force sensor is not connected, always returns 0.

M\_FsRsltM

## [Function]

Checks the current force sensor resultant moment (Fx, Fy, Fz).

## [Syntax]

|                                         |
|-----------------------------------------|
| Example) <Position variable>= M_FsRsltM |
|-----------------------------------------|

## [Terminology]

<Position variable> Specifies the substitute position variable.

## [Example]

1 \*L1 : If M\_FsRsltM < 1 Then GoTo \*L1

' If the force sensor resultant moment is less than 1[Nm], repeat this step.

2 M\_Out(100) = 1

' If the force sensor resultant moment is more than 1[Nm], turn the output signal 100 ON.

## [Description]

- (1) Displays the current resultant moment of the force sensor. Resultant moment M is determined as follows from the moment component of the force sensor ( Mx, My, Mz ).

$$M = \sqrt{M_x^2 + M_y^2 + M_z^2}$$

- (2) The force sensor resultant force converted to the force in the tool coordinate direction is normally displayed; however, if force sense control is enabled in XYZ coordinate mode, the force sensor resultant force converted to the force in the XYZ coordinate direction is displayed. Furthermore, the offset cancel (zero point offset) result is updated.
- (3) Even if the force sense control function is invalid, it is possible to check the current resultant moment of the force sensor.
- (4) When the force sensor is not connected, always returns 0.

## M\_FsCSts

[Function]

Checks the force sense control enabled/disabled status.

[Syntax]

|                                         |
|-----------------------------------------|
| Example) <Numerical variable>= M_FsCSts |
|-----------------------------------------|

[Terminology]

<Numerical variable> Specifies the substitute numerical variable.

(1: Force sense control enabled, 0: Force sense control disabled)

[Example]

2000 If M\_FsCSts=1 Then Fsc Off 'Disables force sense control if enabled.

[Description]

- (1) Checks the force sense control enabled/disabled status.
- (2) The value is 1 if force sense control is enabled, and 0 if disabled.
- (3) If force sense control is enabled, the status will be enabled (1) even if the servo is OFF.

## 11.5 Commands Relating to Force Sense Log Function

This section describes MELFA-BASIC V status variables relating to the log function.

Table 11-8: Log function commands

| No. | Command   | Function Overview                                                                         |
|-----|-----------|-------------------------------------------------------------------------------------------|
| 1   | FsLog On  | Starts force sensor data and position command, position FB, and current FB value logging. |
| 2   | FsLog Off | Ends force sensor data and position command, position FB, and current FB value logging.   |
| 3   | FsOutLog  | Reads logged data using FTP.                                                              |

### FsLog On

#### [Function]

Starts force sensor data and position command, position FB, and current FB value logging.

#### [Syntax]

```
FsLog□On
```

#### [Example]

Refer to examples in section [11.9](#).

#### [Description]

- (1) Collects the force sensor data and position command, position FB, and current FB value.
- (2) Data collection is ended 45s after the completion of this command, or when the FsLog Off command is executed.
- (3) This command cannot be executed again during data collection. (Error L3987 occurs.)
- (4) If the force sensor is not connected, no processing is performed when this command is executed.
- (5) If the log function is disabled (parameter FSLOGFN 1st element is 0), no processing is performed when this command is executed.

## FsLog Off

### [Function]

Ends force sensor data and position command, position FB, and current FB value logging.

### [Syntax]

|                          |
|--------------------------|
| FsLog□Off <Log File No.> |
|--------------------------|

### [Terminology]

<Log File No.>      Specifies the log file No. containing collected data.  
Setting range: 1 to 999999999

### [Example]

Refer to examples in section [11.9](#).

### [Description]

- (1) Ends collection of the force sensor data and position command, the position FB, and the current FB value, and creates a log file with the name specified for the log file No.
- (2) If the force sensor is not connected, no processing is performed when this command is executed.
- (3) No processing is performed if this command is executed without executing the FsLog On command.
- (4) If the log function is disabled (parameter FSLOGFN 1st element is 0), no processing is performed when this command is executed.
- (5) If 45s elapses after the execution of FsLog On command before executing this command, data collection stops automatically. However, log files are not created without executing this command.
- (6) Up to 2 log files can be stored in the controller. If the number of files stored exceeds 2, the file with oldest creation data is deleted.
- (7) If a log file No. the same as an existing log file is specified, the existing file is overwritten with the new file and saved.
- (8) If the log file size becomes larger than the file creation area during creation, data toward the end may be cut off.

## FsOutLog

### [Function]

Transfers logged data to the FTP server.

### [Syntax]

```
FsOutLog <Log File No.>
```

### [Terminology]

<<Log File No.> Specifies the No. of the log file from which collected data is to be read.  
Setting range: 1 to 999999999

### [Example]

Refer to examples in section [11.9](#).

### [Description]

- (1) Outputs CSV format log files created with the FsLog Off command to the FTP server.
- (2) The file name of the file output to the FTP server is "f<log file No.>.fsl".
- (3) Log files successfully transferred to the FTP server are deleted from the robot controller.  
If FTP transfer fails, error L3987 occurs and the log file is not deleted.
- (4) Error L3987 occurs if the log file for the specified No. does not exist.
- (5) If the force sensor is not connected, no processing is performed when this command is executed.
- (6) If the log function is disabled (parameter FSLOGFN 1st element is 0), or FTP is not used (parameter FSLOGFN 3rd element is 0), no processing is performed when this command is executed.
- (7) If the log file size becomes larger than the file creation area during creation, data toward the end may be cut off.
- (8) The maximum log file size is approximately 1.8 MB. Depending on the file size, FTP communication may take several tens of seconds.
- (9) If FTP communication fails, error L3987 (failed to output log file) occurs maximum of approximately 75 seconds after executing the FsOutLog command. In such a case, check the following again and reboot the robot controller.
  - Parameter (FTPID, FTPPASS, FTPSVRIP) settings relating to FTP communication
  - Condition of network between robot controller and FTP server
  - Settings and startup status at FTP server

## 11.6 Related Commands for Gravity Offset Cancel Function

MELFA-BASIC V commands relating to the gravity offset cancel function are described below.

**Table 11-9 Gravity offset cancel commands**

| No. | Command      | Function Overview                                                                                      |
|-----|--------------|--------------------------------------------------------------------------------------------------------|
| 1   | FsHndEst On  | Starts the process of the force sensor calibration.                                                    |
| 2   | FsHndEst Off | Estimates the force sensor calibration result and finishes the process.                                |
| 3   | FsGetDat     | Acquires the data (position and posture, force sensor data) required for the force sensor calibration. |

### FsHndEst On

#### [Function]

Starts the estimation process of the data (bias value, center of gravity position and mass of the load) required for the gravity offset cancel.

#### [Syntax]

```
FsHndEst□On <Control mode>
```

#### [Terminology]

<Control mode> Specifies the numerical value of status variables/parameters to store the estimated result. The argument value corresponds to that of the Fsc On command <control mode>. Setting range: -1 - 9

| Setting item               | Control mode |            |          |          |   |          |
|----------------------------|--------------|------------|----------|----------|---|----------|
|                            | -1           | 0          | 1        | 2        | - | 9        |
| Bias value                 | P_FsBias1    | P_FsBias0  | FSBIAS01 | FSBIAS02 | - | FSBIAS09 |
| Center of gravity position | P_FsGrPos1   | P_FsGrPos0 | FSGRP01  | FSGRP02  | - | FSGRP09  |
| Mass                       | M_FsMass1    | M_FsMass0  | FSMASS01 | FSMASS02 | - | FSMASS09 |

#### [Example]

```
1 FsHndEst On, 1           ' Starts the data acquisition for the gravity offset cancel.
2 For M1=1 To 9 Step 1    ' Repeats 9 times.
3 Mov PP(M1)              ' Robot moves to PP(M1) by joint interpolation.
4 Dly 1                   ' Waits for 1 second.
5 FsGetDat M1             'Stores the current robot posture and the force sensor data to
                           the FSEST#n parameter corresponding to the value of M1.
6 Next M1                 'Completes the repeat process.
7 FsHndEst Off            'Completes the data measurement for the gravity offset
                           cancel.
```

#### [Description]

- (1) Starts the estimation process of the bias value required for the gravity offset cancel and the center of gravity position and mass of the load installed to the force sensor.
- (2) If this command is executed without the force sensor, the process is not executed.
- (3) If this command is executed continuously, the <control mode> specified with the command executed last is enabled.



## FsHndEst Off

### [Function]

Estimates the data (bias value, center of gravity position and mass of the load) required for the gravity offset cancel and finishes the process.

### [Syntax]

|              |
|--------------|
| FsHndEst□Off |
|--------------|

### [Example]

|                        |                                                                                                                        |
|------------------------|------------------------------------------------------------------------------------------------------------------------|
| 1 FsHndEst On, 1       | ' Starts the data acquisition for the gravity offset cancel.                                                           |
| 2 For M1=1 To 9 Step 1 | ' Repeats 9 times.                                                                                                     |
| 3 Mov PP(M1)           | ' Robot moves to PP(M1) by joint interpolation.                                                                        |
| 4 Dly 1                | ' Waits for 1 second.                                                                                                  |
| 5 FsGetDat M1          | 'Stores the current robot posture and the force sensor data to the FSEST#n parameter corresponding to the value of M1. |
| 6 Next M1              | 'Completes the repeat process.                                                                                         |
| 7 FsHndEst Off         | 'Completes the data measurement for the gravity offset cancel.                                                         |

### [Description]

- (1) Estimates the bias value required for the gravity offset cancel and the center of gravity position and mass of the load installed to the force sensor, and finishes the process.
- (2) Executing this command starts the estimation process of the load using the data stored in the parameters from "FSEST01" to "FSEST09".
- (3) The result estimated by this command is stored in the status variable/parameter corresponding to the <control mode> specified in the FsHndEst On command.
- (4) If this command is executed when the FsHndEst On command is not executed, the process is not executed.
- (5) The estimated result is retained until the power supply is restarted or another FsHndEst Off command is executed.
- (6) If this command is executed without the force sensor, the process is not executed.
- (7) If this command is executed while the force sense control using the <control mode> specified in the FsHndEst On command is enabled, an error L3987 occurs.
- (8) When the invalid posture data is included in the parameters from "FSEST01" to "FSEST09", an error L3987 occurs. For the posture data used by this command, see section 12 .
- (9) If the estimation result is abnormal, an error L3987 occurs.

**FsGetDat****[Function]**

Acquires the data (robot's position posture and force sensor data) required for the force sense calibration and stores it in a parameter.

**[Syntax]**

```
FsGetDat□<Data No.>
```

**[Terminology]**

<Data No.>            Specifies the parameter number to store the data acquired.  
                           The argument value corresponding to the number of the parameter from "FSEST01" to "FSEST09".  
                           Setting range: 1 - 9

**[Example]**

|                        |                                                                                                                        |
|------------------------|------------------------------------------------------------------------------------------------------------------------|
| 1 FsHndEst On, 1       | ' Starts the data acquisition for the gravity offset cancel.                                                           |
| 2 For M1=1 To 9 Step 1 | ' Repeats 9 times.                                                                                                     |
| 3 Mov PP(M1)           | ' Robot moves to PP(M1) by joint interpolation.                                                                        |
| 4 Dly 1                | ' Waits for 1 second.                                                                                                  |
| 5 FsGetDat M1          | 'Stores the current robot posture and the force sensor data to the FSEST#n parameter corresponding to the value of M1. |
| 6 Next M1              | 'Completes the repeat process.                                                                                         |
| 7 FsHndEst Off         | 'Completes the data measurement for the gravity offset cancel.                                                         |

**[Description]**

- (1) Stores the robot's position posture and the force sensor data at the time of this command execution in the parameter specified in the <Data No.>.
- (2) If this command is executed without the force sensor, the process is not executed.
- (3) If this command is executed when the FsHndEst On command is not executed, an error L3987 occurs.

## 11.7 Related Status Variables for Gravity Offset Cancel Function

MELFA-BASIC V status variables relating to the gravity offset cancel function are described below.

**Table 11-10 Gravity offset cancel status variables**

| No. | Status variables          | Function Overview                                                                            |              |
|-----|---------------------------|----------------------------------------------------------------------------------------------|--------------|
| 1   | P_FsBias0,<br>P_FsBias1   | Specifies/references the bias value used for the gravity offset cancel.                      | Control mode |
| 2   | P_FsGrPos0,<br>P_FsGrPos1 | Specifies/references the load center of gravity position used for the gravity offset cancel. |              |
| 3   | M_FsMass0,<br>M_FsMass1   | Specifies/references the load mass used for the gravity offset cancel.                       |              |

P\_FsBias0, P\_FsBias1

## [Function]

Specifies/references the bias value used for the gravity offset cancel.

## [Syntax]

|                                                                                        |
|----------------------------------------------------------------------------------------|
| Example) P_FsBias0= <Position variable 1><br>Example) <Position variable 2>= P_FsBias1 |
|----------------------------------------------------------------------------------------|

## [Terminology]

- < Position variable 1> Specifies the bias value used for the gravity offset cancel.
- < Position variable 2> Specifies the save destination for the read bias value.

## [Example]

Refer to examples in section [11.9](#).

## [Description]

- (1) Specifies/references the force sensor bias value contained in the condition group (control mode).
- (2) The specified value is used if the Fsc On command <control mode> is set to "-1" or "0".
- (3) Default status: The parameter "FSBIAS01" setting value is updated.
- (4) The value substituted for the status variable is retained until the power is turned OFF.
- (5) The estimated result is substituted when the FsHndEst Off command is executed after the FsHndEst On command <control mode> is set to "-1" or "0".
- (6) When the force sense control is enabled with <control mode> = "0", it is not possible to write P\_FsBias0. (An error L3987 occurs.)
- (7) When the force sense control is enabled with <control mode> = "-1", it is not possible to write P\_FsBias1. (An error L3987 occurs.)
- (8) When no force sensor is connected, the value is not applied even if it is written. Also, if the setting value is read, always 0.0 is output for all elements.

P\_FsGrPos0, P\_FsGrPos1

## [Function]

Specifies/references the load center of gravity position used for the gravity offset cancel.

## [Syntax]

Example) P\_FsGrPos0= <Position variable 1>

Example) <Position variable 2>= P\_FsGrPos1

## [Terminology]

< Position variable 1> Specifies the load center of gravity position used for the gravity offset cancel.

< Position variable 2> Specifies the save destination for the read load center of gravity position.

## [Example]

Refer to examples in section [11.9](#) .

## [Description]

- (1) Specifies/references the center of the gravity position of the load contained in the condition group (control mode).
- (2) The specified value is used if the Fsc On command <control mode> is set to "-1" or "0".
- (3) Default status: The parameter "FSBIAS01" setting value is updated.
- (4) The value substituted for the status variable is retained until the power is turned OFF.
- (5) The estimated result is substituted when the FsHndEst Off command is executed after the FsHndEst On command <control mode> is set to "-1" or "0".
- (6) When the force sense control is enabled with <control mode> = "0", it is not possible to write P\_FsBias0. (An error L3987 occurs.)
- (7) When the force sense control is enabled with <control mode> = "-1", it is not possible to write P\_FsBias1. (An error L3987 occurs.)
- (8) When no force sensor is connected, the value is not applied even if it is written. Also, if the setting value is read, always 0.0 is output for all elements.

*M FsMass0, < FsMass1*

## [Function]

Specifies/references the load mass used for the gravity offset cancel.

## [Syntax]

|                                                                                       |
|---------------------------------------------------------------------------------------|
| Example) M_FsMass0= <Numeric variable 1><br>Example) < Numeric variable 2>= M_FsMass1 |
|---------------------------------------------------------------------------------------|

## [Terminology]

- < Position variable 1> Specifies the load mass used for the gravity offset cancel.
- < Position variable 2> Specifies the save destination for the read load mass.

## [Example]

Refer to examples in section [11.9](#).

## [Description]

- (1) Specifies/references the mass of the load contained in the condition group (control mode).
- (2) The specified value is used if the Fsc On command <control mode> is set to "-1" or "0".
- (3) Default status: The parameter "FSBIAS01" setting value is updated.
- (4) The value substituted for the status variable is retained until the power is turned OFF.
- (5) The estimated result is substituted when the FsHndEst Off command is executed after the FsHndEst On command <control mode> is set to "-1" or "0".
- (6) When the force sense control is enabled with <control mode> = "0", it is not possible to write P\_FsBias0. (An error L3987 occurs.)
- (7) When the force sense control is enabled with <control mode> = "-1", it is not possible to write P\_FsBias1. (An error L3987 occurs.)
- (8) When no force sensor is connected, the value is not applied even if it is written. Also, if the setting value is read, always 0.0 is output for all elements.

## 11.8 Other Related Commands

### Def Act

#### [Function]

Defines the interrupt conditions and processing for interrupt processing. Interrupts are used when input signals and so on are monitored while running programs to prioritize certain processing when the specified conditions are reached

\* "F" (force sense stop) has been added to the argument <Type> for force sense control.

#### [Syntax]

```
Def□Act <Priority No.>, <Format>, <Processing> [, <Type>]
```

#### [Terminology]

|                |                                                                                                                                                                                                                                                                                                                                                                                                                                                                                                                                                                                                                                                                                                                                                                                                                                                |
|----------------|------------------------------------------------------------------------------------------------------------------------------------------------------------------------------------------------------------------------------------------------------------------------------------------------------------------------------------------------------------------------------------------------------------------------------------------------------------------------------------------------------------------------------------------------------------------------------------------------------------------------------------------------------------------------------------------------------------------------------------------------------------------------------------------------------------------------------------------------|
| <Priority No.> | This is the interrupt priority No. and sets Nos. 1 to 8 with a constant.                                                                                                                                                                                                                                                                                                                                                                                                                                                                                                                                                                                                                                                                                                                                                                       |
| <Format>       | This function is described with the following formats as the interrupt conditions.<br><Numerical data> <Comparison operator> <Numerical data> or,<br><Numerical data> <Logic operator> <Numerical data><br>* <Numerical data> refers to the following:<br><Numeric constant>   <Numeric variable>   <Numeric array constant>   <Component data>                                                                                                                                                                                                                                                                                                                                                                                                                                                                                                |
| <Processing>   | Describes the GoTo or GoSub statement required for processing when an interrupt occurs.                                                                                                                                                                                                                                                                                                                                                                                                                                                                                                                                                                                                                                                                                                                                                        |
| <Type>         | Omission: Stop type 1<br>Stops at the stop position assuming an external override of 100%.<br>It takes longer to stop if the external override is small, and so the robot always stops at the same position.<br>S: Stop type 2<br>Not dependent on the external override, and the robot decelerates to a stop over the minimum time and distance.<br>L: Execution complete stop<br>Performs interrupt processing after the robot has moved (1 line is completed during execution) to its target position.<br>F: Force sense stop<br>Not dependent on the external override, and the robot decelerates to a stop over the minimum time and distance.<br>If force sense control is enabled, the robot stops immediately when the robot movement speed linear component is 50 [mm/s] or less, and the rotational component is 50 [deg/s] or less. |

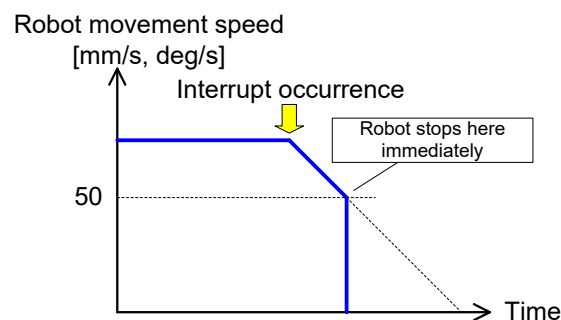

If force sense control is disabled, the robot decelerates to a stop in the same manner as that for Stop type 2 (S).

- \* Additional axes decelerate to a stop in the same manner as that for Stop type 2 (S), regardless of whether force sense control is enabled or disabled.
- \* If stopped with a Force sense stop (F), force sense control is disabled (including servo OFF), or position offset with force sense control is fixed at the stopped status until the interrupt is prohibited with "Act <Priority No.>=0".
- \* Use upper case alphabet characters for the <Type>. If lower case alphabet characters are used, an error occurs when registering. (Error L.4220)

## [Example]

```

1 Def Act 1,M_In(17)=1 GoSub *L100      ' When the input signal for general purpose input signal No. 17
  ' turns ON,
  ' this defines that the *L100 (step No. 10) sub-routine
  ' is called.
2 Def Act 2,MFG1 And MFG2 GoTo *L200   ' If logical products MFG1 and MFG2 become true,
  ' this defines a jump to *L200 (step No. 20).
3 Def Act 3,M_Timer(1)>10500 GoSub *LBL ' Jumps to *LBL (step No. 30) sub-routine after 10.5 seconds
  ' has elapsed.
:
10 *L100:M_Timer(1)=0                  ' Sets the timer to zero.
11 Act 3=1                              ' Enables Act 3.
12 Return 0
:
20 *L200:Mov P_Safe
21 End
:
30 *LBL
31 M_Timer(1)=0                        ' Returns the timer to zero.
32 Act 3=0                              ' Disables Act 3.
32 Return 0

```

## [Description]

- (10) Describes a Return command at the end of the jump destination processing called with the interrupt.
- (11) If returned to the next step from interrupt processing with Return 1, prohibit interrupts in the interrupt processing. If interrupts are not prohibited and interrupt conditions are left established, interrupt processing is performed again before returning to the next step, and therefore there are times when steps are skipped without being executed.
- (12) The interrupt priority sequence is fixed with the <Priority No.>, and the priority rises in the order 1 to 8 as the number increases.
- (13) Up to 8 interrupts can be set simultaneously, and are distinguished by <Priority No.>.
- (14) Only a simple <Logic operator> or <Comparison operator> can be used for <Format>. Parentheses (operator) cannot be used either.
- (15) If a Def Act command for the same priority No. is described, the latter defined command is enabled.
- (16) The Def Act command is used only to define interrupts, and therefore interrupt permission/prohibition should be specified with the Act command.
- (17) Priority for communication interrupts (Com) is even higher than for interrupts defined with the Def Act command.
- (18) The Def Act command is only valid within the defined program. If using interrupt processing in programs (sub-programs) called with the CallP command (call between programs), it is necessary to redefine processing at the sub-program.
- (19) If an interrupt occurs when a GoTo command is specified in <Processing> with the Def Act command, interrupts being processed while executing subsequent programs are left as is, and only interrupts with high priority are received. Processing of interrupts with the GoTo command is cancelled by executing the End command.



- 
- (20) It is not possible to describe a condition format combined with a log operator such as in (M1 And &H001) = 1.
- (21) If an interrupt is entered while performing perfect circle interpolation or circular interpolation (Mvc, Mvr, Mvr2, Mvr3) and control is returned to the original step with Return 0, the robot returns to the perfect circle or circular interpolation start point before once again performing circular or arc interpolation.
- (22) If an interrupt is entered while performing arch interpolation and control is returned to the original step with Return 0, the robot performs arch interpolation from the position at that time.

[Related commands]

Act



## Caution

Set the interrupt stop type correctly based on the application.

If wishing to stop the robot with an interrupt over the minimum time and distance when executing a movement command, specify "S" for the Stop type.

Conceptual drawings of each stop type for the execution program when interrupt conditions are established during robot movement are shown below.

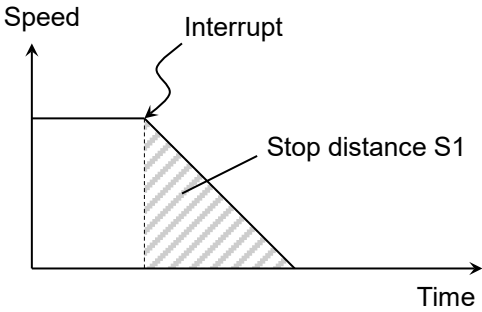
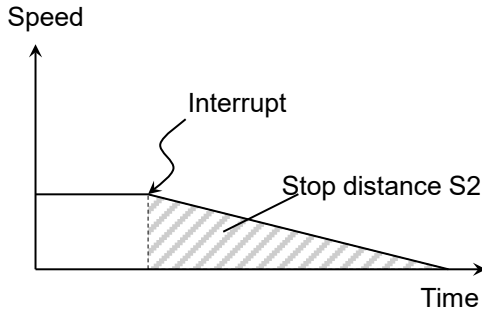
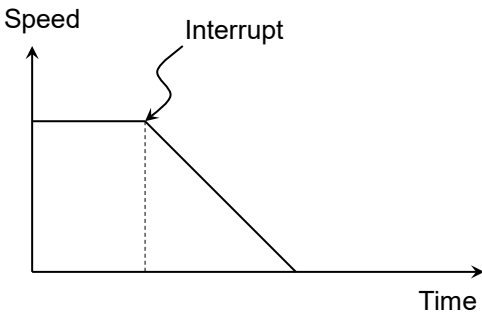
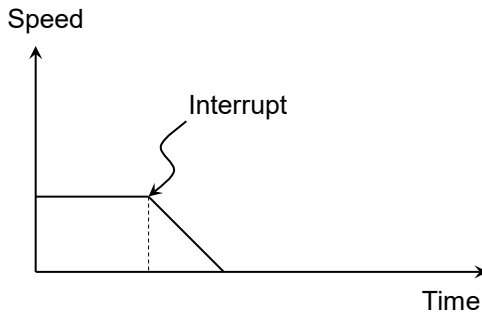
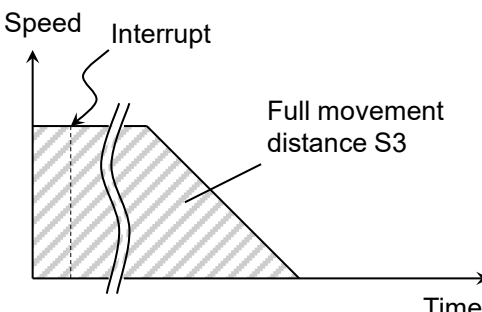
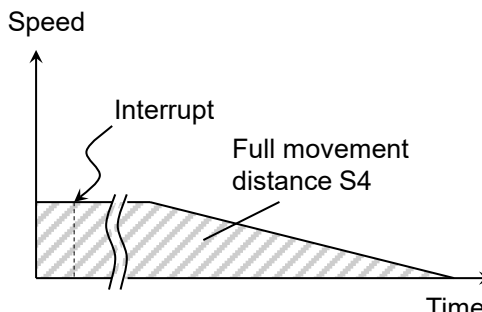
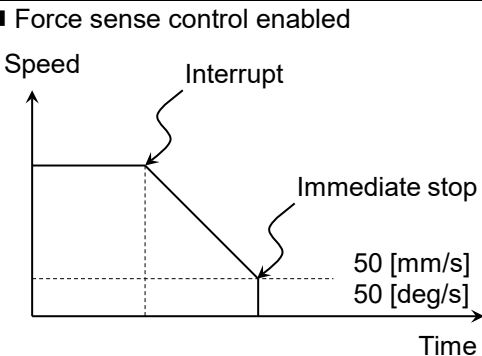
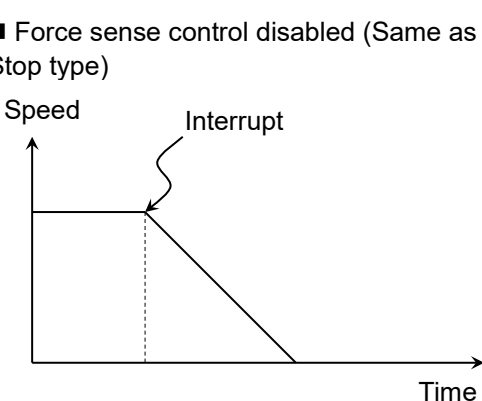
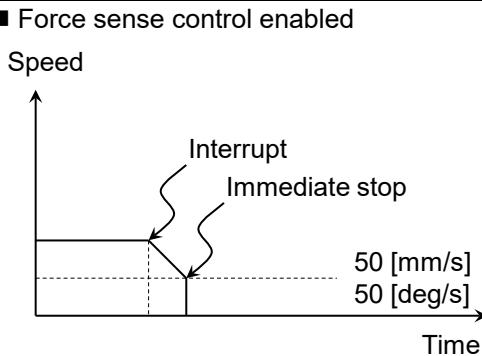
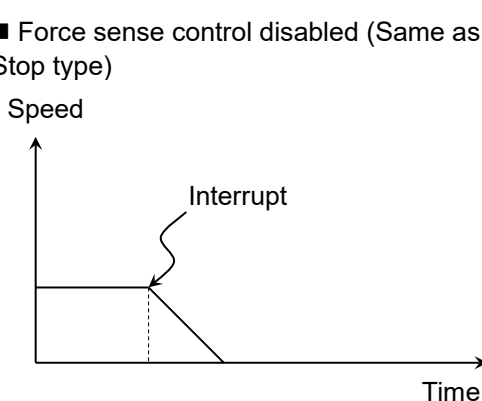
| Stop Type                                 | External Override 100% (Max. Speed)                                                                                                                                                                                                                                    | External Override 50%                                                                                                                                                                                                                                                    |
|-------------------------------------------|------------------------------------------------------------------------------------------------------------------------------------------------------------------------------------------------------------------------------------------------------------------------|--------------------------------------------------------------------------------------------------------------------------------------------------------------------------------------------------------------------------------------------------------------------------|
| Stop type 1<br>(Omission)<br>S1 = S2      |                                                                                                                                                                                       |                                                                                                                                                                                        |
| Stop type 2<br>(S)                        |                                                                                                                                                                                       |                                                                                                                                                                                        |
| Execution complete stop<br>(L)<br>S3 = S4 |                                                                                                                                                                                      |                                                                                                                                                                                       |
| Force sense stop<br>(F)                   | <p>■ Force sense control enabled</p>  <p>■ Force sense control disabled (Same as Stop type)</p>  | <p>■ Force sense control enabled</p>  <p>■ Force sense control disabled (Same as Stop type)</p>  |

## 11.9 Examples

Several force sense control program examples are shown below.

### ■ Example 1 (Sample Program FB01.prg)

The robot searches for the target object while moving in the Y-axis direction. When the object is found, the robot moves in the X-axis direction while applying a constant force in the target object Y-direction.

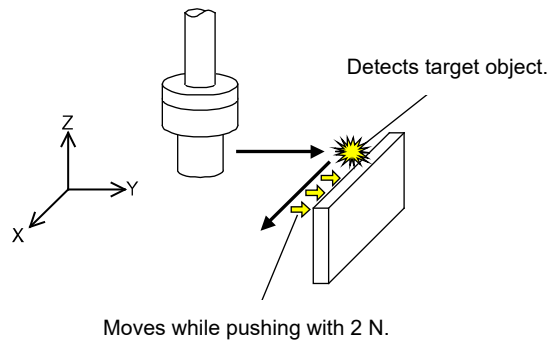

'Control mode ( 0 ) setting

|                                                     |                                                                          |
|-----------------------------------------------------|--------------------------------------------------------------------------|
| P_FsStf0=(+0.00,+0.01,+0.00,+0.00,+0.00,+0.00)(0,0) | 'Stiffness coefficient (Specifies Y-axis component as 0.01 [N/mm])       |
| P_FsDmp0=(+0.00,+0.00,+0.00,+0.00,+0.00,+0.00)(0,0) | 'Damping coefficient (no specification)                                  |
| P_FsMod0=(+0.00,+1.00,+0.00,+0.00,+0.00,+0.00)(0,0) | 'Force sense control type (Specifies force control in Y-axis direction.) |
| M_FsCod0=1                                          | 'Force sense coordinate system (Specifies XYZ coordinate system.)        |

'Control characteristics ( 0 ) setting

|                                                       |                                                                         |
|-------------------------------------------------------|-------------------------------------------------------------------------|
| P_FsGn0=(+0.00,+1.00,+0.00,+0.00,+0.00,+0.00)(0,0)    | 'Gain (Specifies Y-direction as 1.0 [ $10^{-3}$ mm/N].)                 |
| P_FsFLm0=(+20.00,+0.50,+20.00,+5.00,+5.00,+5.00)(0,0) | 'Force detection setting value (Specifies Y-axis direction as 0.5 [N].) |
| P_FsFCd0=(+0.00,+2.00,+0.00,+0.00,+0.00,+0.00)(0,0)   | 'Force control (Specifies Y-axis direction as 2.0 [N].)                 |

Def Act 1,M\_FsLmtS=1 GoTo \*XMOV,S 'Defines so that interrupt processing performed if force detection setting value exceeded.

FsLog On 'Starts collecting force sense log.

Fsc On,0,0,1 'Enables force sense control with control mode=0, control characteristics =0, and offset cancel enabled.

P1=P\_Curr

P1.Y=P1.Y+200

Spd 5

Act 1=1

Mvs P1 'Performs interrupt processing if contact with the target object is made during movement.

Fsc Off 'Disables force sense control.

FsLog Off,7 'Ends force sense log collection and creates log file No.7.

Act 1=0

End

'Interrupt processing

\*XMOV

P2=P\_FsCurPr

P2.X=P2.X+100 'Sets position +100 mm in X-axis direction from current position as target position.

FsGChg 5,100,2 'Changes the gain to the control characteristics 2 (parameter) setting value over 100 ms from the interpolation progress rate 5% position.

Mvs P2 'Moves in the X-axis direction while applying 2.0 [N] of force in the Y-axis direction.

Fsc Off 'Disables force sense control.

FsLog Off,7 'Ends force sense log collection and creates log file No.7.

FsOutLog 7 'Transfers log file No.7 to the computer by FTP.

End

### ■ Example 2 (Sample Program FB02.prg)

Performs the insertion movement in the Z-axis direction with the X/Y-direction softened. An error occurs and movement is interrupted if a force greater than the specified value is applied when inserting.

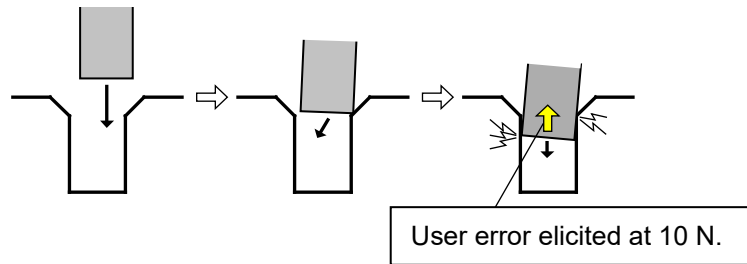

```

'Control mode ( 0 ) setting
P_FsStf0=(+0.01,+0.01,+0.00,+0.00,+0.00,+0.00)(0,0)      'Stiffness coefficient (Specifies X/Y-axis component as 0.01 [N/mm].)
P_FsDmp0=(+0.00,+0.00,+0.00,+0.00,+0.00,+0.00)(0,0)    'Damping coefficient (no specification)
P_FsMod0=(+2.00,+2.00,+0.00,+0.00,+0.00,+0.00)(0,0)    'Force sense control type (Specifies stiffness control in X/Y-axis direction.)
M_FsCod0=0  'Force sense coordinate system (Specifies tool coordinate system.)
'

'Control characteristics ( 0 ) setting
P_FsGn0=(+80.00,+80.00,+0.00,+0.00,+0.00,+0.00)(0,0)   'Gain (Specifies X/Y-axis direction as X,Y 80 [10-3 mm/N].)
P_FsFLm0=(+20.00,+20.00,+10.00,+5.00,+5.00,+5.00)(0,0) 'Force detection setting value (Specifies Z-axis direction as 10 [N].)
P_FsFCd0=(+0.00,+0.00,+0.00,+0.00,+0.00,+0.00)(0,0)   'Force control (no specification)
'

Def Act 1,P_FsLmtX.Z=1 GoTo *ESCP,S                    ' Defines so that interrupt processing performed if the force detection setting value is
exceeded in Z-direction.

Mov P1  'Moves to insertion start position.
'

FsLog On   'Starts collecting force sense log.
Fsc On,0,0,1   'Enables force sense control with control mode=0, control characteristics =0, and offset cancel enabled.
Spd 5
Act 1=1
Mvs P2   'Performs the insertion movement in the Z-axis direction and performs interrupt processing if the force detection setting
'value is exceeded.

Fsc Off  'Disables force sense control.
FsLog Off,1   'Ends force sense log collection and creates log file No.1.
Act 1=0
End
'

'Interrupt processing
*ESCP
Fsc Off  'Disables force sense control.
Spd 50
Mvs P1   'Retreats to insertion start position.
FsLog Off,1   'Ends force sense log collection and creates log file No.1.
FsOutLog 1   'Transfers log file No.7 to the computer by FTP.
Error 9100   Elicits error L9100.
End

```

### ■ Example 3 (Sample Program FB03.prg)

Searches for open holes on the XY plane. If a hole is found, the XY coordinates for the holes center position are calculated.

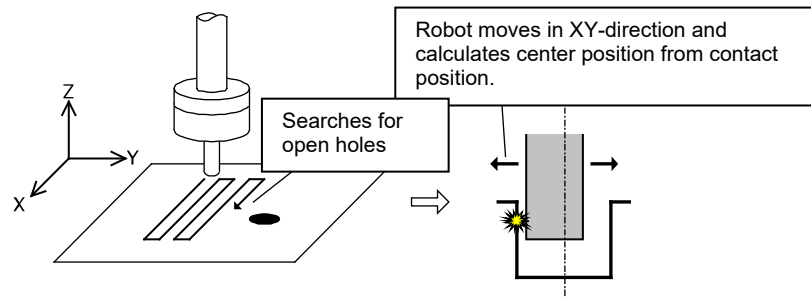

'Control mode ( 0 ) setting

P\_FsStf0=(+0.00,+0.00,+1.00,+0.00,+0.00,+0.00)(0,0)

'Stiffness coefficient (Specifies Z-axis component as 1 [N/mm].)

P\_FsDmp0=(+0.00,+0.00,+0.00,+0.00,+0.00,+0.00)(0,0)

'Damping coefficient (no specification)

P\_FsMod0=(+0.00,+0.00,+2.00,+0.00,+0.00,+0.00)(0,0)

'Force sense control type (Specifies stiffness control in Z-axis direction.)

M\_FsCod0=1

'Force sense coordinate system (Specifies XYZ coordinate system.)

,

'Control characteristics ( 0 ) setting

P\_FsGn0=(+0.00,+0.00,+40.00,+0.00,+0.00,+0.00)(0,0)

'Gain (Specifies Z-axis direction as 40 [10<sup>-3</sup> mm/N].)

P\_FsFLm0=(+20.00,+20.00,+5.00,+5.00,+5.00,+5.00)(0,0)

'Force detection setting value (Specifies Z-axis direction as 5 [N].)

P\_FsFCd0=(+0.00,+0.00,+0.00,+0.00,+0.00,+0.00)(0,0)

'Force control (no specification)

,

Def Act 1,P\_FsLmtR.Z=1 GoTo \*PCEN,S

'Defines so that interrupt processing is performed if the Z-axis direction becomes smaller than force detection setting value.

P2=P1

P2.X=P2.X+100

'Searches for width of 100 mm in X-direction.

Fsc On,0,0,1

'Enables force sense control with control mode=0, control characteristics =0, and offset cancel enabled.

Mvs P1

'Moves to search start position (Moves approximately -10 mm in the Z-axis direction from the search plane to a low position, and then pushes in the Z-direction.)

,

Spd 5

Act 1=1

For M1=1 To 10

'Searches in 5 mm intervals in the Y-direction. Force is lost in the Z-axis direction if the robot axis drops into a hole, and therefore an interrupt is entered.

Mvs P1

Mvs P2

P1.Y=P1.Y+5

P2.Y=P1.Y

Mvs P2

Mvs P1

P1.Y=P1.Y+5

P2.Y=P1.Y

Next M1

Act 1=0

Fsc Off

End

,

'Interrupt processing

\*PCEN

Dim PX(2),PY(2)

P0=P\_Curr

'The position at which the robot axis falls into the hole and stops is used as a reference.

---

```

PX(1)=P0
PX(2)=P0
PY(1)=P0
PY(2)=P0
PX(1).X=P0.X+10      'The position ±10 mm in the XY-direction from the reference position is calculated.
PX(2).X=P0.X-10
PY(1).Y=P0.Y+10
PY(2).Y=P0.Y-10
'

Fsc Off
P_FsFLm0=(+2.00,+2.00,+5.00,+5.00,+5.00,+5.00)(0,0)    'Changes the X,Y-axis direction force detection setting value to 2 [N].
Fsc On,0,0,1
MFLG=0
'

For M1=1 To 2
Mvs PX(M1) Wthlf P_FsLmtR.X=1,Skip 'Moves ±10 mm in the X-axis direction and skips if the force detection setting is exceeded.
If M_SkipCq=1 Then
PX(M1)=P_FsLmtP      'If skipped, the position at which the force detection setting value is exceeded is retained.
MFLG=MFLG+1
EndIf
Mvs P0
Fsc Off              'Force sense control is temporarily enabled to reset P_FsLmtP.
Fsc On,0,0,1
Next M1
'

For M1=1 To 2
Mvs PY(M1) Wthlf P_FsLmtR.Y=1,Skip ' Moves ±10 mm in the Y-axis direction and skips if the force detection setting is exceeded.
If M_SkipCq=1 Then
PY(M1)=P_FsLmtP      'If skipped, the position at which the force detection setting value is exceeded is retained.
MFLG=MFLG+1
EndIf
Mvs P0
Fsc Off              ' Force sense control is temporarily enabled to reset P_FsLmtP.
Fsc On,0,0,1
Next M1
'

If MFLG=4 Then      '4 points are found.
  PTMP=(PX(1)+PX(2))/2
  P0.X=PTMP.X      'The X-axis direction center position is set for P0.
  PTMP=(PY(1)+PY(2))/2
  P0.Y=PTMP.Y      ' The Y-axis direction center position is set for P0.
Else                '4 points are not found.
  Error 9100        'Elicits error L9100.
EndIf
End

```

#### ■ Example 4 (Sample Program FB04.prg)

The robot moves at the specified speed in the Z-direction to make contact with the target object. If the Z-axis direction robot position and force sensor data satisfy the specified conditions following contact, the robot starts moving in the Y-axis direction while pushing in the Z-axis direction.

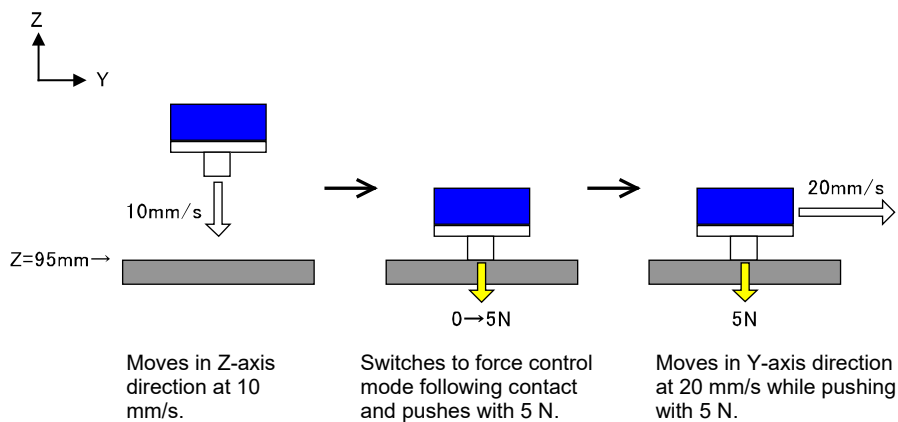

```

M_FsCod0 = 0                                ' Specifies the tool coordinate system.
P_FsMod0 = (0, 1, 1, 0, 0, 0)(0, 0)         'Specifies a force control in the Y/Z-axis direction.
'Control characteristics group ( 0 ) setting
P_FsFCd0 = (0, 0, 5, 0, 0, 0)(0, 0)         'Specifies a force control of 5 N in the Z-axis direction.
P_FsSpd0 = (0, 0, 10, 0, 0, 0)(0, 0)        'Specifies a speed of 10 mm/s in the Z-axis direction.
P_FsSwF0 = (0, 0, 0.5, 0, 0, 0)(0, 0)       'Specifies a switching judgment value of 0.5 N in the Z-axis direction.
P_FsGn0 = (0, 0, 10, 0, 0, 0)(0, 0)         Sets a force control gain of 10*10-3 mm/N in the Z-axis direction.
:   'No movement is made in the Y-axis direction and so 0 is specified.
:
'Control characteristics group ( -1 ) setting
P_FsFCd1 = (0, 3, 5, 0, 0, 0, 0, 0)(0, 0)   'Specifies a force control of 3 N in the Y-axis direction, and the Z-axis direction is left at 5 N.
P_FsSpd1 = (0, 20, 0, 0, 0, 0, 0, 0)(0, 0) 'Specifies a speed of 20 mm/s in the Y-axis direction.
:   'Force control is maintained in the Z-axis direction and so 0 mm/s is specified.
P_FsSwF1 = (0, 2, 0, 0, 0, 0, 0, 0)(0, 0)   'Specifies a switching judgment value of 2 N in the Y-axis direction.
P_FsGn1 = (0, 10, 10, 0, 0, 0, 0, 0)(0, 0)  'Sets a force control gain of 10*10-3 mm/N in the Y-axis direction.
:   '( Moves the robot in the Y-axis direction.)
:
Def MoTrg 1, (P_Fbc.Z < 100) And (P_FsCurD.Z > 4.8) 'Defines Mo trigger No.1.
SetMoTrg 1                                     'Enables Mo trigger No.1.
Fsc On, 0, 0, 1                               'Enables force control for control characteristics 0.
Wait M_MoTrg(1) = 1                           'Moves in the Z-direction until the trigger when contact made with the target
:   object turns ON.
Dly 3   'Waits for settling after contact.
FsCTrg 1, 100, -1                             'Mo trigger No.1 is ON and so the control characteristics changed to -1.
:   'Movement starts in the Y-axis direction while pushing with 5 N in the Z-axis direction.
:

```

# 12 Parameter Specifications

This Chapter describes parameters relating to the force sense function.

## 12.1 Force Sense Function Related Parameter List

Table 12-1 Force sense control related parameters

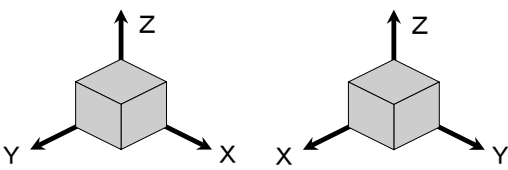
| Parameter                              | Parameter Name | No. of Elements | Description                                                                                                                                                                                                                                                                                                                                                                                                                                                                                                                                                                                                                        | Factory Default Setting                                                                                                                                   |
|----------------------------------------|----------------|-----------------|------------------------------------------------------------------------------------------------------------------------------------------------------------------------------------------------------------------------------------------------------------------------------------------------------------------------------------------------------------------------------------------------------------------------------------------------------------------------------------------------------------------------------------------------------------------------------------------------------------------------------------|-----------------------------------------------------------------------------------------------------------------------------------------------------------|
| Force sense interface unit recognition | AXJNO          | 16 integers     | Sets the force sense interface unit or additional axis number for the element corresponding to the servo control axis number being used.<br><If using force sense interface unit><br>Servo control axis No.: Set "9" for axis No.1.                                                                                                                                                                                                                                                                                                                                                                                                | 0, 0, 0, 0,<br>0, 0, 0, 0,<br>0, 0, 0, 0,<br>0, 0, 0, 0                                                                                                   |
|                                        | AXMENO         | 16 integers     | Enter a mechanical number corresponding to the servo control axis number being used. Always set "0" for axes that are not being used.                                                                                                                                                                                                                                                                                                                                                                                                                                                                                              | 0, 0, 0, 0,<br>0, 0, 0, 0,<br>0, 0, 0, 0,<br>0, 0, 0, 0                                                                                                   |
| Calibration                            | FSHAND         | 1 integer       | <p>Selects the force sensor coordinate system hand system (left-hand system/right-hand system).<br/>The force sensor coordinate system hand system differs depending on the sensor attachment direction, and therefore it is necessary to change the setting based on the attachment direction.<br/>Set the left-hand system for recommended attachment.</p> <p>0: Force sensor coordinate system left-hand system<br/>1: Force sensor coordinate system right-hand system</p> <p>&lt;Left-hand system&gt;      &lt;Right-hand system&gt;</p>  | 0                                                                                                                                                         |
|                                        | FSXTL          | 6 real numbers  | <p>Sets the positional relationship for the mechanical interface coordinate system and force sensor coordinate system.</p> <p>1st element: X-axis direction coordinate system origin offset [mm]<br/>2nd element: Y-axis direction coordinate system origin offset [mm]<br/>3rd element: Z-axis direction coordinate system origin offset [mm]<br/>4th element: Coordinate axis rotation angle around X-axis [deg]<br/>5th element: Coordinate axis rotation angle around Y-axis [deg]<br/>6th element: Coordinate axis rotation angle around Z-axis [deg]</p>                                                                     | <p>0.0, 0.0, 0.0,<br/>0.0, 180.0, 0.0<br/>(vertical multi-joint robots)</p> <p>0.0, 0.0, 0.0,<br/>0.0, 0.0, 180.0<br/>(horizontal multi-joint robots)</p> |
| Force sensor tolerance                 | FSLMTMX        | 6 real numbers  | <p>Sets the force sensor tolerance.<br/>If sensor data exceeding the force and moment set at this parameter is detected, an error (H7660) occurs and the robot is stopped.<br/>(Force sense control will be disabled.)</p> <p>1st element: Force sensor data Fx tolerance [N]<br/>2nd element: Force sensor data Fy tolerance [N]<br/>3rd element: Force sensor data Fz tolerance [N]<br/>4th element: Force sensor data Mx tolerance [N·m]<br/>5th element: Force sensor data My tolerance [N·m]<br/>6th element: Force sensor data Mz tolerance [N·m]</p>                                                                        | 0.0, 0.0, 0.0,<br>0.0, 0.0, 0.0,<br>0.0, 0.0                                                                                                              |
| Force sense control offset limit       | FSCORMX        | 2 real numbers  | <p>Sets the maximum position offset for force sense control.</p> <p>1st element: Position maximum offset [mm]<br/>2nd element: Posture maximum offset [deg.]<br/>[Setting range]<br/>1st element: 0 to +200.0<br/>2nd element: 0 to +150.0</p>                                                                                                                                                                                                                                                                                                                                                                                     | 10.0, 10.0                                                                                                                                                |
| Force sensor data filter               | FSFLCTL        | 1 real number   | <p>Sets the force sensor data filter time constant.<br/>[Unit]: ms<br/>[Setting range]: 0 to +1000.0</p>                                                                                                                                                                                                                                                                                                                                                                                                                                                                                                                           | 1.7                                                                                                                                                       |



| Parameter                          | Parameter Name  | No. of Elements | Description                                                                                                                                                                                                                                                                                                                                                                                                                                                                                                                                                                                                                                                            | Factory Default Setting                                             |
|------------------------------------|-----------------|-----------------|------------------------------------------------------------------------------------------------------------------------------------------------------------------------------------------------------------------------------------------------------------------------------------------------------------------------------------------------------------------------------------------------------------------------------------------------------------------------------------------------------------------------------------------------------------------------------------------------------------------------------------------------------------------------|---------------------------------------------------------------------|
| Force sensor minimum force control | FSMINCTL        | 6 real number   | Sets the minimum force control for the force sensor.<br>1st element: Minimum force control setting value for force sensor Fx [N]<br>2nd element: Minimum force control setting value for force sensor Fy [N]<br>3rd element: Minimum force control setting value for force sensor Fz [N]<br>4th element: Minimum force control setting value for force sensor Mx [Nm]<br>5th element: Minimum force control setting value for force sensor My [Nm]<br>6th element: Minimum force control setting value for force sensor Mz [Nm]<br>(Controller Ver. R6h/S6h or later)                                                                                                  | 0.3, 0.3, 0.3,<br>0.03, 0.03, 0.03                                  |
| Force sensor calibration data      | FSEST01<br>~09  | 12 real number  | Sets the robot's posture and the force sensor data used for the force sensor calibration execution.<br>1st element: Robot position X [mm]<br>2nd element: Robot position Y [mm]<br>3rd element: Robot position Z [mm]<br>4th element: Robot posture A [deg]<br>5th element: Robot posture B [deg]<br>6th element: Robot posture C [deg]<br>7th element: Force sensor data Fx [N]<br>8th element: Force sensor data Fy [N]<br>9th element: Force sensor data Fz [N]<br>10th element: Force sensor data Mx [Nm]<br>11th element: Force sensor data My [Nm]<br>12th element: Force sensor data Mz [Nm]<br><br>(The value is updated at the FsGetDat command is executed.) | 0.0, 0.0, 0.0,<br>0.0, 0.0, 0.0,<br>0.0, 0.0, 0.0,<br>0.0, 0.0, 0.0 |
| Control mode                       | FSCOD01<br>-09  | 1 integer       | Specifies the force sense coordinate system. (See section 8.1.2.1 .)<br>0: Tool coordinate system<br>1: XYZ coordinate system<br>[Setting range]: 0, 1                                                                                                                                                                                                                                                                                                                                                                                                                                                                                                                 | 0                                                                   |
|                                    | FSFMD01<br>-09  | 8 integers      | Selects the force sense control mode for each coordinate system axis. (See section 8.1.2.2 .)<br>0: Position control<br>1: Force control<br>2: Stiffness control<br>3: Limited stiffness control<br>[Setting range]: 0, 1, 2, 3                                                                                                                                                                                                                                                                                                                                                                                                                                        | 0, 0, 0, 0,<br>0, 0, 0, 0                                           |
|                                    | FSSTF01 -<br>09 | 8 integers      | Sets the stiffness coefficient for force sense control (stiffness control). (See section 8.1.2.3 .)<br>[Setting range]: 0.0 - 1000.0<br>[Setting unit]: X, Y, Z axes = N/mm<br>A, B, C axes = N·m/deg<br>(This setting is not required for axes for which stiffness control is not selected.)                                                                                                                                                                                                                                                                                                                                                                          | 0.0, 0.0, 0.0,<br>0.0, 0.0, 0.0,<br>0.0, 0.0                        |
|                                    | FSDMP01<br>-09  | 8 real numbers  | Sets the damping coefficient (responsiveness) for force sense control. (See section 8.1.2.4 .)<br>[Setting range]: 0.0 - 1.0<br>[Setting unit]: X, Y, Z axes = N/(mm/s),<br>A, B, C axes = N·m/(deg/s)                                                                                                                                                                                                                                                                                                                                                                                                                                                                 | 0.0, 0.0, 0.0,<br>0.0, 0.0, 0.0,<br>0.0, 0.0                        |

| Parameter               | Parameter Name | No. of Elements | Description                                                                                                                                                                                                                                                                                                                                                                                                                                                                                                                                                                                                                                                                                                                                                                                                                                                                                                                                                                             | Factory Default Setting                      |
|-------------------------|----------------|-----------------|-----------------------------------------------------------------------------------------------------------------------------------------------------------------------------------------------------------------------------------------------------------------------------------------------------------------------------------------------------------------------------------------------------------------------------------------------------------------------------------------------------------------------------------------------------------------------------------------------------------------------------------------------------------------------------------------------------------------------------------------------------------------------------------------------------------------------------------------------------------------------------------------------------------------------------------------------------------------------------------------|----------------------------------------------|
| Control mode            | FSBIAS01-09    | 6 real numbers  | Sets the bias value used for gravity offset cancel.<br><br>1st element: Force sensor data Fx bias value [N]<br>2nd element: Force sensor data Fy bias value [N]<br>3rd element: Force sensor data Fz bias value [N]<br>4th element: Force sensor data Mx bias value [N·m]<br>5th element: Force sensor data My bias value [N·m]<br>6th element: Force sensor data Mz bias value [N·m]<br><br>(These values because these are set automatically by the force calibration function, so you do not need to be set again.)                                                                                                                                                                                                                                                                                                                                                                                                                                                                  | 0.0, 0.0, 0.0,<br>0.0, 0.0, 0.0              |
|                         | FSGRP01-09     | 6 real numbers  | Sets the load center of gravity position used for gravity offset cancel.<br><br>1st element: Load center of gravity position X [mm]<br>2nd element: Load center of gravity position Y [mm]<br>3rd element: Load center of gravity position Z [mm]<br>4th element: Rotation angle of load center of gravity A [deg]<br>5th element: Rotation angle of load center of gravity B [deg]<br>6th element: Rotation angle of load center of gravity C [deg]<br><br>(These values because these are set automatically by the force calibration function, so you do not need to be set again.)                                                                                                                                                                                                                                                                                                                                                                                                   | 0.0, 0.0, 0.0,<br>0.0, 0.0, 0.0              |
|                         | FSMASS01 - 09  | 1 real number   | Sets the load mass used for gravity offset cancel.<br><br>[Setting unit]: kg<br>(These values because these are set automatically by the force calibration function, so you do not need to be set again.)                                                                                                                                                                                                                                                                                                                                                                                                                                                                                                                                                                                                                                                                                                                                                                               | 0.0                                          |
| Control characteristics | FSCMD01 - 09   | 8 real numbers  | The value has different roles in the force control and the limited stiffness control.<br><br>[In the case of force control]<br>Sets the force command for force sense control (force control). (See section 8.1.2.5 .)<br>[Setting range]: - force sensor tolerance value to + force sensor tolerance value<br>[Setting unit]: X, Y, Z component = N<br>A, B, C component = N·m<br>(This setting is not required for axes for which force control is not selected.)<br><br>[In the case of the stiffness control with limit]<br>Sets the limit value for the limited stiffness control. (See section 8.1.2.6 .)<br>[Setting range]: 0 to + force sensor tolerance value<br>[Setting unit]: X, Y, Z, L1 component = N<br>(L1 component sets the limit value for the resultant force.)<br>A, B, C, L2 component = N·m<br>(L2 component sets the limit value for the resultant moment.)<br><br>(The value is not required in the axis that is not applying the limited stiffness control.) | 0.0, 0.0, 0.0,<br>0.0, 0.0, 0.0,<br>0.0, 0.0 |
|                         | FSSPD01 - 09   | 8 real numbers  | Sets the speed command value for force sense control (force control). (See section 8.1.2.7 .)<br>[Setting range]: 0.0 - 50.0<br>[Setting unit]: X, Y, Z component = mm/s<br>A, B, C component = deg/s<br>(This setting is not required for axes for which force control is not selected.)                                                                                                                                                                                                                                                                                                                                                                                                                                                                                                                                                                                                                                                                                               | 0.0, 0.0, 0.0,<br>0.0, 0.0, 0.0,<br>0.0, 0.0 |

| Parameter                              | Parameter Name | No. of Elements    | Description                                                                                                                                                                                                                                                                                                                                                                                                                                                                                              | Factory Default Setting                           |
|----------------------------------------|----------------|--------------------|----------------------------------------------------------------------------------------------------------------------------------------------------------------------------------------------------------------------------------------------------------------------------------------------------------------------------------------------------------------------------------------------------------------------------------------------------------------------------------------------------------|---------------------------------------------------|
| Control characteristics                | FSSWF01-09     | 8 real numbers     | Sets the mode switching judgment value for force sense control (force control). (See section 8.1.2.8.)<br>[Setting range]: - force sensor tolerance value to + force sensor tolerance value<br>[Setting unit]: X, Y, Z component = N<br>A, B, C component = N·m<br>(This setting is not required for axes for which force control is not selected.)                                                                                                                                                      | 0.0, 0.0, 0.0,<br>0.0, 0.0, 0.0,<br>0.0, 0.0      |
| Filter time constant for offset cancel | FSFLOFST       | 1 real number      | Sets the filter time constant used for gravity offset cancel.<br>It is not required to change this value in normal use.<br><br>[Setting range] : 0 or more<br>[Setting unit] : ms                                                                                                                                                                                                                                                                                                                        | 30.0                                              |
| Control characteristics                | FSFGN01-09     | 8 real numbers     | Sets the force sense control gain (response sensitivity) for force sense control. (See section 8.1.2.9.)<br>[Setting range]: 0.0 - 300.0<br>[Setting range]: X, Y, Z axis component = 10 <sup>-3</sup> mm/N<br>A, B, C axis component = 10 <sup>-3</sup> deg/(N·m)                                                                                                                                                                                                                                       | 0.0, 0.0, 0.0,<br>0.0, 0.0, 0.0,<br>0.0, 0.0      |
|                                        | FSFLMT01-09    | 6 real numbers     | Sets the force detection setting for interrupt signals and data retention trigger for each coordinate axis. (See section 8.1.2.10.)<br>[Setting range]: 0.0 - force sensor tolerance value<br>[Setting range]: X, Y, Z axis component = N<br>A, B, C axis component = N·m                                                                                                                                                                                                                                | 2000.0, 2000.0,<br>2000.0, 200.0,<br>200.0, 200.0 |
| Log function                           | FSLOGFN        | 3 integers         | Specifies settings for the force sense log function.<br>1st element: Enables/disables the log function.<br>[Setting range]<br>0 (disable), 1 (enable)<br><br>2nd element: Selects the collected force sensor data type.<br>[Setting range]<br>0: Raw data (with offset cancel)<br>1: Raw data (without offset cancel)<br>2: Data after coordinate conversion (offset cancel designation updated)<br><br>3rd element: Specifies whether to use/not use FTP.<br>[Setting range]<br>0 (Do not use), 1 (Use) | 0, 2, 0                                           |
|                                        | FTPID          | 1 character string | Sets the user ID used with FsOutLog command FTP communication.<br>1st element: user ID<br>[Setting range]: Up to 8 single-byte alphanumeric characters (upper/lower case)                                                                                                                                                                                                                                                                                                                                | ftpuser                                           |
|                                        | FTPPASS        | 1 character string | Sets the password used with FsOutLog command FTP communication.<br>1st element: password<br>[Setting range]<br>Up to 16 single-byte alphanumeric characters (upper/lower case), or single-byte symbols (! # \$ % & = - @ . ? _)                                                                                                                                                                                                                                                                          | ftppassword                                       |
|                                        | FTPSVRIP       | 1 character string | Sets the FTP server IP address used with FsOutLog command FTP communication.<br>1st element: IP address<br>[Setting range]<br>"0.0.0.0" - "255.255.255.255"                                                                                                                                                                                                                                                                                                                                              | 192.168.0.99                                      |

## 12.2 RT ToolBox2 Force Sense Function Parameter Setting Screen

### (1) Force sensor settings

This screen is used to set the force sense control function default parameters. It is necessary to reboot the controller after setting parameters.

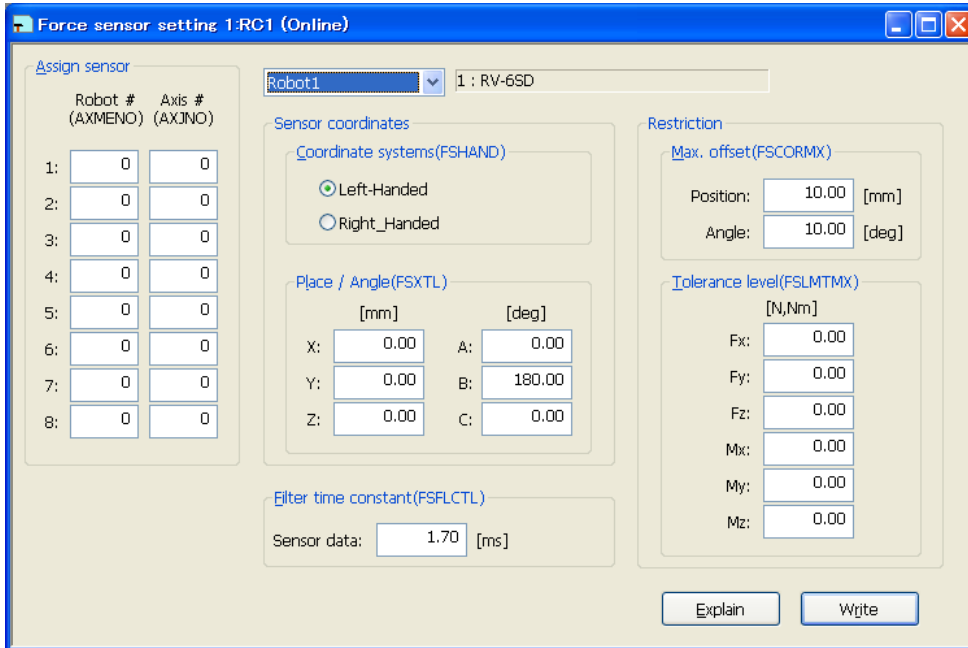

Fig. 12-1: Force sensor setting screen

### (2) Force control mode

This screen is used to set the control mode for force sense control. Parameter settings are updated immediately, and therefore there is no need to reboot the controller.

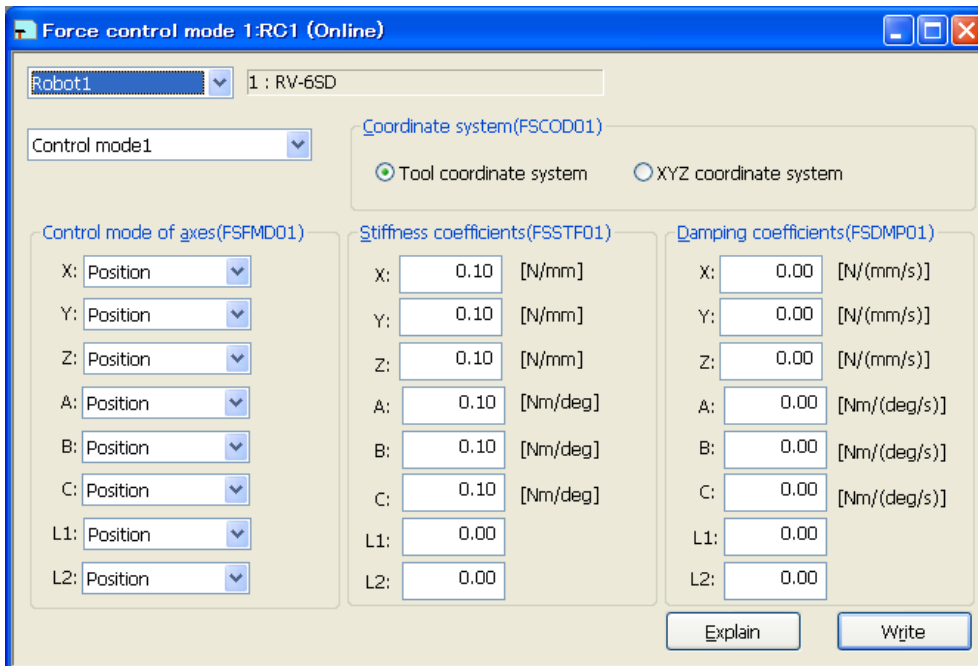
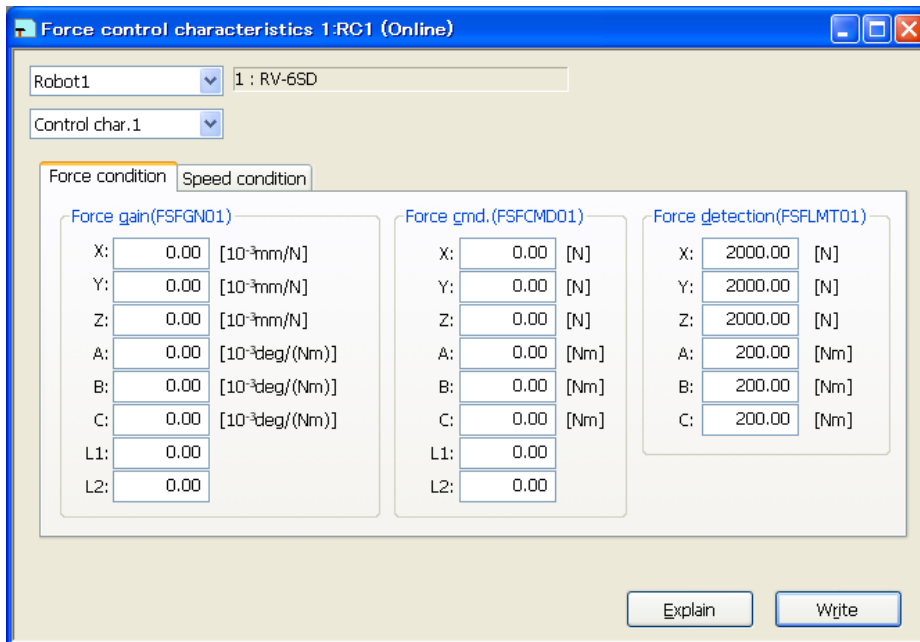

Fig. 12-2: Force control mode screen

(3) Force control characteristics

This screen is used to set the control characteristics for force sense control. Parameter settings are updated immediately, and therefore there is no need to reboot the controller.



[Force condition] tab



[Speed condition] tab

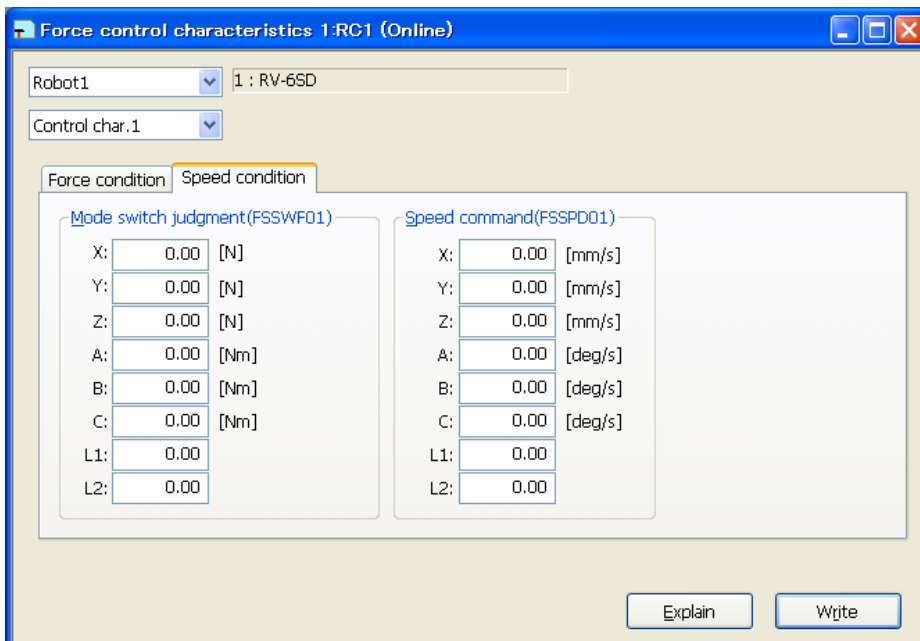

Fig. 12-3: Force control characteristics screen

(4) Force log setting

This screen is used to set parameters for the force sense log function. It is necessary to reboot the controller after writing parameters.

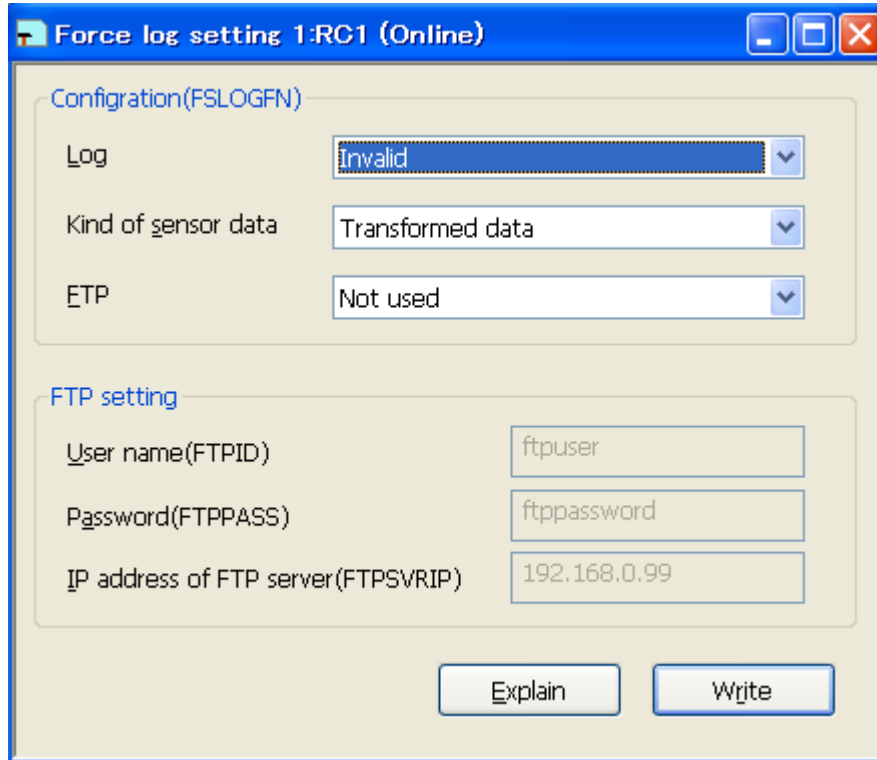

Fig. 12-4: Force log setting screen

## 12.3 R56TB/R57TB Force Sense Function Parameter Setting Screen

### (1) Initial settings

This screen is used to set the force sense control function default parameters. It is necessary to reboot the controller after setting parameters.

| Designation<br>Robot #<br>(AXMENO) | Setting<br>axis #<br>(AXJNO) |
|------------------------------------|------------------------------|
| 1:                                 | 7                            |
| 2:                                 | 9                            |
| 3:                                 | 1                            |
| 4:                                 | 2                            |
| 5:                                 | 3                            |
| 6:                                 | 1                            |
| 7:                                 | 2                            |
| 8:                                 | 3                            |

| [mm]    | [deg]     |
|---------|-----------|
| X: 0.00 | A: 180.00 |
| Y: 0.00 | B: 0.00   |
| Z: 0.00 | C: 0.00   |

| [N,Nm]   |
|----------|
| Fx: 1.01 |
| Fy: 2.02 |
| Fz: 3.03 |
| Mx: 4.04 |
| My: 5.05 |
| Mz: 6.06 |

Delay: 1.70 [ms]

Fig. 12-5: Force sense control Initial setting screen

### (2) Force control mode

This screen is used to set the control mode for force sense control. Parameter settings are updated immediately, and therefore there is no need to reboot the controller.

| X:       | Y:       | Z:       | A:       | B:       | C:       | L1:      | L2:      |
|----------|----------|----------|----------|----------|----------|----------|----------|
| Position | Position | Position | Position | Position | Position | Position | Position |

| X:          | Y:          | Z:          | A:            | B:            | C:            | L1:  | L2:  |
|-------------|-------------|-------------|---------------|---------------|---------------|------|------|
| 0.10 [N/mm] | 0.10 [N/mm] | 0.10 [N/mm] | 0.10 [Nm/deg] | 0.10 [Nm/deg] | 0.10 [Nm/deg] | 0.00 | 0.00 |

| X:              | Y:              | Z:              | A:                | B:                | C:                | L1:  | L2:  |
|-----------------|-----------------|-----------------|-------------------|-------------------|-------------------|------|------|
| 0.00 [N/(mm/s)] | 0.00 [N/(mm/s)] | 0.00 [N/(mm/s)] | 0.00 [Nm/(deg/s)] | 0.00 [Nm/(deg/s)] | 0.00 [Nm/(deg/s)] | 0.00 | 0.00 |

Fig. 12-6: Force control mode screen

(3) Force control characteristics

This screen is used to set the control characteristics for force sense control. Parameter settings are updated immediately, and therefore there is no need to reboot the controller.

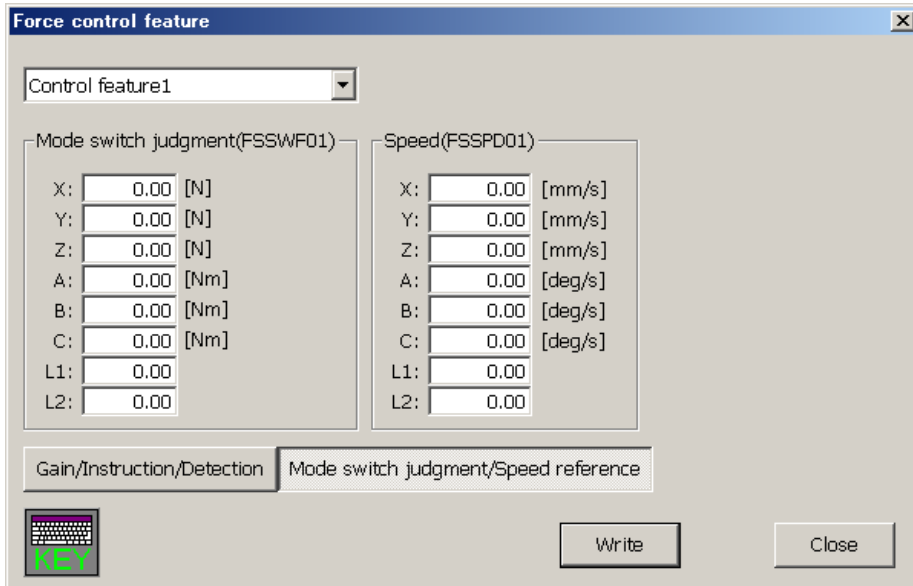
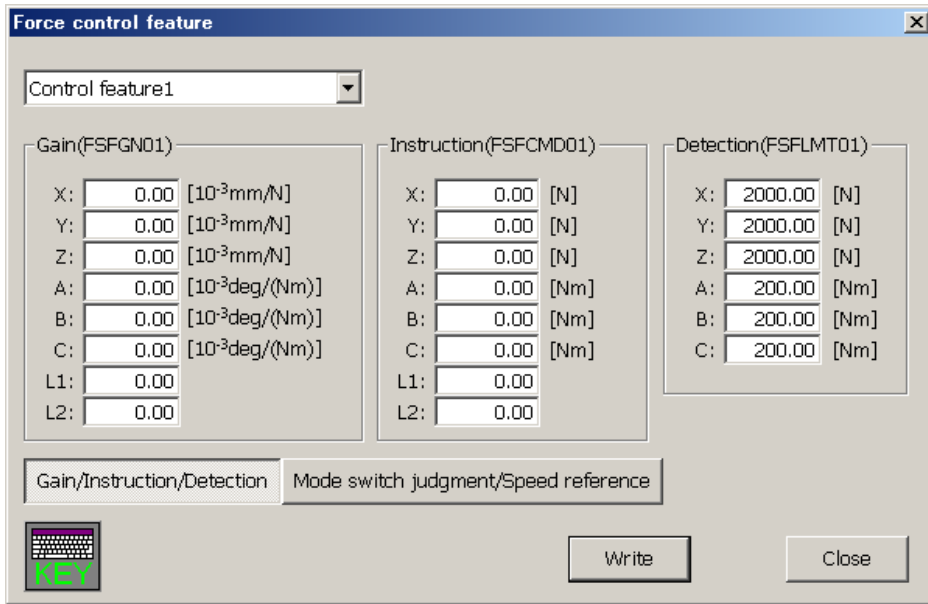

Fig. 12-7: Force control feature screen



#### (4) Force log setting

This screen is used to set parameters for the force sense log function. It is necessary to reboot the controller after writing parameters.

Force log setting

Configuration(FSLOGFN)

Log: Valid

Kind of sensor data: Transformed data

FTP: Used

FTP setting

User name(FTPID): ftpuser2

Password(FTPPASS): ftppassword2

IP address of FTP server(FTPSVRIP): 192.168.0.99

KEY

Write

Close

Fig. 12-8: Force log setting screen

# 13 Troubleshooting

## 13.1 Behavior when Force Sense Control Errors Occur

If any of the following types of error occurs, force sense control is disabled and the servo turns OFF.

**Table 13-1: Behavior when force sense control error occurs**

| Type                         | Error No. | Error Details                                         |
|------------------------------|-----------|-------------------------------------------------------|
| Force sense position command | H2760     | Offset limit over                                     |
|                              | H3988     | Force sense position command calculation not possible |
|                              | H2770     | Outside joint movement range                          |
|                              | H2780     | Speed over                                            |
| Force sense I/F unit         | H8920     | Force sense interface unit error                      |
| Force sensor data            | H7660     | Sensor tolerance over                                 |

## 13.2 Force Sense Function Related Error List

The following error numbers consist of 4 digits + 5 digits. The first 4 digits appear on the operation panel and teaching pendant. The last 5 digits can be checked at the RT ToolBox2 error details display. (See below.)

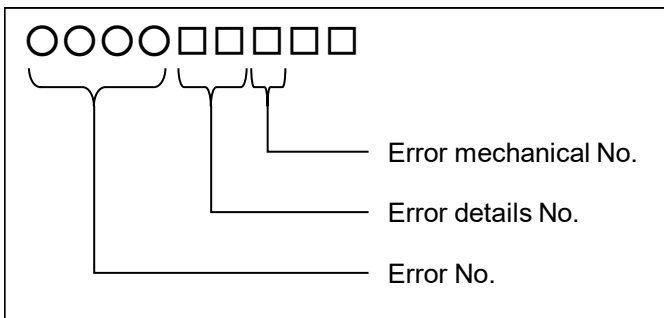
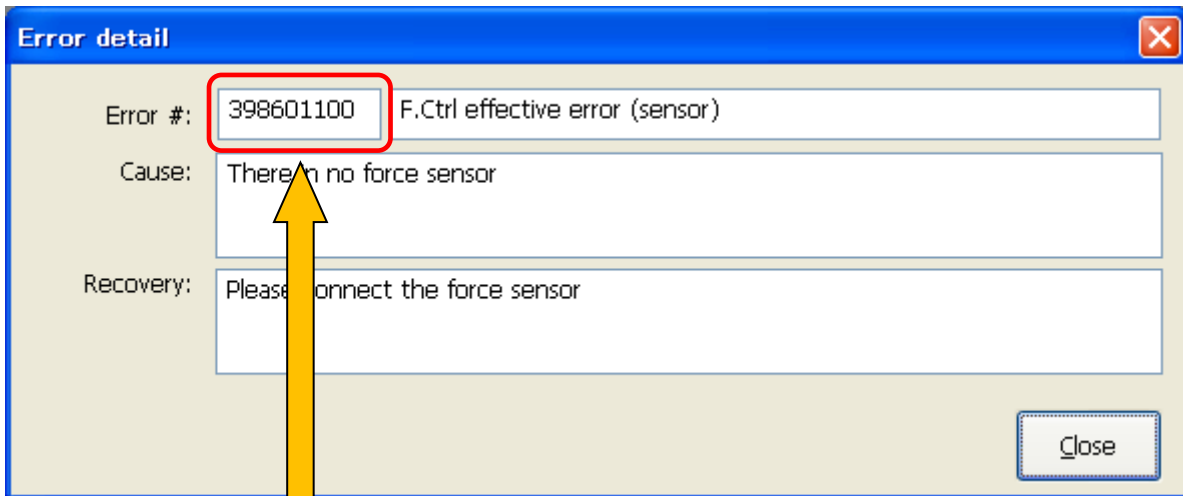

Table 13-2 Error List

| Error No.    | Error Details                                                                                                         |
|--------------|-----------------------------------------------------------------------------------------------------------------------|
| L_1864_00000 | The FTP communication parameters are incorrect.                                                                       |
| L_2750_01000 | Unable to disable force sense control while tracking.                                                                 |
| H_2760_00000 | The force sense control offset value was approaching the limit value. (★)                                             |
| H_2770_00000 | The force sense control offset position is outside the movement range. (★)                                            |
| H_2780_00000 | The force sense control offset position exceeded the speed limit. (★)                                                 |
| L_3110_76000 | A value outside the range was set for the force sense control command argument.                                       |
| L_3110_77000 | A value outside the range was set for the force sense control status variable argument.                               |
| L_3110_78000 | A value outside the range was set for a force sense control related argument.                                         |
| L_3110_80000 | A value outside the range was set for the Mo trigger No.                                                              |
| L_3110_81000 | A value outside the range was set for the Def MoTrg command argument.                                                 |
| L3770_00000  | An attempt was made to use an undefined Mo trigger.                                                                   |
| L_3870_17000 | An invalid value was set for the force sense control status variable mechanical No.                                   |
| L_3870_22000 | The mechanical No. specified with the Def MoTrg command is invalid.                                                   |
| L_3986_01000 | Unable to enable force sense function. (Force sensor not connected)                                                   |
| L_3986_02000 | Unable to enable force sense function. (Compliance control function enabled)                                          |
| L_3986_04000 | Unable to enable compliance control function. (Force sense control function enabled)                                  |
| L_3986_05000 | Unable to enable collision detection function. (Force sense control function enabled)                                 |
| L_3986_07000 | Unable to enable force sense function. (Initialization failure)                                                       |
| L_3986_08000 | Unable to move the singular point adjacent area. (Force sense control function enabled)                               |
| L_3986_09000 | The force sense control enabled/disabled status differs from that when operation is interrupted.                      |
| L_3986_10000 | This force sense control function cannot be used.                                                                     |
| L_3986_11000 | Unable to change tool conversion data. (Force sense control function enabled)                                         |
| L_3986_12000 | Unable to change base conversion data. (Force sense control function enabled)                                         |
| L_3986_13000 | Unable to execute Jrc command. (Force sense control function enabled)                                                 |
| L_3986_14000 | Unable to perform JOG operation. (Force sense control function enabled)                                               |
| L_3986_16000 | Unable to perform offset cancel. (Force sense control function enabled)                                               |
| L_3987_01000 | The force sense control function is disabled.                                                                         |
| L_3987_02000 | An attempt was made to enable force sense control while enabled.                                                      |
| L_3987_04000 | An attempt was made to execute an FsGChg command during force sense control gain change processing.                   |
| L_3987_07000 | Failed to output a force sense log file to the FTP server.                                                            |
| L_3987_08000 | The specified force sense log file does not exist.                                                                    |
| L_3987_10000 | Unable to change force sense control status variable settings. (Force sense control function enabled)                 |
| L_3987_11000 | Unable to create/output another file while creating/outputting a force sense log file.                                |
| L_3987_12000 | Unable to create force sense log file.                                                                                |
| L_3987_14000 | Unable to execute Fsc On command while changing the gain.                                                             |
| L_3987_16000 | Unable to execute Fsc On command while registering log data.                                                          |
| L_3987_26000 | Unable to change force sense control parameter settings. (Force sense control function enabled)                       |
| L_3987_27000 | Unable to enable Mo trigger. (The FsCTrg command Mo trigger executed first is enabled.)                               |
| L_3987_28000 | Mo trigger timeout. The Mo trigger did not turn ON within the specified time.                                         |
| L_3987_29000 | Unable to executed FsCTrg command. (Changing control characteristics)                                                 |
| L_3987_30000 | Unable to executed FsCTrg command. (The FsCTrg command Mo trigger executed first is enabled.)                         |
| L_3987_31000 | Unable to specify control characteristics change. A control characteristics change has been set with another command. |
| L_3987_40000 | FsHndEst command is not executed                                                                                      |
| L_3987_41000 | Input data error(F.Ctrl Calib)                                                                                        |
| L_3987_42000 | Calculation error(F.Ctrl Calib)                                                                                       |
| H_3988_00000 | Unable to convert linear position data to joint angle after offsetting with force control. (★)                        |
| H_7650_00000 | The force sensor quantity setting is incorrect.                                                                       |
| H_7651_00000 | Unable to initialize force sense interface unit.                                                                      |
| H_7652_00000 | This is a force sense interface unit for an unsupported revision.                                                     |
| H_7660_02000 | The force acting on the sensor exceeded the tolerance value. (★)                                                      |
| H_8920_00000 | Force sense interface unit error (★)                                                                                  |
| C_8921_00000 | Force sense interface unit warning                                                                                    |

(★) Force sense control is disabled if an error occurs while force sense control is enabled.

## 13.3 Force Control Function Related Error Details

(The power must be reset for errors with \* in the Error No. "First 4 Digits" field.)

| Error No.      |                                           | Error Cause and Remedy |                                                                                                                                                                                                                   |
|----------------|-------------------------------------------|------------------------|-------------------------------------------------------------------------------------------------------------------------------------------------------------------------------------------------------------------|
| First 4 Digits | Last 5 Digits                             |                        |                                                                                                                                                                                                                   |
| L1864          | 00000                                     | Err. message           | FTP parameter setting error (**)<br>*) "*" is substituted with the "parameter name".                                                                                                                              |
|                |                                           | Cause                  | The FTP communication parameter setting lies outside the range.                                                                                                                                                   |
|                |                                           | Remedy                 | Check the setting and correct.                                                                                                                                                                                    |
| L2750          | 01n00<br>n=Mech.<br>No.                   | Err. message           | Unable to disable force sense control. (Tracking being performed)                                                                                                                                                 |
|                |                                           | Cause                  | Unable to disable force sense control while tracking function being executed.                                                                                                                                     |
|                |                                           | Remedy                 | Try again after disabling the tracking function.                                                                                                                                                                  |
| H.2760         | 00n00<br>n=Mech.<br>No.                   | Err. message           | The force sense control offset limit was reached.                                                                                                                                                                 |
|                |                                           | Cause                  | The robot attempted to move beyond the force sense control offset limit.                                                                                                                                          |
|                |                                           | Remedy                 | Check whether there is a problem with robot movement while force sense control is enabled.<br>(The offset limit is the value set in parameter FSCORMX.)                                                           |
| H.2770         | xxn00<br>xx=Axis<br>No.<br>n=Mech.<br>No. | Err. message           | Outside offset position movement range (**)<br>*) "*" is substituted with "±Jn" (n is axis No.)                                                                                                                   |
|                |                                           | Cause                  | The position after force sense control offset lies outside the range.<br>The robot may have been moved near the movement range limit.                                                                             |
|                |                                           | Remedy                 | Review the movement position or force sense control settings, and ensure that the offset position does not exceed the movement range.                                                                             |
| H.2780         | 0xn00<br>x=Axis No.<br>n=Mech.<br>No.     | Err. message           | Offset position speed over (**)<br>*) "*" is substituted with "Jn" (n is axis No.)                                                                                                                                |
|                |                                           | Cause                  | The speed of movement to the position after offsetting with force sense control exceeded the speed limit.<br>The movement speed may be too fast, or the robot may have been moved at the singular point adjacent. |
|                |                                           | Remedy                 | Review the movement speed and movement position, or the force sense control settings.                                                                                                                             |
| L.3110         | 76n00<br>n=Mech.<br>No.                   | Err. message           | The force sense control command argument lies outside the range.                                                                                                                                                  |
|                |                                           | Cause                  | A value outside the range was set for the force sense control command argument.                                                                                                                                   |
|                |                                           | Remedy                 | Check the argument range and set a correct value.                                                                                                                                                                 |
| L.3110         | 77n00<br>n=Mech.<br>No.                   | Err. message           | The force sense control status variable argument lies outside the range.                                                                                                                                          |
|                |                                           | Cause                  | A value outside the range was set for the force sense control status variable argument.                                                                                                                           |
|                |                                           | Remedy                 | Check the argument range and set a correct value.                                                                                                                                                                 |
| L.3110         | 78n00<br>n=Mech.<br>No.                   | Err. message           | The force sense control related argument lies outside the range.                                                                                                                                                  |
|                |                                           | Cause                  | A value outside the range was set for the force sense control related argument.                                                                                                                                   |
|                |                                           | Remedy                 | Check the argument range and set a correct value.                                                                                                                                                                 |
| L.3110         | 80n00<br>n=Mech.<br>No.                   | Err. message           | The Mo trigger No. lies outside the range.                                                                                                                                                                        |
|                |                                           | Cause                  | A value outside the range was set for the Mo trigger No.                                                                                                                                                          |
|                |                                           | Remedy                 | Check the setting range and set a correct value.                                                                                                                                                                  |
| L.3110         | 81n00<br>n=Mech.<br>No.                   | Err. message           | Def MoTrg command argument error                                                                                                                                                                                  |
|                |                                           | Cause                  | An unusable variable or different mechanical No. was set.                                                                                                                                                         |
|                |                                           | Remedy                 | Set a usable variable or same mechanical No.                                                                                                                                                                      |
| L.3770         | 00n00<br>n=Mech.<br>No.                   | Err. message           | This is an undefined Mo trigger.                                                                                                                                                                                  |
|                |                                           | Cause                  | An attempt was made to use an undefined Mo trigger.                                                                                                                                                               |
|                |                                           | Remedy                 | Define the specified Mo trigger before use.                                                                                                                                                                       |
| L.3870         | 17000                                     | Err. message           | The force sense control status variable mechanical No. is an invalid value.                                                                                                                                       |
|                |                                           | Cause                  | An invalid variable was set for the force sense control status variable mechanical No.                                                                                                                            |
|                |                                           | Remedy                 | Set a correct mechanical No.                                                                                                                                                                                      |

| Error No.      |                         | Error Cause and Remedy |                                                                                                                                                                                          |
|----------------|-------------------------|------------------------|------------------------------------------------------------------------------------------------------------------------------------------------------------------------------------------|
| First 4 Digits | Last 5 Digits           |                        |                                                                                                                                                                                          |
| L.3870         | 22000                   | Err. message           | The mechanical No. specified with the Def MoTrg command is an invalid value.                                                                                                             |
|                |                         | Cause                  | The mechanical No. specified with the Def MoTrg command is an invalid value.                                                                                                             |
|                |                         | Remedy                 | Set a correct mechanical No.                                                                                                                                                             |
| L.3986         | 01n00<br>n=Mech.<br>No. | Err. message           | Unable to enable force sense control. (Sensor)                                                                                                                                           |
|                |                         | Cause                  | Unable to execute because the force sensor is not connected.                                                                                                                             |
|                |                         | Remedy                 | Connect the force sensor, or delete the command that cause the error.                                                                                                                    |
| L.3986         | 02n00<br>n=Mech.<br>No. | Err. message           | Unable to enable force sense control. (Cmp command)                                                                                                                                      |
|                |                         | Cause                  | It is not possible to enable force sense control function while the compliance control function is enabled.                                                                              |
|                |                         | Remedy                 | The force sense control function and compliance control function cannot be enabled simultaneously. If using the force sense control function, disable the compliance control function.   |
| L.3986         | 04n00<br>n=Mech.<br>No. | Err. message           | Unable to execute the Cmp command. (Force sense control)                                                                                                                                 |
|                |                         | Cause                  | It is not possible to enable the compliance control function while the force sense control function is enabled.                                                                          |
|                |                         | Remedy                 | The force sense control function and compliance control function cannot be enabled simultaneously. If using the compliance control function, disable the force sense control function.   |
| L.3986         | 05n00<br>n=Mech.<br>No. | Err. message           | Unable to enable the collision detection function. (Force sense control)                                                                                                                 |
|                |                         | Cause                  | It is not possible to enable the collision detection function while force sense control function is enabled.                                                                             |
|                |                         | Remedy                 | The force sense control function and collision detection function cannot be enabled simultaneously. If using the collision detection function, disable the force sense control function. |
| L.3986         | 07n00<br>n=Mech.<br>No. | Err. message           | Unable to enable force sense control. (Initialization)                                                                                                                                   |
|                |                         | Cause                  | It is not possible to perform initialization when starting force sense control.                                                                                                          |
|                |                         | Remedy                 | Check the parameter settings.                                                                                                                                                            |
| L.3986         | 08n00<br>n=Mech.<br>No. | Err. message           | This is the singular point adjacent area. (Force sense control)                                                                                                                          |
|                |                         | Cause                  | It is not possible to move the singular point adjacent area while the force sense control function is enabled.                                                                           |
|                |                         | Remedy                 | If moving the singular point adjacent area, disable the force sense control function.                                                                                                    |
| L.3986         | 09n00<br>n=Mech.<br>No. | Err. message           | The force sense control status is different.                                                                                                                                             |
|                |                         | Cause                  | The force sense control enabled/disabled status when resuming program operation differs from that during program operation.                                                              |
|                |                         | Remedy                 | Set the force sense control enabled/disabled status to the correct status. (This occurs only once when resuming program operation.)                                                      |
| L.3986         | 10n00<br>n=Mech.<br>No. | Err. message           | This function cannot be used.                                                                                                                                                            |
|                |                         | Cause                  | This model is not compatible with the executed force sense control function.                                                                                                             |
|                |                         | Remedy                 | Do not use this force sense control function.<br>Contact the maker for details on the latest compatibility status.                                                                       |
| L.3986         | 11n00<br>n=Mech.<br>No. | Err. message           | Unable to change tool conversion data. (Force sense control)                                                                                                                             |
|                |                         | Cause                  | It is not possible to change tool conversion data while the force sense control function is enabled.                                                                                     |
|                |                         | Remedy                 | If changing tool conversion data, disable the force sense control function.                                                                                                              |
| L.3986         | 12n00<br>n=Mech.<br>No. | Err. message           | Unable to change base conversion data. (Force sense control)                                                                                                                             |
|                |                         | Cause                  | It is not possible to change base conversion data while the force sense control function is enabled.                                                                                     |
|                |                         | Remedy                 | If changing base conversion data, disable the force sense control function.                                                                                                              |
| L.3986         | 13n00<br>n=Mech.<br>No. | Err. message           | Unable to execute the Jrc command. (Force sense control)                                                                                                                                 |
|                |                         | Cause                  | It is not possible to execute the Jrc command while the force sense control function is enabled.                                                                                         |
|                |                         | Remedy                 | To execute the Jrc command, disable the force sense control function.                                                                                                                    |

| Error No.      |                         | Error Cause and Remedy |                                                                                                                                              |
|----------------|-------------------------|------------------------|----------------------------------------------------------------------------------------------------------------------------------------------|
| First 4 Digits | Last 5 Digits           |                        |                                                                                                                                              |
| L.3986         | 14n00<br>n=Mech.<br>No. | Err. message           | Disable force sense control.                                                                                                                 |
|                |                         | Cause                  | JOG operation cannot be performed on your model while the force sense control function is enabled.                                           |
|                |                         | Remedy                 | Disable the force sense control function.                                                                                                    |
| L.3986         | 16n00<br>n=Mech.<br>No. | Err. message           | Unable to perform offset cancel. (Force sense control)                                                                                       |
|                |                         | Cause                  | It is not possible to perform offset cancel while the force sense control function is enabled.                                               |
|                |                         | Remedy                 | If performing offset cancel, disable the force sense control function.                                                                       |
| L.3987         | 01n00<br>n=Mech.<br>No. | Err. message           | Force sense control is disabled.                                                                                                             |
|                |                         | Cause                  | Force sense control is disabled, and so unable to execute the command.                                                                       |
|                |                         | Remedy                 | Enable the force sense control function.                                                                                                     |
| L.3987         | 02n00<br>n=Mech.<br>No. | Err. message           | Force sense control is enabled.                                                                                                              |
|                |                         | Cause                  | It is not possible to enable force sense control again while already enabled.                                                                |
|                |                         | Remedy                 | First disable the force sense control function, and then enable again.                                                                       |
| L.3987         | 04n00<br>n=Mech.<br>No. | Err. message           | Unable to execute the FsGChg command.                                                                                                        |
|                |                         | Cause                  | It is not possible to execute the FsGChg command when force control gain change is not complete.                                             |
|                |                         | Remedy                 | Review the program so that the FsGChg command is executed after force control gain change is complete.                                       |
| L.3987         | 07n00<br>n=Mech.<br>No. | Err. message           | Unable to output log file.                                                                                                                   |
|                |                         | Cause                  | FTP processing was not properly performed.                                                                                                   |
|                |                         | Remedy                 | Check the FTP related parameter setting.<br>Check the Ethernet cable connection.<br>Check the FTP server settings at the computer.           |
| L.3987         | 08n00<br>n=Mech.<br>No. | Err. message           | The specified log file does not exist.                                                                                                       |
|                |                         | Cause                  | The log file for the No. specified with the FsOutLog command does not exist.                                                                 |
|                |                         | Remedy                 | Check whether the log file No. is incorrect.                                                                                                 |
| L.3987         | 10n00<br>n=Mech.<br>No. | Err. message           | Unable to change the force sense status variable.                                                                                            |
|                |                         | Cause                  | The status variable setting is currently being used by the force sense control function and so cannot be changed.                            |
|                |                         | Remedy                 | If changing the setting, disable the force sense control function.                                                                           |
| L.3987         | 11n00<br>n=Mech.<br>No. | Err. message           | Force sense log commands executed simultaneously.                                                                                            |
|                |                         | Cause                  | It is not possible to create/output another file while creating (FsLog Off command) or outputting (FsOutLog command) a force sense log file. |
|                |                         | Remedy                 | Process after force sense log file creation/output is complete.                                                                              |
| L.3987         | 12n00<br>n=Mech.<br>No. | Err. message           | Unable to create log file.                                                                                                                   |
|                |                         | Cause                  | Unable to create a force sense log file.                                                                                                     |
|                |                         | Remedy                 | Check the amount of available record space in the robot controller.                                                                          |
| L.3987         | 14n00<br>n=Mech.<br>No. | Err. message           | Unable to execute the Fsc ON command.                                                                                                        |
|                |                         | Cause                  | It is not possible to execute the Fsc On command while changing the force control gain.                                                      |
|                |                         | Remedy                 | Execute the Fsc On command after force control gain change is complete.                                                                      |
| L.3987         | 16n00<br>n=Mech.<br>No. | Err. message           | Unable to perform log data related processing.                                                                                               |
|                |                         | Cause                  | It is not possible to execute FsLog On command file while recording force sense control log data.                                            |

| Error No.      |                         | Error Cause and Remedy |                                                                                                                                                                                                 |
|----------------|-------------------------|------------------------|-------------------------------------------------------------------------------------------------------------------------------------------------------------------------------------------------|
| First 4 Digits | Last 5 Digits           |                        |                                                                                                                                                                                                 |
|                |                         | Remedy                 | Execute the FsLog On command after log data recording is complete.                                                                                                                              |
| L.3987         | 26n00<br>n=Mech.<br>No. | Err. message           | Force sense control is enabled.                                                                                                                                                                 |
|                |                         | Cause                  | The parameter setting is currently being used by the force sense control function and so cannot be changed.                                                                                     |
|                |                         | Remedy                 | If changing the parameter, disable the force sense control function once..                                                                                                                      |
| L.3987         | 27n00<br>n=Mech.<br>No. | Err. message           | Unable to enable the Mo trigger.                                                                                                                                                                |
|                |                         | Cause                  | The Mo trigger for the FsCtrg command executed first is enabled.                                                                                                                                |
|                |                         | Remedy                 | Execute after changing the control characteristics.                                                                                                                                             |
| L.3987         | 28n00<br>n=Mech.<br>No. | Err. message           | Mo trigger timeout                                                                                                                                                                              |
|                |                         | Cause                  | The Mo trigger did not turn ON within the specified time.                                                                                                                                       |
|                |                         | Remedy                 | Review the Mo trigger conditions and robot program.                                                                                                                                             |
| L.3987         | 29n00<br>n=Mech.<br>No. | Err. message           | Unable to execute the FsCTrg command.                                                                                                                                                           |
|                |                         | Cause                  | The control characteristics is currently being changed.                                                                                                                                         |
|                |                         | Remedy                 | Execute after changing the control characteristics.                                                                                                                                             |
| L.3987         | 30n00<br>n=Mech.<br>No. | Err. message           | Unable to execute the FsCTrg command.                                                                                                                                                           |
|                |                         | Cause                  | The Mo trigger for the FsCTrg command executed first is enabled.                                                                                                                                |
|                |                         | Remedy                 | Execute after changing the control characteristics.                                                                                                                                             |
| L.3987         | 31n00<br>n=Mech.<br>No. | Err. message           | Unable to specify the control characteristics change.                                                                                                                                           |
|                |                         | Cause                  | The control characteristics change has been set with another command.                                                                                                                           |
|                |                         | Remedy                 | Change the program so that the command is not executed at the same time as another command.                                                                                                     |
| L.3987         | 40n00<br>n=Mech.<br>No. | Err. message           | FsHndEst command is not executed                                                                                                                                                                |
|                |                         | Cause                  | Cannot execute without FsHndEst On command                                                                                                                                                      |
|                |                         | Remedy                 | Please execute FsHndEst command and then execute FsGetDat                                                                                                                                       |
| L.3987         | 41n00<br>n=Mech.<br>No. | Err. message           | Input data error(F.Ctrl Calib)                                                                                                                                                                  |
|                |                         | Cause                  | Input data for the force sensor calibration is illegal                                                                                                                                          |
|                |                         | Remedy                 | Please confirm data for the force sensor calibration                                                                                                                                            |
| L.3987         | 42n00<br>n=Mech.<br>No. | Err. message           | Calculation error(F.Ctrl Calib)                                                                                                                                                                 |
|                |                         | Cause                  | Calculation result of the force sensor calibration is illegal                                                                                                                                   |
|                |                         | Remedy                 | Increase the rotation angle of the calibration operation then get data for the force sensor calibration again.                                                                                  |
| H.3988         | 00n00<br>n=Mech.<br>No. | Err. message           | Unable to create a position command.                                                                                                                                                            |
|                |                         | Cause                  | It is not possible to convert linear position data to joint angle after offsetting with force control.<br>The position after offsetting lies outside the movement range or is a singular point. |
|                |                         | Remedy                 | Review the movement and, settings so that adjacents outside the movement range and singular point adjacents are avoided.                                                                        |
| H.7650         | 00n00<br>n=Mech.<br>No. | Err. message           | The force sensor quantity setting is incorrect.                                                                                                                                                 |
|                |                         | Cause                  | Only 1 force sensor can be used for a single robot.                                                                                                                                             |
|                |                         | Remedy                 | Check the parameter (AXJNO, AXMENO) settings to see whether multiple force sensors have been set.                                                                                               |
| H.7651<br>*    | 00n00<br>n=Mech.<br>No. | Err. message           | Force sense I/F unit initialization error                                                                                                                                                       |
|                |                         | Cause                  | The force sense I/F unit was not recognized, and therefore it was not possible to successfully complete initialization.                                                                         |

| Error No.      |                                             | Error Cause and Remedy |                                                                                                                                                                                                                           |
|----------------|---------------------------------------------|------------------------|---------------------------------------------------------------------------------------------------------------------------------------------------------------------------------------------------------------------------|
| First 4 Digits | Last 5 Digits                               |                        |                                                                                                                                                                                                                           |
|                |                                             | Remedy                 | Check the force sense I/F unit wiring and whether the power supply is ON.                                                                                                                                                 |
| H.7652<br>*    | 00n00<br>n=Mech.<br>No.                     | Err. message           | Force sense I/F unit revision illegal                                                                                                                                                                                     |
|                |                                             | Cause                  | This force sense I/F unit revision is not supported.                                                                                                                                                                      |
|                |                                             | Remedy                 | Contact the maker.                                                                                                                                                                                                        |
| H.766x         | 02n00<br>n=Mech.<br>No.<br>x=Sensor<br>axis | Err. message           | The force sensor data exceeded the tolerance value.                                                                                                                                                                       |
|                |                                             | Cause                  | The force acting on the force sensor exceeded the set tolerance value.                                                                                                                                                    |
|                |                                             | Remedy                 | Check whether too large a force is acting on the force sensor.<br>Check whether an appropriate value has been set for parameter FSLMTMX.<br>* See section <a href="#">6.5.3</a> for details on the error recovery method. |
| H8920          | 00n00<br>n=Mech.<br>No.                     | Err. message           | Sensor I/F unit error (**)<br>*) "*" is substituted with the "sensor I/F unit error No." (2 hexadecimal digits)                                                                                                           |
|                |                                             | Cause                  | An error occurred at the force sensor interface unit.                                                                                                                                                                     |
|                |                                             | Remedy                 | See "Table Table <b>13-3</b> " based on the error No. in the Err. Message.                                                                                                                                                |
| C8921          | 00n00<br>n=Mech.<br>No.                     | Err. message           | Sensor I/F unit warning (**)<br>*) "*" is substituted with the "sensor I/F unit warning No." (2 hexadecimal digits)                                                                                                       |
|                |                                             | Cause                  | A warning occurred at the force sensor interface unit.                                                                                                                                                                    |
|                |                                             | Remedy                 | See "Table Table <b>13-3</b> " based on the warning No. in the Err. Message.                                                                                                                                              |

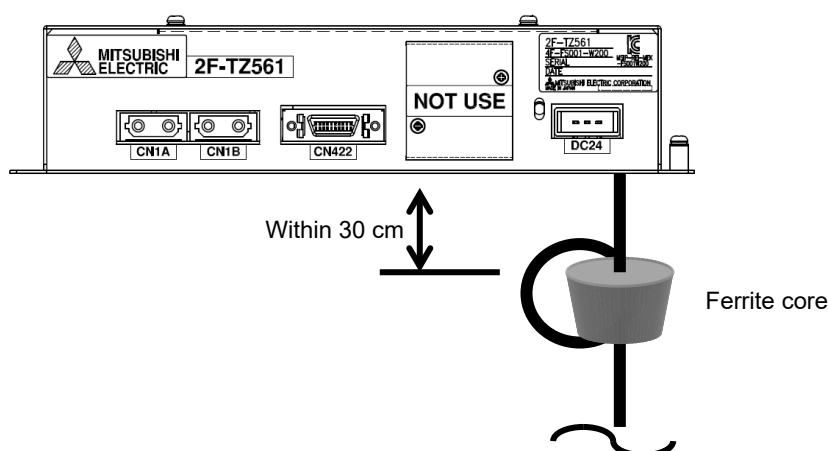

Table 13-3: Force sense interface unit errors

| Error No. (Name)                          | Cause                                                                                                                                                                                                                   | Remedy                                                                                                                                                                                                                                                           |                                                                                                                                                                       |                                                                                                                                                  |
|-------------------------------------------|-------------------------------------------------------------------------------------------------------------------------------------------------------------------------------------------------------------------------|------------------------------------------------------------------------------------------------------------------------------------------------------------------------------------------------------------------------------------------------------------------|-----------------------------------------------------------------------------------------------------------------------------------------------------------------------|--------------------------------------------------------------------------------------------------------------------------------------------------|
| 12 (memory error)                         | Force sense interface unit internal part fault                                                                                                                                                                          | Replace the unit.                                                                                                                                                                                                                                                |                                                                                                                                                                       |                                                                                                                                                  |
| 13 (S/W processing error)                 |                                                                                                                                                                                                                         |                                                                                                                                                                                                                                                                  |                                                                                                                                                                       |                                                                                                                                                  |
| 21 (sensor initial communication error)   | (1) The force sensor connection cable is disconnected.<br>(2) The force sensor connection cable is damaged.<br>(3) Noise contamination occurred.<br>(4) The F2 fuse (0.3 A) in the force sense interface unit is blown. | (1) Connect the cable.<br>(2) Replace the cable.<br>(3) Perform noise countermeasures. (*1)<br>(4) Confirm and correctly connect the force sensor connection cable connector, then replace the F2 fuse (model: LM03) inside the force sense interface unit. (*2) |                                                                                                                                                                       |                                                                                                                                                  |
| 25 (sensor communication error)           |                                                                                                                                                                                                                         |                                                                                                                                                                                                                                                                  |                                                                                                                                                                       |                                                                                                                                                  |
| 34 (communication data error)             |                                                                                                                                                                                                                         |                                                                                                                                                                                                                                                                  | (1) The SSCNET III cable is disconnected.<br>(2) The SSCNET III cable end face is dirty.<br>(3) The SSCNET III cable is damaged.<br>(4) Noise contamination occurred. | (1) Connect after turning OFF the power.<br>(2) Wipe any dirt from the end face.<br>(3) Replace the cable.<br>(4) Perform noise countermeasures. |
| 36 (communication error)                  |                                                                                                                                                                                                                         |                                                                                                                                                                                                                                                                  |                                                                                                                                                                       |                                                                                                                                                  |
| 37 (parameter error)                      |                                                                                                                                                                                                                         |                                                                                                                                                                                                                                                                  |                                                                                                                                                                       |                                                                                                                                                  |
| 38 (communication frame error)            |                                                                                                                                                                                                                         |                                                                                                                                                                                                                                                                  |                                                                                                                                                                       |                                                                                                                                                  |
| 39 (communication axis information error) |                                                                                                                                                                                                                         |                                                                                                                                                                                                                                                                  |                                                                                                                                                                       |                                                                                                                                                  |

\*1: The noise suppression method is shown below. Take the measures against a noise by a method suitable for the environment (if necessary). All the measures are not necessarily required.

- a) Install the noise filter to the power supply of the peripheral equipment.
- b) Attach the ferrite core to the 24 VDC output cable as shown below. When attaching the ferrite core, take care not to apply a weight to the cable and connector.



\*2: Arrangement of the fuse inside the force sense interface unit is shown below.

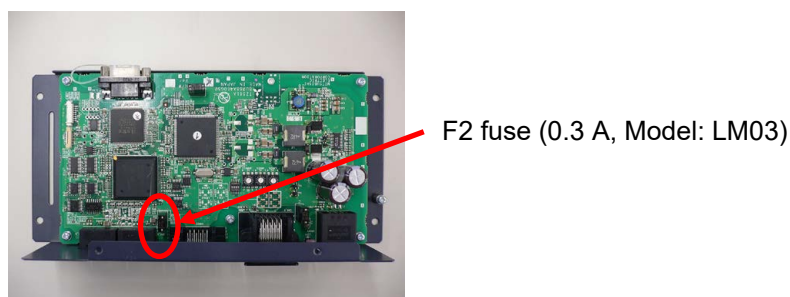

Force sense interface unit internal circuit

## 13.4 Q & A

|                                                                            | Cause                                                                                      | Measures                                                                                                                                                                                                                                            |
|----------------------------------------------------------------------------|--------------------------------------------------------------------------------------------|-----------------------------------------------------------------------------------------------------------------------------------------------------------------------------------------------------------------------------------------------------|
| The robot vibrates during the force sense control.                         | Force sense control gain is high.                                                          | Decrease the force sense control gain. (section <a href="#">8.1.2.9</a> )                                                                                                                                                                           |
|                                                                            | The response sensitivity of the sensor is high.                                            | Increase the filter time constant of the force sensor data. (section <a href="#">6.5.5</a> )                                                                                                                                                        |
|                                                                            | The minimum control force is small.                                                        | Increase the minimum control force of the force sensor. (section <a href="#">6.5.6</a> )                                                                                                                                                            |
| The robot moves to an unintended direction during the force sense control. | Incorrect setting of a calibration parameter.                                              | Confirm the setting of a calibration parameter. (section <a href="#">6.5.2</a> )                                                                                                                                                                    |
|                                                                            | The offset cancel operation (sensor zero point offset) of the sensor is not performed.     | Perform the offset cancel operation. (section <a href="#">8.1.3</a> )                                                                                                                                                                               |
|                                                                            | The offset cancel operation is performed before the robot is completely stopped.           | Use the Dly command etc., and wait until the robot complete stop and the sensor data become stabilizing, and then perform the offset cancel operation of the sensor. (section <a href="#">8.1.3</a> )                                               |
|                                                                            | The offset cancel operation is performed when the external force is applied to the sensor. | Perform the offset cancel operation without the external force applied to the sensor. (section <a href="#">8.1.3</a> )                                                                                                                              |
|                                                                            | The force from a cable etc. is applying.                                                   | Do not attach in such a way as to prevent movement of moveable parts of the force sensor. Confirm the cable fixation place. (section <a href="#">5.2</a> )                                                                                          |
|                                                                            | Incorrect attachment of the sensor.                                                        | Confirm followings.<br><ul style="list-style-type: none"> <li>- Contact between the sensor attachment surface and sensor attachment adapter.</li> <li>- Tightening torque of the built-in bolt of sensor.</li> </ul> (section <a href="#">5.2</a> ) |
| The robot moves like a bouncing on contact during the force sense control. | Force sense control gain is high.                                                          | Decrease the force sense control gain. (section <a href="#">8.1.2.9</a> )                                                                                                                                                                           |
|                                                                            | Operating speed on contact is high.                                                        | When a contact object is hard, decrease the operating speed at the time of contact. (section <a href="#">8.1.2.7</a> )                                                                                                                              |

## 14 Appendix

### 14.1 Control Status Transition

Force sense control has the following 4 statuses.

| Status                      | Description                                                                                                                                                                                                |
|-----------------------------|------------------------------------------------------------------------------------------------------------------------------------------------------------------------------------------------------------|
| Force sense status disabled | This is the force sense control disabled status. This is the status when the power is turned ON.                                                                                                           |
| Offsetting                  | In this status, force sense control is enabled and the robot position is being offset based on the "control mode" and "control characteristics " settings.                                                 |
| Offsetting stopped          | Force sense control is enabled; however, robot position offset processing has been stopped with a stop input or due to an error. (This status is possible only when the key switch is set to "AUTOMATIC".) |
| Processing stopped          | Force sense control is enabled; however, as the servo power is OFF, robot position offset processing is not being performed.                                                                               |

The transition for each status by executing dedicated commands or by turning the servo ON and OFF is as follows.

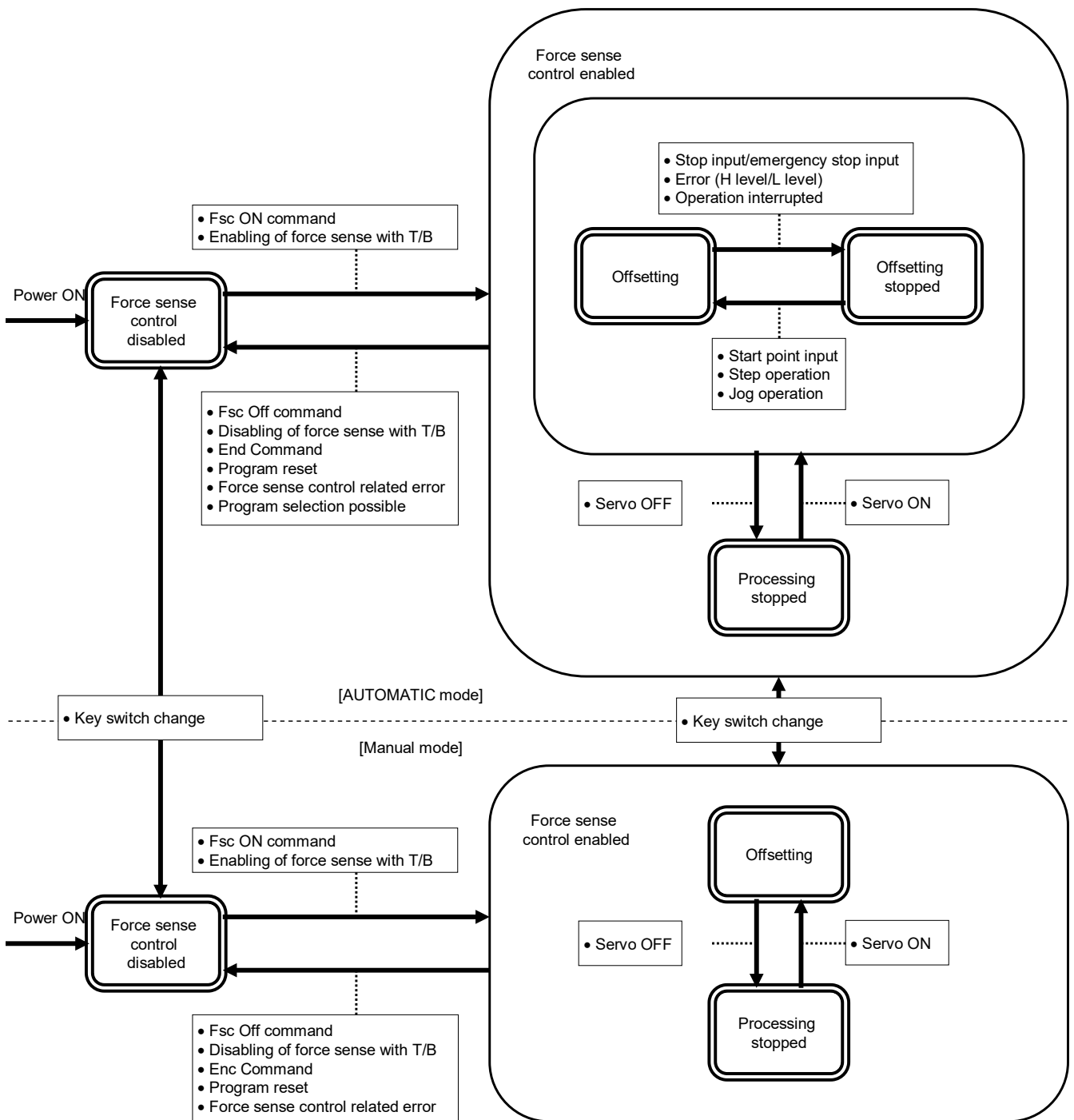

**⚠ Caution**

Stop input in the above diagram refers to a stop input from the operation panel, teaching pendant, I/O, or RT ToolBox2. However, stoppages with the Hlt command and stop inputs by releasing the key during step or JOG operation are not included.

**⚠ Caution**

If a stop is input and the offset amount becomes fixed while pushing with force sense controller the moment contact is made with the target object, error H.094n (servo amplifier overload) or H.096n (servo amplifier error excessive) may occur. (n is axis No.)

**⚠ Caution**

If the operation key switch is set to "MANUAL", robot movement by force sense control will not stop even if a stop is entered. To stop robot movement by force sense control, release the teaching pendant enable switch and turn OFF the servo power.



# **MITSUBISHI ELECTRIC CORPORATION**

HEAD OFFICE: TOKYO BUILDING, 2-7-3, MARUNOUCHI, CHIYODA-KU, TOKYO 100-8310, JAPAN  
NAGOYA WORKS: 5-1-14, YADA-MINAMI, HIGASHI-KU NAGOYA 461-8670, JAPAN

Authorised representative:  
Mitsubishi Electric Europe B.V. FA - European Business Group  
Mitsubishi-Electric-Platz 1, D-40882 Ratingen, Germany  
Tel: +49(0)2102-4860