

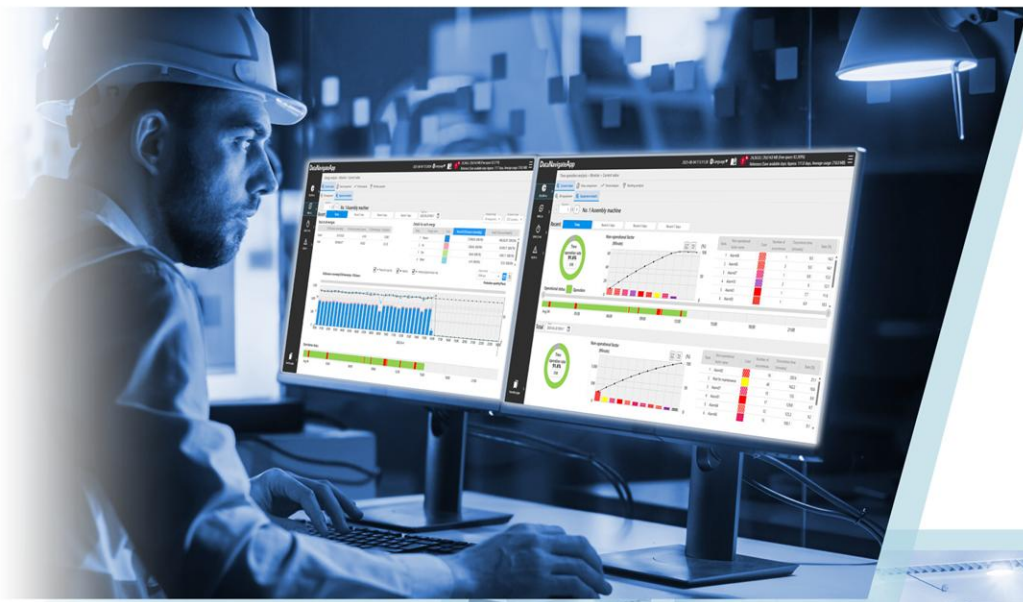

Automating the World
MELSEC iQ-R
series

DataNavigateApp Introduction Guide



TERM OF USE

Use the applications and files upon agreement on the items below.

- (1) These applications and files are available to customers currently using or considering the use of our products.
- (2) The intellectual property rights of the files provided by our company shall belong to our company.
- (3) Alteration, reproduction, transfer, or sales of the files provided by our company is prohibited.
However, the above shall not apply when a part of or all of the contents are used in the devices manufactured by the customer or our products in a system. Also, the above shall not apply to reproduction, duplication, quotation, or layout change in documents such as specifications, design specifications, and instruction manuals for built-in products, created by customers using our products.
- (4) Our company does not compensate for any damage caused by using the files provided by our company and the data extracted from those files. Use them at your own responsibility.
- (5) If any usage conditions are appended to the files provided by our company, those conditions must be observed.
- (6) The specifications described in this document may be changed without prior notice.
- (7) The function descriptions or screen images described in this document may differ from those of the actual product.
- (8) While every effort is made to ensure the contents of this manual are updated to follow the revisions of software and hardware, there may be cases where synchronization cannot be achieved.

PRECAUTIONS FOR USING DataNavigateApp

- (1) Shut down the application before turning off the power.

If the C intelligent function module is powered off without shutting down DataNavigateApp, a file system error or similar issues may occur. Always shut down DataNavigateApp before powering off the C intelligent function module. For the procedure, refer to "5 TERMINATION PROCEDURE".
- (2) Do not change any I/O signal or buffer memory area of the C intelligent function module.

When DataNavigateApp is used, data cannot be written to any I/O signal or buffer memory area of the C intelligent function module. If a value is written, the module may not operate correctly.
- (3) Check carefully when turning on any device with functions such as the alarm notification.

DataNavigateApp has a function that changes the values of pre-specified devices when an alarm occurs. Before setting this function, thoroughly check the security such as ensuring that the equipment does not operate unexpectedly due to the control of the specified device by DataNavigateApp.
- (4) This application cannot be used in conjunction with user programs of the C intelligent function module.

When DataNavigateApp is used, user-created programs cannot be implemented on the C intelligent function module.
- (5) Starting DataNavigateApp may take some time.

Depending on the amount of saved data and usage conditions, it may take time to fully start DataNavigateApp. In addition, device values cannot be collected until DataNavigateApp is fully started. Therefore, turn on the power with sufficient time before the desired collection start timing.
- (6) Precautions for when the time in the terminal used and the clock setting of the CPU module do not match

Various data counted by DataNavigateApp are timestamped based on the clock information of the CPU module. On the other hand, the current date and time information displayed in each window of DataNavigateApp (such as the time displayed at the top of each window) uses the clock information of the terminal (such as the personal computer) displaying windows of DataNavigateApp. Therefore, if the time in the terminal used and the CPU module do not match, the window may not be correctly displayed.
- (7) Changing the clock setting of the CPU module may cause issues.

Various data counted by DataNavigateApp are timestamped based on the clock information of the CPU module. Therefore, if the clock setting of the CPU module is changed, data from before, after, and during the change period may not be counted correctly.

In particular, if the time in the CPU module is changed to a past time, all stored data with timestamps at or after the changed time will be deleted. (Example: If the time is changed from 10:30 to 10:00, all data at or after 10:00 will be deleted.) Take sufficient precautions not to change the time to a past time unintentionally, such as during CPU module battery replacement.
- (8) If free space in the SD memory card is insufficient, data and logs may not be saved.

Collected and counted data is stored in the SD memory card. If the free space in the SD memory card falls to 50 MB or below, data collection will stop. If data collection stops, a notification will be displayed in the upper right corner of the Data Navigate App screen.

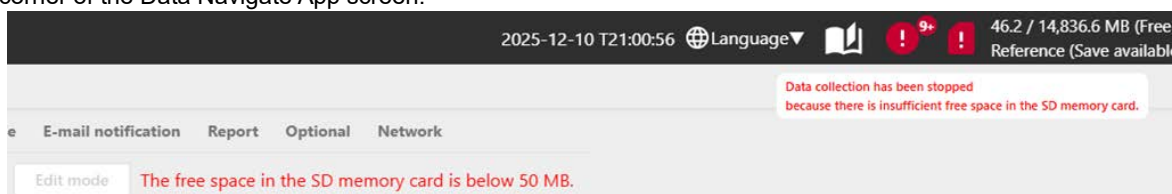

(9) If an SMTP server cannot be configured, the e-mail and daily report functions will not be available.

To use the e-mail and daily report functions, setting an SMTP server is required. If the SMTP server is not set correctly, the e-mail and daily report functions cannot be used.

(10) Depending on the settings, DataNavigateApp may not detect the device status correctly.

The data collection cycle may become longer depending on the settings. If the collection cycle becomes longer and the device value changes in a cycle shorter than the collection cycle, the value change may not be detected.

* The maximum value for the data collection cycle of each equipment can be checked on the Performance window of DataNavigateApp.

(11) Please build and operate a secure FA system according to your usage environment.

For details, refer to "FA SYSTEM SECURITY GUIDELINE" in the MITSUBISHI ELECTRIC Factory Automation website.

https://www.mitsubishielectric.com/fa/about-us/security/pdf/FA_SecGuidelineEN.pdf

CONTENTS

TERM OF USE	1
PRECAUTIONS FOR USING DataNavigateApp	2
CONTENTS	4
1. OVERVIEW	5
1.1. What Is DataNavigateApp?	6
1.2. List of Provided Items.....	7
2. SYSTEM CONFIGURATION	8
2.1. Recommended Hardware	8
2.1.1. Display resolution.....	8
2.2. System Configuration Example.....	9
3. APPLICATION OUTLINE	10
3.1. Time-Based Operation Analysis App	11
3.2. Energy Analysis App.....	15
3.3. Operation Cycle Monitoring App.....	19
3.4. Alarm Analysis App.....	22
4. STARTUP PROCEDURE.....	26
4.1. Procedure for Acquiring a License Key	27
4.2. Procedure for Installing DataNavigateApp	28
4.3. Procedure for Setting the Programmable Controller	30
4.4. Procedure for Accessing DataNavigateApp.....	35
4.5. Procedure for Registering the License Key	42
4.6. Troubleshooting at Startup	43
5. TERMINATION PROCEDURE	48
6. SETTINGS USING THE SUPPORT TOOL	49
6.1. Initial Setting.....	49
6.1.1. Connection destination setting	49
6.1.2. Registration of external IP addresses.....	51
6.2. How to Write Certificates Required for Encrypted Communication	52
6.2.1. E-mail sending.....	52
6.2.2. Web communication	53
6.3. How to Update DataNavigateApp.....	54
7. PROCEDURE FOR UNINSTALLING DataNavigateApp.....	55
REVISIONS	56
TRADEMARKS.....	57

1. OVERVIEW

This document is an introduction guide for DataNavigateApp.
Follow the procedures described in this document to introduce DataNavigateApp.
For the operational method after introduction, refer to Help^{*1} of DataNavigateApp.

*1: Help can be opened with the icon in the red frame in the screenshot below.

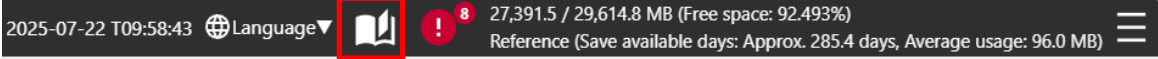

1.1. What Is DataNavigateApp?

DataNavigateApp refers to a dedicated application for the MELSEC iQ-R series C intelligent function module. This application is designed for specific functions such as "visualization" and "analysis" in production sites.

■ Features

(1) Simple settings

Initial setup and setting changes can be performed intuitively.

Settings can be configured without specialized knowledge of programming (ladder and C language).

(2) Monitoring from anywhere

Monitoring can be performed in a web browser on a tablet or personal computer without using a dedicated device such as a display unit.

The operational status of equipment can be checked even from remote locations.

(3) Easy data collection

If data is available in the CPU module, it can be visualized immediately.

This feature can also be used for existing equipment by combining it with the communication function of the CPU module or the like.

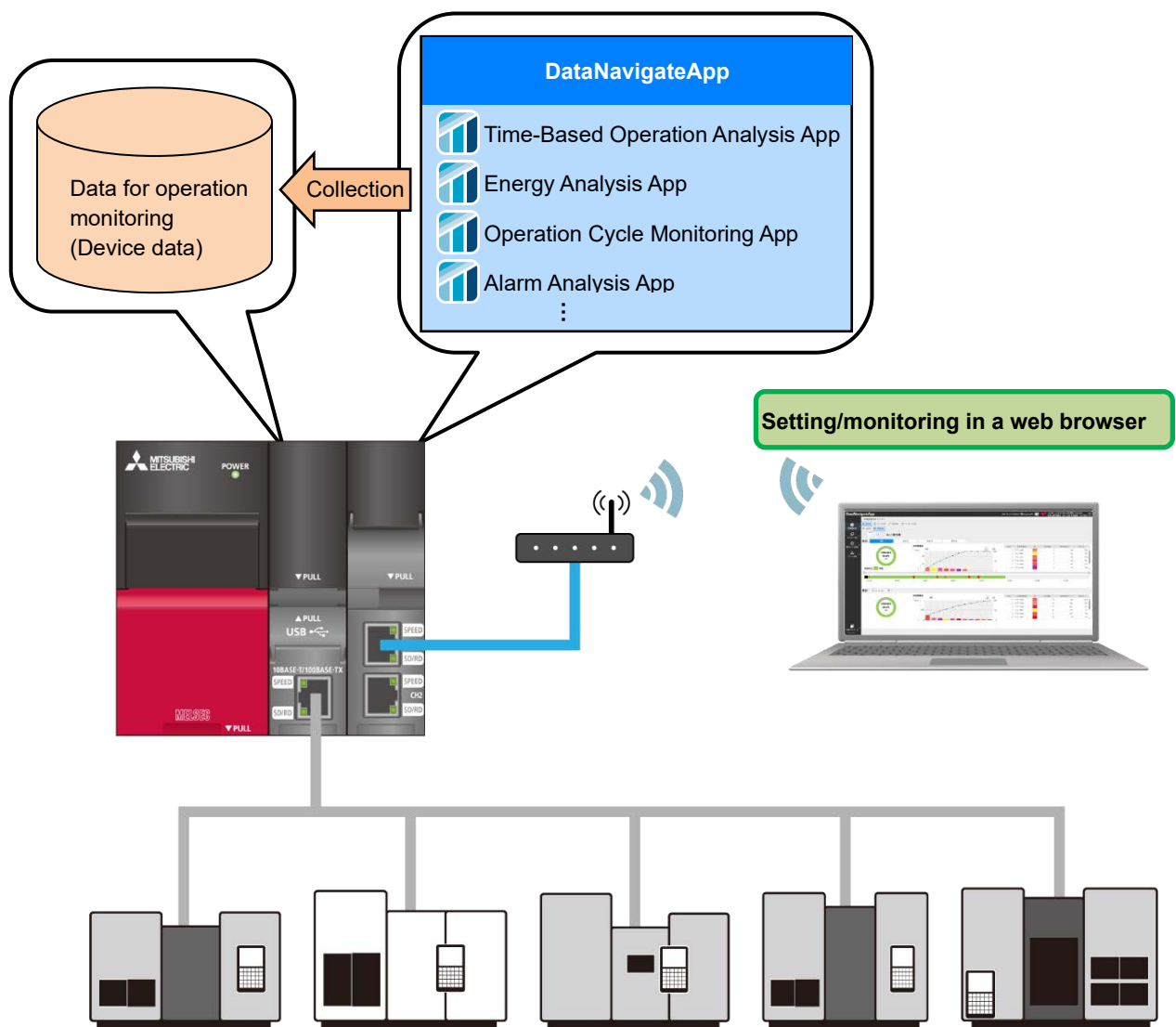

1.2. List of Provided Items

The following table lists the items provided with DataNavigateApp.

No.	Provided item	File name	Outline
1	Software license agreement	End-UserSoftwareLicenseAgreement_ソフトウェア使用契約書(BCN-P5999-1775_BCN-P5999-1776).pdf	A software license agreement for DataNavigateApp. Read this agreement before using the software.
2	Image file for installing DataNavigateApp	DataNavigateApp_v***.ddi *1	An image file for installing DataNavigateApp to a C intelligent function module
3	File for updating DataNavigateApp	DataNavigateApp_UpdateFile_v***.pkg	A file for updating DataNavigateApp using the support tool
4	Introduction guide (Japanese)	bcn899999912***_introductionguide_j.pdf *1	An introduction guide for DataNavigateApp (Japanese)
5	Introduction guide (English) (This guide)	bcn899999913***_introductionguide_e.pdf *1	An introduction guide for DataNavigateApp (English)
6	OSS license file	DataNavigateApp_License_v***.txt	A file containing license information of OSS used for DataNavigateApp
7	Support tool OSS license file	DataNavigateApp_SupportTool_License_v***.txt	A file containing license information of OSS used for the DataNavigateApp support tool
8	Support tool	DataNavigateApp_SupportTool_v***.exe *1	A support tool for performing maintenance of DataNavigateApp

*1: The "****" part indicates the version.

2. SYSTEM CONFIGURATION

2.1. Recommended Hardware

The following table lists the recommended hardware.

Type	Name	Description
MELSEC iQ-R series	CPU module	R04CPU or a CPU module with more capacity ^{*1*2}
	C intelligent function module	RD55UP12-V (Firmware version 06 or later) ^{*3}
	SD memory card	An industrial SD memory card that satisfies the following conditions is recommended. <ul style="list-style-type: none"> Capacity: 16 GB or more NAND type: SLC or pSLC Speed class: Class 10 or higher^{*4} Do not use SD memory cards that are not for industrial purposes (such as those for OA purposes). ^{*5*6}
	Other modules	Select them as necessary. ^{*7}
Supported web browser		Microsoft Edge ^{*8}
		Google Chrome ^{*9}

*1: R00CPU, R01CPU, and R02CPU cannot be used.

*2: Use a CPU module compatible with RD55UP12-V. (Refer to MELSEC iQ-R Module Configuration Manual.)

*3: RD55UP06-V cannot be used.

*4: If the speed class is low, data reading and writing may be delayed, potentially affecting the overall performance of DataNavigateApp.

*5: An SD memory card is required because data is accumulated by constructing a database in the SD memory card. The larger the capacity of the SD memory card, the longer the period for which the data can be stored.

*6: The operation has been checked with the following SD memory cards. As operation may differ depending on your usage environment, use this information as a reference.

Manufacturer name	Model	NAND type	Capacity
HAGIWARA Solutions Co., Ltd.	NSDB-032GK(S01SLS	pSLC	32GB
	NSDB-032GK(S01SLI		
	NSDB-032GS(V02JLS		
TDK Corporation	MMRD4016GVJBWA00AAA0	pSLC	16GB
	MMRD4032GVJBWA00AAA0		32GB

*7: Select and add modules such as an analog input module and network module as necessary.

*8: The operation of DataNavigateApp has been confirmed with Microsoft Edge[®] version 138.

*9: The operation of DataNavigateApp has been confirmed with Google Chrome[®] version 138.

2.1.1. Display resolution

For the resolution of the monitor, 1920 × 1080 (full HD) is recommended.

When the resolution is higher than this, the entire application window can be displayed by adjusting the display scaling. This application can be displayed even on a monitor with a resolution lower than the recommended one, but the text may lose clarity.

2.2. System Configuration Example

The following shows a system configuration example for this sample project.

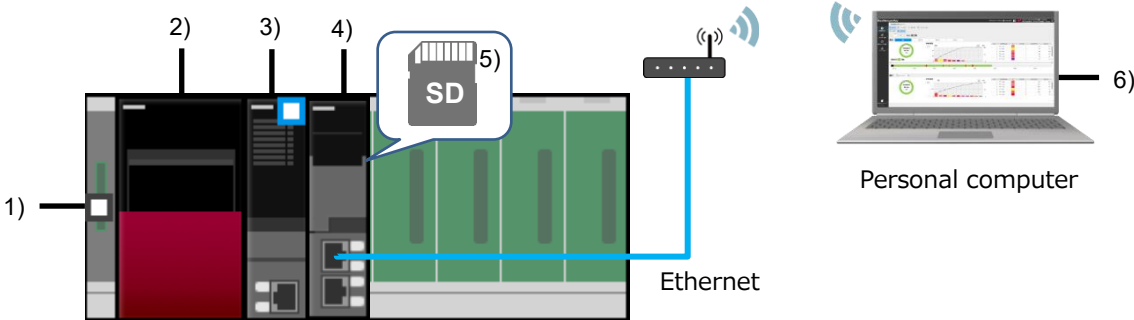

No.	Name	Model
1)	Base unit	R35B
2)	Power supply module	R61P
3)	CPU module	R32CPU
4)	C intelligent function module	RD55UP12-V
5)	SD memory card	NSDB-032GK(S01SLI
6)	Personal computer (Web browser)	-

3. APPLICATION OUTLINE

The following shows the overall specifications of this application.

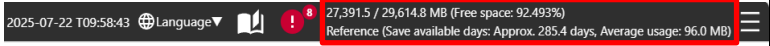
Item	Specifications	Remarks
Number of monitored equipment	Up to 4	The number increases/decreases depending on the number of equipment and applications used. When the number of equipment or applications is large, prepare an SD memory card with a larger capacity. The period for which the data can be stored can be checked on the top right of the window (area in the red frame in the screenshot below). 
Data storage period	Depends on the SD memory card capacity and settings.	
Number of time frames	Up to 100	-
Number of product types	Up to 1000	-
Number of favorite page registrations	Up to 10	-
Number of clients that can be simultaneously connected	Up to 8	Increasing the number of connected clients may slow down screen refresh rate.

3.1. Time-Based Operation Analysis App

This application visualizes the operational status of equipment (such as operating, stopped, and in an error) and loss factors, which can be utilized for analyzing the factors contributing to reduced time operation rates.

1) Recent operational status can be checked.
In the "Current value" window, the recent (up to seven days) time operation rate, load time, and non-operating time of each equipment can be checked in real time. Total operation data for the specified period can be monitored at the same time, allowing you to determine whether any problems are occurring or signs of problems are appearing in the current equipment by comparing the rates of non-operational factors and the actual time operation rates.

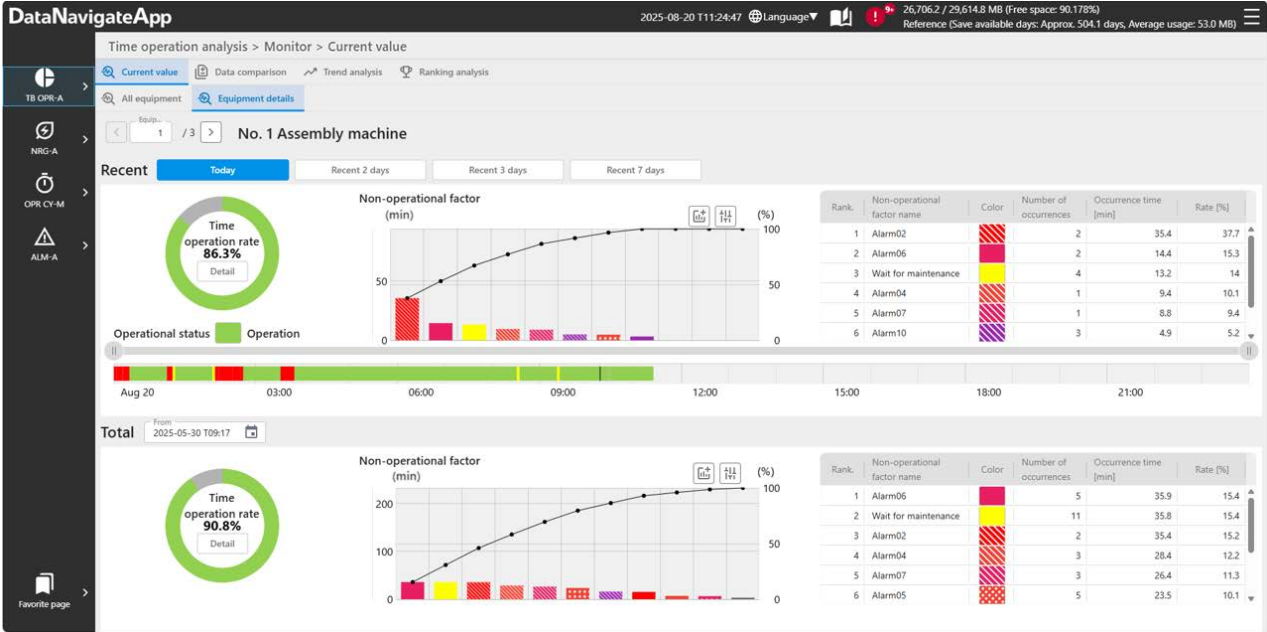

2) Issues causing a reduction in the operation rate can be analyzed.
In the "Data comparison" window, the data under different conditions (such as the equipment, period, and time frame) can be displayed for comparison. For example, waste can be analyzed and improvement effects can be checked by displaying the data from two different dates for the same equipment side by side or displaying the data from two different time frames within the same period for the same equipment for comparison.

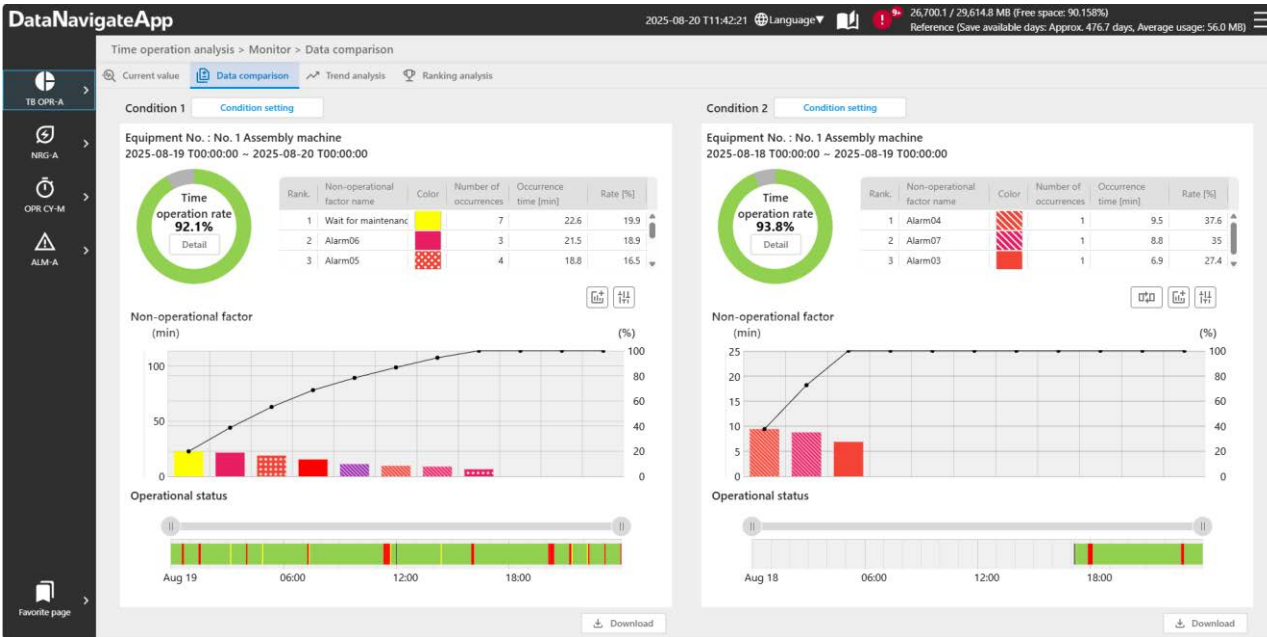

The information displayed as the operational status indicates the equipment operational status being analyzed in "Time-Based Operation Analysis App". If "Time-Based Operation Analysis App" is not used, it will not be displayed.

3) Trends in the time operation rate can be analyzed.

In the "Trend analysis" window, trends such as changes in the time operation rate and occurrence rates of non-operational factors can be checked. Trends based on results can be grasped intuitively, which can be utilized to determine whether future countermeasures are necessary. In addition, since the time operation rate for each time frame can be checked, trends such as reductions in the time operation rate in specific time frames, such as certain hours or days of the week, can be grasped.

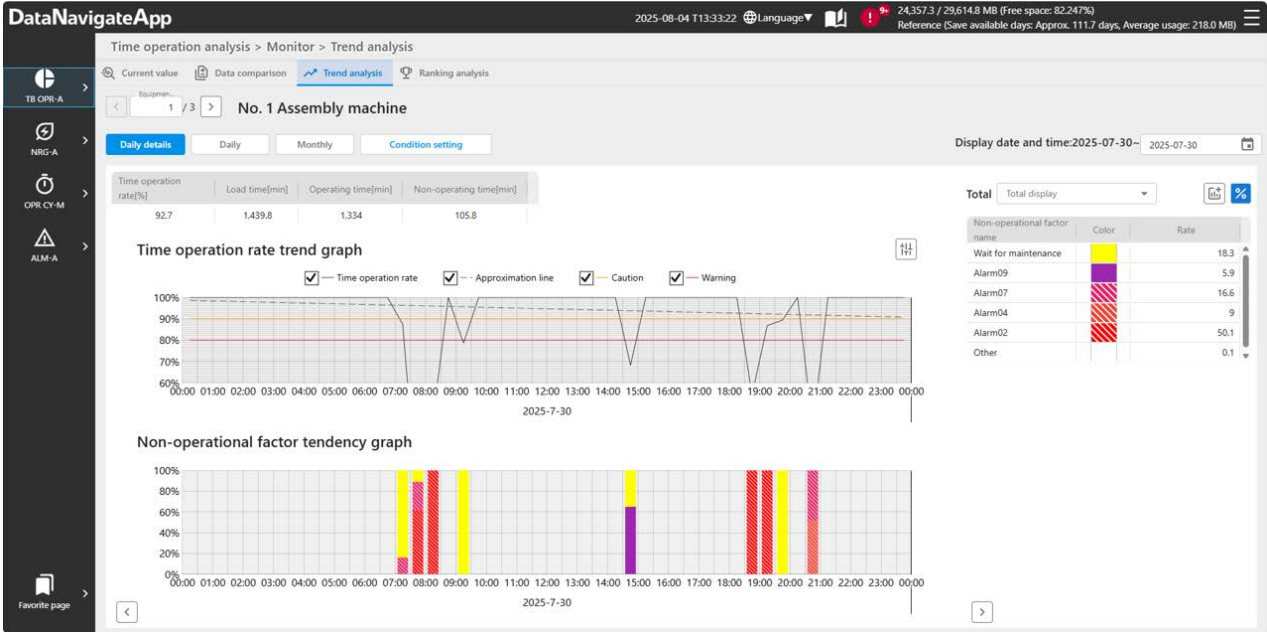

4) Equipment and factors with high countermeasure effectiveness can be checked.

In the "Ranking analysis" window, pieces of equipment with low time operation rates and non-operational factors that have occurred for a long period of time can be checked in a ranking format, making it easy to identify issues with high countermeasure effectiveness.

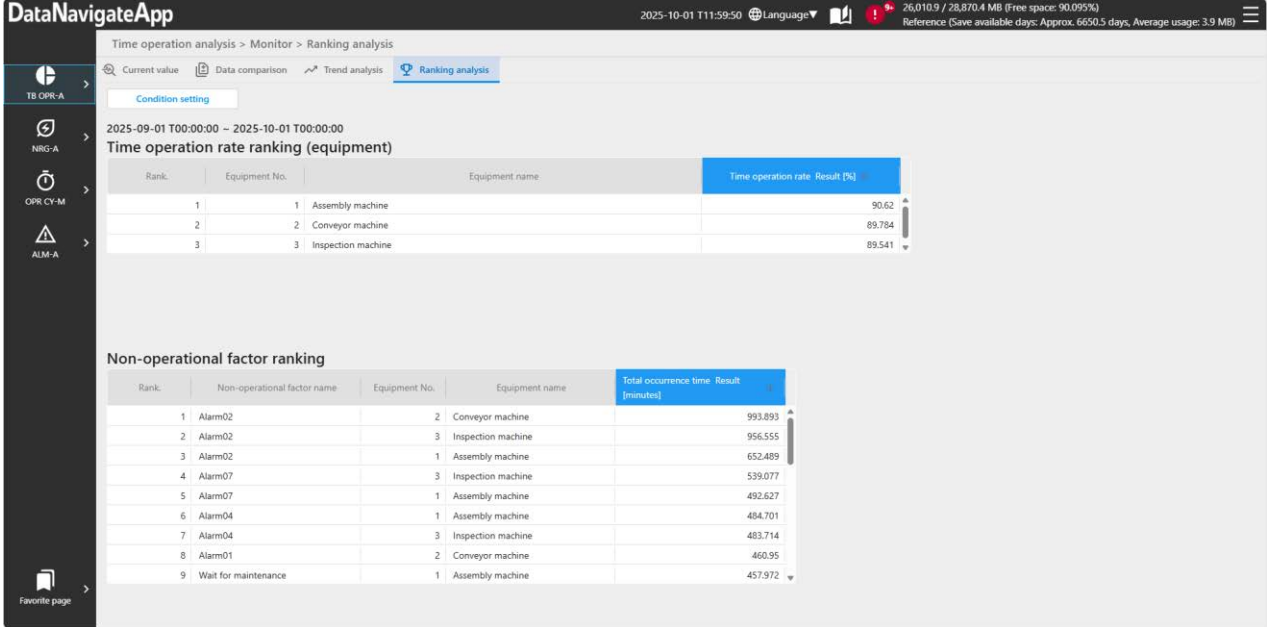

■ Application specifications

Item	Specifications			Remarks
Number of monitoring targets	Up to 33 for each equipment			An operation signal and up to 32 non-operational factor signals can be monitored.
Measurement signal/information	Signal name		Data type	-
	Operation signal		Bit *1	-
	Non-operational factor signal		Bit *1 *2	-
	Equipment running signal		Bit *1	-
Display item*3	Item		Graph type	-
	Time operation rate		Donut chart, line graph	-
	Non-operational factor information		Pareto chart	It can be switched between occurrence time and rate.
	Operation result		Gantt chart, line graph	-
Display period	Type	From	To	-
Recent data	Today	Today's date switching time	Tomorrow's date switching time	Displays data for 24 hours.
	Recent 2 days	Date switching time of 1 day ago		Displays data for 48 hours.
	Recent 3 days	Date switching time of 2 days ago		Displays data for 72 hours.
	Recent 7 days	Date switching time of 6 days ago		Displays data for 168 hours.
Total data	-	Selected date and time	Current date and time	-
Data comparison	-	Date and time selected for From	Date and time selected for To	Up to 31 days can be selected.
Trend analysis	Daily details	Date switching time of the selected date	Date switching time of the day after the selected date	Displays data for 24 hours in 30-minute intervals.
	Daily	60 days before the selected date	Selected date	Displays data for 61 days in daily intervals.
	Monthly	24 months before the selected month	Selected month	Displays data for 24 months in monthly intervals.
Ranking analysis	-	Date and time selected for From	Date and time selected for To	Up to 31 days can be selected.
Data collection target	Devices of the management CPU module			*4
Downloading/importing setting files	Supported (CSV file)			-
Alarm output	Supported (The device bit signal of the CPU is turned on.)			-

*1: It can be selected from the following devices. For a word device, specify the bit No.

X, Y, M, B, F, D, W, SM, SD, ZR

*2: For signals that alternate between ON and OFF, the status can be determined by setting the cycle (0.5 to 3.0 seconds).

*3: The information to be displayed differs depending on the window and display period.

*4: When collecting data from other equipment, use a network module or the like to collect data as necessary.

3.2. Energy Analysis App

This application visualizes the energy consumption of equipment such as power and flow of compressed air, which can be utilized for analyzing unnecessary power usage of the equipment.

1) Recent energy consumption and energy intensity of equipment can be checked.

In the "Current value" window, the recent (up to seven days) energy consumption and energy intensity of each equipment can be checked in real time. In addition to energy consumption, CO2 emissions and production costs can be checked by converting energy consumption into them.

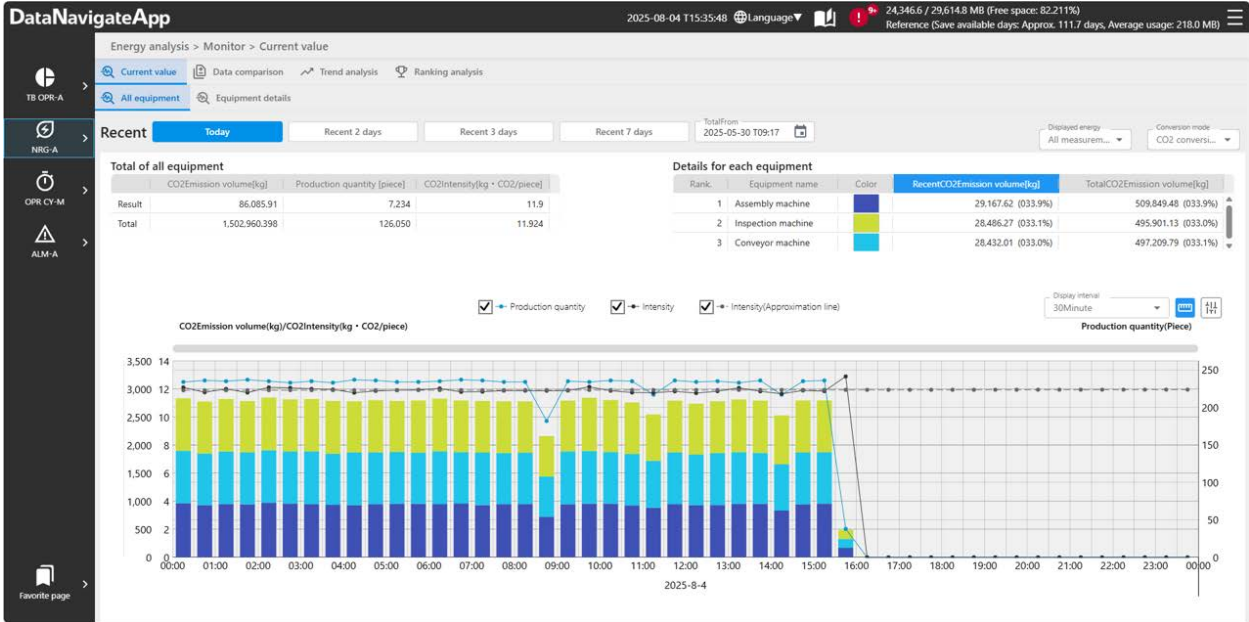

2) Issues causing unnecessary energy consumption can be analyzed.

In the "Data comparison" window, the data under different conditions (such as the equipment, period, and time frame) can be displayed for comparison. For example, waste can be analyzed and improvement effects can be checked by converting the amount of energy consumed while the equipment was not operating into costs or displaying the energy amount of similar but different pieces of equipment for comparison.

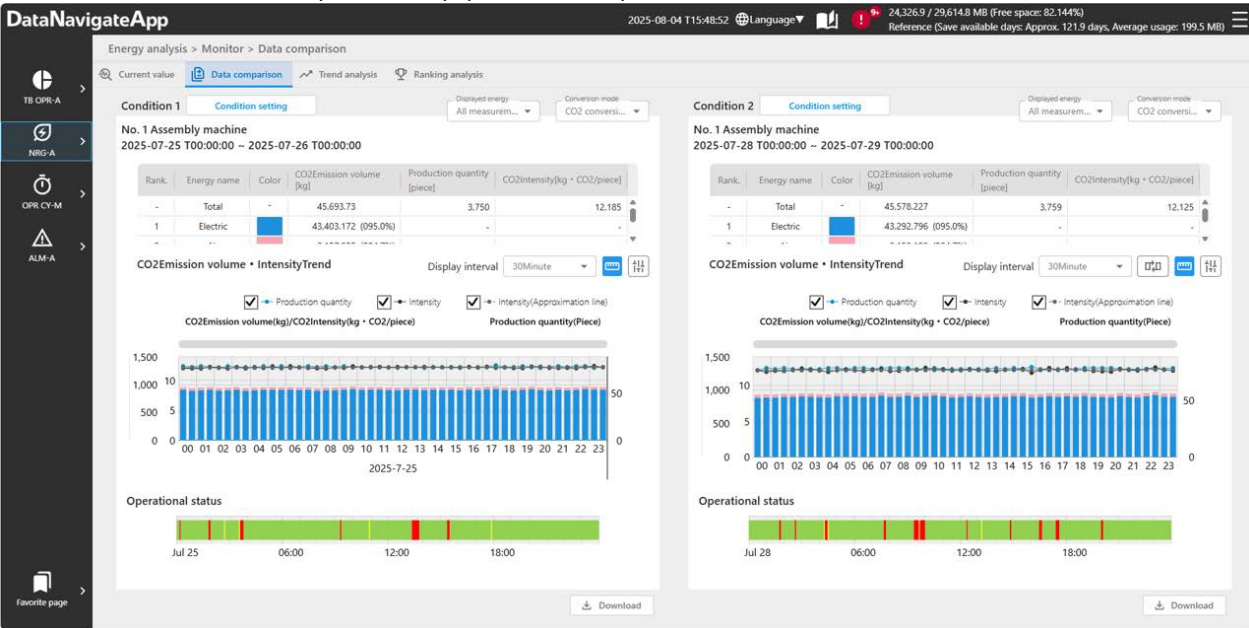

CAUTION

The information displayed as the operational status indicates the equipment operational status being analyzed in "Time-Based Operation Analysis App". If "Time-Based Operation Analysis App" is not used, the operational status will not be displayed.

3) Trends in CO2 intensity can be analyzed.

In the "Trend analysis" window, trends in CO2 intensity and production volume can be checked. Trends based on results can be grasped intuitively, which can be utilized to determine whether future countermeasures are necessary. In addition, factors contributing to increased CO2 intensity and trends of increases and decreases within a specified period can be grasped because the energy consumption relative to production quantity can be checked.

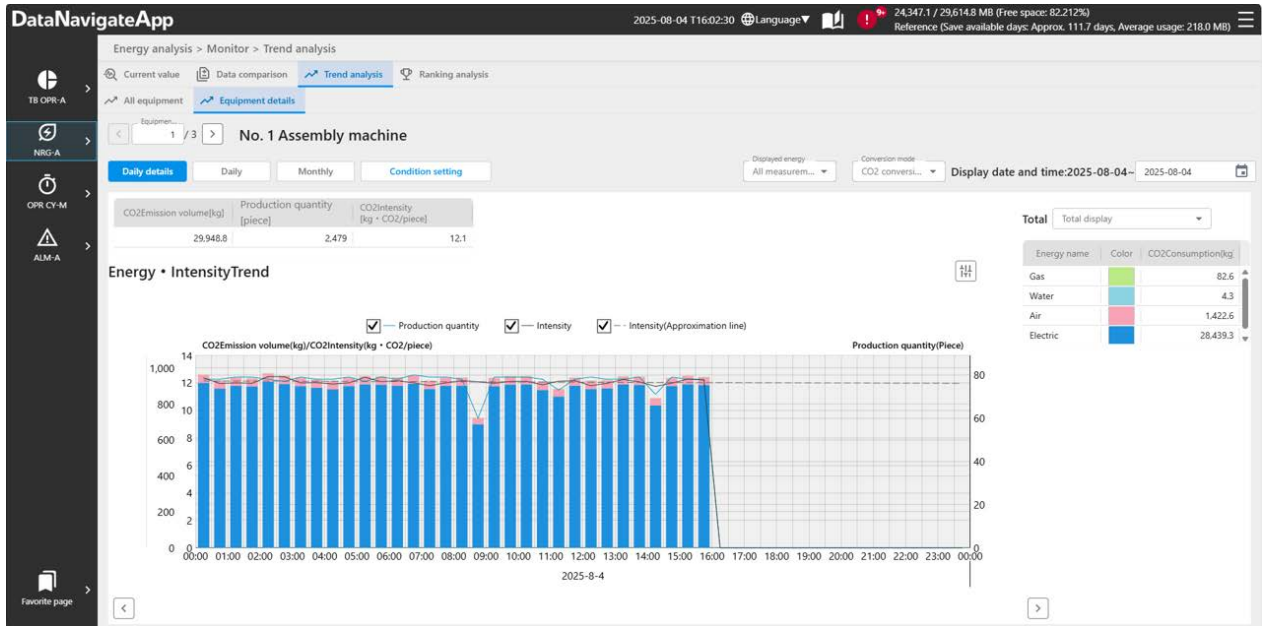

4) Equipment and factors with high countermeasure effectiveness can be checked.

In the "Ranking analysis" window, pieces of equipment with high CO2 intensity can be checked in a ranking format. By displaying such data in a ranking format, it becomes easier to identify issues with high countermeasure effectiveness.

The screenshot shows the 'Ranking analysis' window. It contains two tables. The first table is 'IntensityRanking(Equipment)' for the period 2025-08-04 T00:00:00 - 2025-08-05 T00:00:00. The second table is 'IntensityRanking(Energy)' for the same period.

Rank	Equipment No.	Equipment name	Production quantity(Piec)	CO2Emission volume[kg]	CO2Intensity(kg * CO2/piece)	EquipmentIntensity/target value	Intensity/target achievement rate	Cost[¥]	CostIntensity[¥]
1	1	Assembly machine	2,544	30,742.322	12,084	16.261	134.564	2,176,685.303	855.615
2	2	Conveyor machine	2,538	29,963.936	11,806	11.85	100.372	2,121,594.529	835.932
3	3	Inspection machine	2,544	30,017.126	11,799	11.822	100.193	2,125,363.944	835.442

Rank	Equipment No.	Equipment name	Energy name	CO2Emission volume[kg]	CO2Intensity(kg * CO2/piece)	EnergyIntensity/target value	Intensity/target achievement rate	Cost[¥]	CostIntensity[¥]
1	1	Assembly machine	Electric	29,193.138	11.475	0	0	2,066.181	26,199
2	2	Conveyor machine	Electric	28,415.25	11.196	0	0	2,011.125	25,561
3	3	Inspection machine	Electric	28,472.19	11.192	0	0	2,015.155	25,552
4	2	Conveyor machine	Air	1,459.213	0.575	0	0	103,277.616	12,622
5	1	Assembly machine	Air	1,460.033	0.574	0	0	103,335.648	12,599
6	3	Inspection machine	Air	1,455.341	0.572	0	0	103,003.576	12,559
7	2	Conveyor machine	Gas	85.044	0.034	0	0	3,422.513	16,346
8	1	Assembly machine	Gas	84.735	0.033	0	0	3,410.055	16,248
9	3	Inspection machine	Gas	85.155	0.033	0	0	3,426.968	16,328
10	1	Assembly machine	Water	4.416	0.002	0	0	3,758.6	7,387

■ Application specifications

Item	Specifications			Remarks
Number of monitoring targets	Up to 10 for each equipment			Consumption of various types of energy, such as power and compressed air, can be monitored.
Measurement signal/information	Signal name	Data type		-
	Energy usage	Word, double word, single precision real number *1		A cumulated value of energy usage. The energy consumption is calculated based on the difference in energy usage within the application.
	Production quantity	Word, double word *1		It can be selected from two patterns: measurement of "Production quantity" or "Number of non-defective products + Number of defective products".
Display item *2	Item	Graph type		-
	Energy consumption intensity	Line graph		<ul style="list-style-type: none"> • At CO2 conversion The CO2 intensity and CO2 emission volume are displayed in graphs. • At cost conversion The cost intensity and cost are displayed in graphs.
	Energy consumption	Bar graph		
	Production quantity	Line graph		-
	Operational status	Gantt chart		If "Time-Based Operation Analysis App" is not used, it will not be displayed.
Display period	Type	From	To	-
Recent data *3	Today	Today's date switching time	Tomorrow's date switching time	Displays data for 24 hours.
	Recent 2 days	Date switching time of 1 day ago		Displays data for 48 hours.
	Recent 3 days	Date switching time of 2 days ago		Displays data for 72 hours.
	Recent 7 days	Date switching time of 6 days ago		Displays data for 168 hours.
Total data	-	Selected date and time	Current date and time	-
Data comparison *3	-	Date and time selected for From	Date and time selected for To	Up to 31 days can be selected.

Item	Specifications			Remarks
Trend analysis	Daily details	Date switching time of the selected date	Date switching time of the day after the selected date	Displays data for 24 hours in 30-minute intervals.
	Daily	60 days before the selected date	Selected date	Displays data for 61 days in daily intervals.
	Monthly	24 months before the selected month	Selected month	Displays data for 24 months in monthly intervals.
Ranking analysis	-	Date and time selected for From	Date and time selected for To	Up to 31 days can be selected.
Data collection target	Devices of the management CPU module			*4
Downloading/importing setting files	Supported (CSV file)			-

*1: It can be selected from the following devices.

D, W, SD, ZR

*2: The information to be displayed differs depending on the window and display period.

*3: The display interval can be selected from 5 minutes, 30 minutes, 1 hour, and 3 hours.

*4: When collecting data from other equipment, use a network module or the like to collect data as necessary.

3.3. Operation Cycle Monitoring App

This application monitors operation time of cylinders and equipment against thresholds, which can be utilized for predictive maintenance by detecting error signs and performance degradation.

1) Recent operational status can be checked.

In the "Current value" window, the current alarm occurrence status, operation time, and statistics information of each CH can be checked in real time. Statistical values (the minimum value, average value, and maximum value), references, and thresholds for caution and warning can be grasped intuitively from charts, allowing you to determine whether signs of problems are appearing in the monitoring target cylinders and equipment.

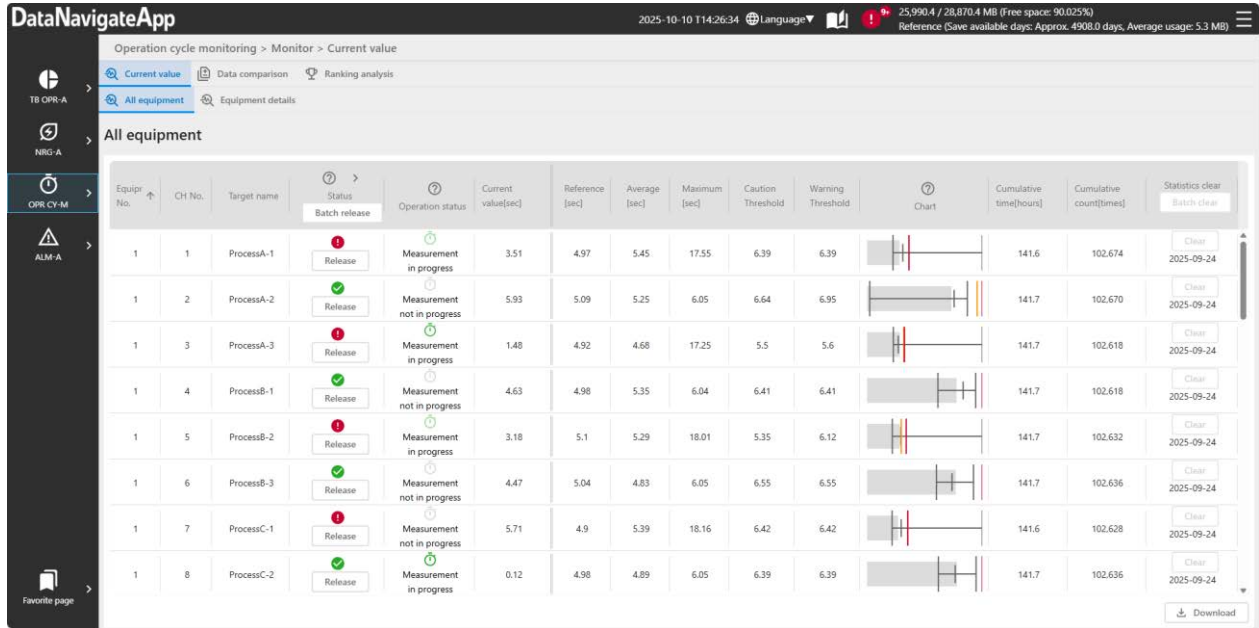

2) Trends in operation time of cylinders and equipment can be analyzed.

In the "Data comparison" window, changes in data such as operation time of cylinders and equipment can be displayed for comparison. Trends based on results can be grasped intuitively, which can be utilized to determine whether future countermeasures are necessary. In addition, data under different conditions (the equipment, CH, time frame, and product type) can be displayed for comparison. The cause of reduced operation time can be analyzed and improvement effects can be checked by displaying the data from two different dates for the same equipment and CH side by side or displaying the data from two different time frames for the same equipment and CH for comparison.



3) Equipment and factors that should be prioritized for countermeasures can be checked.

In the "Ranking analysis" window, the standard deviation rate of operation time, threshold excess count, and threshold reach rate of total operation count can be checked in a ranking format. By displaying such data in a ranking format, it becomes easier to identify equipment and issues that should be prioritized for countermeasures.

Operation cycle monitoring > Monitor > Ranking analysis

Condition setting

Rank	No.	Target name	Maximum operation time [sec]	Maximum operation time Standard deviation rate [%]	Caution excess count [times]	Warning excess count [times]	Cumulative operation time [hours]	Cumulative operation time Threshold reach rate [%]	Cumulative operation count [times]	Cumulative operation count Threshold reach rate [%]
2	3,9	Inspection machine P...	19,755	404,816	1	1	66,7	0	48,292	0
1	2,4	Conveyor machine Pr...	19,755	404,816	1	1	66,7	0	48,292	0
3	1,13	Assembly machine Pr...	19,759	398,367	2	2	119,2	0	86,388	0
4	3,5	Inspection machine P...	18,31	376,749	1	1	66,6	0	48,285	0
5	1,15	Assembly machine Pr...	18,464	375,285	2	2	119,3	0	86,474	0
6	3,1	Inspection machine P...	18,46	373,684	1	1	66,7	0	48,328	0
7	2,8	Conveyor machine Pr...	18,158	371,329	1	1	66,7	0	48,294	0
8	1,7	Assembly machine Pr...	18,162	370,653	2	2	119,3	0	86,398	0

4) Monitoring functions can be added with optional settings.

Monitoring functions can be optionally added from the "Optional setting" window. The following describes the main additional functions.

- Delay timer setting...When the set time elapses after the condition of the set device is met, threshold monitoring is enabled.
- Consecutive threshold excess count setting...An alarm is issued when the caution threshold or warning threshold is consecutively exceeded for the set number of times.
- Sensor error...An alarm is issued when the detection timing of the operation start signal and operation completion signal is abnormal.
- Variation monitoring...An alarm is issued when the recent standard deviation is excessively larger than that of the reference data.

$$[\text{Standard deviation of reference data} \times 1.36] < [\text{Standard deviation for each 30 times of operation}]$$
- Cumulative threshold setting...The preset values and thresholds for the cumulative time and cumulative count can be set. An alarm is issued when any of the thresholds is exceeded.

Operation cycle monitoring > Setting > Optional setting

Monitoring details

No.	Equipment name	Download setting	Report setting
1	Assembly machine	X	-
2	Conveyor machine	Y	-
3	Inspection machine	Y	-

Monitoring details/Setting

Equipment name: Assembly machine

ThresholdSetting

CH No.	Target name	Cumulative time(thour)	Cumulative count(times)	Cumulative time threshold(times)	Cumulative count threshold(times)	Line clear
1	ProcessA-1	141	102760	0	0	X
2	ProcessA-2	141	102774	0	0	X
3	ProcessA-3	141	102722	0	0	X
4	ProcessB-1	141	102722	0	0	X
5	ProcessB-2	141	102734	0	0	X
6	ProcessB-3	141	102738	0	0	X
7	ProcessC-1	141	102730	0	0	X
8	ProcessC-2	141	102740	0	0	X

■ Application specifications

Item	Specifications			Remarks	
Number of monitoring targets	Each equipment: Up to 200 All equipment: Up to 400			-	
Measurement signal/information	Signal name		Data type	-	
	Measurement start signal		Bit *1		
	Measurement end signal		Bit *1		
Display period	Type	From	To	-	
Current value	-	Clear date	Current date and time	-	
	Data comparison *2	Today	Today's date switching time	Tomorrow's date switching time	Displays data for 24 hours.
		Recent 2 days	Date switching time of 1 day ago		Displays data for 48 hours.
		Recent 3 days	Date switching time of 2 days ago		Displays data for 72 hours.
		Recent 7 days	Date switching time of 6 days ago		Displays data for 168 hours.
Ranking analysis	-	Clear date	Current date and time	Displays data for 168 hours.	
Monitoring item	Operation time error			-	
	Total operation time error			Enabled in the optional setting.	
	Cumulative operation count			Enabled in the optional setting.	
	Variation error			Enabled in the optional setting.	
	Sensor error			Enabled in the optional setting.	
Data collection target	Devices of the management CPU module			*3	
Downloading/importing setting files	Supported (CSV file)			-	
Alarm output	Supported (The device bit signal of the CPU is turned on.)			-	

*1: It can be selected from the following devices. For a word device, specify the bit No.

X, Y, M, B, F, D, W, SM, SD, ZR

*2: The average value and maximum value per 5 minutes are displayed.

*3: When collecting data from other equipment, use a network module or the like to collect data as necessary.

3.4. Alarm Analysis App

This application visualizes the alarm occurrence status of equipment (the number of occurrences and time) and allows you to tag alarms with information from desired perspectives such as processes and causes. This can help you grasp errors with high occurrence frequency or significant impact from each perspective.

1) Recent alarm information of equipment can be checked.

In the "Current value" window, the recent (up to seven days) alarm occurrence status (such as the number of occurrences and recovery time) for each equipment can be displayed. The total alarm occurrence status from the specified date can be monitored at the same time, allowing you to check whether the alarm occurrence status has changed recently.

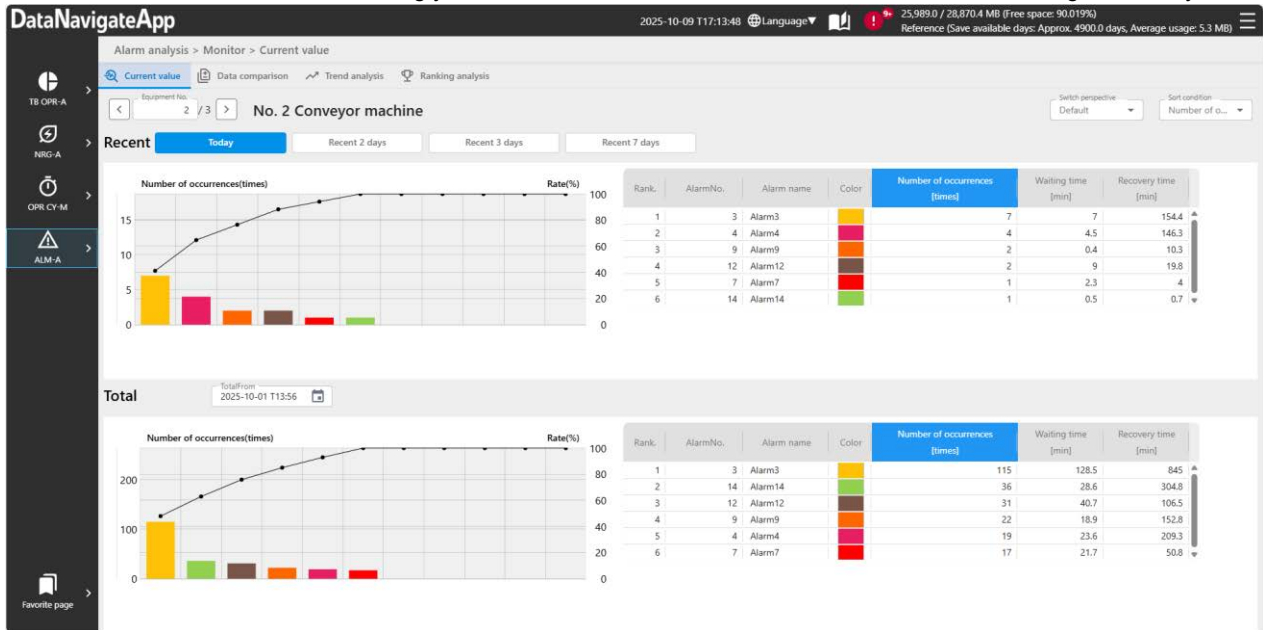

2) Alarms with high countermeasure effectiveness can be analyzed.

In the "Data comparison" window, the alarm information (the number of alarm occurrences, waiting time, recovery time, and rate) under different conditions (such as the equipment, time frame, and product type) can be displayed for comparison. For example, alarms with high improvement effects can be analyzed by displaying the data from two different dates for the same equipment side by side or displaying the data from two different time frames within the same period for the same equipment for comparison.

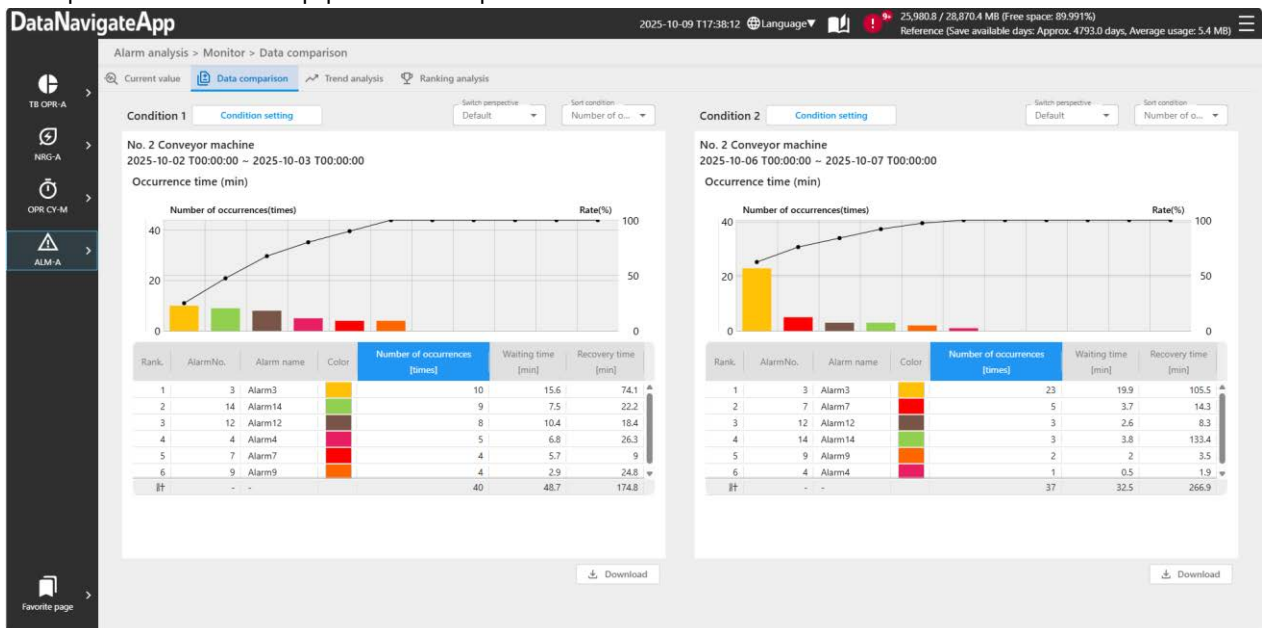

3) Trends in the alarm occurrence information can be analyzed.

In the "Trend analysis" window, trends such as changes in the number of alarm occurrences and occurrence time can be checked. Trends based on results can be grasped intuitively, which can be utilized to determine whether future countermeasures are necessary. In addition, since the breakdown of alarm information can be checked, trends such as frequent occurrences during specific time frames, such as certain hours or days of the week, can also be grasped.

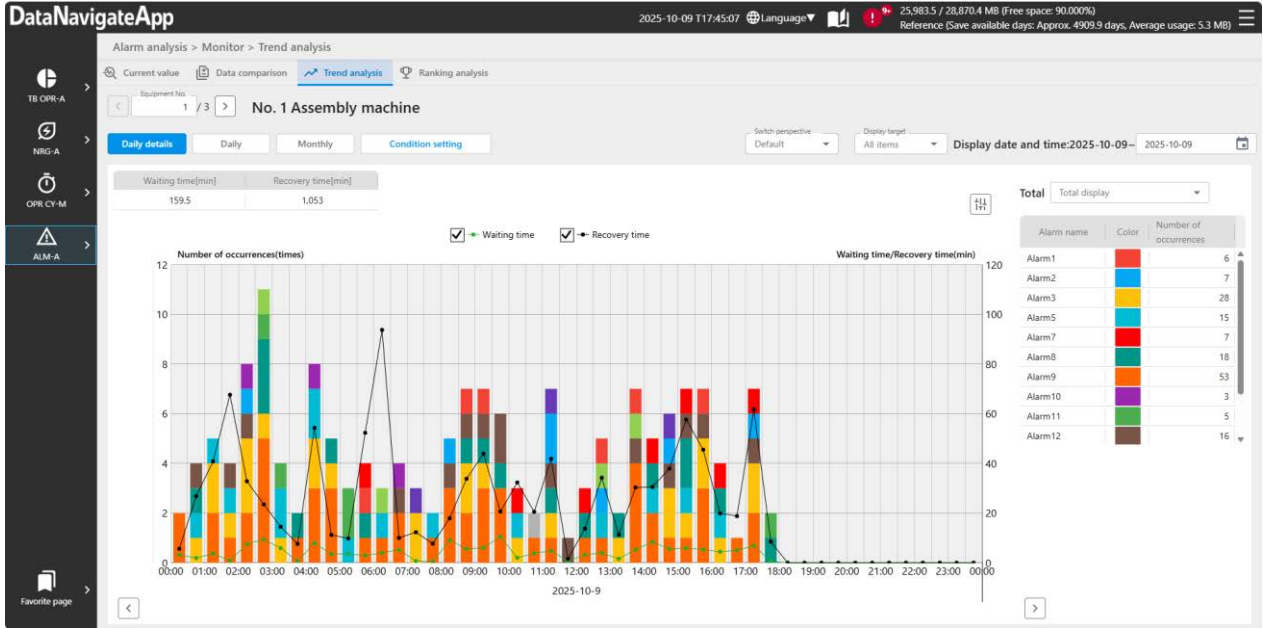

4) Equipment and factors with high countermeasure effectiveness can be checked.

In the "Ranking analysis" window, equipment with a high number of alarm occurrences and alarms that have been occurring for a long period of time can be checked in a ranking format. By displaying such data in a ranking format, it becomes easier to identify issues with high countermeasure effectiveness.

The screenshot shows the 'Ranking analysis' window. It displays a table of alarm occurrences ranked by the number of occurrences. The data is as follows:

Rank	Equipment No.	AlarmNo.	Alarm name	Number of occurrences	Cumulative recovery time [min]	Maximum recovery time [min]	Average recovery time [min]	Cumulative waiting time [min]	Maximum waiting time [min]	Average waiting time [min]
1	1	9	Alarm9	53	306.4	28.5	5.8	61.9	5	1.2
2	1	3	Alarm3	28	213	19.7	7.6	24.2	2.3	0.9
3	1	8	Alarm8	18	88.5	19.2	4.9	14.2	2.1	0.8
4	1	12	Alarm12	16	93.9	17.1	5.9	10.2	2	0.6
5	1	5	Alarm5	15	123.9	33	8.3	14.4	3.4	1
8	2	3	Alarm3	7	154.4	138.9	22.1	7	1.6	1
7	1	7	Alarm7	7	63.8	18.1	9.1	5.8	1.9	0.8
6	1	2	Alarm2	7	49.2	16.2	7	12.2	2.9	1.7
10	3	1	Alarm1	6	70	56.4	11.7	13.5	4.5	2.2
9	1	1	Alarm1	6	44.5	13.7	7.4	3.6	1	0.6
11	1	11	Alarm11	5	10.3	4.5	2.1	5.5	2	1.1
14	3	8	Alarm8	4	15.1	5.7	3.8	1.9	1	0.5
13	2	4	Alarm4	4	146.3	133.5	36.6	4.5	3.1	1.1
12	1	14	Alarm14	4	38.6	32.1	9.6	2.4	1	0.6
16	1	13	Alarm13	3	4.1	1.9	1.4	0.6	0.5	0.2

■ Application specifications

Item	Specifications			Remarks
Number of monitoring targets	Each equipment: Up to 500 All equipment: Up to 1000			-
Measurement signal/information *1	Signal name	Data type		-
	Alarm code	Word unsigned *2		Set a value to determine that an alarm has occurred.
	Alarm signal	Bit *3		-
	Action start signal	Bit *3		Use it only when measuring the waiting time.
	Recovery completion signal	Bit *3		-
Display item *4	Item	Graph type		
	Alarm information	Pareto chart		It can be switched between the number of occurrences, waiting time, and recovery time.
Display period	Type	From	To	-
Recent data	Today	Today's date switching time	Tomorrow's date switching time	Displays data for 24 hours.
	Recent 2 days	Date switching time of 1 day ago		Displays data for 48 hours.
	Recent 3 days	Date switching time of 2 days ago		Displays data for 72 hours.
	Recent 7 days	Date switching time of 6 days ago		Displays data for 168 hours.
Total data	-	Selected date and time	Current date and time	
Data comparison	-	Date and time selected for From	Date and time selected for To	Up to 31 days can be selected.
Trend analysis	Daily details	Date switching time of the selected date	Date switching time of the day after the selected date	Displays data for 24 hours in 30-minute intervals.
	Daily	60 days before the selected date	Selected date	Displays data for 61 days in daily intervals.
	Monthly	24 months before the selected month	Selected month	Displays data for 24 months in monthly intervals.
Ranking analysis	-	Date and time selected for From	Date and time selected for To	Up to 31 days can be selected.
User perspective	Up to 4			Any perspectives can be set for analyzing alarms.
Tagging	50 for each user perspective			Any tags can be set for analyzing alarms.
Data collection target	Devices of the management CPU module			*5
Downloading/importing setting files	Supported (CSV file)			-

*1: Select whether to use either or both of the alarm code and alarm signal.

*2: It can be selected from the following devices.

D, W, SD, ZR

*3: It can be selected from the following devices. For a word device, specify the bit No.

X, Y, M, B, F, D, W, SM, SD, ZR

*4: The information to be displayed differs depending on the window, display period, and selected conversion mode.

*5: When collecting data from other equipment, use a network module or the like to collect data as necessary.

4. STARTUP PROCEDURE

Install DataNavigateApp to an SD memory card, and insert it into the C intelligent function module.
This chapter shows the procedure from starting up this application to accessing it with a browser.

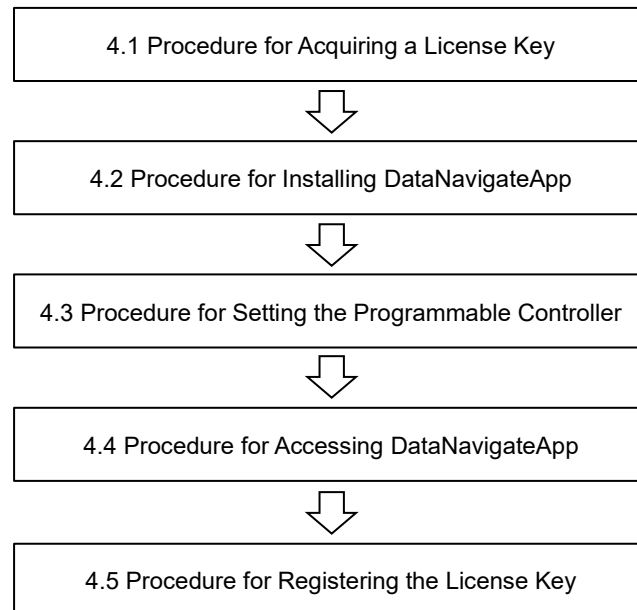

4.1. Procedure for Acquiring a License Key

To use this application, apply for and acquire a license key.

Acquire a license key from "DataNavigateApp License Key Request form" in the MITSUBISHI ELECTRIC Factory Automation website. After the application, the license key file (datanavi_license[16-character manufacturing information].lic) will be sent as an e-mail attachment.

The information required for the application is as follows.

Information	Item	Remarks
Application information	Product name	Refer to the license agreement.
	Product model	
	Product ID	
Hardware information	Module name	Refer to "Checking Production Information and Firmware Version" in "MELSEC iQ-R Module Configuration Manual".
	Manufacturing information (Serial No.)	

CAUTION

Do not change the file name of the obtained license key file.

Doing so disables authentication.

4.2. Procedure for Installing DataNavigateApp

Write the image file for installing DataNavigateApp, which is required to use this application, to the SD memory card. The following shows the procedure.

1. Access the following URL and download the free software "DD for Windows" to the personal computer, and unzip the file.

 <https://www.si-linux.co.jp/techinfo/index.php?DD%20for%20Windows#s74c46f6>

Download "Ver.0.9.9.8".

CAUTION

When writing the image file for installing DataNavigateApp to the SD memory card, use "DD for Windows" instead of using Explorer.

The installation cannot be properly performed without using "DD for Windows".

2. Insert the SD memory card into the personal computer, and if necessary data is stored on it, back it up to another location (such as the hard disk of the personal computer or an external drive) in advance.
3. Right-click the exe file "DDWin" in the folder unzipped in step 1, and select "Run as administrator".

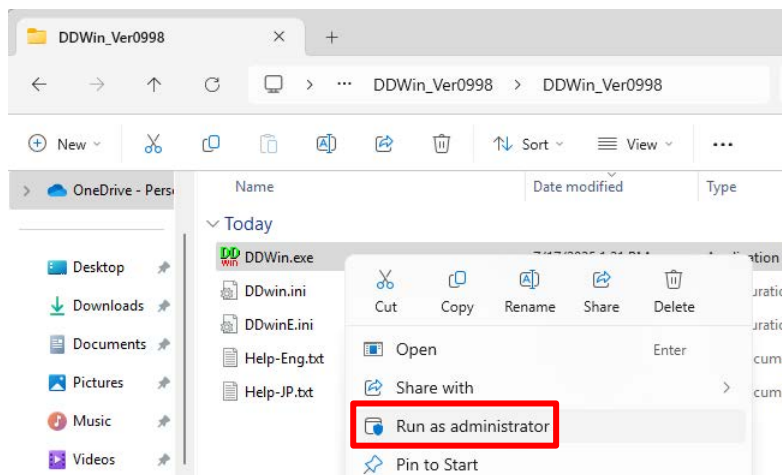

4. When "DD for Windows" is displayed on the screen, select the following items.
 - Click "Choose file" and select the image file for installing DataNavigateApp.
 - Click "Choose disk" and select the drive where the SD memory card is inserted.



5. With the "<<Restore<<" button, write the image file for installing DataNavigateApp to the SD memory card.

CAUTION

Do not perform the following operations while data is being written. The SD memory card may be damaged and become unusable.

- **Removing the SD memory card**
- **Making the personal computer sleep**

Writing data to the SD memory card takes approximately 15 minutes. Check the sleep setting of the personal computer or take sufficient precautions to prevent it from going to sleep.

6. After writing is completed, remove the SD memory card from the personal computer.

CAUTION

A dialog prompting you to format the disk appears. **Select "Cancel"**.

If "Format disk" is selected, the written image file for installing DataNavigateApp will be deleted.

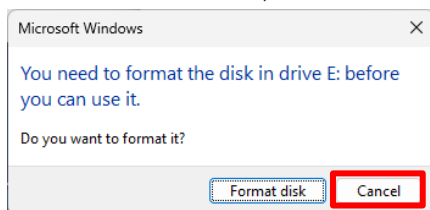

4.3. Procedure for Setting the Programmable Controller

Write project data of GX Works3, which is required to use this application, to the programmable controller.

This section provides procedures for the following two cases.

- (1) When adding a new programmable controller
- (2) When adding a C intelligent function module to an existing device configuration

(1) When adding a new programmable controller

(a) Mounting modules

1. Mount the CPU module, power supply module, and C intelligent function module on the base unit as follows.
(Mount the C intelligent function module on a desired slot No.)

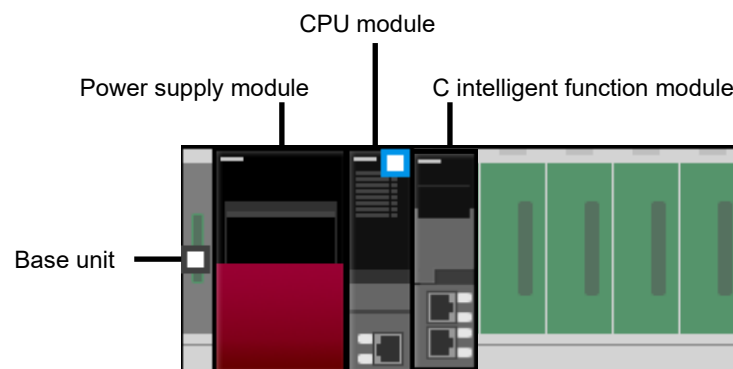

2. Insert the SD memory card in which DataNavigateApp is installed according to the procedure described in "4.2 Procedure for Installing DataNavigateApp" into the C intelligent function module.

 TIPS

Enabling the writing lock of the SD memory card after installing DataNavigateApp to it will not affect the operation of DataNavigateApp.

3. Power off and on the programmable controller. Wait until the "RUN" and "CARD RDY" LEDs of the C intelligent function module turn on in green.
4. Power off and on the programmable controller again. Wait until the "USER" LED of the C intelligent function module turns on in green.

- (b) Preparing project data of GX Works3
 1. Prepare the project data of GX Works3 to be used in conjunction with DataNavigateApp.
 2. In the Navigation window of GX Works3, double-click [Parameter], right-click [Module Information] , and select "Add New Module".

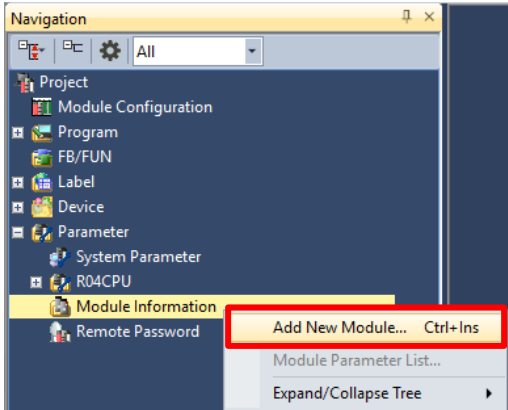

- 3. To add a C intelligent function module (RD55UP12-V), select the following items and click [OK].

Item	Description
Module Type	Information Module
Module Name	RD55UP12-V
Mounting Slot No.	Slot No. of the actual base unit on which "RD55UP12-V" is mounted
Start I/O No. Specification	Not Set

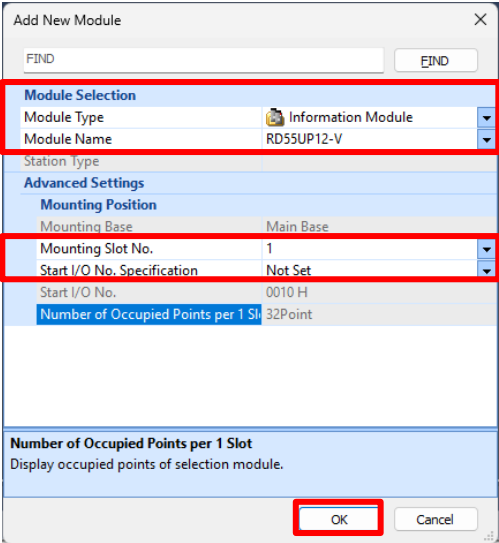

- 4. Double-click the C intelligent function module (RD55UP12-V) added to the Navigation window to open the module parameter window.

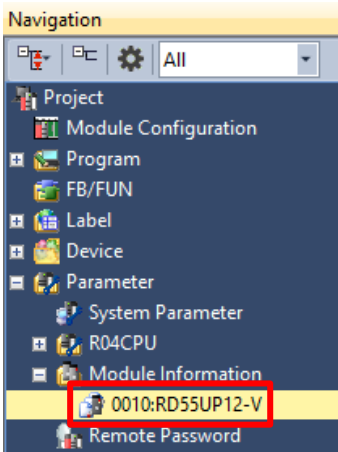

- 5. Set the IP address of "RD55UP12-V" in the basic setting. Use CH1 for the port CH. Set a unique value that does not conflict with any other IP addresses.

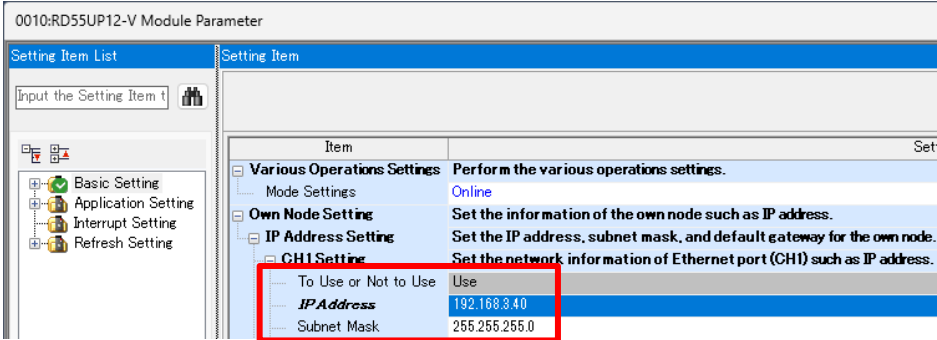

(c) Writing the project data of GX Works3

1. Select [Online] - [Write to PLC] from the menu of GX Works3.



2. The "Online Data Operation" window is displayed. Select the items to be written, and click [Execute] to write the project data to the programmable controller.
(With sufficient memory capacity, it is acceptable to select all items as the items to be written.)

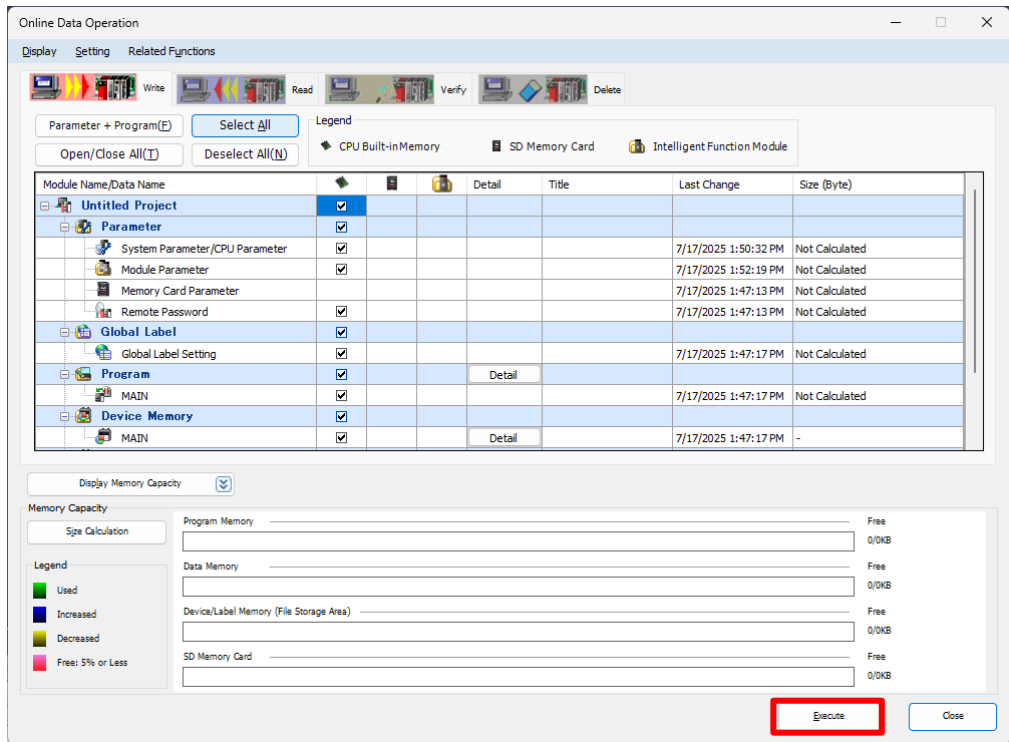

3. Power off and on the programmable controller.

- (2) When adding a C intelligent function module to an existing device configuration
- (a) Mounting the module
 1. Mount the C intelligent function module on the base unit.
 2. Insert the SD memory card in which DataNavigateApp is installed according to the procedure described in "4.2" into the mounted C intelligent function module.
 3. The subsequent steps are the same as step 3 and onward in "4.3(1)(a)". Refer to step 3 and onward in "4.3(1)(a)".

 - (b) Preparing project data of GX Works3
 1. Prepare the project data of GX Works3 in use.
 2. The subsequent steps are the same as step 2 and onward in "4.3(1)(b)". Refer to step 2 and onward in "4.3(1)(b)".

 - (c) Writing the project data of GX Works3

The steps are the same as those in "4.3(1)(c)". Refer to "4.3(1)(c)".

4.4. Procedure for Accessing DataNavigateApp

Configure the communication setting to access DataNavigateApp from a browser, which is required to use this application.

This section provides procedures for the following three patterns of configurations for connecting the C intelligent function module to the personal computer.

- (1) When connecting directly (or via an access point)
- (2) When connecting using the routing function of the router
- (3) When connecting using the NAT/NAPT function of the router

In this chapter, only the settings specific to DataNavigateApp are explained. For details and methods of the router setting, check the instruction manual of your router.

- (1) When connecting directly (or via an access point)
The following configuration is used as an example.

[Connection configuration example]

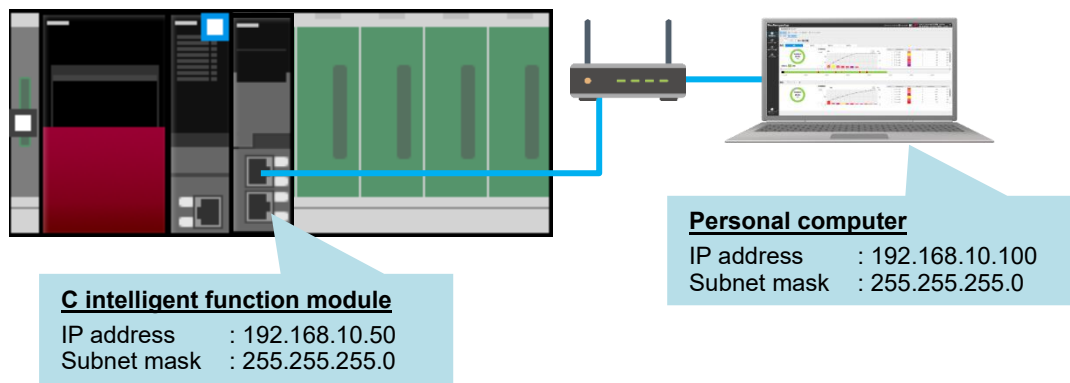

1. Connect the LAN port of CH1 on the C intelligent function module and the personal computer.
2. Open a web browser and enter "http://IP address of the C intelligent function module:3000" (example: http://192.168.10.50:3000) to access DataNavigateApp.

When accessed successfully, the following window is displayed.

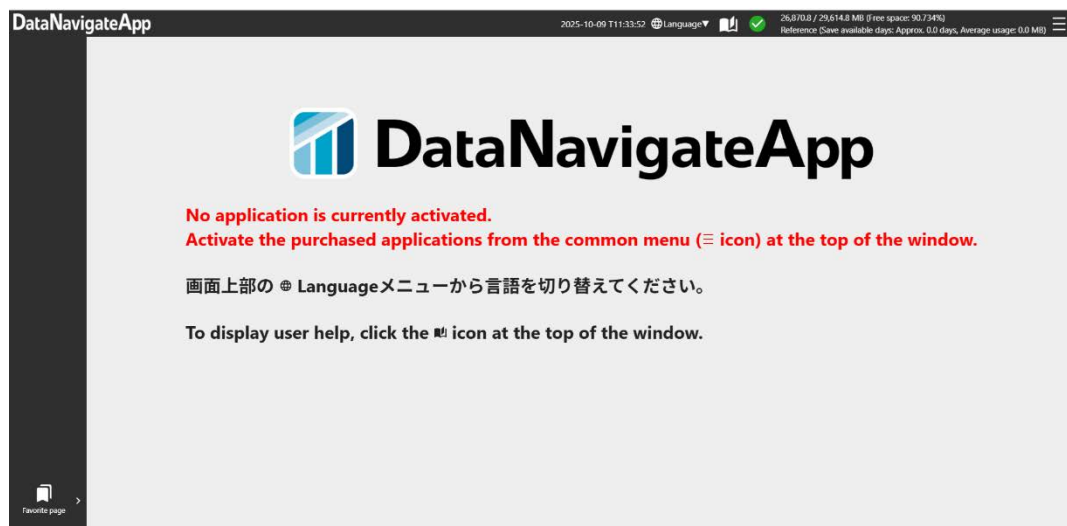

POINT

Immediately after the programmable controller is powered on, DataNavigateApp may not be accessed because the web server is not started yet. **If DataNavigateApp cannot be accessed, access it again after 2 to 3 minutes.**

- (2) When connecting using the routing function of the router
The following configuration is used as an example.

[Connection configuration example]

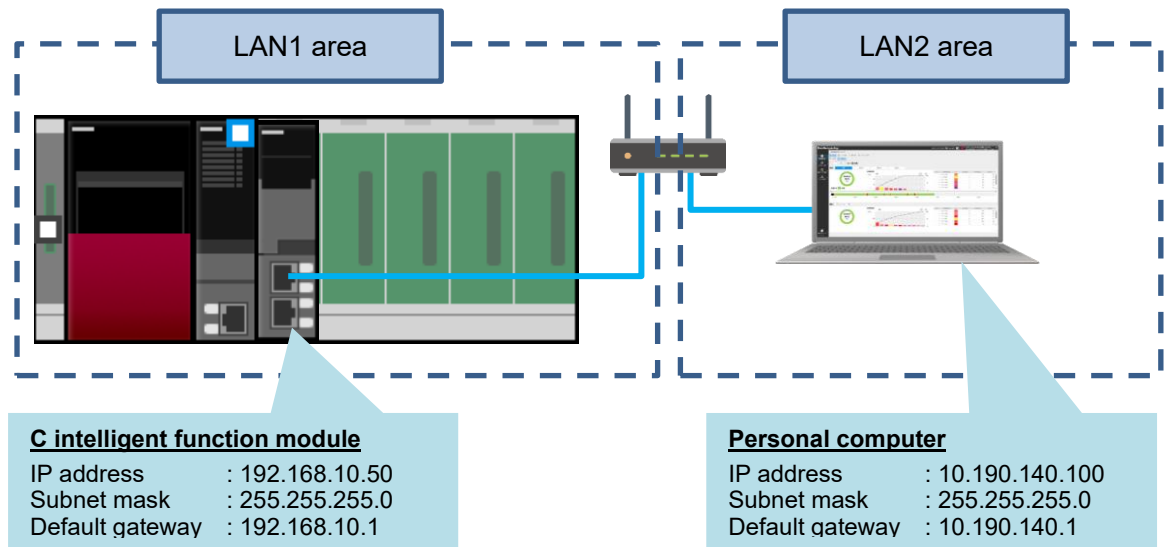

1. Connect the LAN port of CH1 on the C intelligent function module and the router.
2. Connect the personal computer and the router.
3. Open a web browser and enter "http://IP address of the C intelligent function module:3000" (example: http://192.168.10.50:3000) to access DataNavigateApp.

When accessed successfully, the following window is displayed.

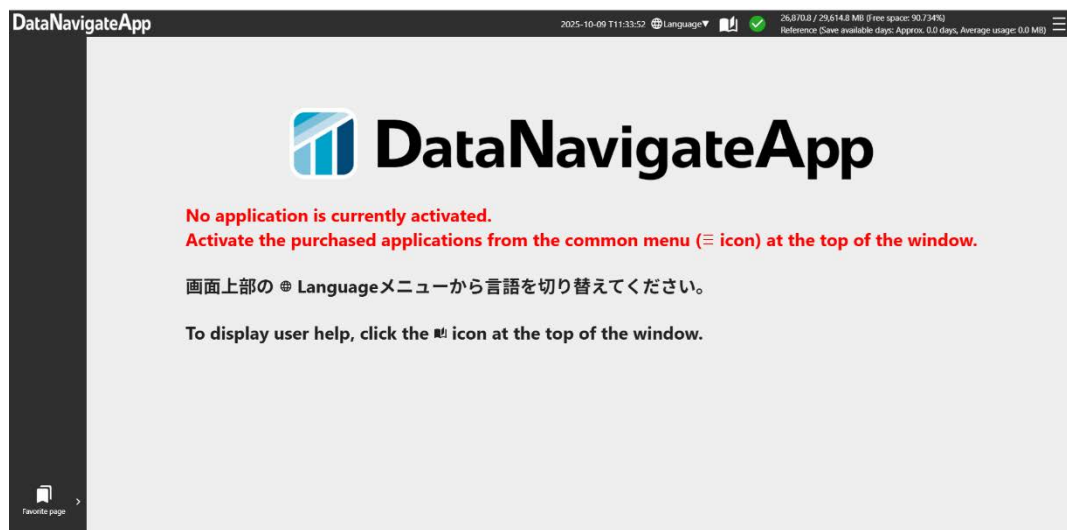

POINT

Immediately after the programmable controller is powered on, DataNavigateApp may not be accessed because the web server is not started yet. **If DataNavigateApp cannot be accessed, access it again after 2 to 3 minutes.**

(3) When connecting using the NAT/NAPT function of the router
If "the IP address specified in the web browser" and "the IP address of the C intelligent function module" differ, DataNavigateApp cannot be accessed in the initial state. Thus, when using the NAT/NAPT function, register IP addresses to be allowed to connect to DataNavigateApp in advance. This section provides procedures for the following two registration methods.

- (a) When directly connecting and registering an IP address
- (b) When connecting using the NAT/NAPT function of the router and registering an IP address

- (a) When directly connecting and registering an IP address
The following configuration is used as an example.

[Connection configuration example]
< When registering the IP address allowed for connection >

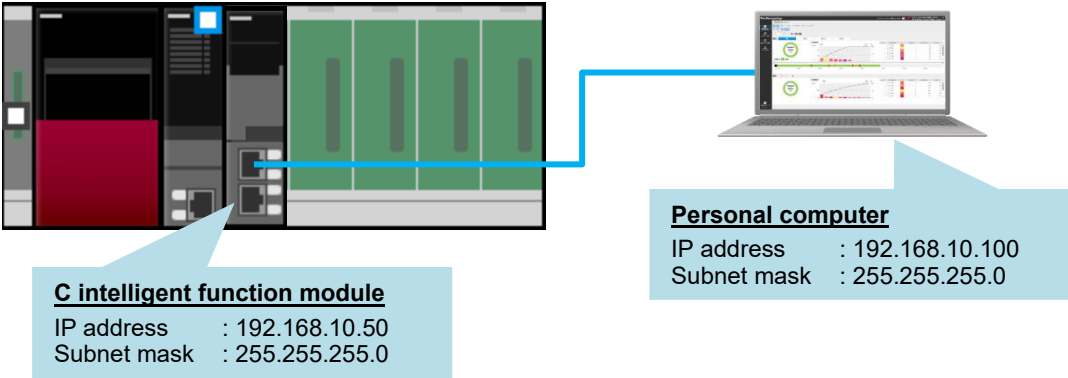

< When operating (connected using the NAT/NAPT function) >

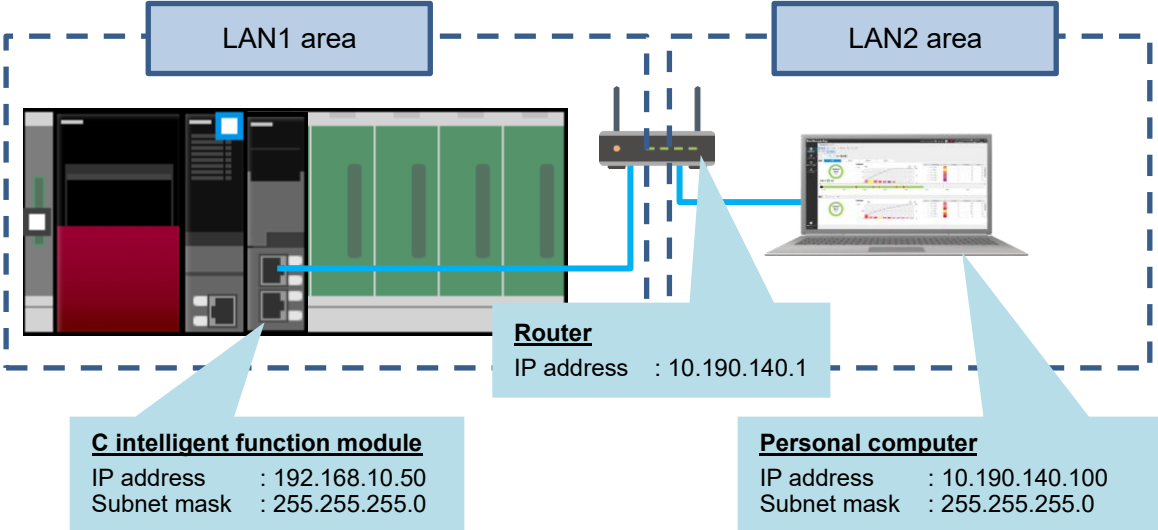

■ Registration method

1. Connect the LAN port of CH1 on the C intelligent function module and the personal computer.
2. Using the support tool, register the IP address of the router (example: 10.190.140.1) as an external IP address of the C intelligent function module allowed for connection.
For the registration method of external IP addresses, refer to "6.1.2 Registration of external IP addresses".
3. Restart the programmable controller to apply the setting of the support tool.

■ Connection method

1. Open the router settings and set static IP masquerade for the following ports.

Identification No.	Internal address	Port No.
1	IP address of the C intelligent function module (Example: 192.168.10.50)	3000
2	IP address of the C intelligent function module (Example: 192.168.10.50)	8080

2. Open a web browser and enter "http://IP address of the router in the LAN area on the personal computer side:3000" (example: http://10.190.140.1:3000) to access DataNavigateApp.
When accessed successfully, the following window is displayed.

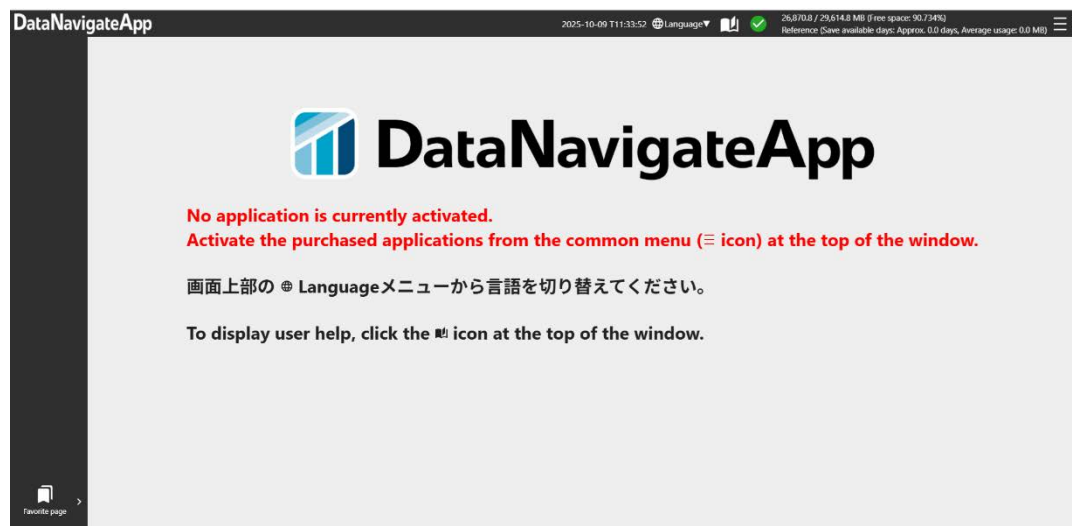

POINT

Immediately after the programmable controller is powered on, DataNavigateApp may not be accessed because the web server is not started yet. **If DataNavigateApp cannot be accessed, access it again after 2 to 3 minutes.**

- (b) When connecting using the NAT/NAPT function of the router and registering an IP address
The following configuration is used as an example.

[Connection configuration example]

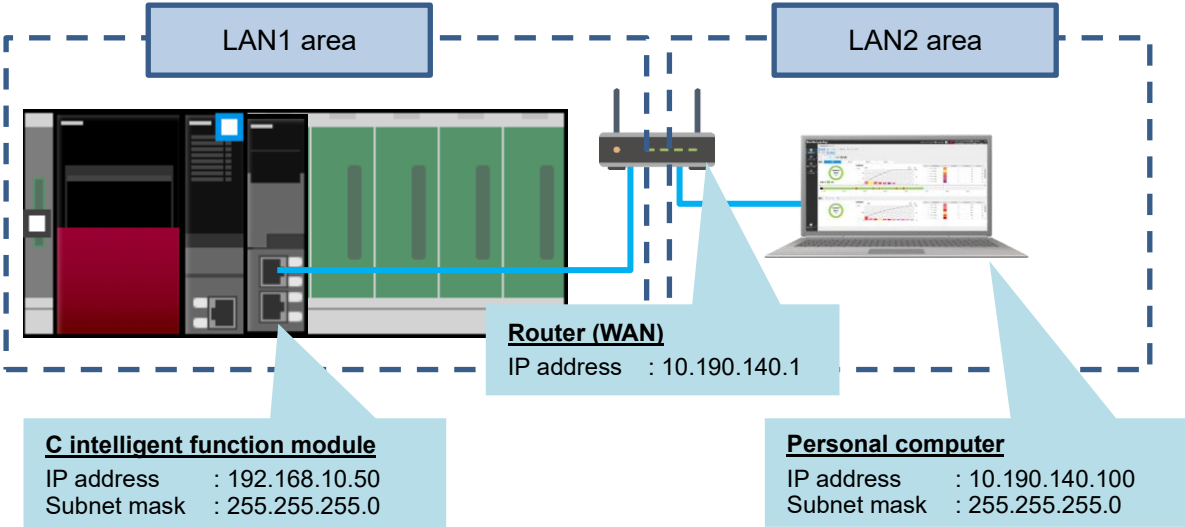

■ Registration method

1. Connect the LAN port of CH1 on the C intelligent function module and the router.
2. Connect the personal computer and the router.
3. Open the router settings and set static IP masquerade for the following ports.

Identification No.	Internal address	Port No.
1	IP address of the C intelligent function module (Example: 192.168.10.50)	3000
2	IP address of the C intelligent function module (Example: 192.168.10.50)	8080
3	IP address of the C intelligent function module (Example: 192.168.10.50)	52122

4. Using the support tool, register the IP address of the router to be used (example: 10.190.140.1) as an external IP address of the C intelligent function module allowed for connection.
For the registration method of external IP addresses, refer to "6.1.2 Registration of external IP addresses".
5. Restart the programmable controller to apply the setting of the support tool.

TIPS

Port No. 52122 will not be used after the registration to the C intelligent function module with the support tool. **Delete the setting** as needed.

■ Connection method

1. Open a web browser and enter "http://IP address of the router in the LAN area on the personal computer side:3000" (example: http://10.190.140.1:3000) to access DataNavigateApp.

When accessed successfully, the following window is displayed.

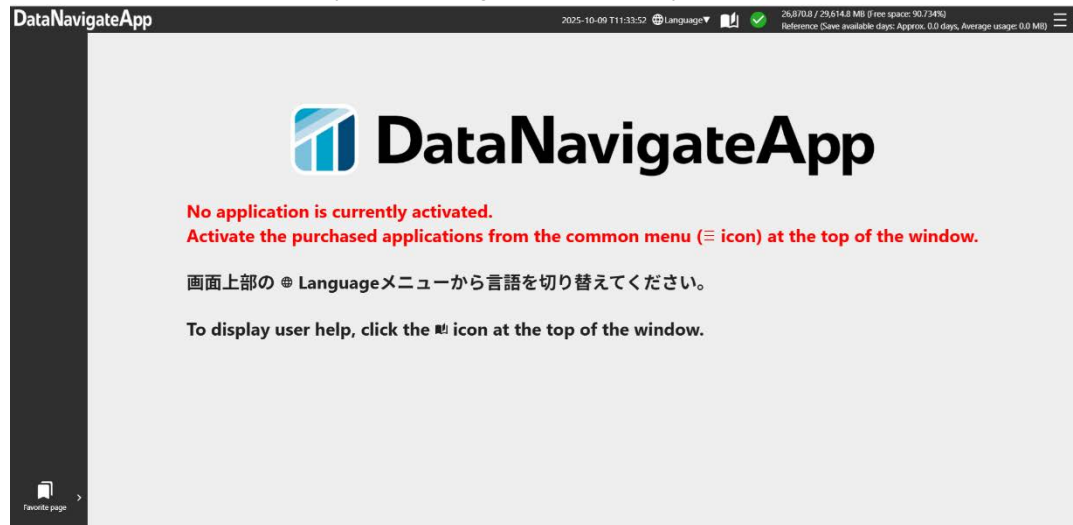

POINT

Immediately after the programmable controller is powered on, DataNavigateApp may not be accessed because the web server is not started yet. **If DataNavigateApp cannot be accessed, access it again after 2 to 3 minutes.**

4.5. Procedure for Registering the License Key

Register the license key, which is required to use this application.

■ Registration method on the application

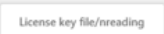
1. Click the  button on the top right of the application and select [Activation] to display the activation window.
2. Click  to read the license key file acquired in "4.1 Procedure for Acquiring a License Key".

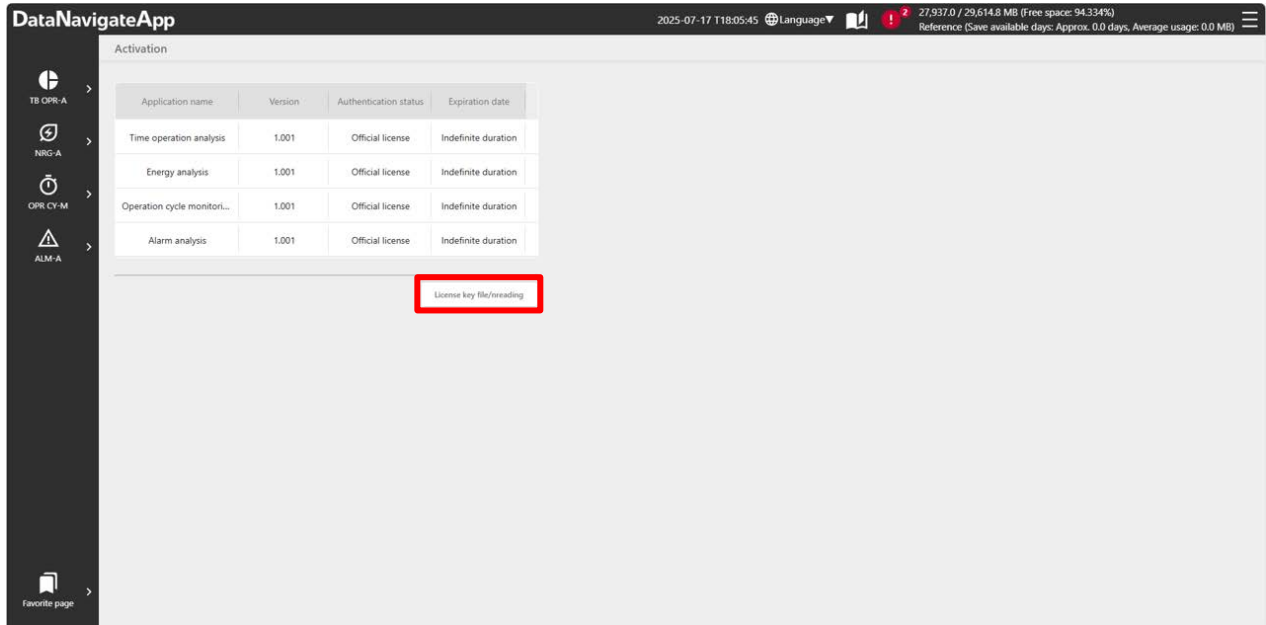

4.6. Troubleshooting at Startup

If DataNavigateApp does not start up correctly, check the relevant case in this section and perform troubleshooting.

- When the image file for installing DataNavigateApp cannot be written properly to the SD memory card

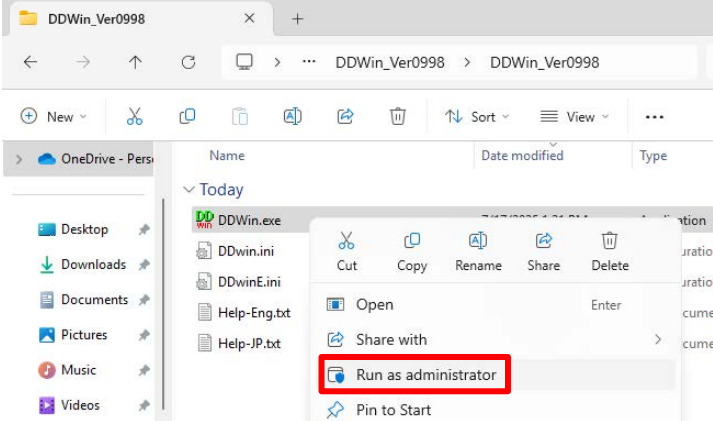
Case	Action
<p>The writing destination drive cannot be selected.</p>	<p>Right-click "DD for Windows" and select "Run as administrator" to start it.</p> 
<p>An error stating that the memory is corrupted occurs while the file is being written.</p>	<p><u>The personal computer may have gone to sleep while the file was being written to the SD memory card.</u></p> <p>Check the sleep setting of the personal computer, and take sufficient precautions to prevent it from going to sleep.</p> <p>Writing data to the SD memory card takes approximately 15 minutes.</p>

- When the ERR LED of the C intelligent function module turns on
Check the error code using the following steps, and perform the action according to the situation.

1. Select [Diagnostics] - [System Monitor] from the menu of GX Works3.

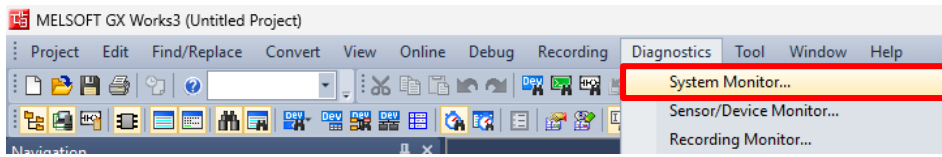

2. Double-click the module model name [RD55UP12-V] on the displayed "System Monitor" window.

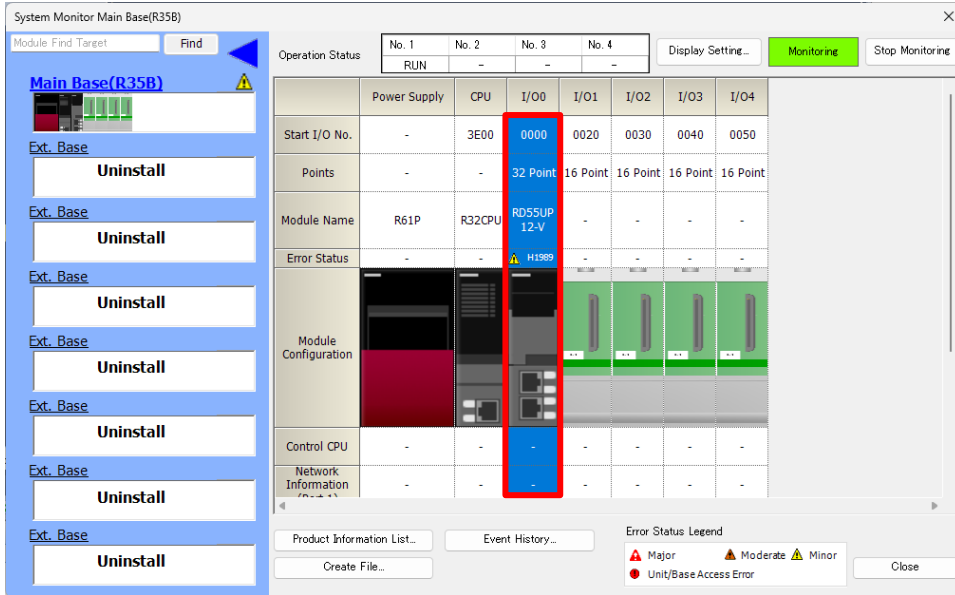

3. Check the error code on the displayed "Module Diagnostics" window.

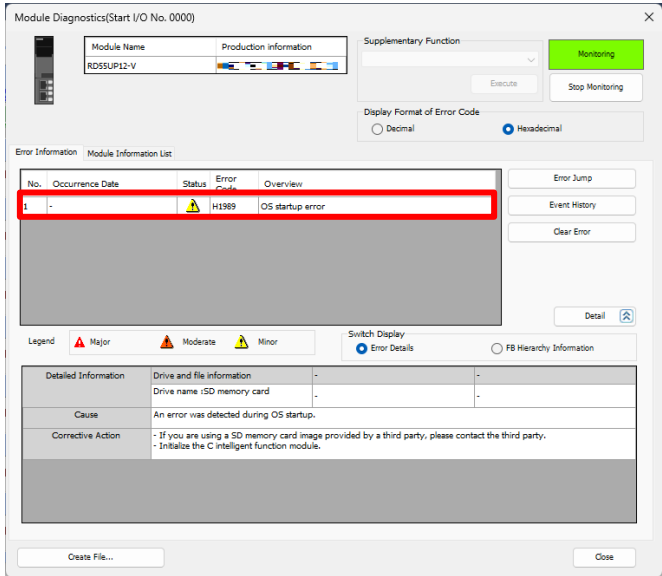

Case	Action
"H1989" is displayed as the error code.	Delete the partition of the SD memory card, and format it again. Then, follow the procedure described in "4.2" to write the image file for installing DataNavigateApp to the SD memory card again.
Any error code other than the above is displayed.	Refer to "MELSEC iQ-R C Intelligent Function Module User's Manual (Application)".

■ When DataNavigateApp cannot be accessed from a web browser

Follow the steps below to check if the personal computer and the C intelligent function module are correctly connected to the network.

1. Enter "cmd" in the search bar next to the start menu of the personal computer to open "Command Prompt".

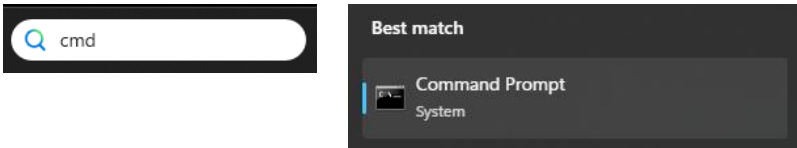

2. Enter "ping [IP address of the C intelligent function module]" in the command prompt.
3. Press the Enter key to check if the ping command properly responds, and then check the action listed below.

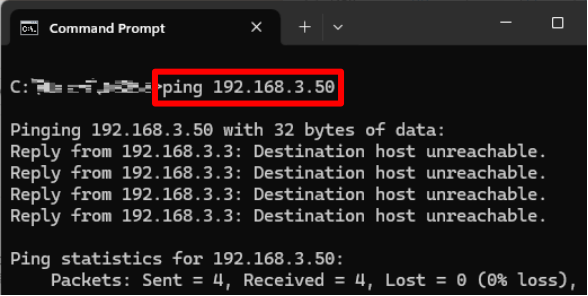
Case	Action
<p>If the ping command does not respond</p>  <pre> C:\> ping 192.168.3.50 Pinging 192.168.3.50 with 32 bytes of data: Reply from 192.168.3.3: Destination host unreachable. Reply from 192.168.3.3: Destination host unreachable. Reply from 192.168.3.3: Destination host unreachable. Reply from 192.168.3.3: Destination host unreachable. Ping statistics for 192.168.3.50: Packets: Sent = 4, Received = 4, Lost = 0 (0% loss), </pre>	<p>The Ethernet cable may not be correctly connected. Check if the Ethernet cable is correctly connected.</p>
	<p>The IP address of the C intelligent function module may not be correctly set. Refer to "4.3" in this manual to check if the IP address setting of the C intelligent function module is correct.</p>
	<p>Access from a specific IP address is blocked by an IP filter function such as a firewall. Disable the IP filter function or access from a different IP address.</p>
	<p>The personal computer and the C intelligent function module may not be connected to the same network. Refer to "4.3" and "4.4" in this manual to set the IP addresses of the personal computer and C intelligent function module.</p>
	<p>If the NAT/NAPT function of the router is used, the NAT/NAPT function may not be set correctly. Refer to "4.4" to check if the NAT/NAPT function is set correctly with the support tool.</p>

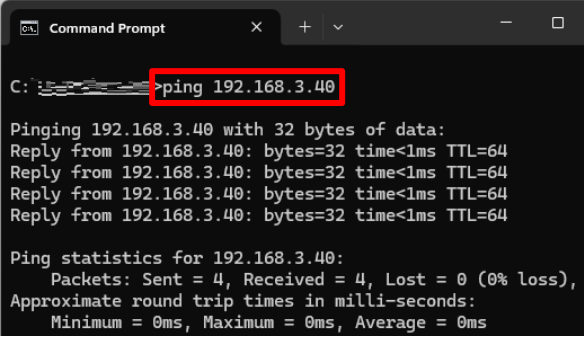
<p>If the ping command responds properly</p>  <pre>Command Prompt C: > ping 192.168.3.40 Pinging 192.168.3.40 with 32 bytes of data: Reply from 192.168.3.40: bytes=32 time<1ms TTL=64 Reply from 192.168.3.40: bytes=32 time<1ms TTL=64 Reply from 192.168.3.40: bytes=32 time<1ms TTL=64 Reply from 192.168.3.40: bytes=32 time<1ms TTL=64 Ping statistics for 192.168.3.40: Packets: Sent = 4, Received = 4, Lost = 0 (0% loss), Approximate round trip times in milli-seconds: Minimum = 0ms, Maximum = 0ms, Average = 0ms</pre>	<p>The SD memory card may not be correctly inserted into the C intelligent function module. Check if the SD memory card is correctly inserted.</p> <p>DataNavigateApp may be disabled. Power off and on the programmable controller, and check that the "USER" LED of the C intelligent function module turns on in green.</p> <p>If the "USER" LED does not turn on in green, DataNavigateApp may not be correctly written to the SD memory card. Refer to "4.2" in this manual to rewrite DataNavigateApp to the SD memory card.</p> <p>Port No. may not be specified in the web address entered in the web browser. Refer to "4.4" in this manual to check if the entered web address is correct.</p> <p>There may be a device with the same IP address as the personal computer or the C intelligent function module on the LAN to which they are connected. If there is, change the IP address to a unique one.</p>
---	--

■ When DataNavigateApp is not displayed properly in the web browser

If the UI or monitor values of DataNavigateApp displayed in your web browser are not displayed properly, old information may be displayed due to the cache of your web browser. Clear the cache of your web browser and access DataNavigateApp again.

5. TERMINATION PROCEDURE

To terminate this application, follow the steps below.

1. Click the  button on the top right of the application.
2. Select "Shutdown" to terminate DataNavigateApp.

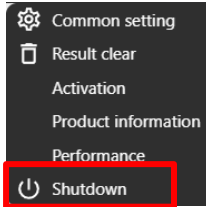

3. Power off the programmable controller.

CAUTION

Shut down the application before turning off the power.

If the C intelligent function module is powered off without shutting down DataNavigateApp, a file system error or similar issues may occur. Always shut down DataNavigateApp before powering off the C intelligent function module.

6. SETTINGS USING THE SUPPORT TOOL

DataNavigateApp can execute the following functions using the support tool in the exe format.

Function	Function overview
Initial setting	Set information on the C intelligent function module being used. The name, IP address, and connection destination of each C intelligent function module can be changed.
Security	Certificates and private keys required for each encrypted communication can be registered to ensure secure communication with e-mail and web browsers.
Update	Updates DataNavigateApp.
Maintenance	Acquires log files by connecting to the C intelligent function module.

6.1. Initial Setting

6.1.1. Connection destination setting

Register the C intelligent function module that will communicate with the support tool. Follow the steps below to set the connection destination.

1. Open the [Module setting] tab in the [Initial setting] window, and click the [+] button.

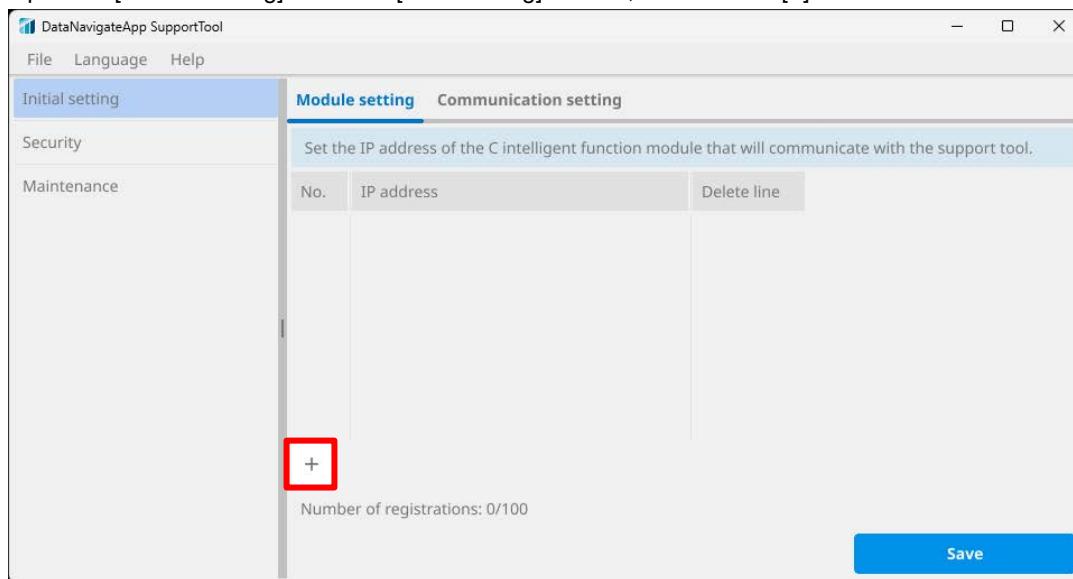

2. Click the [Not set] button.

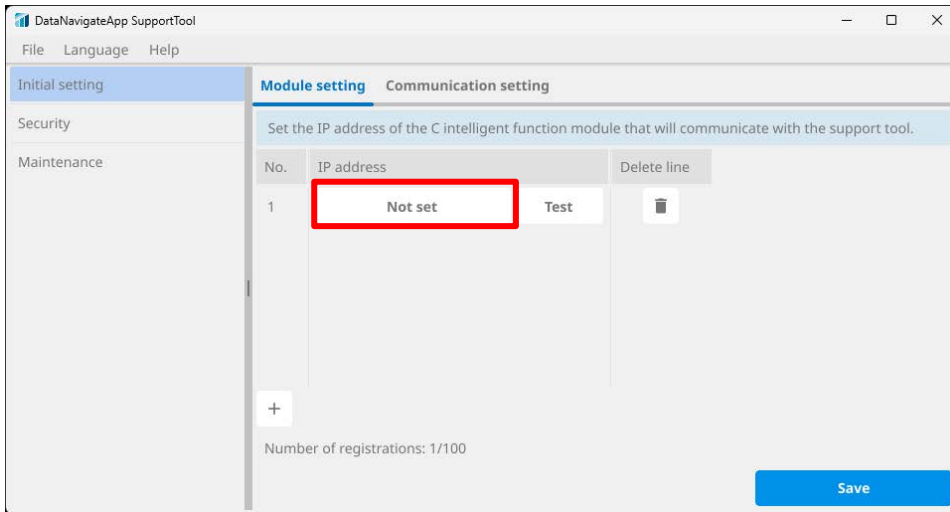

3. Set the IP address of the C intelligent function module that will communicate with the support tool.

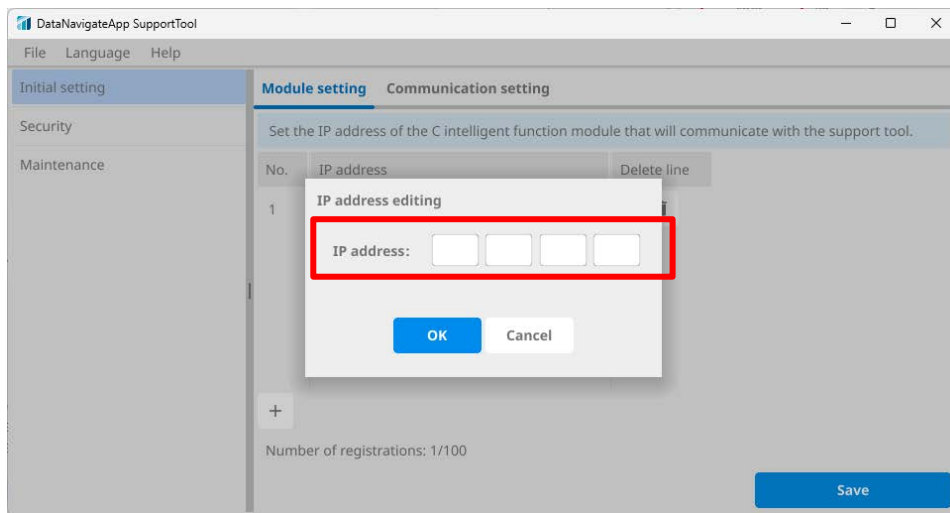

4. Click the [Save] button. Up to 100 modules can be registered.
Communication tests can be performed in the registration window.

6.1.2. Registration of external IP addresses

When the connection is established via a router using the NAT/NAPT function, register the IP address of the router as an external IP address.

- 1. Open the [Communication setting] tab in the [Initial setting] window, and click the [Not set] button.

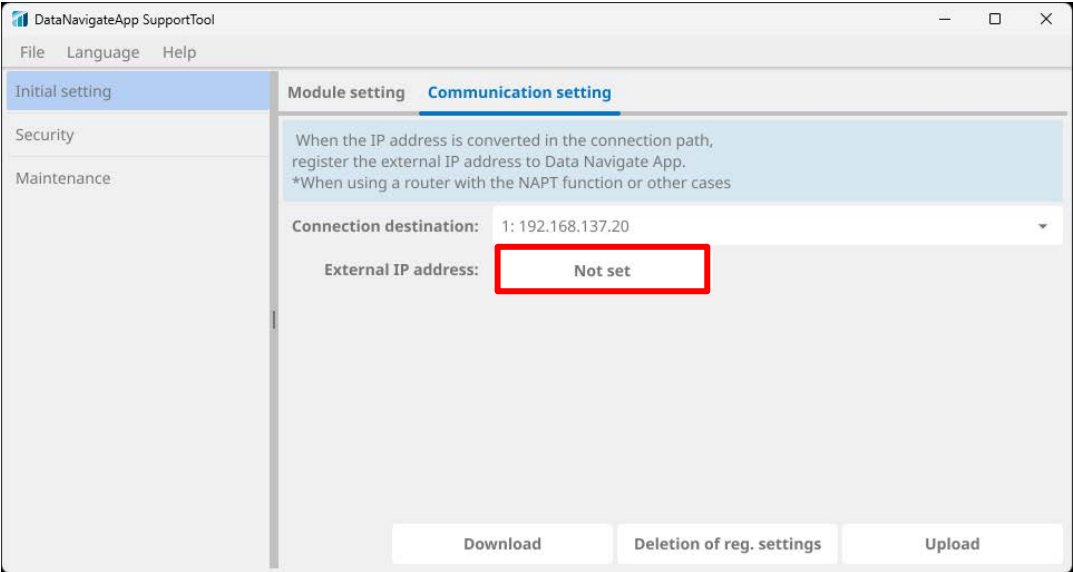

- 2. Set the IP address of the connected router as an external IP address.

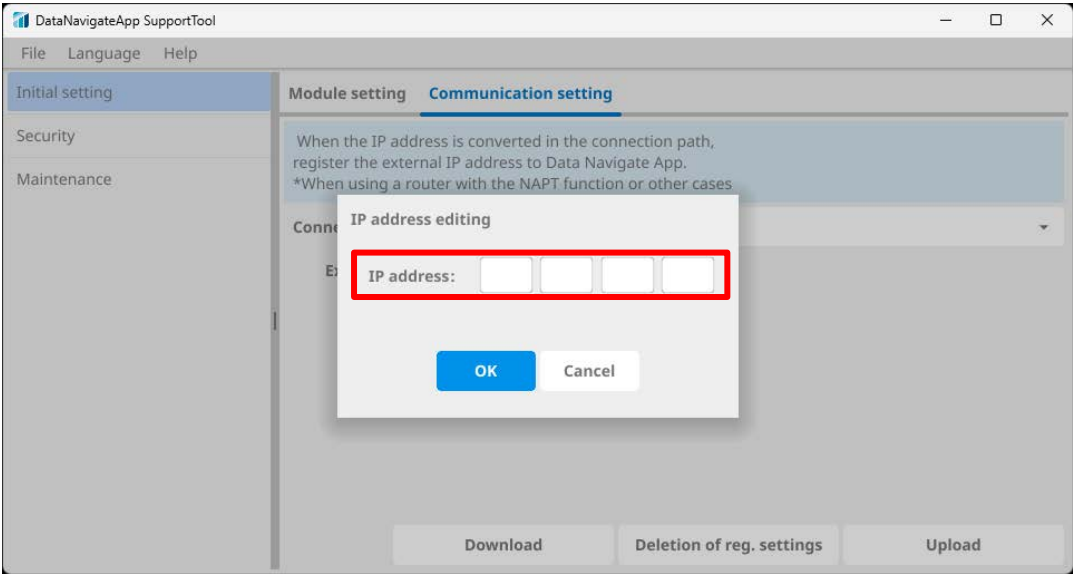

- 3. Click the [Upload] button.

6.2. How to Write Certificates Required for Encrypted Communication

To use various encrypted communications, the required certificates must be written to the C intelligent function module.

6.2.1. E-mail sending

The following shows the steps for writing the certificate required for encrypted communication of e-mail sending.

1. Open the [E-mail sending (SMTPS)] tab in the [Security] window.
2. For [Connection destination], select the IP address of the C intelligent function module that will use encrypted communication.
3. Select the storage destination of the required certificate for [Certificate].
4. Click the [Upload] button.

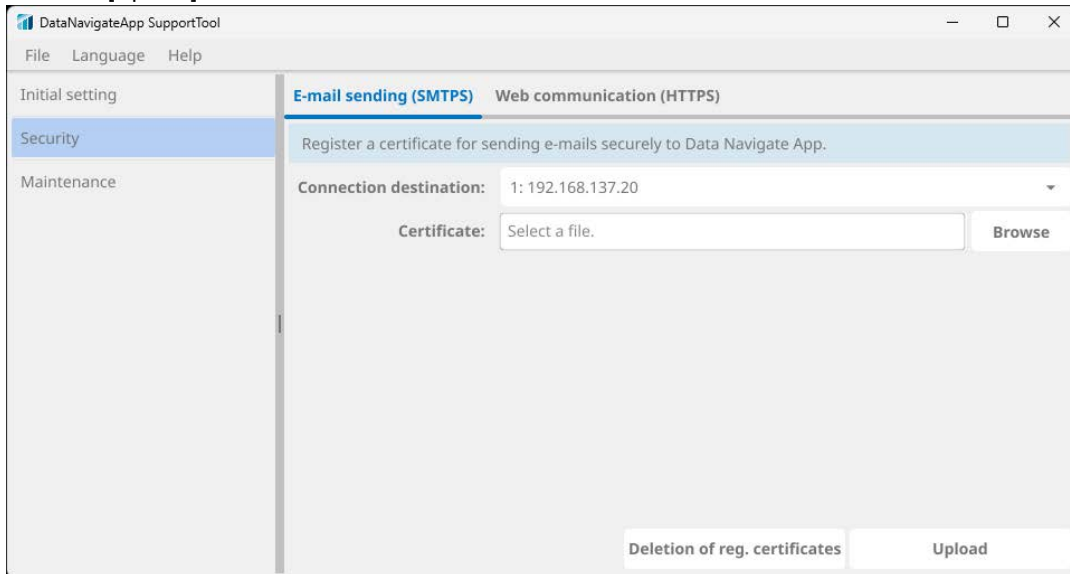

CAUTION

With the "Deletion of registered certificates" button, the registered certificates can be deleted. Even after the certificates are deleted, encrypted communication may still be available depending on the specifications and settings of the mail server.

6.2.2. Web communication

The following shows the steps for writing the certificate required for encrypted web communication.

1. Open the [Web communication (HTTPS)] tab in the [Security] window.
2. For [Connection destination], select the IP address of the C intelligent function module that will use encrypted communication.
3. Select the storage destination of the required certificate for [Certificate].
4. Select the storage destination of the required private key for [Private key].
5. Click the [Upload] button.

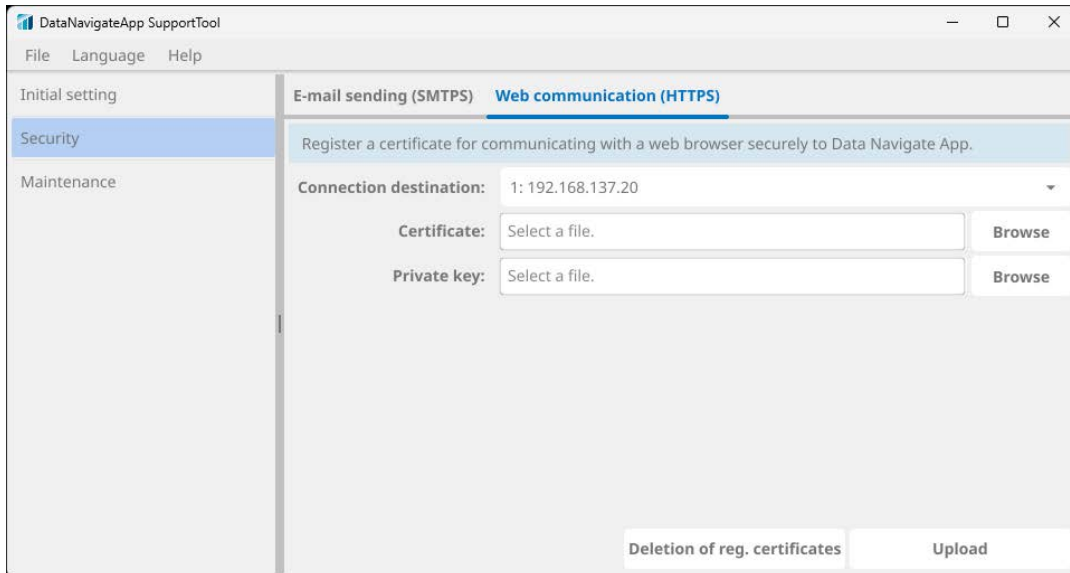

CAUTION

The method for accessing Data Navigation App differs during HTTPS communication. During HTTPS communication, entering the port No. is not required.

For HTTP communication: "http://(IP address of the C intelligent function module):3000"

For HTTPS communication: "https://(IP address of the C intelligent function module)"

6.3. How to Update DataNavigateApp

The following shows the steps for updating DataNavigateApp.

1. Open the [Maintenance] window.
2. Select the target C intelligent function modules for update.
3. Select the storage destination of the update file for [Update file].
4. Click the [Update] button.

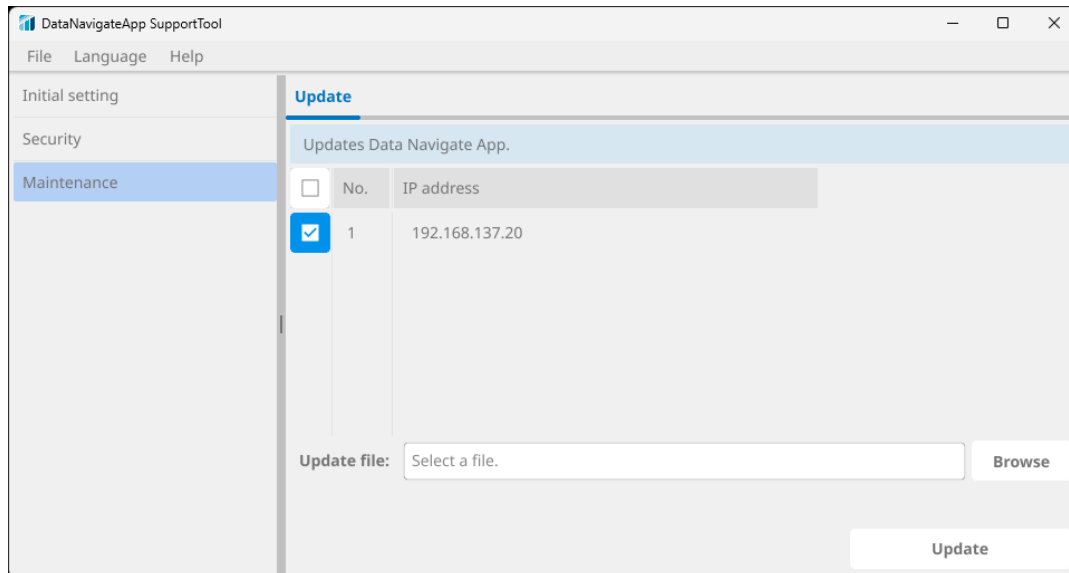

7. PROCEDURE FOR UNINSTALLING DataNavigateApp

1. Turn off the power and then remove the SD memory card from the C intelligent function module.
2. Insert the SD memory card into the personal computer and open Explorer.
3. Right-click [This PC] and select [Manage].
4. The [Computer Management] window will appear.
5. Select [Disk Management] under [Storage].
6. Select the partition in the SD memory card, right-click it, and execute [Delete Volume].

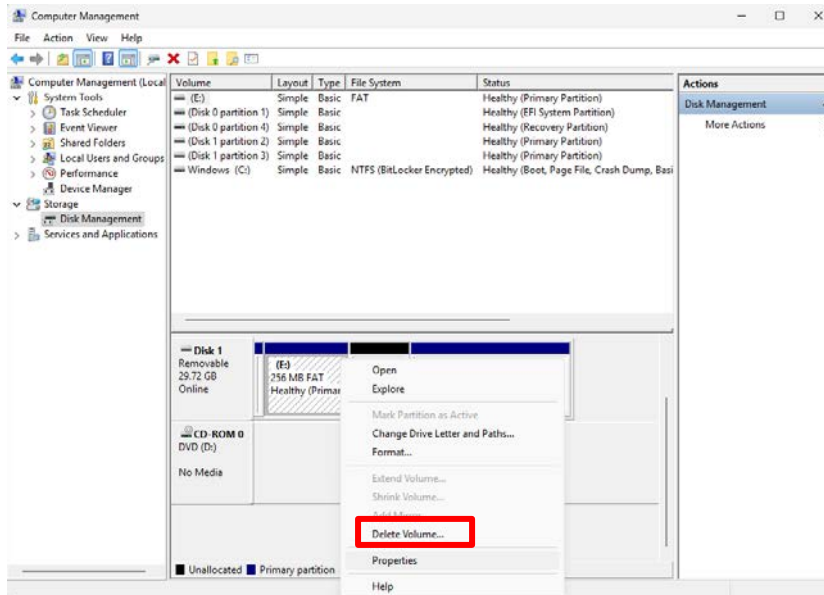

7. If there are multiple partitions, execute step 6 for all the partitions to set the volume of the SD memory card to the unassigned state.
8. By newly setting volume and formatting the SD memory card, data can be completely deleted.

REVISIONS

Revision date	No.	Description
October 2025	BCN-89999-9913-A	First edition
December 2025	BCN-89999-9913-B	Corrected

TRADEMARKS

Microsoft and Microsoft Edge are trademarks of the Microsoft group of companies.

Google Chrome is either a registered trademark or trademark of Google LLC.

The company names, system names, and product names mentioned in this manual are either registered trademarks or trademarks of their respective companies.

In some cases, trademark symbols such as '™' or '®' are not specified in this manual.

MITSUBISHI ELECTRIC Factory Automation Global Website

Locations Worldwide

<https://www.mitsubishielectric.com/fa/about-us/overseas/>