



SENSORLESS SERVO GLOBAL PM MOTOR

TYPE:

EM-A Series

Instruction Manual

■ Before you operate the EM-A motor, carefully read this manual, and correctly use the motor. Be sure to read the “Precautions Regarding Safety” described in this manual to ensure safety during operation.

■ After reading, store this manual at an appropriate place so that everyone can read the manual whenever necessary.
(Be sure to hand this manual to the operator.)

■ For product information and technical information about global PM motor, please see the following website.

<https://www.mitsubishi-electric.com/fa/>

SAFETY PRECAUTIONS

Carefully operate the Motor. An operation error may cause injury or electric shock.

To ensure operator safety, the safety precautions are ranked as “DANGER” and “CAUTION” in this instruction manual.



When a dangerous situation may occur if handling is mistaken leading to fatal or major injuries.



When a dangerous situation may occur if handling is mistaken leading to medium or minor injuries or physical damage.

Note that some items described as  may lead to major results depending on the situation. In any case, must follow instructions because important information described.

DANGER

General

- Before starting use of this EM-A Motor always read this manual and the nameplate.
- Do not use a motor in an application where a motor is driven by its load and runs at a speed higher than the maximum rotation speed.

Operation conditions and ambient conditions

- Do not place any inflammable near the EM-A Motor. Failure to observe this warning may cause fire or explode. A place to use the explosive powder or organic solvents, do not use the EM-A Motor.
- Do not use the EM-A Motor as elevator for human transport. Use of an EM-A Motor for such a purpose is prohibited by the Building Standard Law of Japan.
- If the equipment is to be used with an elevator, be sure to attach a safety device to prevent the elevator from accidental fall. Failure to observe this warning may cause physical injury and damage to the equipment.

Wiring

- Never connect an EM-A motor to the commercial power supply. There is a possibility of motor burnout.
- Be sure to ground the motor, and install a circuit breaker for each motor. Without grounding or circuit breaker, you may get an electric or physical injury.
- To wire the motor, be sure to observe the technical standards for electric equipment or interior wiring code by the corresponding electric power company.
- Be sure to supply the specified voltage to the EM-A Motor. If the voltage is too high, a fire may be caused.
- The motor is a synchronous motor with embedded magnets. High-voltage is generated at motor terminals while the motor is running even after the inverter power is turned OFF. Before wiring or inspection, the motor must be confirmed to be stopped.
- Before wiring and inspections, turn off the power and wait for 10 minutes or more until the lamp of inverter turns off. Then, confirm that the voltage is safe with a voltage tester and others. Otherwise, an electric shock may occur.
- To avoid an electric shock, insulate the connections of the power supply terminals.

Operation

- Never go near and touch the rotating parts (shaft, etc.) during operation. Failure to observe this warning may be injured.
- Always operate the motor within prescribed rotation speed range. Operating the motor outside the prescribed speed range could cause a motor explosion and damage.
- Before starting operation, each parameter must be confirmed and adjusted. Failure to observe this warning may cause some machines to make unexpected motions.



CAUTION

General

- If the motor is equipped with the holes of eyebolts, be sure to use the eyebolts to transport the motor.
- When using the eyebolts, be sure to use them with a two-point suspension. One-point suspension may cause damage or drop.
- Do not overtighten the eyebolts of the servo motor. Tightening too hard may damage the tap.

Operation conditions and ambient conditions

- Be sure to attach safety covers to the belts, chains, gears, etc.
- Do not use the indoor type Motor outdoors.
- Do not subject the servo motor shaft to more than the permissible load. Otherwise, the shaft may break, leading to injury.

Wiring

- If an electromagnetic contactor (MC) is used at the inverter's input side, this MC must not be started up in a frequent manner. Failing to do so may cause inverter damage.
- For elevator or high accuracy positioning drive, please use direct current (quick) braking method.
- Please check manual of inverter for the wiring length between a motor and inverter.
- Use one dedicated motor for one inverter. Multiple motors cannot be connected to an inverter.

Operation

- Always operate within the allowable torque range.
- Do not use the motor in applications where it is subjected to excessive impact torques (striking a stopper at high speed, etc.) while in a stopped condition.
- During operation, if the motor generates an abnormal noise, vibrates extremely, or shows abnormal characteristics, be sure to stop the motor, and inspect the motor.
- During operation, keep your body away from the EM-A Motor. If you touch the EM-A Motor during operation, you may be injured or get burned.
- The electromagnetic brake on the EM-A motor is designed to hold the motor shaft and should not be used for ordinary braking.

Combined motor and inverter operation

- The EM-A motor is equipped with an internal magnet, and maintenance should therefore be performed only by the sales outlet where purchased. Unauthorized disassembly could result in the permanent magnet rotor becoming stuck to other metal parts of the motor, making the maintenance task difficult, and possibly causing injuries. Moreover, a poor work environment could result in other metallic scraps and chips, etc., becoming adhered to the magnet, resulting in motor failure. Never attempt unauthorized motor modifications.
- Voltage is generated at the motor terminals while the motor is rotating. Therefore, always verify that the motor is stopped or that the power has been shut off before performing maintenance.
- The EM-A motor will become quite hot during operation. Take care not to touch the motor with your hands or body. Failure to observe this could lead to burns etc.

Storage

- Note the followings when storing the EM-A motor for an extended period of time(guideline: three or more months).
- If it is stored in a dusty or damp place, make adequate provision, e.g. cover the whole product.
- If the insulation resistance of the winding decreases, check how to store the equipment.
- Though the EM-A motor is rust-proofed before shipment using paint or rust prevention oil, rust may be produced depending on the storage conditions or storage period. If the EM-A motor is to be stored for longer than six months, apply rust prevention oil again especially to the machined surfaces of the shaft, etc.
- Before using the product after storage for an extended period of time, hand-turn the EM-A motor output shaft to confirm that nothing is wrong with the EM-A motor. When the EM-A motor is equipped with an electromagnetic brake, check it after releasing the electromagnetic brake with the brake power supply.
- When the product has been stored for an extended period of time, contact your local sales office.



CAUTION

Disposal of waste

Please dispose an EM-A motor and other options according to your local laws and regulations.

<U.S. customary units>

U.S. customary units are not shown in this manual. Convert the values if necessary according to the following table.

Quantity	SI(metric) unit	U.S. customary unit
Mass	1[kg]	2.2046[lb]
Length	1[mm]	0.03937[inch]
Torque	1[N·m]	141.6[oz·inch]
Moment of inertia	1[(× 10 ⁻⁴ kg·m ²)]	5.4675[oz·inch ²]
Load (thrust load/axial load)	1[N]	0.2248[lbf]
Temperature	N[°C] × 9/5+32	N[°F]

Model name description

■Motor

○Model name

EM	A	M	F	B	K	
EM: Eco motor	A: A series	M: motor	F: Flange	Blank: Without brake B: With brake	Blank: Without key K: With key	Blank: IP44 W: IP65 T: With terminal box

○Specifications

Output	Rotation speed	Voltage	Special specification
0.1 to 7.5kW	3000r/min	200V 400V(0.4 to 7.5kW)	• Direction of terminal box • Overseas standards

■Inverter

FR	E820	0.75K
FR: FREQROL	E720EX: Three-phase 200V E820: Three-phase 200V E840: Three-phase 400V E820S: Single-phase 200V E810W: Single-phase 100V	Output E720EX: 0.1 to 3.7kW E820: 0.1 to 7.5kW E840: 0.4 to 7.5kW E820S: 0.1 to 2.2kW E810W: 0.1 to 0.75kW

※When using a single-phase input inverter, the combination motor is 200V class.

※Refer to the manual of inverter for more information.

When making an order or an inquiry, please inform us of the following basic specifications.

(Example)

Model name	Output	Rotation speed	Voltage	Special specification
EM-AMFB	0.75kW	3000r/min	200V	

Contents

1. Product check	4
2. Operation Condition and Ambient Condition	4
3. Installation and Adjustment	4
4. Connection	5
5. Wiring	5
6. Specifications	6
7. Wiring	7
8. Brake	11
9. Operation	14
10. Maintenance	14
11. Troubleshooting	14
12. Contact Us	15
13. Labeling (product name) based on the Marking for the Restriction of the Use of Certain Hazardous Substances in Electrical and Electronic Equipment	16

1. Product Check

- (1) Check that the model number, output, Rated rotation speed, etc. You specified are written on the nameplate.
- (2) Check that the product is not damaged during transportation.
- (3) Check the screws and bolts for looseness.

2. Operation Conditions and Ambient Conditions

- (1) Do not place any inflammable near the EM-A Motor. Failure to observe this warning may cause fire or explode.
- (2) Do not use the EM-A Motor as elevator for human transport. Use of an EM-A Motor for such a purpose is prohibited by the Building Standard Law of Japan.
- (3) If the equipment is to be used with an elevator, be sure to attach a safety device to prevent the elevator from accidental fall. Failure to observe this warning may cause physical injury and damage to the equipment.
- (4) Do not use EM-A Motor in an application where a motor is driven by its load and runs at a speed higher than the maximum rotation speed.

3. Installation and Adjustment

- (1) Be sure to attach safety covers to the belts, chains, gears, etc.
- (2) Install the motor in appropriate place where humidity is low, and with a little dust. Check that the ambient temperature is from 0 to +40°C and the relative humidity is 90% or less, does not freeze. In addition, please check that installed place is good cooling condition.
- (3) Install the motor on a rigid and thermal conductive base with bolts having strength of 8.8 or above. Adjust the flatness of the installation surface to 0.2mm or less.
- (4) Be sure to use the bolts of the corresponding size as shown in Table 3-1.
- (5) Be sure to use the EM-A motor within the specified environment, and mount the EM-A motor on a machine having the equivalent heat dissipation effect as the Table.3-2 aluminum flange.
The temperature of the EM-A motor increases differently depending on its mounting environment, operating conditions, etc. Make sure to check the temperature with an actual machine.

Table 3-1 : Corresponding Bolt Sizes

Output(kW)	Bolt sizes
0.1 to 0.75	Hexagon(socket head)bolt M6
1.5, 2.2	Hexagon(socket head)bolt M8
3.7 to 7.5	Hexagon(socket head)bolt M12

Table 3-2 : Corresponding Flange Sizes (made of aluminum)

Output(kW)	Flange Sizes(mm)
0.1, 0.2	250×250×6
0.4, 0.75	250×250×12
1.5	300×300×20
2.2	400×400×20
3.7, 5.5	550×550×30
7.5	650×650×35

- (6) Use eyebolts to transport the motor with screw holes for eyebolt.
When you use a hanging bolt, please make sure to use two eyebolts.

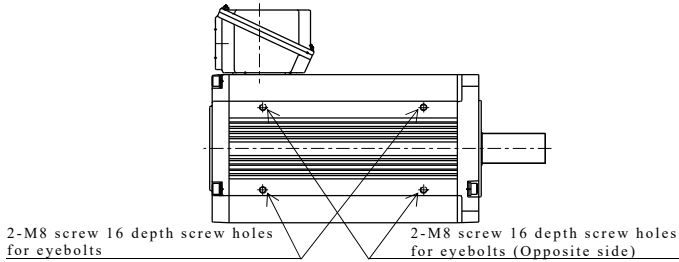

Fig.3 Screw hole for eyebolt. (3.7 to 7.5kW)

4. Connection

- (1) To properly connect the EM-A Motor to the machine, reduce the eccentricity between the motor and machine to 0.05mm or less. Use the flexible coupling to easily connect the motor to the machine.
- (2) Adjust deflection amount of the chain to 4% of the span. (refer to Fig.4). The deflection amount is too large, give a great shock to the EM-A Motor at starting. The results, the EM-A Motor may be damaged.
- (3) To prevent damage caused by the overhang load, adjust the positions of the sprocket, gear, pulley, etc. decide the loading position as close as possible to the joint of the output shaft and the gear case.
- (4) The tolerance for the holes of the sprocket, coupling, etc. is H8 degree. Using the tap on the output shaft, smoothly install the sprocket, coupling, etc. Please use shock-less hammer for those install. An iron hammer may be damaged the bearing, gear, etc., by a strong impact.

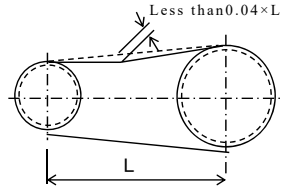

Fig.4 deflection amount of chain

5. Wiring

- (1) EM-A Motor is permanent magnet motor. Please connect this motor to a dedicated inverter for operation. Driving the motor with a commercial power source might be damaged by burnout.
- (2) Be sure to ground the motor, and install a circuit breaker on each motor. Without grounding or circuit breaker, you may get an electric shock.
- (3) To wire the motor, use high-quality wiring parts, and be sure to observe the technical standards for electric equipment and the regulations for internal wiring specified by the corresponding electric power company. The outline is shown in Table 5. If the wiring distance is long, adjust the voltage drop to 2% or less.
- (4) Install an optimum motor protector on each motor. Without any protector, the motor may cause a fire at the time of a problem.

Table 5. Motor Wiring

Applicable inverter	Terminal screw size *4	Tightening torque N·m	Crimp terminals		Wire size							
			R/L1 S/L2 T/L3	U, V, W	HIV wires etc.(mm ²)※1			AWG※2		PVC wires etc.(mm ²)※3		
					R/L1 S/L2 T/L3	U V W	Grounding Cable	R/L1 S/L2 T/L3	U V W	R/L1 S/L2 T/L3	U V W	Grounding cable
FR-E720EX-0.1K to 0.75K	M3.5	1.2	2-3.5	2-3.5	2	2	2	14	14	2.5	2.5	2.5
FR-E820-0.1K to 0.75K												
FR-E720EX-1.5K to 3.7K												
FR-E820-1.5K,2.2K												
FR-E840-0.4K to 3.7K	M4	1.5	2-4	2-4	2	2	2	14	14	2.5	2.5	2.5
FR-E820-3.7K												
FR-E820-5.5K	M5	2.5	5.5-5	5.5-5	5.5	5.5	5.5	10	10	6	6	6
FR-E840-5.5K	M4	1.5	5.5-4	2-4	3.5	2	3.5	12	14	4	2.5	4
FR-E820-7.5K	M5	2.5	14-5	8-5	14	8	5.5	6	8	16	10	6
FR-E840-7.5K	M4	1.5	5.5-4	5.5-4	3.5	3.5	3.5	12	12	4	4	4

- *1 The cable size is that of the cable (HIV cable (600V class 2 vinyl-insulated cable) etc.) with continuous maximum permissible temperature of 75°C. Assumes that the surrounding air temperature is 50°C or less and the wiring distance is 20m or less.
- *2 The recommended cable size is that of the cable (THHW cable) with continuous maximum permissible temperature of 75°C. Assumes that the surrounding air temperature is 40°C or less and the wiring distance is 20m or less. (For the use in the United States or Canada, refer to INSTRUCTION MANUAL of inverter.)
- *3 The recommended cable size is that of the cable (PVC cable) with continuous maximum permissible temperature of 70°C. Assumes that the surrounding air temperature is 40°C or less and the wiring distance is 20m or less. (Selection example for use mainly in Europe.)
- *4 The terminal screw size indicates the terminal size for R/L1, S/L2, T/L3, U, V, W, PR, P/+, N/-, P1 and a screw for earthing (grounding).

6. Specifications

1) Standard specifications of EM-A Motor

Standard specifications of EM-A Motor are shown Table 6.

Table 6 Standard specifications of EM-A Motor

Rated Output(kW)		0.1	0.2	0.4	0.75	1.5	2.2	3.7	5.5	7.5	
Rated Voltage(V)	200V Class	130	135	160	165	170	165	160	170	165	
Rated Current(A)		0.55	1.1	1.8	3.3	6.1	9.3	16.5	22.0	31.0	
Stall Current(A)		0.55	1.1	1.8	3.3	6.1	9.3	16.5	22.0	31.0	
Rated Voltage(V)	400V Class	—	—	320	330	340	330	320	340	330	
Rated Current(A)		—	—	0.9	1.7	3.1	4.7	8.3	11.0	15.5	
Stall Current(A)		—	—	0.9	1.7	3.1	4.7	8.3	11.0	15.5	
Insulation class		130(B)						155(F)			
Number of poles		4				6					
Rating		Continuous(S1)									
Flange size		□90	□110		□125		□176				
Protective construction		IP44 *1(Except for the shaft hole)									
Rated rotation speed(r/min)		3000									
Maximum rotation speed(r/min)		4000									
Speed fluctuation ratio (%)		±0.05									
Motor rated torque(Nm)		0.32	0.64	1.27	2.39	4.78	7.00	11.8	17.5	23.9	
Motor maximum torque (%)		200 *2									
Permissible radial load(N) *3		392		490		686		1470			
Permissible thrust load(N)		196		294		490		980			
Positioning accuracy		200 pulses/rev or more *4									
Structure		Totally enclosed self-cooling									
Color		Black									
Ambient temperature	drive	0~+40°C(No freezing)									
	stock	-15~+70°C(No freezing)									
Ambient humidity		90%RH or less(non-condensing)									
Elevation		1000m or less above sea level									
Vibration		4.9m/s ² for continuous operation, 9.8m/s ² for instantaneous operation.									
Installation place		Indoors (without corrosive gas, oil mist, flammable gas, dust and dirt etc.)									
Compatible Inverter	200V Class	Output(□K)	0.1	0.2	0.4	0.75	1.5	2.2	3.7	5.5	7.5
		FR-E720EX-□K	○	○	○	○	○	○	○	-	-
		FR-E820-□K	○	○	○	○	○	○	○	○	○
		FR-E820S-□K	○	○	○	○	○	○	-	-	-
		FR-E810W-□K	○	○	○	○	-	-	-	-	-
	400V Class	FR-E840-□K	-	-	○	○	○	○	○	○	○
Inverter Input voltage/frequency		200V Class	E720EX/E820			Three phase 200 to 240V 50/60Hz					
			E820S			Single phase 200 to 240V 50/60Hz					
		E810W			Single phase 100 to 120V 50/60Hz						
		400V Class		E840			Three phase 380 to 480V 50/60Hz				

*1 W type motor is IP65.

*2 Excluding single-phase input.

*3 With load position at the center of the output shaft.

*4 Please check manual of inverter for the wiring length between a motor and inverter

*5 Be sure to perform initial setup of PM parameters (Pr.998) when using an EM-A motor for operation.

See the inverter instruction manual for models.

2) Motor torque characteristic

The operating torque characteristics are as follows.

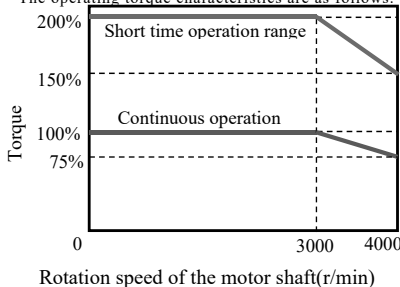

*1 When the input voltage is low, the torque may be reduced.

*2 The continuous operation torque is 90% at 10r/min or less(for 1.5kW or higher)

*3 When driving the EM-A motor under high load in the low-speed range (especially at 15r/min or lower for 0.75kW or lower, or at 10r/min or lower for 1.5kW or higher), the protective function of the electronic thermal O/L relay(E.THT) may be activated and short time operation range torque may not be generated.

*4 At low speeds (approx.100r/min or less), speed may be uneven due to torque ripples caused by magnetic attraction/repulsion forces of the motor.

*5 Short time maximum torque(200%) is only when the power supply input of the inverter is three-phase.

*6 For the single phase 100V power input models, output voltage decreases by applying motor load, and output current increases compared to the three-phase power input models. The load must be reduced so that output current does not exceed the rated motor current.

7. Wiring

1) Motor Wiring

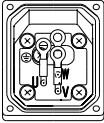
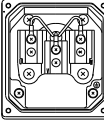
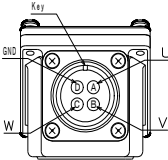
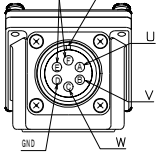
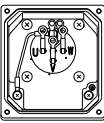
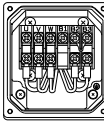
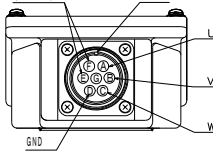
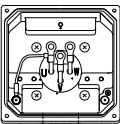
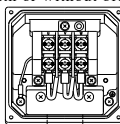
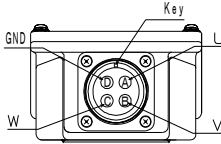
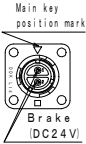
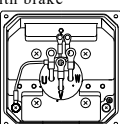
Output (kW)	EM-AMF(B)(K)T Lug type	EM-AMF(B)(K)T Terminal type	EM-AMF(K)W Connector type	EM-AMFB(K)W Connector type
0.1 to 2.2	Without brake 	Without brake 	 Connector: CE05-2A18-10PD-D	0.1 to 0.75kW 1.5, 2.2kW(400V) Brake (DC24V)  Key U V W GND Connector: CE05-2A18-12PD-D
	With brake 	With brake 		1.5, 2.2kW(200V) Brake (DC24V)  Key U V W GND Connector: CE05-2A20-15PD-D
3.7 to 7.5	Without brake 	With or without brake  ※The brake power connection method for models with a brake is the same brake connector specification as the connector type.	 Key U V W GND Motor connector 3.7,5.5kW:CE05-2A22-22PD-D 7.5kW:CE05-2A32-17PD-D	 Main key position mark U V W Brake (DC24V) Brake connector CMV1-R2P
	With brake 			

*1 For wiring of brake, refer to 2) and 3) in this section.

*2 For wiring of motor compatible with overseas standards, refer to manual(No. IB-2259).

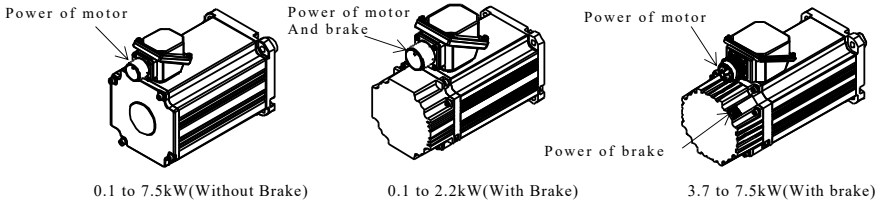
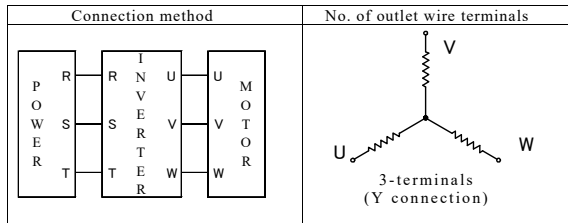

Fig.7



Direction of rotation: Counter Clockwise (viewed from output shaft end)

*Motor rotation can be reversed by switching any 2 wire of the U, V, W connections, or by executing the inverter's REVERSE command.

2) Brake Wiring(Lug type)

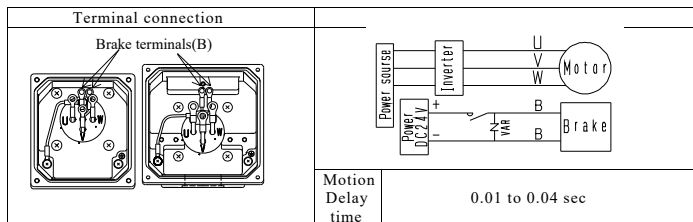

3) Brake Wiring(Terminal type)

Inverter	Motor		Connection (factory shipment)	Separate braking method	Direct current(quick) braking method
	In put	Out put			
0.1 to 2.2kW					
			<p>0.1 to 2.2kW</p>	<p>Connection bar (Upper line)</p>	<p>Connection bar (Upper line)</p>
			Motion Delay time	0.1 to 0.3sec	0.01 to 0.04sec

Notes

- 1) Connect the positive(+) side of the 24V DC power supply to B1, and the negative(-) side to B3. The surge absorber(VAR) must be installed between 24V DC.
- 2) Braking wires are connected to separate braking method from factory shipment. Direct current (quick) braking method remove a connection bar according to the upper figure.
- 3) terminal block has 2 lines of terminals (upper and lower line). Be sure to connect power supply wires to upper line terminals according to the upper figure. If connect to the lower line, brake will not be released.
- 4) No manual release mechanism is included. Electrically release the electromagnetic brake by supplying 24V DC power.
- 5) A capacitor for power factor improving cannot be connected to the motor circuit.
- 6) Set so that the brake is applied after stopped motor rotation.

4) Brake Wiring (Connector type)

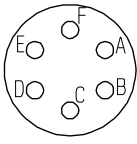
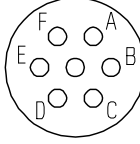
Connector pin assignment		
		A-Power(U) B-Power(V) C-Power(W) D-Earth E, F-Brake power(DC24V)
0.1 to 0.75kW	1.5 to 2.2kW	

- (1) Configure an electromagnetic brake circuit so that it is activated also by an external emergency stop switch.
- (2) Prepare the following power supply for use with the electromagnetic brake only. The electromagnetic brake terminals(E/F) have no polarity.

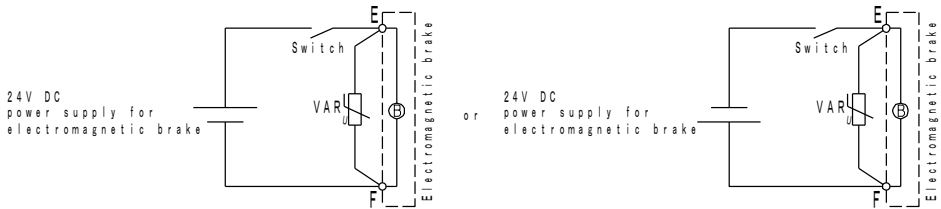

The surge absorber (VAR) must be installed between E and F. For a selection example of the surge absorber, refer to Brake specifications(P.12).

When a diode is used as a surge absorber, it will take longer to activate the electromagnetic brake.

5) Motor connector



Power supply connector	Plug (DDK)		Cable clamp(DDK)	
	Model	Type	Cable Outer diameter [mm](reference)	Model
CE05-2A18-10PD-D	CE05-6A18-10SD-D-BSS Applicable wire size: AWG14 to 12	Straight	8.5 to 11.0	CE3057-10A-2-D
	CE05-8A18-10SD-D-BAS Applicable wire size: AWG14 to 12	Angle	10.5 to 14.1	CE3057-10A-1-D
CE05-2A18-12PD-D	CE05-6A18-12SD-D-BSS Applicable wire size: AWG16 or less	Straight	8.5 to 11.0	CE3057-10A-2-D
	CE05-8A18-12SD-D-BAS Applicable wire size: AWG16 or less	Angle	10.5 to 14.1	CE3057-10A-1-D
CE05-2A20-15PD-D	CE05-6A20-15SD-D-BSS Applicable wire size: AWG14 to 12	Straight	9.5 to 13.0	CE3057-12A-2-D
	CE05-8A20-15SD-D-BAS Applicable wire size: AWG14 to 12	Angle	12.5 to 16.0	CE3057-12A-1-D
CE05-2A22-22PD-D	CE05-6A22-22SD-D-BSS Applicable wire size: AWG10 to 8	Straight	9.5 to 13.0	CE3057-12A-2-D
	CE05-8A22-22SD-D-BAS Applicable wire size: AWG10 to 8	Angle	12.5 to 16.0	CE3057-12A-1-D
CE05-2A32-17PD-D	CE05-6A32-17SD-D-BSS Applicable wire size: AWG6 to 4	Straight	22.0 to 23.8	CE3057-20A-2-D
	CE05-8A32-17SD-D-BAS Applicable wire size: AWG6 to 4	Angle	24.0 to 26.6	CE3057-20A-1-D
CMV1-R2P	CMV1-SP2S-S Applicable wire size: 4.0 to 6.0mm	Straight	22.0 to 23.8	CE3057-20A-2-D
	CMV1-AP2S-S Applicable wire size: 4.0 to 6.0mm	Angle	24.0 to 26.6	CE3057-20A-1-D

8. Brake

1) Structure and operation

Fig.8 shows the structure of the brake.

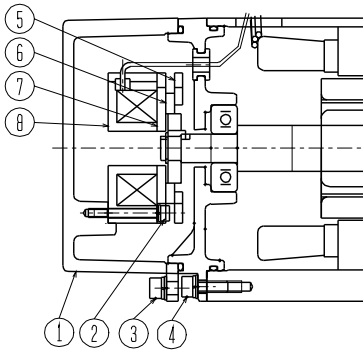

Fig.8

ITEM	DESCRIPTION
1	Brake cover
2	Hexagon bolt(Brake fixing)
3	Hexagon bolt(Cover fixing)
4	Hexagon bolt(Frame fixing)
5	Side plate
6	Brake lining
7	Armature
8	Field core

2) Brake specifications(DC24V)

Table 8 Standard Specifications for Brake

Motor output(kW)	0.1	0.2	0.4	0.75	1.5	2.2	3.7	5.5	7.5
Brake type	Dry type brake(Safety brake)								
Braking voltage(V)	DC24								
Braking current(A)	0.29	0.48	0.63	1.13					
static friction torque (Nm)	1.0	3.6	10.6	35.8					
Brake resistance (at 20°C)(Ω)	82.3	50.1	38.1	21.3					
Inductance(H)	2.33	1.92	3.46	3.37					
Release delay time (s)	0.05	0.09	0.18	0.20					
Braking delay time (s)	0.03	0.045	0.06	0.10					
Permissible braking work	Per braking(J)	210	630	2095	3580				
	Per hour(J)	2100	6300	20950	35800				
Brake life	Number of braking cycles(times)	1000	1000	1000	1000				
	Work per braking(J)	210	630	2095	3580				
Selection example of surge absorbers to be used	For the suppressed voltage 125V	TND20V-680KB							
	For the suppressed voltage 350V	TND10V-221KB							

3) Selection of surge absorbers for brake circuit

The following shows an example how to select a varistor with a surge absorber.

(a) Selection conditions

Item	Condition
Electromagnetic brake specification	R[Ω]: Resistance L[H]: Inductance Vb[V]: Power supply voltage
Desired suppression voltage	Vs[V] or less
Durable surge application time	N times

(b) Tentative selection and verification of surge absorber

(1) Maximum allowable circuit voltage of varistor

Tentatively select a varistor whose maximum allowable voltage is larger than Vb [V]

(2) Brake current (Ib) $I_b = V_b / R$ [A]

(3) Energy (E) generated by brake coil $E = (L \times I_b^2) / 2$ [J]

(4) Varistor limit voltage (Vi)

From the energy (E) generated in the brake coil and the varistor characteristic diagram, calculate the varistor limit voltage (Vi) when the brake current (Ib) flows into the tentatively selected varistor during opening of the circuit.

Vi is favorable when the varistor limit voltage (Vi) [V] is smaller than the desired suppressed voltage (Vs) [V].

If Vi is not smaller than Vs, reselect a varistor or improve the withstand voltage of devices.

(5) Surge current width (τ)

Given that the varistor absorbs all energies, the surge current width (τ) will be as follows.

$$\tau = E / (V_i \times I_b) \text{ [S]}$$

(6) Examining surge life of varistor

From the varistor characteristic diagram, the guaranteed current value (Ip) in which the number of the surge application life is N at the surgecurrent width (τ). Calculate the guaranteed current value (Ip) ratio to brake current (Ib).

If an enough margin is ensured for Ip/Ib, the number of the surge application life N [time] can be considered as favorable.

4) About the brake sequence

When using the motor's brake, use the brake opening request signal (BOF) of the FR-E700EX(BOF) in the sequence.

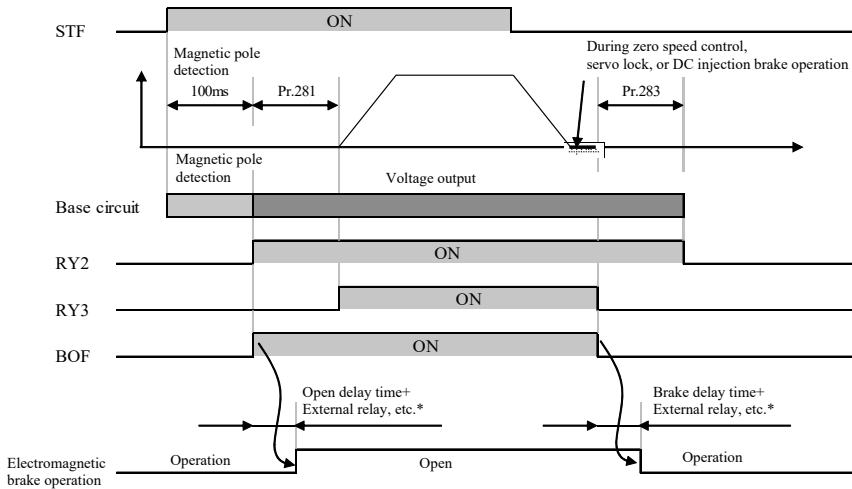

*The release of the electromagnetic brake is delayed for the electromagnetic brake release/operation time and the operation time of the relays, etc. in external circuits.

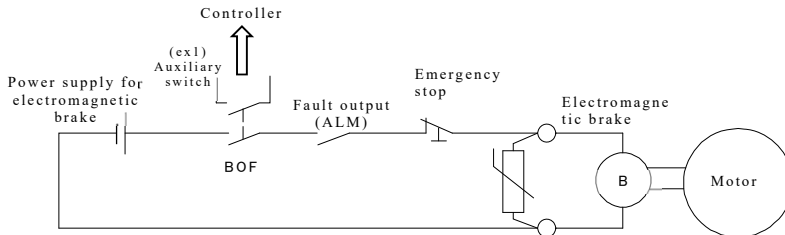

- ※ Before operating the motor, be sure to periodically confirm that the electromagnetic brake operates properly.
- ※ Under position control, when performing brake operations (servo off), the home position is lost, therefore the home position return operation is necessary.
- ※ Using Pr.538 Current position retention function, the current position data can be held when servo off (except for the power off). Do not use the current position retention function if the motor shaft is not fixed by the electromagnetic brake or the like, because motor shaft rotation causes a position fault.

CAUTION

- (1) The electromagnetic brake is provided to prevent a drop at a power failure or alarm occurrence during vertical drive or to hold a shaft at a stop. Do not use it for braking.
 - (2) Since disappear the home position when doing servo off, the starting point return is necessary.
 - (3) Do not energize only the brakes. Otherwise, it may cause a malfunction.
 - (4) Due to its structure of brake, it may produce a sliding sound of brake lining, but it does not affect its performance.
 - (5) Though the brake lining may rattle during operation, it poses no functional problem.
 - (6) Before operating the motor, be sure to periodically confirm that the electromagnetic brake operates properly.
 - (7) When driving the motor during with closed electromagnetic brake, the electromagnetic brake may be damaged by overheat. Use an auxiliary switch contact to check the brake operating state, and build a power circuit preventing the driving in situation when electromagnetic brake is closed.
- (Ex1) Use the auxiliary switch contact for BOF.

9. Operation

- EM-A Motor is permanent magnet motor. Please connect this motor to a dedicated inverter for operation. Driving the motor with a commercial power source might be damaged by burnout.
- Use one dedicated EM-A Motor for one inverter. Multiple EM-A Motors cannot be connected to a inverter.
- Always operate within the prescribed rotation speed range. Operating the motor outside the prescribed rotation speed range could cause motor damage.

Before turning on the switch

(1) Check the bolt tightening condition at each section.

Check that the foundation bolts, sprocket bolts, coupling bolts, etc. are tightened properly.

(2) Verify that the wiring to the inverter is correctly connected, that the terminal box cover is attached, and that the breaker capacity and over-current protection relay settings are appropriate.

Operation

(1) To operate the EM-A Motor, observe the allowable loading torque range.

(2) During operation, if the motor generates an abnormal noise, vibrates extremely, or shows abnormal characteristics, be sure to stop the motor, and inspect the motor.

(3) During operation, keep your body away from the EM-A Motor. If you touch the EM-A Motor during operation, you may be injured or get burned.

(4) Motor operation begins approximately 0.1s (Initial magnetic pole detection time) after the START signal input.

10. Maintenance

●Do not modify the EM-A Motor.

●Be sure to turn off the power before inspecting or repairing the motor.

(1) Daily check

Check item	Check method	Description
Current	Using ammeter	Check that the actual current value is equal to the rated current value specified on the nameplate or less.
Noise	Hearing	Directly check the noise with your ear using a noise detector bar. The motor should not generate any abnormal noise.
Surface temperature	Thermometer	Obtain the motor frame surface temperature rise value by subtracting the ambient temperature value from the motor frame surface temperature value.(80°C or less.)
Vibration	Vibration meter	Check the vibration of the frame. The obtained vibration values should be 4.9m/s ² or less.

(2) Periodical inspection

Periodically check the motor and replace the damaged parts while referring to the below.

Check item	Schedule	Description
*Oil seal replacement(IP65 only)	Every 8,000Hours (3years)	Replace every 8,000 hours of operation or every 3 years, whichever is earlier.
Looseness of foundation bolts	Every 6 months	If the foundation bolts are loose, retighten the bolts.
*Bearing replacement	Every 8,000Hours (3years)	If the bearing generates an abnormal noise, replace the bearing.
Motor coil insulation resistance	Every 6 months	Check the insulation resistance of the motor coil using a 500V megger. The insulation resistance should be 1 MΩ, dry the coil at 90°C or less in a drying furnace.

For "*" marked items, contact the sales outlet where purchased.

Note: 1) EM-A Motor is equipped with an internal magnet, and maintenance should therefore be performed only by Mitsubishi or by an authorized Mitsubishi service agent. Unauthorized disassembly could result in the permanent magnet rotor becoming stuck to other metal parts of the motor, making the maintenance task difficult, and possibly causing injuries. Moreover, a poor work environment could result in other metallic scraps and chips, etc., becoming adhered to the magnet, resulting in motor failure. Never attempt unauthorized motor modifications.

2) When oil oozes from set field of motor, if it does not develop, it can be used as it is because there is no problem on a performance. When oil poses a problem, use after wiping off oil. This oil is a grease ingredient applied to very small quantity at the time of the assembly in a factory.

3) The "years" periods indicated in parentheses are based on operation which occurs in an ambient temperature of 40°C, at the rated torque, for 300 days per year, 8 hours per day.

11. Troubleshooting

If the EM-A Motor has a problem, determine the cause and solve the problem while referring to the table below

Problem	Cause	Remedy
Non-rotating output shaft	(1)Inverter wiring fault, severed/disconnected wiring (2) Damaged gear or shaft.	(1)Check the power cable and the control cable wiring. (2)Replace the parts.
Extreme rise of temperature	(1)Overloaded operation. (2)The starting frequency is too high. (3)The ambient temperature is 40°C or above.	(1)Reduce the load by lowering the current to the rated current value. (2)Lower the frequency. (3)Ventilate the room to reduce the ambient temperature
Abnormal noise of motor	(1)Foreign material. (2)Damaged bearing.	(1)Remove the foreign material. (2)Replace the bearing.
Brake malfunction	(1)Foreign material on brake lining. (2)Abraded brake lining. (3)Seized brake coil. (4)Broken rectifier.	(1)Remove the foreign material. (2)Replace the entire brake unit. (3)Replace the entire brake unit. (4)Replace the rectifier.

Others	(1) Resonance is caused because the EM-A motor installation base is not rigid. (2) The vibration of machine is transferred to the EM-A motor to cause problem. (3) The eccentricity between the machine and the EM-A motor is too large.	(1) Increase the rigidity of the motor installation base (2) Increase the rigidity of the motor installation base. (3) Readjust the eccentricity to 0.05mm or less.
--------	--	---

12. Contact us

When you contact us, let us know the following items.

- | | | | |
|--|---|---------------------|--|
| (1) SERIAL No.
(2) Model number
(3) Output
(4) Reduction ratio or speed
(5) Motor voltage. | } | (See the nameplate) | (6) Part name
(7) Quantity
(8) Desired delivery date |
|--|---|---------------------|--|

【Warranty】

1. Warranty term and scope of warranty

When failure by the responsibility by the side of our company occurs for a product during the term of a warranty, our company will fix a product gratuitously through the store or the service company of our company which purchased. However, when the business trip repair to overseas from domestic is required, or when the business trip repair to the remote place according to a detached island and this is required, I do the cost price which engineer dispatch takes as onerousness.

【Warranty term】

The warranty term for the product shall be 18 months after the date of delivery or 12 month from the product starting operation, whether be shorter. Moreover, the term of warranty of a repair products does not become long more than the term of warranty before repair.

【Scope of warranty】

(1) Inspection

Please inspect your product by yourself. Our service personal, however, can inspect your product at your request with change to you. If a problem is detected by the inspection, we will discuss with you to determine whether we are responsible for the problem. If we are responsible for the problem, we will repair your product free of charge.

(2) Repair

In the following cases (i , ii , iii , iv , v , vi , vii , viii and ix) , we will charge the repair expense, parts replacement expense, and traveling expense to you. In the other cases, we will repair your product free of charge.

- i) The problem is caused due to inappropriate storage or handling of your product, carelessness, negligence , or operation in inappropriate facility or with inappropriate machine, etc.
- ii) The problem is caused because you have modified our product without our approval.
- iii) The problem is caused because you have used lubricating oil other than recommendation of our products.
- iv) The problem is caused because periodical inspection is not performed.
- v) The problem is caused because you have used our product while ignoring the product specifications.
- vi) The problem is caused because you have used accepted that the consumable parts (Bearing, oil seal, etc.) specified as the instructions manual etc. Even if it was a normal operating condition were able to protect when performed maintenance and inspection normally.
- vii) The problem is caused because natural disasters, such as an external factor by inevitability, such as a fire an unusual voltage, and an earthquake, thunder, and storm and flood damages.
- viii) The problem is caused because the reason which was not able to be foreseen with the level of the technology at the time of our company shipment.
- ix) Other cases where you are responsible for the problem.

These services are applied only in Japan. The foreign country is unavailable. We appreciate your understanding.

2. Exclusion

Even if a problem of our product causes damage of other manufacturers' machine, etc., we will not compensate any loss caused by the problem of our product or damaged other manufacturers' machines (loss of your company or your customer), even in the warranty period. Since it may change without a notice, please give beforehand the specification indicated to a catalog, an instructions manual, or technical data every knowledge.

3. Repair after stopping production

Even if production of the same model is stopped, we will repair your product for 7 years from the date of production stoppage. However, the parts manufactured by casting and mold have a case where allowed to consider it as the alternative parts which have the same function.

The product supply after production stoppage cannot respond including spare parts.

4. Change of Product specifications

Specifications listed in our catalogs, manuals or technical documents may be changed without notice.

5. Application and use of the Product

- (1) For the use of the product, its applications should be those that may not result in a serious damage even if any failure or malfunction occurs in the product, and a backup or fail-safe function should operate on an external system to the product when any failure or malfunction occurs.
- (2) The product is designed and manufactured as a general purpose product for use at general industries. Therefore, applications substantially influential on the public interest for such as atomic power plants and other power plants of electric power companies, and also which require a special quality assurance system, including applications for railway companies and government or public offices are not recommended, and we assume no responsibility for any failure caused by these applications when used. In addition, applications which may be substantially influential to human lives or properties for such as airlines, medical treatments, railway service, incineration and fuel systems, man-operated material handling equipment, entertainment machines, safety machines, etc. are not recommended, and we assume no responsibility for any failure caused by these applications when used. We will review the acceptability of the abovementioned applications, if you agree not to require a specific quality for a specific application. Please contact us for consultation.

13. Labeling (product name) based on the Marking for the Restriction of the Use of Certain Hazardous Substances in Electrical and Electronic Equipment: Geared Motor

(1) Marking for the Restriction of the Use of Certain Hazardous Substances in Electrical and Electronic Equipment



This mark indicates the environmental protection use period based on the Administrative Measure on the Restricted Use of Hazardous Substances in Electrical and Electronic Equipment applied to electrical and electronic equipment sold in China. To the extent that this product is used under the instructions on safety and usage, it will not cause any serious impact on the environment, human health, and properties for the indicated number of years from the manufacturing date.

Note:

When disposing of the product after proper use, follow local laws and regulations stipulating how to collect and recycle electrical and electronic devices.

Note: This symbol mark is for China only.

(2) Six hazardous substances, names of parts containing the substances, and the contents

The table below lists the six hazardous substances contained in this equipment, names of parts containing these substances, and the contents.

Names of hazardous substances contained in the equipment and the contents

Part Name	Hazardous Substances					
	Lead (Pb)	Mercury (Hg)	Cadmium (Cd)	Hexavalent chromium (Cr (VI))	Polybrominated biphenyls (PBB)	Polybrominated diphenyl ethers (PBDE)
Structural parts	×	○	○	○	○	○
Stator	○	○	○	○	○	○
Rotor	○	○	○	○	○	○
Brake	×	○	○	○	○	○
Detector	×	○	○	○	○	○

This table is prepared in accordance with the provisions of SJ/T 11364.

○ : Indicates that said hazardous substance contained in all of the homogeneous materials for this part is below the limit requirement of GB/T 26572.

× : Indicates that said hazardous substance contained in at least one of the homogeneous materials used for this part is above the limit requirement of GB/T 26572.

(1) 电器电子产品有害物质限制使用标识



根据《电器电子产品有害物质限制使用管理办法》，该标记适用于在中国销售的电器电子产品，其中的数字为产品的环保使用期限。只要遵守本产品在安全和使用方面的注意事项，在自生产日期算起的该年限内，将不会污染环境，也不会给人身和财产带来严重的影响。

(注) 产品正常使用终结废弃时，有关电子电气产品的回收、再利用等要遵守各自自治体的法律法规的要求。

Note: This symbol mark is for China only.

(2) 所含有的6种有害物质的名称, 含有量, 含有部品

本产品中所含有的6种有害物质的名称, 含有量, 含有部品如下表所示。

产品中有害物质的名称及含量

部件名称	有害物质					
	铅 (Pb)	汞 (Hg)	镉 (Cd)	六价铬 (Cr(VI))	多溴联苯 (PBB)	多溴二苯醚 (PBDE)
构造部件	×	○	○	○	○	○
转子	○	○	○	○	○	○
定子	○	○	○	○	○	○
制动器	×	○	○	○	○	○
检测器	×	○	○	○	○	○

本表格依据SJ/T11364的规定编制。

○: 表示该有害物质在该部件所有均质材料中的含量均在GB/T 26572规定的限量要求以下。

×: 表示该有害物质至少在该部件的某一均质材料中的含量超出GB/T26572规定的限量要求。

Inspection Certificate

Thank you for selecting a Mitsubishi Electric global PM motor.
This is to certify that your global PM motor has been
accepted by the specified inspection in our factory.

This document was issued in April 2024.
Note that product specifications may be subject to change without prior notice.

MITSUBISHI ELECTRIC FA INDUSTRIAL PRODUCTS CORPORATION