



INVERTER FR-D700

Safety stop function instruction manual

CONTENTS

1. General description	1
2. Installation and wiring	2
3. Example of safety system configuration	5
4. Test and checking failure	9
5. Safety parameters of FR-D700	10

Compliance with the EU Machinery Directive – Functional Safety

WARNING

Any misuse of safety function could lead to personal injury or death, property damage, or economic loss. To ensure that the system complies fully with requirement of safety, make a system-level risk assessment. Mitsubishi Electric Co. cannot assume responsibility for any system to comply with safety directive.

CAUTION

The information of this manual is merely a guide for proper installation. Mitsubishi Electric Co. cannot assume responsibility for the compliance or the noncompliance to any code, national, local or otherwise for the proper installation of this equipment. A hazard of personal injury and/or equipment damage exists if codes are ignored during installation.

WARNING

To avoid an electric shock hazard, verify that the voltage on the bus capacitors has discharged before performing any work on the drive. Measure the DC bus voltage at the P(+) and N(-) terminals or test points (refer to your drive's *User Manual* for locations and discharging time). The voltage must be zero.

WARNING

The safety stop function do not isolate electrically between drive and motor. To avoid an electric shock hazard, disconnect/isolate power to the drive and verify to ensure that the voltage is zero before performing any work on the motor (refer to your drive's *User Manual* for discharging time).

CAUTION

If you are using a FR-D740-EC with serial number shown below, safety function does not work according to safety standard. In such case please contact your sales person.

<Europe model : suffixed with '-EC'>

D740-012 to 080-EC : Axxxxx, Bxxxxx, Cxxxxx, Dxxxxx, Exxxx and Fxxxxx

D740-120 to 160-EC : Axxxxx, Bxxxxx, Cxxxxx and Dxxxxx

Check the SERIAL number indicated on the inverter rating plate or package.

Rating plate example

□	○	○	○○○○○○
Symbol	Year	Month	Control number
<hr/>			
SERIAL (Serial No.)			

The SERIAL consists of 1 version symbol, 2 numeric characters or 1 numeric character and 1 alphabet letter indicating year and month, and 6 numeric characters indicating control number. Last digit of the production year is indicated as the Year, and the Month is indicated by 1 to 9, X (October), Y (November), and Z (December).

1. General description

Features

Mitsubishi FR-D700 safety stop function prevents a drive from supplying rotational energy to motors. Dual safety channels 'S1' and 'S2' cut off the gate-drive power for IGBT to turn off.

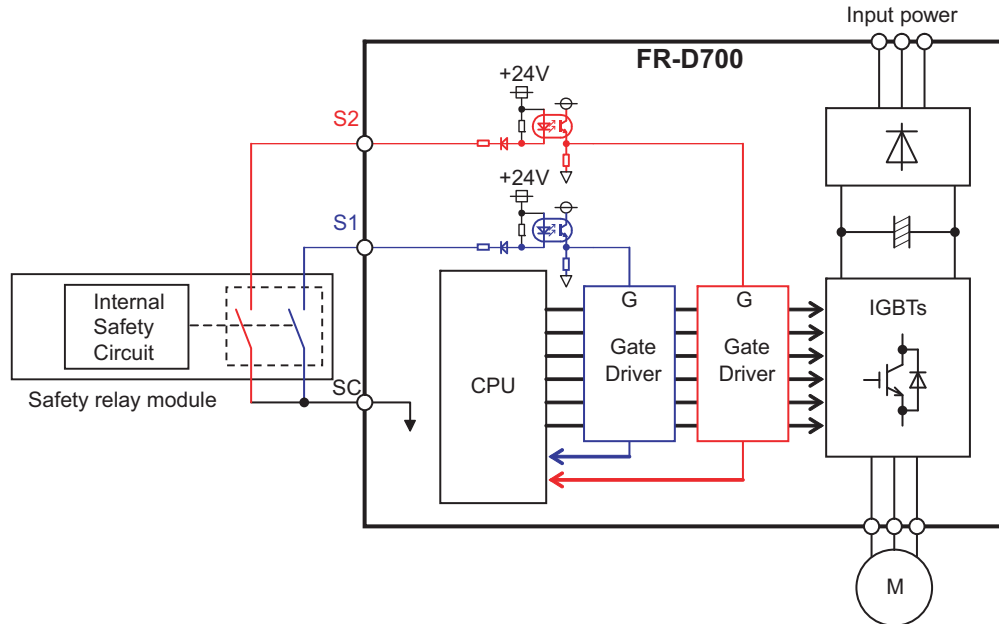

Fig.1 FR-D700 safety stop function diagram

WARNING

The safety stop function doesn't isolate electrically between drive and motor. To avoid an electric shock hazard, disconnect power to the drive and verify that the voltage is zero before performing any work on the motor (refer to your drive's *User Manual* for discharging time).

Directives

Mitsubishi FR-D700 safety stop function meets the following directives and categories.

ISO13849-1:2008 Category 3/PLd (applies to the FR-D700 manufactured in January 2012 or later)

IEC62061:2005 / IEC61800-5-2:2007 / IEC61508 SIL2

IEC60204-1:2006 / IEC61800-5-2:2007 Stop category 0

WARNING

The misuse of safety function leads to personal injury or death, property damage, or economic loss. To ensure that the system complies fully with requirement of safety, make a system-level risk assessment. Mitsubishi Electric Co. cannot assume responsibility for any system to comply with safety directive.

2. Installation and wiring

CAUTION

The following information is merely a guide for proper installation. Mitsubishi Electric Co. cannot assume responsibility for the compliance or the noncompliance to any code, national, local or otherwise for the proper installation of this equipment. A hazard of personal injury and/or equipment damage exists if codes are ignored during installation.

CAUTION

Ensure the safety relay unit and the FR-D700 unit is mounted closely in enclosure meeting IP54 and all interconnection wiring is short and protected against open and short circuit faults. Refer to EN/ISO13849-2.

Installation

Mitsubishi FR-D700 safety stop function should be used under following condition and environment.

Table.1 The condition and environment for using safety stop function

Item		Condition
Temperature range	Operation	-10°C to +50°C (non-freezing)
	Storage	-20°C to +65°C
Ambient humidity		90%RH maximum (non-condensing)
Vibration		5.9m/s ² or less
Altitude		maximum 1000m above sea level
Atmosphere		Indoors (without corrosive gas, flammable gas, oil mist, dust and dirt etc.)
Over voltage category		II or less
Pollution degree		II or less
Mounting		wall mounting / vertical orientation

CAUTION

In order to meet safety stop standards, an approved safety relay unit to ISO13849-1/EN954-1 safety category 3 or better shall be used in conjunction with FR-D700 as shown in example1 or 2. In addition, all other components with in the safety stop loop shall be 'safety approved' types.

WARNING

To avoid an electric shock hazard, insert the magnetic contactor (MC) between power source and drive. Open the contact of MC and keep away from drive for discharging time (refer to your drive's *User Manual* for information) before performing any work on the drive. Verify that the voltage on the bus capacitors has discharged before measuring the DC bus voltage at the P(+) and N(-) terminals or test points (refer to your drive's *User Manual* for locations). The voltage must be zero.

CAUTION

To avoid systematic faults, a test to check the operation of the safety function has to be performed in order to check the correct function of the monitor signal. This test shall be carried out at system installation, any software changes, parameterization changes, and/or at least once per year. Refer to '4. Test and checking failure'.

Wiring

The safety related terminals are described in Table.2 and Table.3

Table.2 The safety related terminals

Terminal Symbol	Description	Rating
S1	For input of safety stop channel1. S1-SC is Open: In safety stop mode. Short: Non safety stop mode.	Input resistance:4.7kΩ Current : 4 to 6 mA (In case of shorted to SC) Voltage : 21 to 26 V (In case of open from SC)
S2	For input of safety stop channel2. S2-SC is Open: In safety stop mode. Short: Non safety stop mode.	
SO (SAFE)	As output for safety stop condition. SO terminal type is 'Open collector output'. SO-SC is OFF(Open): Drive enabled, or drive shutoff (with internal circuit fault) ON(Close): Drive shutoff (no internal circuit fault) Important: SO terminal should be used for monitoring safety stop condition only. SO terminal cannot be used for safety function.	Load: 24VDC/0.1A max. Voltage drop: 3.4V max. (In case of 'ON' state)
SC	Common terminal for S1, S2, SO terminals. *SC is connected terminal SD internally.	
RUN (SAFE2)	As output for failure detection and alarm. RUN terminal type is 'Open collector output'. RUN-SE is OFF(Open): Detect failure or Alarm. ON(Close): No failure detected. Attention: To use RUN terminal for monitor output of failure detection, Pr.190 should be set to "81" (Safety monitor 2). Note: This terminal can be used for alarm or to prevent restart only, no other safety function.	Load: 24VDC/0.1A max. Voltage drop: 3.4V max. (In case of 'ON' state)
SE	Common terminal for safety RUN terminal.	
A,C (SAFE2)	As output for failure detection. A,C terminal type is 'Relay output'. A-C is OFF(Open): Detect failure or Alarm. ON(Close): No failure detected. Attention: To use A,C terminal for monitor output of failure detection, Pr.192 should be set to "81" (Safety monitor "2"). Note: This terminal can be used for alarm or to prevent restart only, no other safety function.	Load: 30VDC/0.3A max.
SD	Signal ground	

Table.3 Truth table of Safety related signals

Input power	S1-SC	S2-SC	Internal safety circuit fault *1	SO (SAFE)	RUN or A-C (SAFE2) *2 *3	Drive state
OFF	-	-	-	OFF(Open)	OFF(Open)	Drive shutoff (Safe state)
ON	Short	Short	No failure	OFF(Open)	ON(Close)	Drive enable
			Detected	OFF(Open)	OFF(Open)	Drive shutoff (Safe state)
	Open	Open	No failure	ON(Close)	ON(Close)	Drive shutoff (Safe state)
			Detected	OFF(Open)	OFF(Open)	Drive shutoff (Safe state)
	Short	Open	N/A	OFF(Open)	OFF(Open)	Drive shutoff (Safe state)
	Open	Short	N/A	OFF(Open)	OFF(Open)	Drive shutoff (Safe state)

" N/A " denotes a condition where circuit fault does not apply.

*1 At an internal safety circuit fault, E.SAF or E.CPU is displayed on the operation panel. SA is displayed on the operation panel while S1 and S2 signals are both open and the safety function operates (without internal safety circuit fault).

*2 To use RUN terminal for monitor output of failure detection, Pr.190 should be set to "81" (Safety monitor 2).

*3 To use A,C terminal for monitor output of failure detection, Pr.192 should be set to "81" (Safety monitor 2).

Wire and ferrule specification

Table.4 wire and ferrule specification

Wire size (mm ²)	Ferrule with insulation collar *	Crimping tool *
0.3 / 0.5	AI 0,5-10WH	CRIMPFOX 6
0.75	AI 0,75-10GY	
1	AI 1-10RD	
1.25 / 1.5	AI1,5-10BK	
0.75 (combined 2 wire)	AI TWIN 2 X 0,75-10GY	

*Ferrules and tools are distributed by Phoenix Contact.

Jumper cable

The jumper cable between S1,S2 and SC terminal has been installed in the factory as shown in Fig.2.

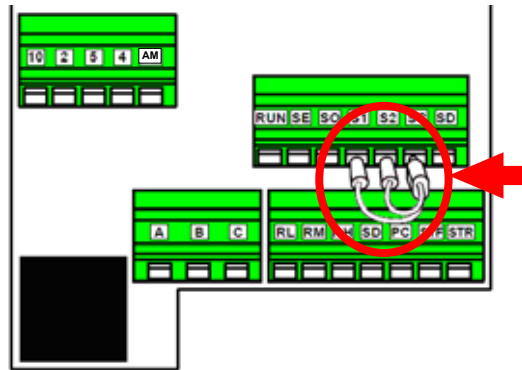

Fig.2. Short wire

Before connecting safety input wire to S1,S2 and SC terminal, remove this jumper cable.

3. Example of safety system configuration

Example 1

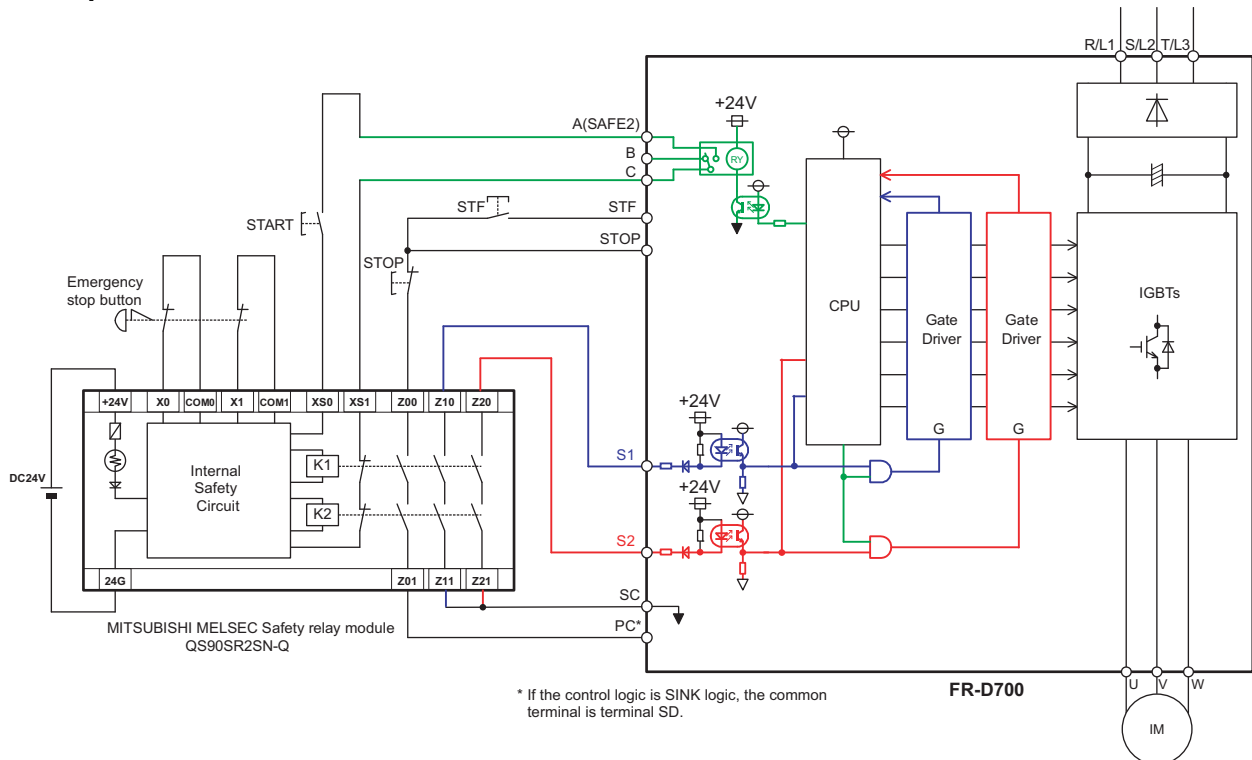

Fig.3 Safety system example 1 – STOP asynchronous with emergency stop button and fault detection through A-C output.

For safety stop, configure the wiring as shown in Fig.3 above.



NOTE

- The above wiring is configured to prevent restart in case of a fault.
- Pr.192 (A,B,C terminal function selection) must be set to "81". This setting makes the A-C output to open in case of failure.
- After the power-up of the system, to reset the safety stop mode, press the START switch, and also press the STF switch, then start the motor rotation.
- In the above configuration, after reset of emergency stop button, drive will be in safe-state until START switch is pressed.

CAUTION

To prevent restart in case of recovering from input power loss of drive, 3-wired connection for STF/STOP control is recommended.

In case of 2-wire connection and using latching type switch to short between STF and SD/PC for starting, ensure the compliance with safety requirement for the restarting when the drive recover from input power loss.

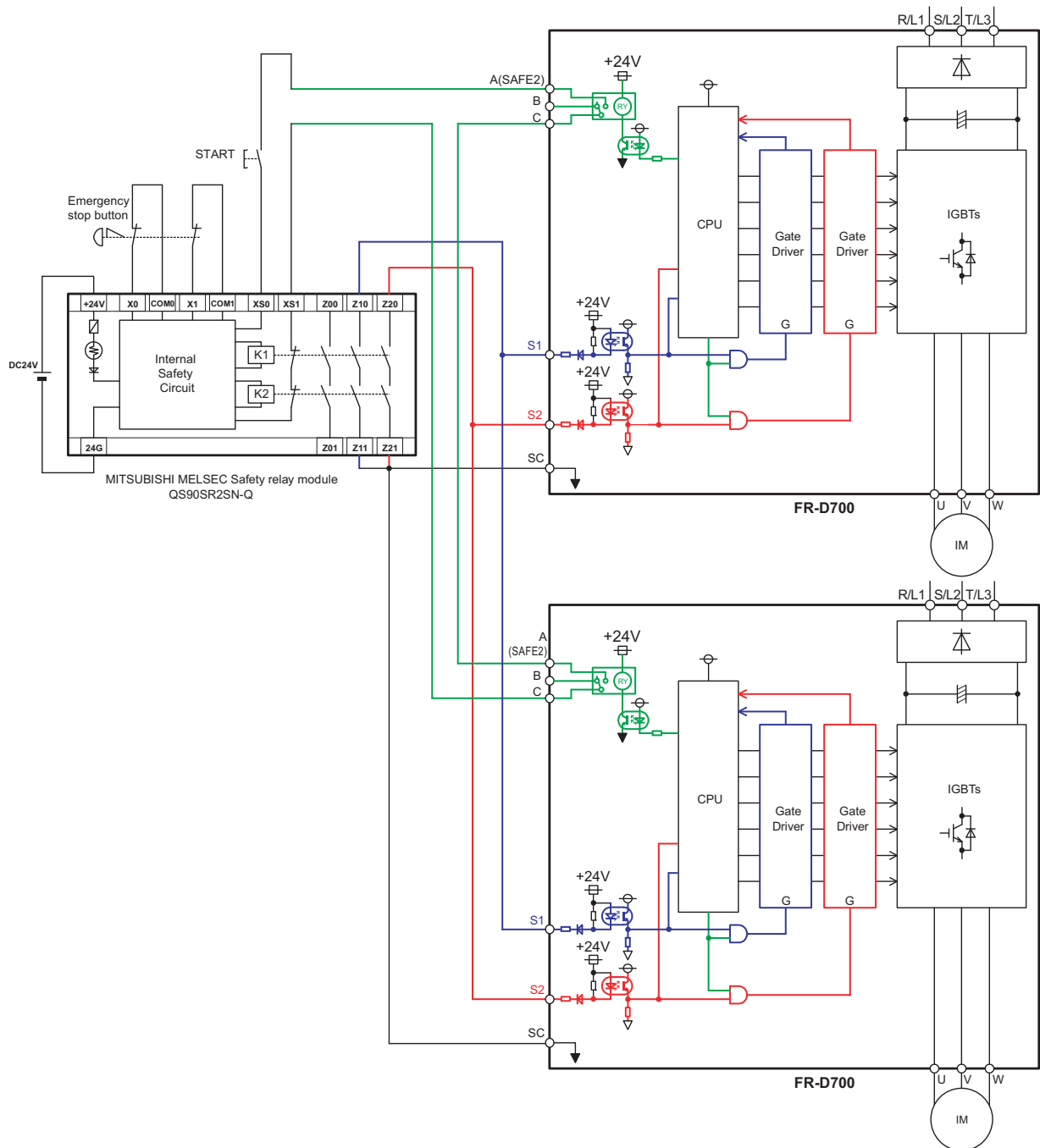

Fig.4 Example when using multiple FR-D740-EC inverters manufactured in August 2010 or later for the safety stop function



NOTE

- **For Europe model:**
 When using the safety stop function, do not connect the FR-D700 series manufactured in July 2010 or before together with the one manufactured in August 2010 or later. If connected together, the safety stop function may not work properly.
 When the FR-D700 series manufactured in July 2010 or before must be used together, connect an electronic component (diode) to the inverter output shutoff signals (terminal S1 and S2).
- **For Japan model:**
 When using the safety stop function, do not connect the FR-D700 series manufactured in December 2010 or before together with the one manufactured in January 2011 or later. If connected together, the safety stop function may not work properly.
 When the FR-D700 series manufactured in December 2010 or before must be used together, connect an electronic component (diode) to the inverter output shutoff signals (terminal S1 and S2). Refer to page 7 for the specification of the diode.
- Do not connect the FR-E700-SC/NC/NF series together with the FR-D700 series. If connected together, the safety stop function does not work properly.

- Example when using multiple FR-D700 inverters manufactured in December 2010 or before

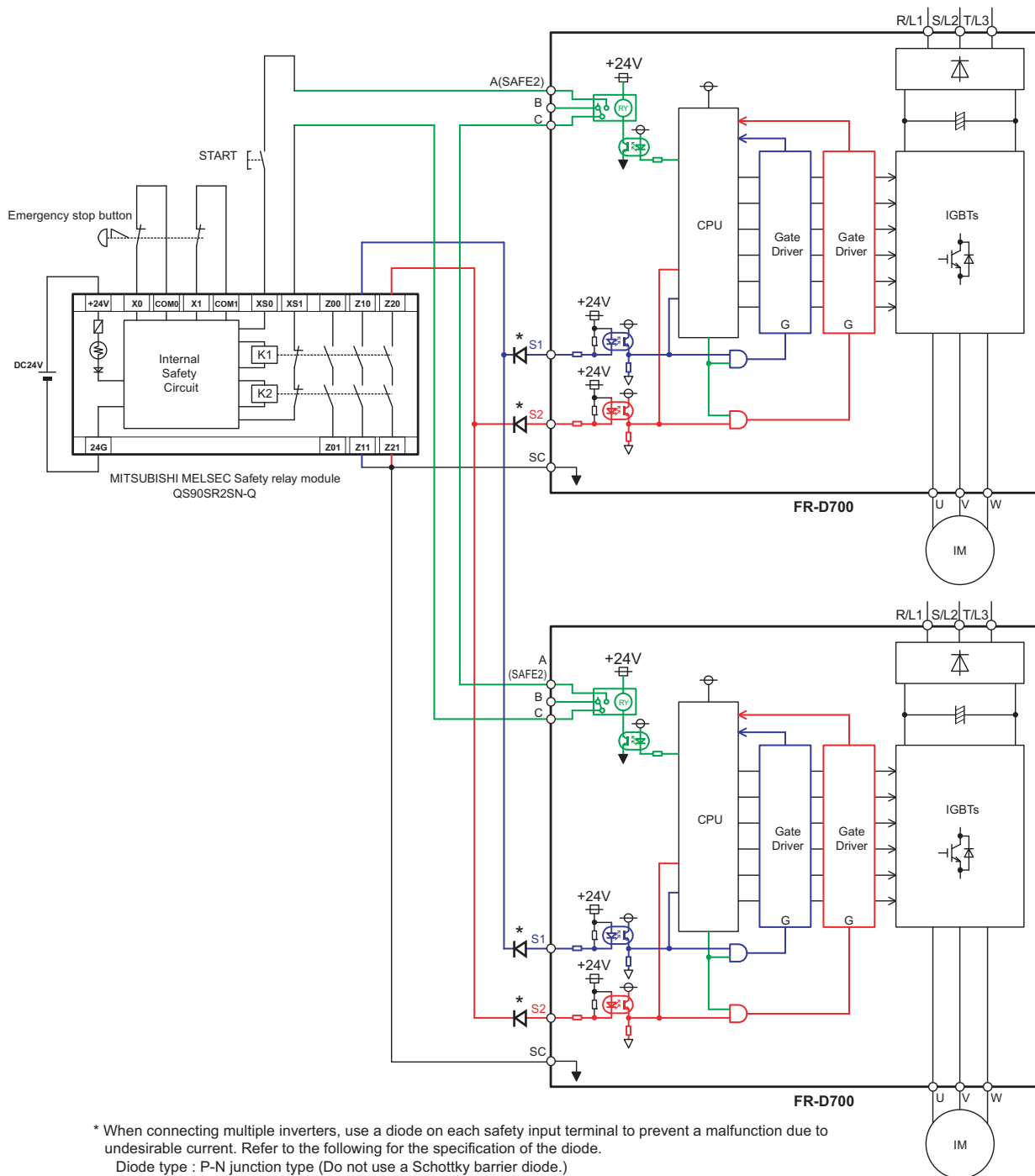

Fig.5 Example of multiple inverters connected to a safety relay unit



NOTE

- The number of inverters connected to a safety relay unit should be decided under considerations of output terminal rating of a safety relay unit.
- Do not connect the FR-E700-SC/NC/NF series together with the FR-D700 series. If connected together, the safety stop function does not work properly.

Example 2

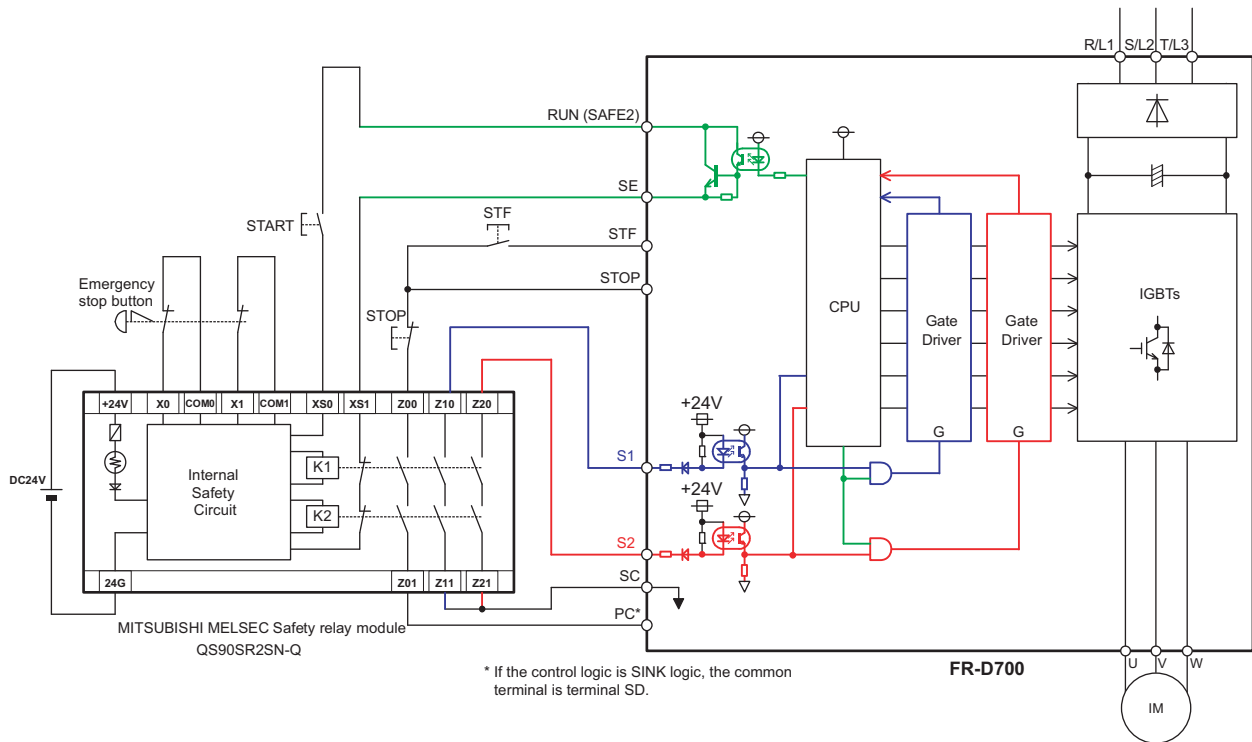

Fig.6 Safety system example 2 – STOP synchronous with emergency stop button and fault detection through RUN output.

For safety stop, configure the wiring as shown in Fig.6 above.



NOTE

- XS0 should be connected to RUN terminal and XS1 should be connected to SE, because polarity of XS0 is positive, XS1 is negative.
- Pr.190 (RUN terminal function selection) must be set to "81". This setting makes the RUN output to turn off in case of failure.
- The above wiring is configured to prevent restart in case of a fault.
- In the event of reset of 'safe-condition' the motor rotation will not occur until STF is pressed. (for normal 'non-safety' STF/STOP function, please refer to your drive's *User Manual*)
- After the power-up of the system, to reset the safety stop mode, press the START switch, and also press the STF switch, then start the motor rotation.

CAUTION

To prevent restart in case of recovering from input power loss of drive, 3-wired connection for STF/STOP control is recommended.

In case of 2-wire connection and using latching type switch to short between STF and SD/PC for starting, ensure the compliance with safety requirement for the restarting when the drive recover from input power loss.

4. Test and checking failure

CAUTION						
To avoid systematic faults, a test even for faulty demands of the safety function has to be performed in order to check the correct function of the monitor signal. This test shall be carried out at system installation, any software changes, parameterization changes, and/or at least once per year.						

I/O status and failure

FR-D700 safety related I/O status obeys the following truth table.

Table.5 Truth table of Safety related signals

Input power	S1-SC	S2-SC	Internal safety circuit fault *1	SO (SAFE)	RUN or A-C (SAFE2) *2 *3	Drive state
OFF	-	-	-	OFF(Open)	OFF(Open)	Drive shutoff (Safe state)
ON	Short	Short	No failure	OFF(Open)	ON(Close)	Drive enable
			Detected	OFF(Open)	OFF(Open)	Drive shutoff (Safe state)
	Open	Open	No failure	ON(Close)	ON(Close)	Drive shutoff (Safe state)
			Detected	OFF(Open)	OFF(Open)	Drive shutoff (Safe state)
	Short	Open	N/A	OFF(Open)	OFF(Open)	Drive shutoff (Safe state)
	Open	Short	N/A	OFF(Open)	OFF(Open)	Drive shutoff (Safe state)

" N/A " denotes a condition where circuit fault does not apply.

*1 At an internal safety circuit fault, E.SAF or E.CPU is displayed on the operation panel. SA is displayed on the operation panel while S1 and S2 signals are both open and the safety function operates (without internal safety circuit fault).

*2 To use RUN terminal for monitor output of failure detection, Pr.190 should be set to "81" (Safety monitor 2).

*3 To use A,C terminal for monitor output of failure detection, Pr.192 should be set to "81" (Safety monitor 2).

In case of diagnostic or functionality test, check the I/O state whether it is same or not as Table.5.

Diagnostic

If the failure detected, FR-D700 output alarm signal and indicate 'E.SAF' at the display.

In case of FR-D700 output the alarm, please take following action.

- (1) Check the S1-SC and S2-SC input signal logic is the same. If these are different logic, correct the input signal and reset the FR-D700.
- (2) Disconnect the wire from S1, S2, SC terminal, then reset or power-off and on, If the 'SA' letter is flashed up at display, there is failure in system except FR-D700. But, still 'E.SAF' is displayed and alarm output, there is malfunction on FR-D700.

Self diagnostic test

FR-D700 does the self-diagnostic test on the power-ON.

If FR-D700 output alarm at power-ON, please take the action described in 'Diagnostic' at above.

Test procedure for functionality

As depicted 'ATTENTION' in above, the test for the functionality is important.

Please do the test following procedure.

- (1) Please make each state of S1-SC and S2-SC depicted at Table.5.
- (2) If there is any different state from Table.5, FR-D700 has some malfunction.
- (3) If there is no different state from Table.5, check the systematic performance, such as, press the Emergency switch, press the start/restart button at the failure detected (RUN-SE opened), and so on.
- (4) Finally clear the error record of the FR-D700 (see the user manual how to clear the error record).

5. Safety parameters of FR-D700

FR-D700 safety related I/O status obeys the following truth table.

Table.6 Safety parameters of FR-D700

Parameter	Value
PFD _{AVG}	1.23×10^{-4}
PFH _D	1.41×10^{-9}
PL	d
MTTF _D	991 years
DC _{AVG}	60%

REVISIONS

Print Date	Manual Number	Revision
Aug. 2009	BCN-A211508-000-C	First edition
Dec. 2009	BCN-A211508-000-D	Modification Example of Safety stop connection
Jan. 2010	BCN-A211508-000-E	Addition Diode specification for multiple connection
Jul. 2010	BCN-A211508-000-F	Addition Example of multiple connection
Jan. 2012	BCN-A211508-000-G	Modification Conformance to ISO13849-1
Jul. 2013	BCN-A211508-000-H	Addition Contact information on the back cover
Sep. 2015	BCN-A211508-000-J	Modification Safety parameters

HEADQUARTERS

MITSUBISHI ELECTRIC EUROPE
EUROPE B.V.
German Branch
Gothaer Straße 8
D-40880 Ratingen
Phone: +49 (0) 21 02 / 486-0
Hotline: +49 2102 1805 000-765 /-766
Fax: +49 (0) 21 02 / 4 86-1 12 0
e mail: megfa-mail@meg.mee.com
www.mitsubishi-automation.com

MITSUBISHI ELECTRIC FRANCE
FRANCE
25, Boulevard des Bouverts
F-92741 Nanterre Cedex
Phone: +33 1 55 68 55 68
Fax: +33 1 49 01 07 25
e mail: factory.automation@fra.mee.com

MITSUBISHI ELECTRIC ITALY
EUROPE B.V.
Italian Branch
C.D. Colleoni-P. Perseo Ing. 2
Via Paracelso 12
I-20041 Agrate Brianza (MI)
Phone: +39 (0) 39 / 60 53 1
Fax: +39 (0) 39 / 60 53 312
e mail: factory.automation@it.mee.com

MITSUBISHI ELECTRIC SPAIN
EUROPE B.V.
Pol. Ind. Can Magi-C.
Calle Joan Buscallá, 2-4 AC 420
E-08190 Sant Cugat del Valles
Phone: +34 (9) 3 / 565 31 31
Fax: +34 (9) 3 / 589 29 48

MITSUBISHI ELECTRIC UK
EUROPE B.V.
UK Branch
Travellers Lane
Hatfield, Hertfordshire, AL10 8 XB
Phone: +44 (0) 1707 / 27 61 00
Fax: +44 (0) 1707 / 27 86 95

MITSUBISHI ELECTRIC JAPAN
CORPORATION
Tokyo Bldg.
2-7-3 Marunouchi Chiyoda-Ku
Tokyo 100-8310
Phone: +81 (0) 3 / 32 18 31 76
Fax: +81 (0) 3 / 32 18 24 22

MITSUBISHI ELECTRIC USA
AUTOMATION
500 Corporate Woods Parkway
Vernon Hills, Illinois 60061
Phone: +1 (0) 847 / 478 21 00
Fax: +1 (0) 847 / 478 03 27

INDIA REPRESENTATIVES

MITSUBISHI ELECTRIC INDIA
PVT. LTD.
Tower A&B, DLF Cyber Greens,
DLF Cyber City, DLF Phase III,
Gurgaon - 122002 Haryana
Phone: +91 (0) 124 4630 300
Fax: +91 (0) 124 4630 399

MITSUBISHI ELECTRIC INDIA
India Factory Automation Centre
EL-3, J block, M.I.D.C. Bhosari
Pune - 411026 Maharashtra
Phone: +91 (0) 20 2710 2000
Fax: +91 (0) 20 2710 2100

EUROPEAN REPRESENTATIVES

GEVA AUSTRIA
Wiener Straße 89
A-2500 Baden
Phone: +43 (0) 2252 / 85 55 20
Fax: +43 (0) 2252 / 488 60
e mail: office@geva.co.at

Getronics b.v. BELGIUM
Control Systems
Pontbeeklaan 43
B-1731 Asse-Zellik
Phone: +32 (0) 2 / 4 67 17 51
Fax: +32 (0) 2 / 4 67 17 45
e mail: infoautomation@getronics.com

TELECON CO. BULGARIA
4, A. Ljapchev Blvd.
BG-1756 Sofia
Phone: +359 92 / 97 44 05 8
Fax: +359 92 / 97 44 06 1
e mail: ———

AutoCont CZECHIA
Control Systems s.r.o.
Nemocnicni 12
CZ-70200 Ostrava 2
Phone: +420 (0) 69 / 615 21 11
Fax: +420 (0) 69 / 615 21 12
e mail: ———

louis poulsen DENMARK
industri & automation
Geminivej 32
DK-2670 Greve
Phone: +45 (0) 43 / 95 95 95
Fax: +45 (0) 43 / 95 95 91
e mail: lpia@lpmail.com

UTU Elektrotehnika AS ESTONIA
Pärnu mnt. 160i
EE-10621 Tallinn
Phone: +372 6 / 51 72 80
Fax: +372 6 / 51 72 88
e mail: utu@utu.ee

URHO TUOMINEN OY FINLAND
Hevoshaankatu 3
FIN-28600 Pori
Phone: +358 (0) 2 / 55 08 00
Fax: +358 (0) 2 / 55 088 41
e mail: ———

UTECO A.B.E.E. GREECE
5, Mavrogenous Str.
GR-18542 Piraeus
Phone: +30 (0) 1 / 42 10 050
Fax: +30 (0) 1 / 42 12 033
e mail: uteco@uteco.gr

EUROPEAN REPRESENTATIVES

MITSUBISHI ELECTRIC IRELAND
EUROPE B.V.-Irish Branch
Westgate Business Park
Ballymount
IRL-Dublin 24
Phone: +353 (0) 1 / 419 88 00
Fax: +353 (0) 1 / 419 88 90
e mail: sales.info@meuk.mee.com

ALFATRADE LTD. MALTA
99 Paola Hill
Paola PLA 08
Phone: +356 / 697816
Fax: +356 / 697817
e mail: paul.licari@alfatrx.com

Getronics bv NETHERLANDS
Control Systems
Donauweg 10
NL-1043 AJ-Amsterdam
Phone: +31 (0) 20 / 586 15 92
Fax: +31 (0) 20 / 586 19 27
e mail: infoautomation@getronics.com

Beijer Electronics AS NORWAY
Teglverksveien 1
N-3002 Drammen
Phone: +47 (0) 32 / 24 30 00
Fax: +47 (0) 32 / 84 85 77
e mail: ———

MPL Technology SP.Z.o.o POLAND
ul.Wroclawska 53
PL-30-011 Kraków
Phone: +48 (0) 12 / 632 28 85
Fax: +48 (0) 12 / 632 47 82
e mail: krakow@mpl.com.pl

Sirius Trading&Services srl ROMANIA
Bd. Ghica nr. 112, Bl. 41
RO-72335 Bucuresti 2
Phone: +40 (0) 1 / 210 55 11
Fax: +40 (0) 1 / 210 55 11
e mail: sirius_t_s@fx.ro

ACP AUTOCOMP a.s. SLOVAKIA
Chalupkova 7
SK-81109 Bratislava
Phone: +421 (0) 7 592 22 54
Fax: +421 (0) 7 592 22 48
e mail: ———

INEA d.o.o. SLOVENIA
Ljubljanska 80
SI-1230 Domžale
Phone: +386 (0) 17 21 80 00
Fax: +386 (0) 17 24 16 72
e mail: inea@inea.si

EUROPEAN REPRESENTATIVES

Beijer Electronics AB SWEDEN
Box 426
S-20123 Malmö
Phone: +46 (0) 40 / 35 86 00
Fax: +46 (0) 40 / 93 23 02
e mail: ———

ECONOTEC AG SWITZERLAND
Postfach 282
CH-8309 Nürensdorf
Phone: +41 (0) 1 / 838 48 11
Fax: +41 (0) 1 / 838 48 12
e mail: ———

GTS TURKEY
Darülaceze Cad. No. 43A KAT: 2
TR-80270 Okmeydani-Istanbul
Phone: +90 (0) 212 / 320 1640
Fax: +90 (0) 212 / 320 1649
e mail: ———

EURASIAN REPRESENTATIVES

MITSUBISHI ELECTRIC RUSSIA
EUROPE B.V.
12/1 Goncharnaya St, suite 3C
RUS-109240 Moskow
Phone: +7 (0) 95 / 915-8624/02
Fax: +7 (0) 95 / 915-8603
e mail: ———

STC Drive Technique RUSSIA
Poslannikov per., 9, str. 1
RUS-107005 Moskow
Phone: +7 (0) 95 / 786 21 00
Fax: +7 (0) 95 / 786 21 01
e mail: ———

JV-CSC Automation UKRAINE
15, M. Raskovoyi St., Floor 10,
Office 1010
U-02002 Kiev
Phone: +380 (4) 4 / 238 83 16
Fax: +380 (4) 4 / 238 83 17
e-Mail: mkl@csc-a.kiev.ua

MIDDLE EAST REPRESENTATIVE

SHERF Motion Techn. LTD ISRAEL
Rehov Hamerkava 19
IL-58851 Holon
Phone: +972 (0) 3 / 559 54 62
Fax: +972 (0) 3 / 556 01 82
e mail: ———

MITSUBISHI ELECTRIC CORPORATION

HEAD OFFICE: TOKYO BUILDING 2-7-3, MARUNOUCHI, CHIYODA-KU, TOKYO 100-8310, JAPAN