

Mitsubishi Electric Industrial Robot

RH-FRH Series Standard Specifications Manual

- RH-3FRH series
- RH-6FRH series
- RH-12FRH series
- RH-20FRH series
- RH-3FRHR series

SAFETY PRECAUTIONS

Read the separate Safety Manual thoroughly before using this product. Take precautions as necessary.

Before using this product, please read this manual and the relevant manuals carefully and pay full attention to safety to handle the product correctly.

The precautions given in this manual are concerned with this product only. For the safety precautions of the robot system, refer to the user's manual for the peripheral equipment used.

In this manual, the safety precautions are classified into three levels: "⚠️ DANGER", "⚠️ WARNING", and "⚠️ CAUTION".

⚠️ DANGER	Precaution indicating cases where there is a risk of operator fatality or serious injury if handling is mistaken. Always observe these precautions to safely use the robot.
⚠️ WARNING	Precaution indicating cases where the operator could be subject to fatalities or serious injuries if handling is mistaken. Always observe these precautions to safely use the robot.
⚠️ CAUTION	Precaution indicating cases where operator could be subject to injury or physical damage could occur if handling is mistaken. Always observe these precautions to safely use the robot.

Under some circumstances, failure to observe the precautions given under "⚠️ CAUTION" may lead to serious consequences.

Observe the precautions of all the levels because they are important for personal and system safety.

Make sure that the end users read this manual and then keep the manual in a safe place for future reference.

A. These show precautions based on the Ordinance on Industrial Safety and Health (Articles 36, 104, 150, 151)

⚠️ DANGER
<ul style="list-style-type: none">● Provide a fence or enclosure during operation to prevent contact of the operator and robot. →Installation of safety fence
⚠️ WARNING
<ul style="list-style-type: none">● Prepare a device that allows operation to be stopped immediately during teaching work. (This also applies to maintenance work with the power source turned ON.) →Setting of emergency stop switch

CAUTION

- All teaching work must be carried out by an operator who has received special training. (This also applies to maintenance work with the power source turned ON.)
 - Enforcement of safety training
 - For teaching work, prepare a work plan related to the methods and procedures of operating the robot, and to the measures to be taken when an error occurs or when restarting. Carry out work following this plan. (This also applies to maintenance work with the power source turned ON.)
 - Preparation of work plan
 - During teaching work, place a sign indicating that teaching work is in progress on the start switch, etc. (This also applies to maintenance work with the power source turned ON.)
 - Indication of teaching work in progress
 - Establish a set signaling method to the related operators for starting work, and follow this method.
 - Signaling of operation start
 - As a principle turn the power OFF during maintenance work. Place a sign indicating that maintenance work is in progress on the start switch, etc.
 - Indication of maintenance work in progress
 - Before starting work, inspect the robot, emergency stop switch and other related devices, etc., and confirm that there are no errors.
 - Inspection before starting work
-

B. This shows precaution points given in the "Safety Manual".

For details, please read the text of the "Safety Manual".

DANGER

- When automatic operation of the robot is performed using multiple control devices (GOT, programmable controller, push-button switch), the interlocking of operation rights of the devices, etc. must be designed by the customer.
 - Do not connect the Handy GOT when using the GOT direct connection function of this product. Failure to observe this may result in property damage or bodily injury because the Handy GOT can automatically operate the robot regardless of whether the operation rights are enabled or not.
 - Do not connect the Handy GOT to a programmable controller when using an iQ Platform compatible product with the CR860-R/CR860-Q controller. Failure to observe this may result in property damage or bodily injury because the Handy GOT can automatically operate the robot regardless of whether the operation rights are enabled or not.
 - Do not remove the SSCNET III cable while power is supplied to the multiple CPU system or the servo amplifier. Do not look directly at light emitted from the tip of SSCNET III connectors or SSCNET III cables of the Motion CPU or the servo amplifier. Eye discomfort may be felt if exposed to the light. (Reference: SSCNET III employs a Class 1 or equivalent light source as specified in JIS C 6802 and IEC 60825-1 (domestic standards in Japan).)
 - Do not remove the SSCNET III cable while power is supplied to the controller. Do not look directly at light emitted from the tip of SSCNET III connectors or SSCNET III cables. Eye discomfort may be felt if exposed to the light. (Reference: SSCNET III employs a Class 1 or equivalent light source as specified in JIS C 6802 and IEC 60825-1 (domestic standards in Japan).)
 - Attach the cap to the SSCNET III connector after disconnecting the SSCNET III cable. If the cap is not attached, dirt or dust may adhere to the connector pins, resulting in deterioration connector properties, and leading to malfunction.
-

WARNING

- Securely install the hand and tool, and securely grasp the workpiece. Failure to observe this could lead to personal injuries or damage if the object comes off or flies off during operation.
 - Securely ground the robot and controller. Failure to observe this could lead to malfunctioning by noise or to electric shock accidents.
 - When carrying out teaching work in the robot's movement range, always secure the priority right for the robot control. Failure to observe this could lead to personal injuries or damage if the robot is started with external commands.
 - When the robot arm has to be moved by hand from an external area, do not place hands or fingers in the openings. Failure to observe this could lead to hands or fingers catching depending on the posture.
-

CAUTION

- Use the robot within the environment given in the specifications.
Failure to do so could lead to a drop or reliability or faults.
(Temperature, humidity, atmosphere, noise environment, etc.)
 - Transport the robot with the designated transportation posture.
Transporting the robot in a non-designated posture could lead to personal injuries or faults from dropping.
 - Always use the robot installed on a secure table.
Use in an instable posture could lead to positional deviation and vibration.
 - Wire the cable as far away from noise sources as possible.
If placed near a noise source, positional deviation or malfunction could occur.
 - Do not apply excessive force on the connector or excessively bend the cable.
Failure to observe this could lead to contact defects or wire breakage.
 - Make sure that the workpiece weight, including the hand, does not exceed the rated load or tolerable torque. Exceeding these values could lead to errors or faults.
 - Indicate the operation state during robot operation. Failure to indicate the state could lead to operators approaching the robot or to incorrect operation.
 - Keep the jog speed as low as possible, and always watch the robot. Failure to do so could lead to interference with the workpiece or peripheral devices.
 - After editing the program, always confirm the operation with step operation before starting automatic operation. Failure to do so could lead to interference with peripheral devices because of programming mistakes, etc.
 - Make sure that if the safety fence entrance door is opened during automatic operation, the door is locked or that the robot will automatically stop. Failure to do so could lead to personal injuries.
 - Never carry out modifications based on personal judgments, or use non-designated maintenance parts.
Failure to observe this could lead to faults or failures.
 - Do not stop the robot or apply emergency stop by turning the robot controller's main power OFF. If the robot controller main power is turned OFF during automatic operation, the robot accuracy could be adversely affected. Moreover, it may interfere with the peripheral device by drop or move by inertia of the arm.
 - Do not turn off the main power to the robot controller while rewriting the internal information of the robot controller such as the program or parameters. If the main power to the robot controller is turned off while in automatic operation or rewriting the program or parameters, the internal information of the robot controller may be damaged.
 - Make sure there are no mistakes in the wiring. Connecting differently to the way specified in the manual can result in errors, such as the emergency stop not being released. In order to prevent errors occurring, please be sure to check that all functions (such as the teaching box emergency stop, customer emergency stop, and door switch) are working properly after the wiring setup is completed.
 - Use the network equipments (personal computer, USB hub, LAN hub, etc) confirmed by manufacturer. The thing unsuitable for the FA environment (related with conformity, temperature or noise) exists in the equipments connected to USB. When using network equipment, measures against the noise, such as measures against EMI and the addition of the ferrite core, may be necessary. Please fully confirm the operation by customer. Guarantee and maintenance of the equipment on the market (usual office automation equipment) cannot be performed.
-

CAUTION

- To maintain the security (confidentiality, integrity, and availability) of the robot and the system against unauthorized access, DoS^{*1} attacks, computer viruses, and other cyberattacks from unreliable networks and devices via network, take appropriate measures such as firewalls, virtual private networks (VPNs), and antivirus solutions. Mitsubishi Electric shall have no responsibility or liability for any problems involving robot trouble and system trouble by unauthorized access, DoS attacks, computer viruses, and other cyberattacks.

^{*1} DoS: A denial-of-service (DoS) attack disrupts services by overloading systems or exploiting vulnerabilities, resulting in a denial-of-service (DoS) state.

CR800 controller

Notes of the basic component are shown.

⚠ CAUTION

Please install the earth leakage breaker in the primary side power supply of the controller because of leakage protection.

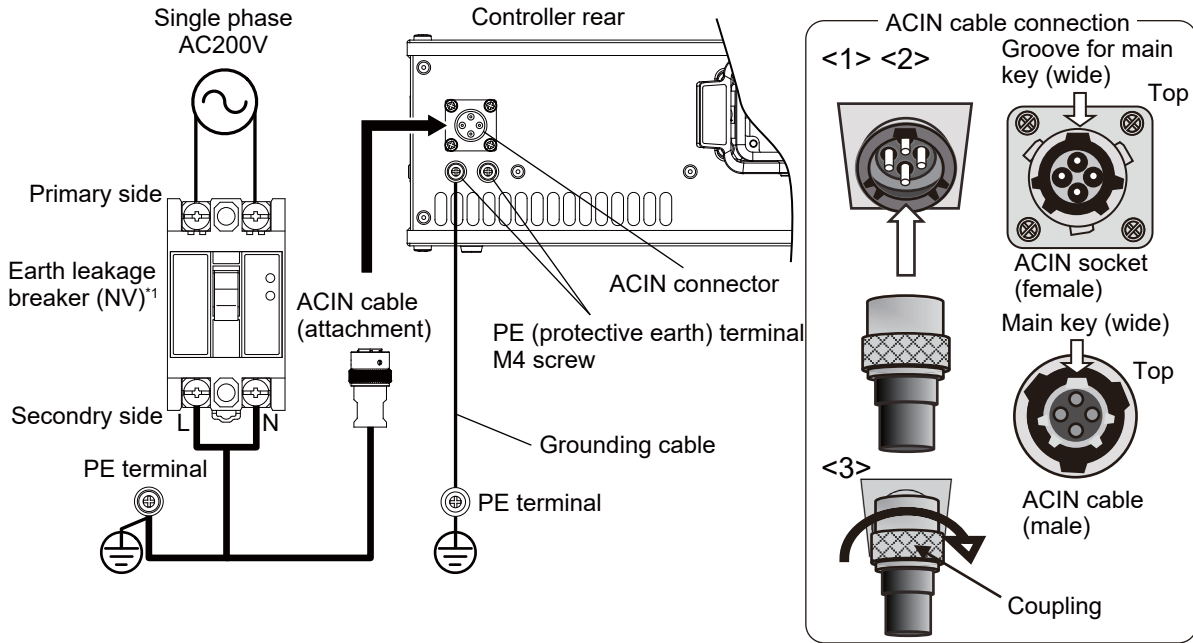

*1 Always use the terminal cover for the earth leakage breaker.

1. Prepare the following items.

Part name	Specifications	Remarks
Earth leakage breaker	The following is recommended product. Single phase: NV30FAU-2P-10A-AC100-240V-30mA (Terminal cover: TCS-05FA2)	Prepared by customer.
Cable for primary power supply	AWG #14(2mm ²) or above	Prepared by customer. Tightening torque for terminal fixing screw is 2 to 3N·m.
Grounding cable	AWG #14(2mm ²) or above	Prepared by customer. Tightening torque for terminal fixing screw is 2 to 3N·m.
ACIN cable	Terminal: M5, cable length: 3m	Supplied with the product.

2. Confirm that the primary power matches the specifications.

3. Confirm that the primary power is OFF and that the earth leakage breaker power switch is OFF.

4. Connect the ACIN cable to the breaker.

Connect the power terminals of the ACIN cable to the secondary side terminals of the earth leakage breaker. Also, ground the FG terminal of the cable.

5. Connect the ACIN cable to the ACIN connector on the rear of the controller.

<1> Face the main key on the ACIN cable plug upwards. (Refer to the "ACIN cable connection" illustration.)

<2> Align the main key of the ACIN cable plug with the grooves on the ACIN connector.

Push the plug into the connector as far as it will go. The plug may be damaged if it is not correctly aligned with the connector.

<3> Tighten the coupling on the ACIN cable, turning it to the right until it locks.

6. Connect one end of the grounding cable to the PE (protective earth) terminal on the controller and ground the other end (2-point grounding) in order to comply with the requirements of EN 61800-5-1 for the touch current of 3.5 mAAC or more.

7. Connect the primary power cable to the primary side terminal of the earth leakage breaker.

CAUTION

Be careful of interference with peripheral equipment.

Especially don't give a shock to the shaft (J3 axis). When you install the hand, be careful not to knock at the shaft end by the hammer etc. The shaft may be damaged.

Collision detection function is valid condition for both of automatic and jog operation at shipping in RH-3FRHR series.

However, damage to the ball screw shaft cannot be prevented completely.

Refer to  CR800 Series Controller INSTRUCTION MANUAL Detailed explanations of functions and operations (BFP-A3478) for collision detection function.

Take care also of the following items.

(1) The robot's locus of movement may change with specified speed.

Especially as for the corner section, short cut distance may change.

Therefore, when beginning automatic operation, moves at low speed at first, and you should gather speed slowly with being careful of interference with peripheral equipment.

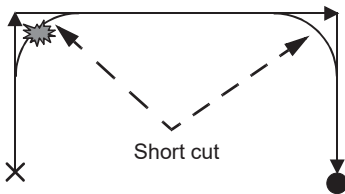

Arch movement (example)

(2) It can be confirmed whether the specified position exist in the defined area by using the instruction command "Zone".

It can utilize as one of the methods for collision evasion. Refer to  CR800 Series Controller INSTRUCTION MANUAL Detailed explanations of functions and operations (BFP-A3478) of the separate volume for the details of the instruction command.

Introduction

This series offers small-size industrial robots developed using Mitsubishi's latest technology. They are especially designed to handle and assemble mechanical parts. They are Mitsubishi's answer to the customer's need to achieve a compact manufacturing facility capable of highly flexible production, as necessitated by the diffusion of high-density product groups and the shorter product life cycles that have become common-place in recent years.



About RH-3FRHR series, because the installation surface does not give limitation to the operating range, it can work to the layout in the customer flexibly.

However, to comply with the target application, a work system having a well-balanced robot arm, peripheral devices or robot and hand section must be structured.

When creating these specifications manual, we have edited them so that the Mitsubishi robot's characteristics and specifications can be easily understood by users considering the implementation of robots.

However, if there are any unclear points, please contact your nearest Mitsubishi branch or dealer.

Mitsubishi hopes that you will consider these specifications manual and use our robots.

Note that in this specification document the specifications related to the robot arm is described  Page 48 Robot arm, the specifications related to the controller  Page 188 Controller, and software functions and a command list  Page 269 Software separately.

The CR800 controller indicates the CR800-D, CR800-Q, or CR800-R controller.

This document has indicated the specification of the following types robot.

<Robot type>

●On floor type

*RH-3FRH series

*RH-6FRH series

*RH-12FRH series

*RH-20FRH series

●Ceiling mounted type

*RH-3FRHR series

CONTENTS

SAFETY PRECAUTIONS	1
CR800 controller	6
Introduction	8
CHAPTER 1 General configuration	12
1.1 Structural equipment	12
Standard structural equipment	12
Special specifications	12
Options	12
Maintenance parts	12
1.2 Model type name of robot	13
How to identify the robot model	13
Combination of the robot arm and the controller	15
Inclusion of machine cable	26
1.3 Indirect export	27
1.4 Instruction manuals	27
1.5 Contents of the structural equipment	28
Robot arm	28
Controller	36
Function extension device	42
1.6 Contents of the Option equipment and special specification	43
List of the robot arm option equipment and special specification	43
List of the controller option equipment and special specification	45
Function extension device	47
CHAPTER 2 Robot arm	48
2.1 Standard specifications	48
Basic specifications	48
The counter-force applied to the installation surface	60
RH-3FRHR installation stage	61
2.2 Definition of specifications	63
Pose repeatability	63
Mass capacity	64
Relationships Among Mass Capacity, Speed, and Acceleration/Deceleration Speed	67
Vibrations at the Tip of the Arm during Low-Speed Operation of the Robot	68
Vibration of shaft (J3 axis) position and arm end	69
About moving speed at singular point and near singular point. (RH-3FRHR series)	75
Collision detection	76
Protection specifications	77
Clean specifications	80
2.3 Names of each part of the robot	82
2.4 Outside dimensions • Operating range diagram	84
Outside dimensions • Operating range diagram (RH-3FRH series)	84
Outside dimensions • Operating range diagram (RH-6FRH series)	96
Outside dimensions • Operating range diagram (RH-12FRH series)	108
Outside dimensions • Operating range diagram (RH-20FRH series)	120
Outside dimensions • Operating range diagram of RH-3FRHR series	128
Mechanical interface and Installation surface	132

	Outside dimensions of machine cables	138
2.5	Tooling	139
	Wiring and piping for hand	139
	Internal air piping	142
	Internal wiring for the hand output cable	143
	Internal wiring for the hand input cable	143
	Ethernet cable (For RH-3FRH/6FRH/12FRH/20FRH series)	144
	Spare Wiring (For FH-3FRHR series)	145
	About the Installation of Tooling Wiring and Piping (Examples of Wiring and Piping)	146
	Wiring and piping system diagram for hand	154
	Electrical specifications of hand input/output	157
	Air supply circuit example for the hand	158
2.6	Options	159
	Machine cable (replacement)	159
	Stopper for changing the operating range	162
	Solenoid valve set	164
	Hand input cable	171
	Hand output cable	174
	Hand curl tube	176
	Hand tube	178
	Internal Wiring/Piping set for hand	179
	External Wiring/Piping box	182
2.7	About Overhaul	186
2.8	Maintenance parts	187

CHAPTER 3 Controller 188

3.1	Standard specifications	188
	Basic specifications	188
	Protection specifications and operating supply	198
3.2	Names of each part	199
	Controller	199
	Robot CPU unit	201
3.3	Outside dimensions/Installation dimensions	205
	Outside dimensions	205
	Installation dimensions	208
3.4	External input/output	211
	Types	211
3.5	Dedicated input/output	212
3.6	Emergency stop input and output etc.	214
	Connection of the external emergency stop and mode selector switch	215
	Special stop input (SKIP)	219
	Door switch function	220
	Mode selector switch function	221
3.7	Additional Axis Function	222
	Wiring of the Additional Axis Interface	222
	Example of the installation of the noise filter	223
3.8	Additional axis synchronization output	226
3.9	Options	228
	CR800-D/R/Q controller common	228
	CR800-D controller	244

3.10	Maintenance parts	268
CHAPTER 4 Software		269
4.1	List of commands	269
4.2	List of parameters	272
CHAPTER 5 Instruction Manual		274
5.1	Details of each instruction manual	274
CHAPTER 6 Safety		275
6.1	Safety	275
	Self-diagnosis stop functions	275
	External input/output signals that can be used for safety protection measures	276
	Precautions for using robot	276
	Safety measures for automatic operation	277
	Safety measures for teaching	277
	Safety measures for maintenance and inspections, etc.	277
	Examples of safety measures	278
6.2	Working environment	283
	Power supply	283
	Noise	283
	Temperature and humidity	283
	Vibration	283
	Installation environment	283
6.3	Precautions for handling	284
6.4	EMC installation guideline	286
	Outlines	286
	EMC	286
	EMC measures	286
	Example of EMC measures	287
	Parts for EMC measures	287
6.5	Standards	287
Appendix		288
Appendix 1 Inertia calculation method		288
Appendix 2 Classification of functions using external input/output signals		289
Appendix 3 Safety diagnosis function (Test pulse diagnosis)		290
Appendix 4 Safety block diagram		291
Appendix 5 Origin position adjustment of J2 axis		292
Appendix 6 Specifications discussion material (RH-3FRH series)		293
Appendix 7 Specifications discussion material (RH-6FRH series)		294
Appendix 8 Specifications discussion material (RH-12FRH series)		295
Appendix 9 Specifications discussion material (RH-20FRH series)		296
Appendix 10 Specifications discussion material (RH-3FRHR series)		297
REVISIONS		298
TRADEMARKS		300

1 General configuration

1.1 Structural equipment

Structural equipment consists of the following types.

Standard structural equipment

The following items are enclosed as a standard.

No.	Item	Stand alone type	MELSEC iQ-R compatible type	MELSEC-Q compatible type
1	Robot arm	○	○	○
2	Controller	○	○	○
3	Robot CPU unit (MELSEC iQ-R compatible) *1	—	○	—
	Robot CPU unit (MELSEC-Q compatible) *1	—	—	○
4	Machine cable	○	○	○
5	Robot arm installation bolts	○	○	○
6	CD-ROM (Instruction manual)	○	○	○

*1 Including robot CPU unit connecting cable

Special specifications

For the special specifications, some standard configuration equipment and specifications have to be changed before factory shipping. Confirm the delivery date and specify the special specifications at the order.

Options

User can install options after their delivery. The customer needs to arrange for the installation.

Maintenance parts

Materials and parts for the maintenance use.

1.2 Model type name of robot







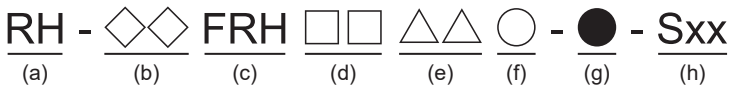

This robot has arranged the type name corresponding to load mass, arm length, and environment specification. Details are shown below, please select the robot suitable for the customer's use.

How to identify the robot model

There are two types of robot, one is "Floor installation type" and the other is "Ceiling mounted type", each of which are different in installation posture.

Floor installation type



No.	Symbol	Description
(a)	RH	Indicates horizontal articulated robots.
(b)	 	Indicates the maximum load. Ex.) 3:3kg 6:6kg 12:12kg 20:20kg
(c)	FRH	Indicates the FRH series.
(d)	 	Indicates the arm length. Ex.) 35:350mm 45:450mm 55:550mm 70:700mm 85:850mm 100:1000mm
(e)	 	Indicates the vertical stroke length. Ex.) 12:120mm stroke 15:150mm stroke 20:200mm stroke 34:340mm stroke 35:350mm stroke 45:450mm stroke
(f)		Indicates environment specification. Ex.) Omitted: General specifications C : Clean specifications M : Oil mist specifications
(g)		Indicates the controller series. Ex.) D : Stand alone type R : MELSEC iQ-R compatible type Q : MELSEC-Q compatible type
(h)	-Sxx	Indicates a special model. In order, limit special specification. Ex.) -SN : Indicates the machine cable is not included. -Sxx : Indicates a special model.

Ceiling mounted type

$\text{RH} - \text{3} \text{FRH} \text{R} \text{35} \triangle\triangle \bigcirc - \bullet - \text{Sxx}$
 (a) (b) (c) (d) (e) (f) (g) (h) (i)

No.	Symbol	Description
(a)	RH	Indicates horizontal articulated robots.
(b)	3	Indicates the maximum load. 3 : 3kg
(c)	FRH	Indicates the FRH series.
(d)	R	Indicates the installation posture is hung.
(e)	35	Indicates the arm length. 35 : 350mm
(f)	$\triangle\triangle$	Indicates the vertical stroke length. Ex.) 12 : 120mm stroke 15 : 150mm stroke
(g)	\bigcirc	Indicates environment specification. Ex.) Omitted: General specifications C : Clean specifications W : Waterproof specifications
(h)	\bullet	Indicates the controller series. Ex.) D : Stand alone type R : MELSEC iQ-R compatible type Q : MELSEC-Q compatible type
(i)	-Sxx	Indicates a special model. In order, limit special specification. Ex.) -SN : Indicates the machine cable is not included. -Sxx : Indicates a special model.

Combination of the robot arm and the controller

Stand alone type

Table: Combination of the robot arm (floor installation type) and controller

Protection specification	Robot arm (Floor installation type)	Arm length (mm)	Machine cable (5m)	J3-axis stroke (mm)	Controller *1
RH-3FRH series					
General-purpose environment	RH-3FRH3515-D	350	Included	150	CR800-03HD
	RH-3FRH4515-D	450			
	RH-3FRH5515-D	550			
	RH-3FRH3515-D-SN	350	Not included *2		
	RH-3FRH4515-D-SN	450			
	RH-3FRH5515-D-SN	550			
Clean specifications	RH-3FRH3512C-D	350	Included	120	
	RH-3FRH4512C-D	450			
	RH-3FRH5512C-D	550			
	RH-3FRH3512C-D-SN	350	Not included *2		
	RH-3FRH4512C-D-SN	450			
	RH-3FRH5512C-D-SN	550			

Protection specification	Robot arm (Floor installation type)	Arm length (mm)	Machine cable (5m)	J3-axis stroke (mm)	Controller *1
RH-6FRH series					
General-purpose environment	RH-6FRH3520-D	350	Included	200	CR800-06HD
	RH-6FRH4520-D	450			
	RH-6FRH5520-D	550			
	RH-6FRH3534-D	350		340	
	RH-6FRH4534-D	450			
	RH-6FRH5534-D	550			
	RH-6FRH3520-D-SN	350	Not included *2	200	
	RH-6FRH4520-D-SN	450			
	RH-6FRH5520-D-SN	550			
	RH-6FRH3534-D-SN	350		340	
	RH-6FRH4534-D-SN	450			
	RH-6FRH5534-D-SN	550			
Clean specifications	RH-6FRH3520C-D	350	Included	200	
	RH-6FRH4520C-D	450			
	RH-6FRH5520C-D	550			
	RH-6FRH3534C-D	350		340	
	RH-6FRH4534C-D	450			
	RH-6FRH5534C-D	550			
	RH-6FRH3520C-D-SN	350	Not included *2	200	
	RH-6FRH4520C-D-SN	450			
	RH-6FRH5520C-D-SN	550			
	RH-6FRH3534C-D-SN	350		340	
	RH-6FRH4534C-D-SN	450			
	RH-6FRH5534C-D-SN	550			
Oil mist specifications	RH-6FRH3520M-D	350	Included	200	
	RH-6FRH4520M-D	450			
	RH-6FRH5520M-D	550			
	RH-6FRH3534M-D	350		340	
	RH-6FRH4534M-D	450			
	RH-6FRH5534M-D	550			
	RH-6FRH3520M-D-SN	350	Not included *2	200	
	RH-6FRH4520M-D-SN	450			
	RH-6FRH5520M-D-SN	550			
	RH-6FRH3534M-D-SN	350		340	
	RH-6FRH4534M-D-SN	450			
	RH-6FRH5534M-D-SN	550			

Protection specification	Robot arm (Floor installation type)	Arm length (mm)	Machine cable (5m)	J3-axis stroke (mm)	Controller *1
RH-12FRH series					
General-purpose environment	RH-12FRH5535-D	550	Included	350	CR800-12HD
	RH-12FRH7035-D	700			
	RH-12FRH8535-D	850			
	RH-12FRH5545-D	550		450	
	RH-12FRH7045-D	700			
	RH-12FRH8545-D	850			
	RH-12FRH5535-D-SN	550	Not included *2	350	
	RH-12FRH7035-D-SN	700			
	RH-12FRH8535-D-SN	850			
	RH-12FRH5545-D-SN	550		450	
	RH-12FRH7045-D-SN	700			
	RH-12FRH8545-D-SN	850			
Clean specifications	RH-12FRH5535C-D	550	Included	350	CR800-12HD
	RH-12FRH7035C-D	700			
	RH-12FRH8535C-D	850			
	RH-12FRH5545C-D	550		450	
	RH-12FRH7045C-D	700			
	RH-12FRH8545C-D	850			
	RH-12FRH5535C-D-SN	550	Not included *2	350	
	RH-12FRH7035C-D-SN	700			
	RH-12FRH8535C-D-SN	850			
	RH-12FRH5545C-D-SN	550		450	
	RH-12FRH7045C-D-SN	700			
	RH-12FRH8545C-D-SN	850			
Oil mist specifications	RH-12FRH5535M-D	550	Included	350	CR800-12HD
	RH-12FRH7035M-D	700			
	RH-12FRH8535M-D	850			
	RH-12FRH5545M-D	550		450	
	RH-12FRH7045M-D	700			
	RH-12FRH8545M-D	850			
	RH-12FRH5535M-D-SN	550	Not included *2	350	
	RH-12FRH7035M-D-SN	700			
	RH-12FRH8535M-D-SN	850			
	RH-12FRH5545M-D-SN	550		450	
	RH-12FRH7045M-D-SN	700			
	RH-12FRH8545M-D-SN	850			

Protection specification	Robot arm (Floor installation type)	Arm length (mm)	Machine cable (5m)	J3-axis stroke (mm)	Controller *1	
RH-20FRH series						
General-purpose environment	RH-20FRH8535-D	850	Included	350	CR800-20HD	
	RH-20FRH10035-D	1000		Not included *2		450
	RH-20FRH8545-D	850				350
	RH-20FRH10045-D	1000				450
	RH-20FRH8535-D-SN	850	Not included *2			350
	RH-20FRH10035-D-SN	1000		450		
	RH-20FRH8545-D-SN	850		350		
	RH-20FRH10045-D-SN	1000		450		
Clean specifications	RH-20FRH8535C-D	850	Included	350	CR800-20HD	
	RH-20FRH10035C-D	1000		Not included *2		450
	RH-20FRH8545C-D	850				350
	RH-20FRH10045C-D	1000				450
	RH-20FRH8535C-D-SN	850	Not included *2			350
	RH-20FRH10035C-D-SN	1000		450		
	RH-20FRH8545C-D-SN	850		350		
	RH-20FRH10045C-D-SN	1000		450		
Oil mist specifications	RH-20FRH8535M-D	850	Included	350	CR800-20HD	
	RH-20FRH10035M-D	1000		Not included *2		450
	RH-20FRH8545M-D	850				350
	RH-20FRH10045M-D	1000				450
	RH-20FRH8535M-D-SN	850	Not included *2			350
	RH-20FRH10035M-D-SN	1000		450		
	RH-20FRH8545M-D-SN	850		350		
	RH-20FRH10045M-D-SN	1000		450		

*1 When you use by adverse environment, please use the controller protection box.

*2 This robot arm is a shipping special specification model. Check the delivery date.

Table: Combination of the robot arm (Ceiling mounted type) and the controller

Protection specification	Robot arm (Ceiling mounted type)	Arm length (mm)	Machine cable (5m)	J3-axis stroke (mm)	Controller *1
RH-3FRHR series					
General-purpose environment	RH-3FRHR3515-D	350	Included	150	CR800-03HRD
	RH-3FRHR3515-D-SN		Not included *2		
Clean specifications	RH-3FRHR3512C-D	350	Included	120	
	RH-3FRHR3512C-D-SN		Not included *2		
Waterproof specifications	RH-3FRHR3512W-D	350	Included	120	
	RH-3FRHR3512W-D-SN		Not included *2		

*1 When you use by adverse environment, please use the controller protection box.

*2 This robot arm is a shipping special specification model. Check the delivery date.

MELSEC iQ-R compatible type

Table: Combination of the robot arm (floor installation type) and controller

Protection specification	Robot arm (Floor installation type)	Arm length (mm)	Machine cable (5m)	J3-axis stroke (mm)	Controller *1
RH-3FRH series					
General-purpose environment	RH-3FRH3515-R	350	Included	150	CR800-03HR
	RH-3FRH4515-R	450			
	RH-3FRH5515-R	550			
	RH-3FRH3515-R-SN	350	Not included *2		
	RH-3FRH4515-R-SN	450			
	RH-3FRH5515-R-SN	550			
Clean specifications	RH-3FRH3512C-R	350	Included	120	CR800-03HR
	RH-3FRH4512C-R	450			
	RH-3FRH5512C-R	550			
	RH-3FRH3512C-R-SN	350	Not included *2		
	RH-3FRH4512C-R-SN	450			
	RH-3FRH5512C-R-SN	550			

Protection specification	Robot arm (Floor installation type)	Arm length (mm)	Machine cable (5m)	J3-axis stroke (mm)	Controller *1
RH-6FRH series					
General-purpose environment	RH-6FRH3520-R	350	Included	200	CR800-06HR
	RH-6FRH4520-R	450			
	RH-6FRH5520-R	550			
	RH-6FRH3534-R	350		340	
	RH-6FRH4534-R	450			
	RH-6FRH5534-R	550			
	RH-6FRH3520-R-SN	350	Not included *2	200	
	RH-6FRH4520-R-SN	450			
	RH-6FRH5520-R-SN	550			
	RH-6FRH3534-R-SN	350		340	
	RH-6FRH4534-R-SN	450			
	RH-6FRH5534-R-SN	550			
Clean specifications	RH-6FRH3520C-R	350	Included	200	
	RH-6FRH4520C-R	450			
	RH-6FRH5520C-R	550			
	RH-6FRH3534C-R	350		340	
	RH-6FRH4534C-R	450			
	RH-6FRH5534C-R	550			
	RH-6FRH3520C-R-SN	350	Not included *2	200	
	RH-6FRH4520C-R-SN	450			
	RH-6FRH5520C-R-SN	550			
	RH-6FRH3534C-R-SN	350		340	
	RH-6FRH4534C-R-SN	450			
	RH-6FRH5534C-R-SN	550			
Oil mist specifications	RH-6FRH3520M-R	350	Included	200	
	RH-6FRH4520M-R	450			
	RH-6FRH5520M-R	550			
	RH-6FRH3534M-R	350		340	
	RH-6FRH4534M-R	450			
	RH-6FRH5534M-R	550			
	RH-6FRH3520M-R-SN	350	Not included *2	200	
	RH-6FRH4520M-R-SN	450			
	RH-6FRH5520M-R-SN	550			
	RH-6FRH3534M-R-SN	350		340	
	RH-6FRH4534M-R-SN	450			
	RH-6FRH5534M-R-SN	550			

Protection specification	Robot arm (Floor installation type)	Arm length (mm)	Machine cable (5m)	J3-axis stroke (mm)	Controller *1
RH-12FRH series					
General-purpose environment	RH-12FRH5535-R	550	Included	350	CR800-12HR
	RH-12FRH7035-R	700			
	RH-12FRH8535-R	850			
	RH-12FRH5545-R	550		450	
	RH-12FRH7045-R	700			
	RH-12FRH8545-R	850			
	RH-12FRH5535-R-SN	550	Not included *2	350	
	RH-12FRH7035-R-SN	700			
	RH-12FRH8535-R-SN	850			
	RH-12FRH5545-R-SN	550		450	
	RH-12FRH7045-R-SN	700			
	RH-12FRH8545-R-SN	850			
Clean specifications	RH-12FRH5535C-R	550	Included	350	CR800-12HR
	RH-12FRH7035C-R	700			
	RH-12FRH8535C-R	850			
	RH-12FRH5545C-R	550		450	
	RH-12FRH7045C-R	700			
	RH-12FRH8545C-R	850			
	RH-12FRH5535C-R-SN	550	Not included *2	350	
	RH-12FRH7035C-R-SN	700			
	RH-12FRH8535C-R-SN	850			
	RH-12FRH5545C-R-SN	550		450	
	RH-12FRH7045C-R-SN	700			
	RH-12FRH8545C-R-SN	850			
Oil mist specifications	RH-12FRH5535M-R	550	Included	350	CR800-12HR
	RH-12FRH7035M-R	700			
	RH-12FRH8535M-R	850			
	RH-12FRH5545M-R	550		450	
	RH-12FRH7045M-R	700			
	RH-12FRH8545M-R	850			
	RH-12FRH5535M-R-SN	550	Not included *2	350	
	RH-12FRH7035M-R-SN	700			
	RH-12FRH8535M-R-SN	850			
	RH-12FRH5545M-R-SN	550		450	
	RH-12FRH7045M-R-SN	700			
	RH-12FRH8545M-R-SN	850			

Protection specification	Robot arm (Floor installation type)	Arm length (mm)	Machine cable (5m)	J3-axis stroke (mm)	Controller *1	
RH-20FRH series						
General-purpose environment	RH-20FRH8535-R	850	Included	350	CR800-20HR	
	RH-20FRH10035-R	1000		Not included *2		450
	RH-20FRH8545-R	850				350
	RH-20FRH10045-R	1000				450
	RH-20FRH8535-R-SN	850	Not included *2			350
	RH-20FRH10035-R-SN	1000		450		
	RH-20FRH8545-R-SN	850				
	RH-20FRH10045-R-SN	1000				
Clean specifications	RH-20FRH8535C-R	850	Included		350	CR800-20HR
	RH-20FRH10035C-R	1000		Not included *2	450	
	RH-20FRH8545C-R	850			350	
	RH-20FRH10045C-R	1000			450	
	RH-20FRH8535C-R-SN	850	Not included *2		350	
	RH-20FRH10035C-R-SN	1000		450		
	RH-20FRH8545C-R-SN	850				
	RH-20FRH10045C-R-SN	1000				
Oil mist specifications	RH-20FRH8535M-R	850	Included		350	CR800-20HR
	RH-20FRH10035M-R	1000		Not included *2	450	
	RH-20FRH8545M-R	850			350	
	RH-20FRH10045M-R	1000			450	
	RH-20FRH8535M-R-SN	850	Not included *2		350	
	RH-20FRH10035M-R-SN	1000		450		
	RH-20FRH8545M-R-SN	850				
	RH-20FRH10045M-R-SN	1000				

*1 When you use by adverse environment, please use the controller protection box.

*2 This robot arm is a shipping special specification model. Check the delivery date.

Table: Combination of the robot arm (Ceiling mounted type) and the controller

Protection specification	Robot arm (Ceiling mounted type)	Arm length (mm)	Machine cable (5m)	J3-axis stroke (mm)	Controller *1
RH-3FRHR series					
General-purpose environment	RH-3FRHR3515-R	350	Included	150	CR800-03HRR
	RH-3FRHR3515-R-SN		Not included *2		
Clean specifications	RH-3FRHR3512C-R	350	Included	120	
	RH-3FRHR3512C-R-SN		Not included *2		
Waterproof specifications	RH-3FRHR3512W-R	350	Included	120	
	RH-3FRHR3512W-R-SN		Not included *2		

*1 When you use by adverse environment, please use the controller protection box.

*2 This robot arm is a shipping special specification model. Check the delivery date.

MELSEC-Q compatible type

Table: Combination of the robot arm (floor installation type) and controller

Protection specification	Robot arm (Floor installation type)	Arm length (mm)	Machine cable (5m)	J3-axis stroke (mm)	Controller *1
RH-3FRH series					
General-purpose environment	RH-3FRH3515-Q	350	Included	150	CR800-03HQ
	RH-3FRH4515-Q	450			
	RH-3FRH5515-Q	550			
	RH-3FRH3515-Q-SN	350	Not included *2		
	RH-3FRH4515-Q-SN	450			
	RH-3FRH5515-Q-SN	550			
Clean specifications	RH-3FRH3512C-Q	350	Included	120	CR800-03HQ
	RH-3FRH4512C-Q	450			
	RH-3FRH5512C-Q	550			
	RH-3FRH3512C-Q-SN	350	Not included *2		
	RH-3FRH4512C-Q-SN	450			
	RH-3FRH5512C-Q-SN	550			

Protection specification	Robot arm (Floor installation type)	Arm length (mm)	Machine cable (5m)	J3-axis stroke (mm)	Controller *1
RH-6FRH series					
General-purpose environment	RH-6FRH3520-Q	350	Included	200	CR800-06HQ
	RH-6FRH4520-Q	450			
	RH-6FRH5520-Q	550			
	RH-6FRH3534-Q	350		340	
	RH-6FRH4534-Q	450			
	RH-6FRH5534-Q	550			
	RH-6FRH3520-Q-SN	350	Not included *2	200	
	RH-6FRH4520-Q-SN	450			
	RH-6FRH5520-Q-SN	550			
	RH-6FRH3534-Q-SN	350		340	
	RH-6FRH4534-Q-SN	450			
	RH-6FRH5534-Q-SN	550			
Clean specifications	RH-6FRH3520C-Q	350	Included	200	
	RH-6FRH4520C-Q	450			
	RH-6FRH5520C-Q	550			
	RH-6FRH3534C-Q	350		340	
	RH-6FRH4534C-Q	450			
	RH-6FRH5534C-Q	550			
	RH-6FRH3520C-Q-SN	350	Not included *2	200	
	RH-6FRH4520C-Q-SN	450			
	RH-6FRH5520C-Q-SN	550			
	RH-6FRH3534C-Q-SN	350		340	
	RH-6FRH4534C-Q-SN	450			
	RH-6FRH5534C-Q-SN	550			
Oil mist specifications	RH-6FRH3520M-Q	350	Included	200	
	RH-6FRH4520M-Q	450			
	RH-6FRH5520M-Q	550			
	RH-6FRH3534M-Q	350		340	
	RH-6FRH4534M-Q	450			
	RH-6FRH5534M-Q	550			
	RH-6FRH3520M-Q-SN	350	Not included *2	200	
	RH-6FRH4520M-Q-SN	450			
	RH-6FRH5520M-Q-SN	550			
	RH-6FRH3534M-Q-SN	350		340	
	RH-6FRH4534M-Q-SN	450			
	RH-6FRH5534M-Q-SN	550			

Protection specification	Robot arm (Floor installation type)	Arm length (mm)	Machine cable (5m)	J3-axis stroke (mm)	Controller *1
RH-12FRH series					
General-purpose environment	RH-12FRH5535-Q	550	Included	350	CR800-12HQ
	RH-12FRH7035-Q	700			
	RH-12FRH8535-Q	850			
	RH-12FRH5545-Q	550		450	
	RH-12FRH7045-Q	700			
	RH-12FRH8545-Q	850			
	RH-12FRH5535-Q-SN	550	Not included *2	350	
	RH-12FRH7035-Q-SN	700			
	RH-12FRH8535-Q-SN	850			
	RH-12FRH5545-Q-SN	550		450	
	RH-12FRH7045-Q-SN	700			
	RH-12FRH8545-Q-SN	850			
Clean specifications	RH-12FRH5535C-Q	550	Included	350	CR800-12HQ
	RH-12FRH7035C-Q	700			
	RH-12FRH8535C-Q	850			
	RH-12FRH5545C-Q	550		450	
	RH-12FRH7045C-Q	700			
	RH-12FRH8545C-Q	850			
	RH-12FRH5535C-Q-SN	550	Not included *2	350	
	RH-12FRH7035C-Q-SN	700			
	RH-12FRH8535C-Q-SN	850			
	RH-12FRH5545C-Q-SN	550		450	
	RH-12FRH7045C-Q-SN	700			
	RH-12FRH8545C-Q-SN	850			
Oil mist specifications	RH-12FRH5535M-Q	550	Included	350	CR800-12HQ
	RH-12FRH7035M-Q	700			
	RH-12FRH8535M-Q	850			
	RH-12FRH5545M-Q	550		450	
	RH-12FRH7045M-Q	700			
	RH-12FRH8545M-Q	850			
	RH-12FRH5535M-Q-SN	550	Not included *2	350	
	RH-12FRH7035M-Q-SN	700			
	RH-12FRH8535M-Q-SN	850			
	RH-12FRH5545M-Q-SN	550		450	
	RH-12FRH7045M-Q-SN	700			
	RH-12FRH8545M-Q-SN	850			

Protection specification	Robot arm (Floor installation type)	Arm length (mm)	Machine cable (5m)	J3-axis stroke (mm)	Controller *1
RH-20FRH series					
General-purpose environment	RH-20FRH8535-Q	850	Included	350	CR800-20HQ
	RH-20FRH10035-Q	1000		450	
	RH-20FRH8545-Q	850			
	RH-20FRH10045-Q	1000			
	RH-20FRH8535-Q-SN	850	Not included *2	350	
	RH-20FRH10035-Q-SN	1000		450	
	RH-20FRH8545-Q-SN	850			
	RH-20FRH10045-Q-SN	1000			
Clean specifications	RH-20FRH8535C-Q	850	Included	350	CR800-20HQ
	RH-20FRH10035C-Q	1000		450	
	RH-20FRH8545C-Q	850			
	RH-20FRH10045C-Q	1000			
	RH-20FRH8535C-Q-SN	850	Not included *2	350	
	RH-20FRH10035C-Q-SN	1000		450	
	RH-20FRH8545C-Q-SN	850			
	RH-20FRH10045C-Q-SN	1000			
Oil mist specifications	RH-20FRH8535M-Q	850	Included	350	CR800-20HQ
	RH-20FRH10035M-Q	1000		450	
	RH-20FRH8545M-Q	850			
	RH-20FRH10045M-Q	1000			
	RH-20FRH8535M-Q-SN	850	Not included *2	350	
	RH-20FRH10035M-Q-SN	1000		450	
	RH-20FRH8545M-Q-SN	850			
	RH-20FRH10045M-Q-SN	1000			

*1 When you use by adverse environment, please use the controller protection box.

*2 This robot arm is a shipping special specification model. Check the delivery date.

Table: Combination of the robot arm (Ceiling mounted type) and the controller

Protection specification	Robot arm (Ceiling mounted type)	Arm length (mm)	Machine cable (5m)	J3-axis stroke (mm)	Controller *1
RH-3FRHR series					
General-purpose environment	RH-3FRHR3515-Q	350	Included	150	CR800-03HRQ
	RH-3FRHR3515-Q-SN		Not included *2		
Clean specifications	RH-3FRHR3512C-Q	350	Included	120	
	RH-3FRHR3512C-Q-SN		Not included *2		
Waterproof specifications	RH-3FRHR3512W-Q	350	Included	120	
	RH-3FRHR3512W-Q-SN		Not included *2		

*1 When you use by adverse environment, please use the controller protection box.

*2 This robot arm is a shipping special specification model. Check the delivery date.

Inclusion of machine cable

It is possible to choose a product with or without a machine cable. Robots that do not come with a machine cable are indicated by the special characters -SN at the end of their model names. There is no difference in the robot's standard specifications regardless of whether a machine cable is included.

1.3 Indirect export

The display in English is available by setting parameter LNG as "ENG."

1.4 Instruction manuals

The instruction manuals supplied in CD-ROM.

1.5 Contents of the structural equipment

Robot arm

The list of structural equipment is shown in below.

Floor installation type

■RH-3FRH series

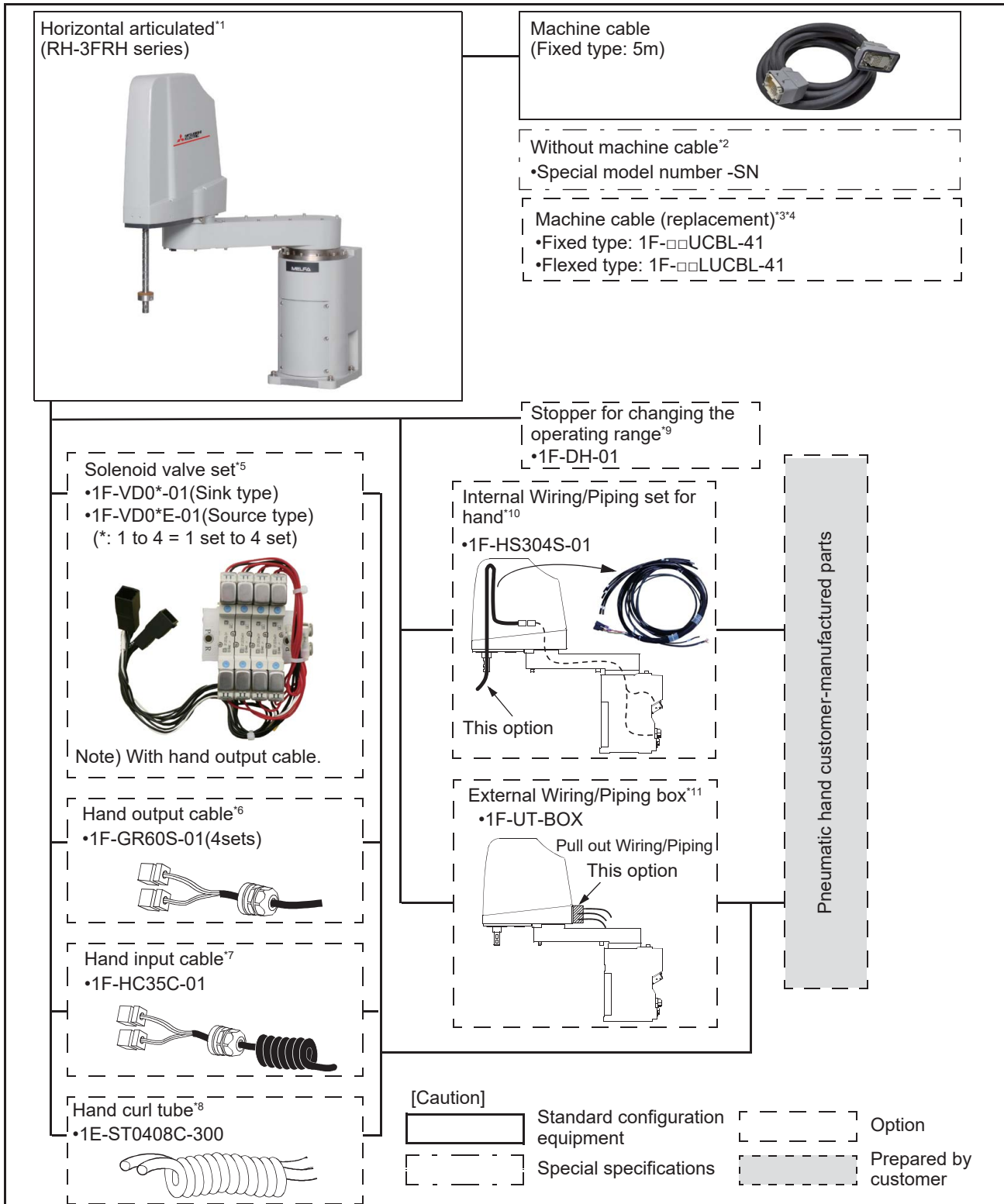











Fig.: Structural equipment (RH-3FRH series)

- *1 Refer to  Page 48 Standard specifications for details on the specifications
- *2 The machine cable (fixed type: 5m) is not included in the standard configuration.
Choose a suitable cable from the optional cables (replacements).
- *3 refer the length.
Refer to  Table: The list of the robot arm option equipment and special specification for details.
- *4 Replace the enclosed standard cable with this cable
- *5 Refer to the following page:
 Page 164 Solenoid valve set
- *6 Refer to the following page:
 Page 174 Hand output cable
- *7 Refer to the following page:
 Page 171 Hand input cable
- *8 Refer to the following page:
 Page 176 Hand curl tube
- *9 Refer to the following page:
 Page 162 Stopper for changing the operating range
- *10 Refer to the following page:
 Page 179 Internal Wiring/Piping set for hand
- *11 Refer to the following page:
 Page 182 External Wiring/Piping box

■RH-6FRH series

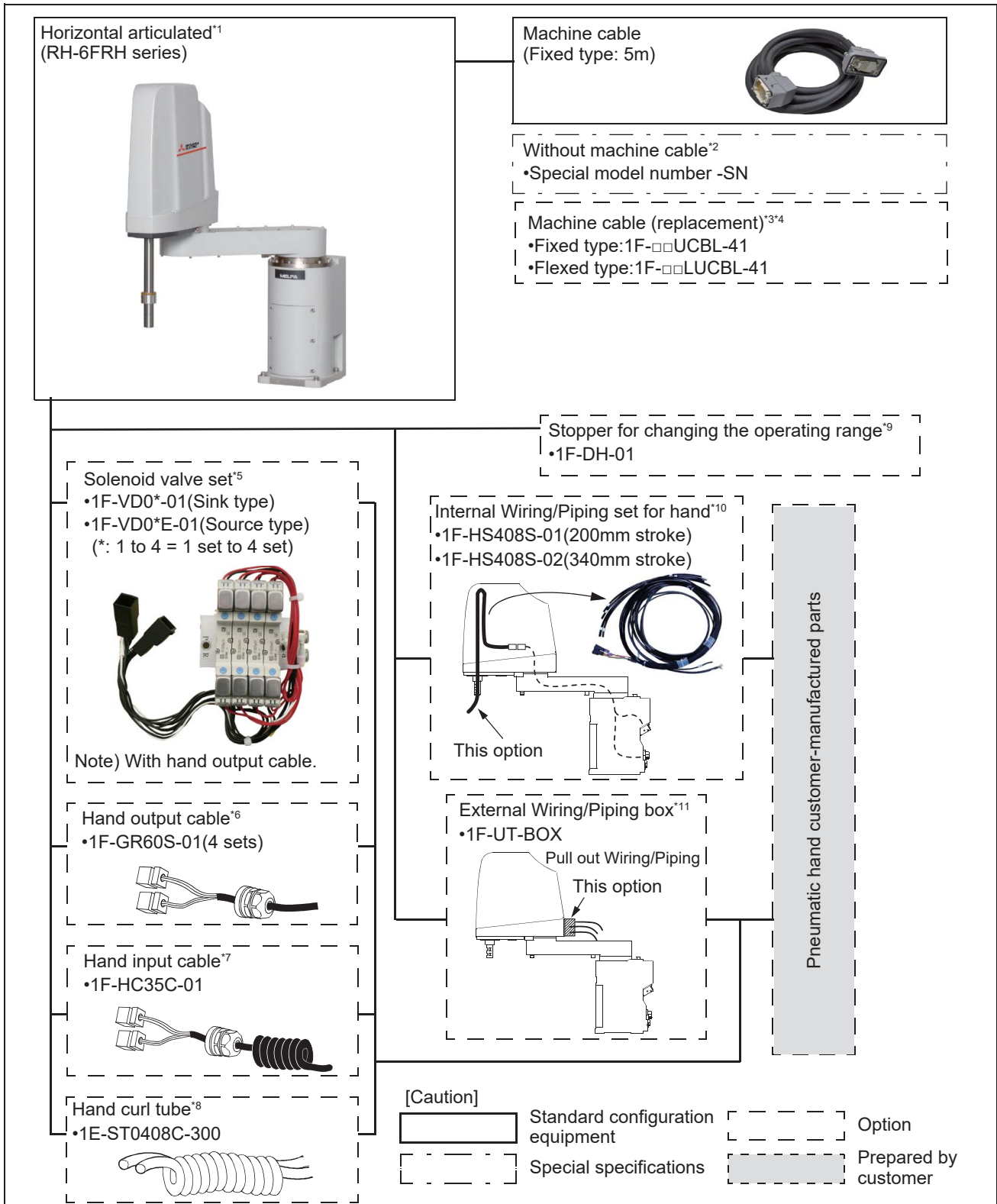

Fig.: Structural equipment (RH-6FRH series)

*1 Refer to Page 48 Standard specifications for details on the specifications

*2 The machine cable (fixed type: 5m) is not included in the standard configuration.
Choose a suitable cable from the optional cables (replacements).

*3 □□ refer the length.

Refer to Table: The list of the robot arm option equipment and special specification for details.

*4 Replace the enclosed standard cable with this cable

*5 Refer to the following page:

Page 164 Solenoid valve set

*6 Refer to the following page:

- ☞ Page 174 Hand output cable
- *7 Refer to the following page:
 - ☞ Page 171 Hand input cable
- *8 Refer to the following page:
 - ☞ Page 176 Hand curl tube
- *9 Refer to the following page:
 - ☞ Page 162 Stopper for changing the operating range
- *10 Refer to the following page:
 - ☞ Page 179 Internal Wiring/Piping set for hand
- *11 Refer to the following page:
 - ☞ Page 182 External Wiring/Piping box

■RH-12FRH/20FRH series

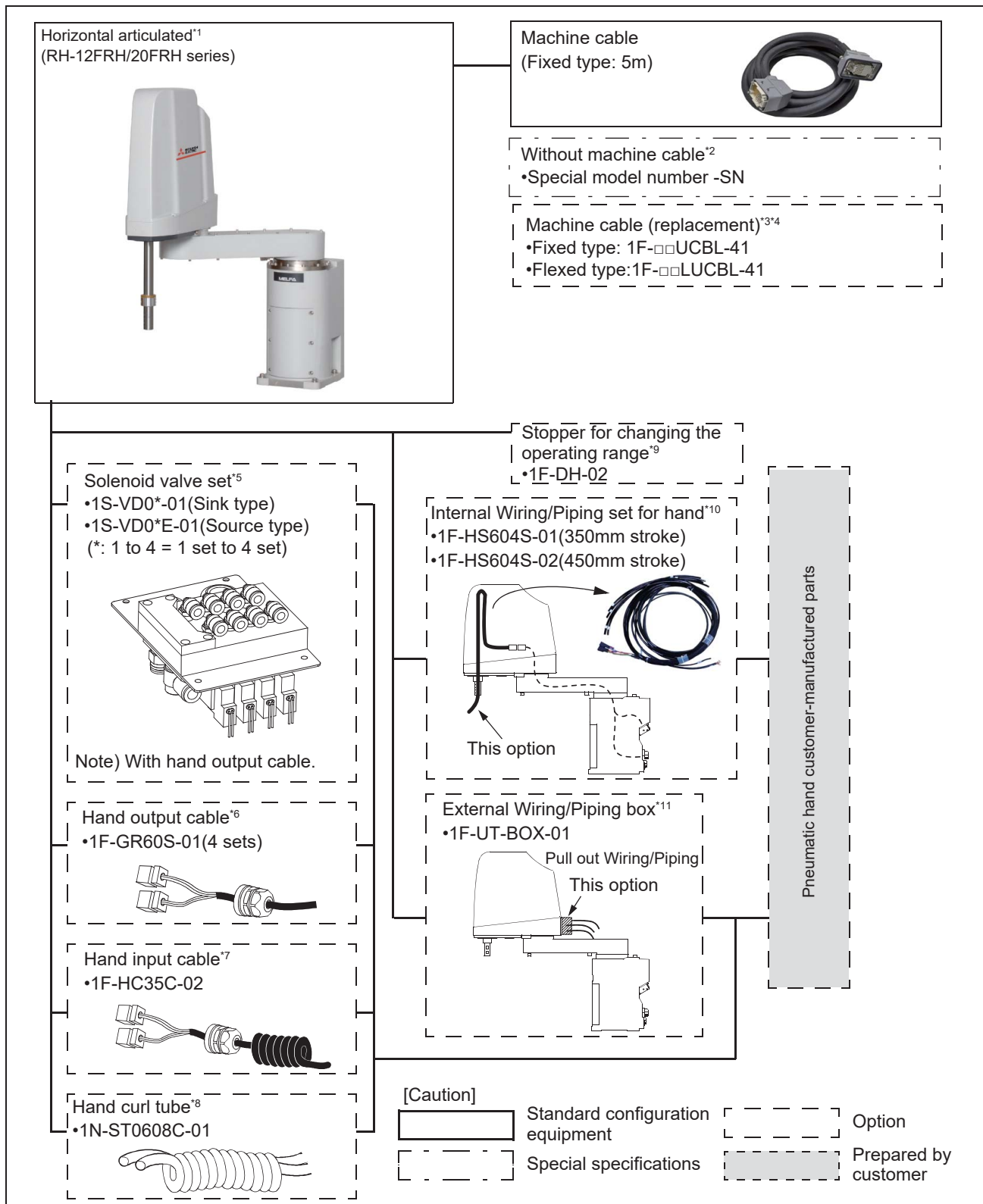

Fig.: Structural equipment (RH-12FRH/20FRH series)

*1 Refer to Page 48 Standard specifications for details on the specifications

*2 The machine cable (fixed type: 5m) is not included in the standard configuration.
Choose a suitable cable from the optional cables (replacements).

*3 □□ refer the length.

Refer to Table: The list of the robot arm option equipment and special specification for details.

*4 Replace the enclosed standard cable with this cable

*5 Refer to the following page:

Page 164 Solenoid valve set

*6 Refer to the following page:

- ☞ Page 174 Hand output cable
- *7 Refer to the following page:
 - ☞ Page 171 Hand input cable
- *8 Refer to the following page:
 - ☞ Page 176 Hand curl tube
- *9 Refer to the following page:
 - ☞ Page 162 Stopper for changing the operating range
- *10 Refer to the following page:
 - ☞ Page 179 Internal Wiring/Piping set for hand
- *11 Refer to the following page:
 - ☞ Page 182 External Wiring/Piping box

Ceiling mounted type

■RH-3FRHR series

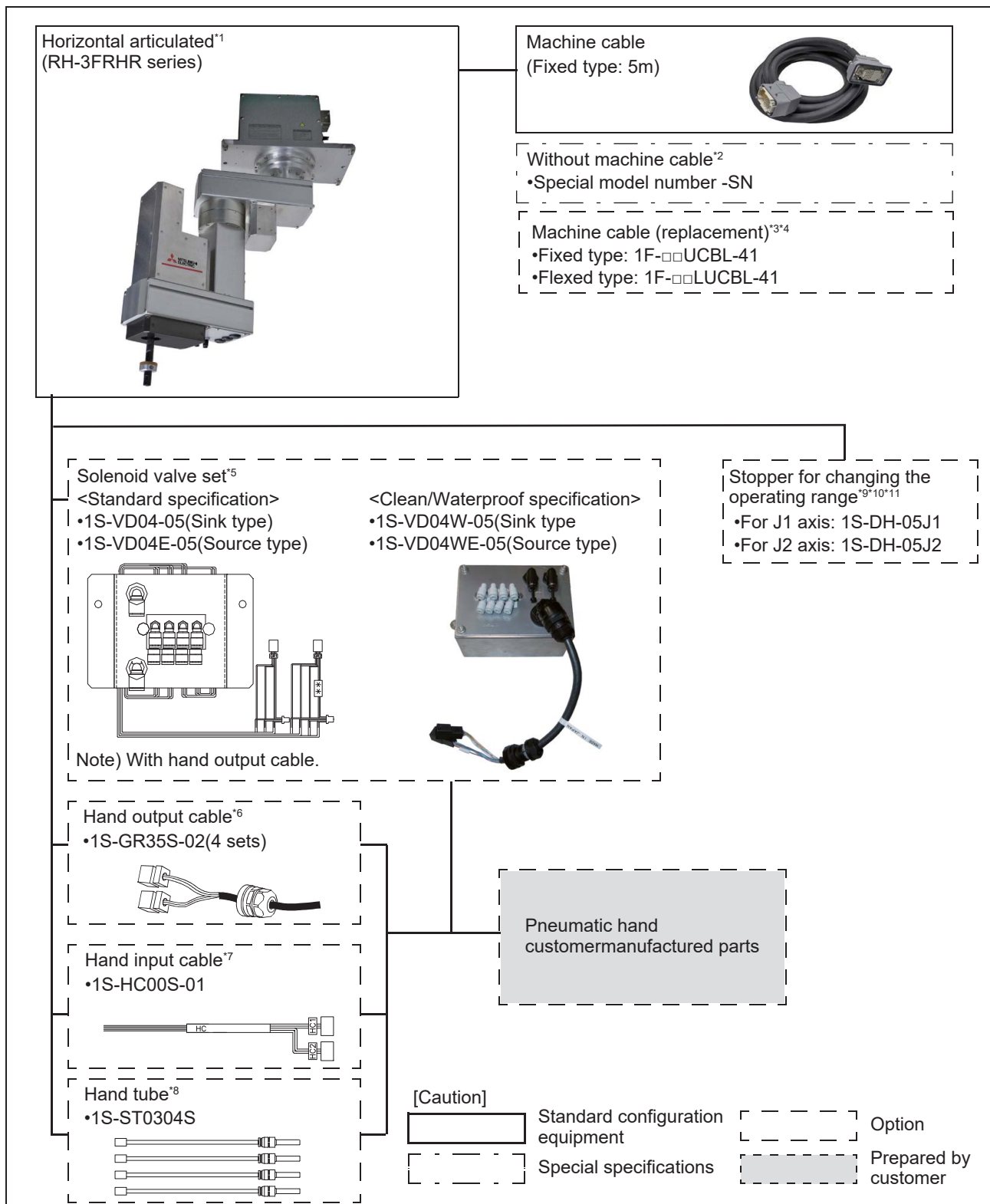

Fig.: Structural equipment (RH-3FRHR series)

*1 Refer to Page 48 Standard specifications for details on the specifications

*2 The machine cable (fixed type: 5m) is not included in the standard configuration.
Choose a suitable cable from the optional cables (replacements).

*3 □□ refer the length.

Refer to Table: The list of the robot arm option equipment and special specification for details.

*4 Replace the enclosed standard cable with this cable

*5 Refer to the following page:

- ☞ Page 164 Solenoid valve set
- *6 Refer to the following page:
 - ☞ Page 174 Hand output cable
- *7 Refer to the following page:
 - ☞ Page 171 Hand input cable
- *8 Refer to the following page:
 - ☞ Page 178 Hand tube
- *9 Refer to the following page:
 - ☞ Page 162 Stopper for changing the operating range
- *10 Refer to ☞ Table: The list of the robot arm option equipment and special specification for the angle which can be changed.
- *11 Installed by customer.

Controller

The devices shown below can be installed on the controller.

The controllers that can be connected differ depending on the specification of the robot. (Refer to  Page 13 Model type name of robot.)

CR800-D controller

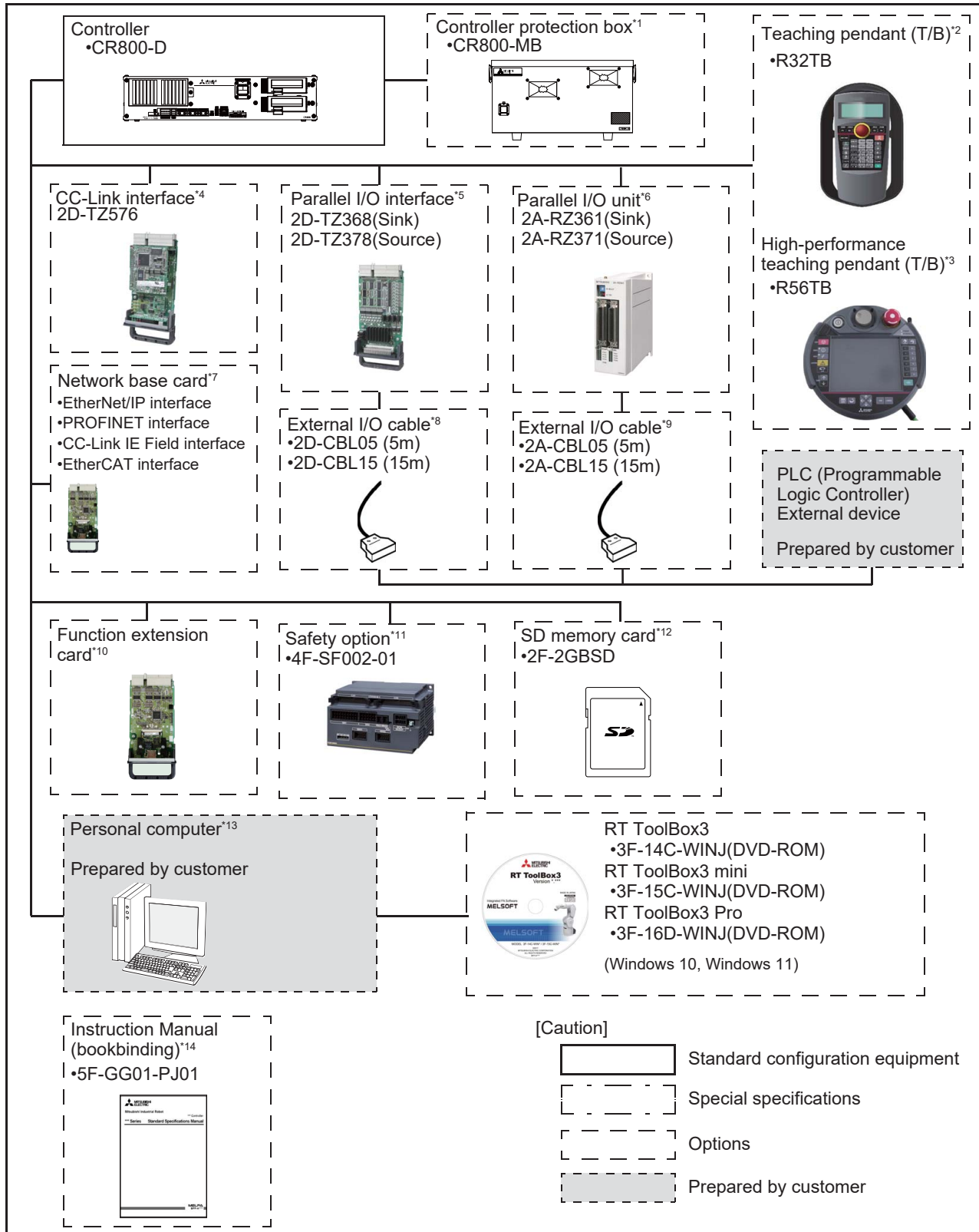

Fig.: Structural equipment (CR800-D)

- *1 Refer to the following page:
☞ Page 236 Controller protection box
- *2 Refer to the following page:
☞ Page 228 Teaching pendant (T/B)
- *3 Refer to the following page:
☞ Page 232 High-performance teaching pendant (T/B)
- *4 Refer to the following page:
☞ Page 265 CC-Link interface
- *5 Refer to the following page:
☞ Page 244 Parallel I/O interface
- *6 Refer to the following page:
☞ Page 253 Parallel I/O unit
- *7 Refer to ☞ Table: The list of the controller option equipment and special specification for details of each interface card.
- *8 Refer to the following page:
☞ Page 251 External I/O cable
- *9 Refer to the following page:
☞ Page 263 External I/O cable
- *10 Refer to the following page:
☞ Page 235 Function extension card
- *11 Refer to ☞ Table: The list of the controller option equipment and special specification for detail.
- *12 Refer to the following page:
☞ Page 267 SD memory card
- *13 Refer to ☞ Table: Table: Recommendation article of the USB cable for USB cable.
- *14 Refer to the following page:
☞ Page 243 Instruction Manual (bookbinding)

CR800-R controller

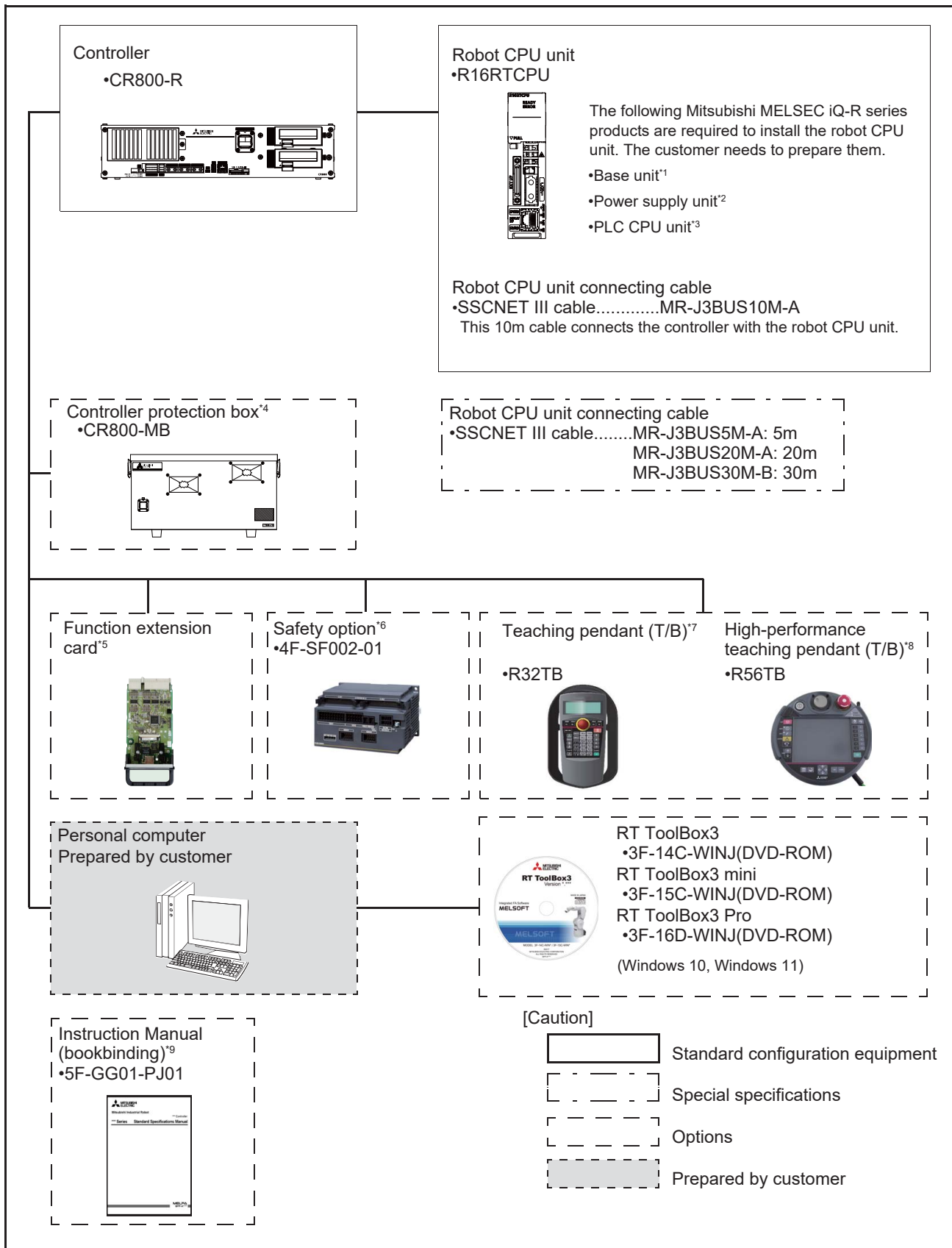

Fig.: Structural equipment (CR800-R)

*1 Refer to the following page:

☞ Page 39 Base unit

*2 Refer to the following page:

☞ Page 39 Power supply unit

- *3 Refer to the following page:
 - ☞ Page 39 PLC CPU unit
- *4 Refer to the following page:
 - ☞ Page 236 Controller protection box
- *5 Refer to the following page:
 - ☞ Page 235 Function extension card
- *6 Refer to ☞ Table: The list of the controller option equipment and special specification for detail.
- *7 Refer to the following page:
 - ☞ Page 228 Teaching pendant (T/B)
- *8 Refer to the following page:
 - ☞ Page 232 High-performance teaching pendant (T/B)
- *9 Refer to the following page:
 - ☞ Page 243 Instruction Manual (bookbinding)

■Base unit

Type name	Remarks
R35B	5 slots: for mounting MELSEC iQ-R series unit
R38B	8 slots: for mounting MELSEC iQ-R series unit
R312B	12 slots: for mounting MELSEC iQ-R series unit

■Power supply unit

Type name	Remarks
R61P	AC power supply unit. Input: AC100 to 240V, output: DC5V/6.5A
R62P	AC power supply unit. Input: AC100 to 240V, output: DC5V/3.5A, DC24V/0.6A
R63P	DC power supply unit. Input: DC24V, output: DC5V/6.5A
R64P	AC power supply module. Input: AC100 to 240V, output: DC5V/9A

■PLC CPU unit

Type name	Remarks
R00CPU	Program capacity: 10k steps, Elementary operation processing speed (LD command): 31.36ns
R01CPU	Program capacity: 15k steps, Elementary operation processing speed (LD command): 31.36ns
R02CPU	Program capacity: 20k steps, Elementary operation processing speed (LD command): 3.92ns
R04CPU	Program capacity: 40k steps, Elementary operation processing speed (LD command): 0.98ns
R08CPU	Program capacity: 80k steps, Elementary operation processing speed (LD command): 0.98ns
R16CPU	Program capacity: 160k steps, Elementary operation processing speed (LD command): 0.98ns
R32CPU	Program capacity: 320k steps, Elementary operation processing speed (LD command): 0.98ns
R120CPU	Program capacity: 1200k steps, Elementary operation processing speed (LD command): 0.98ns
R08SFPCPU-SET *1	Safety CPU, program capacity: 80k steps, safety function module (R6SFM) as a set
R16SFPCPU-SET *1	Safety CPU, program capacity: 160k steps, safety function module (R6SFM) as a set
R32SFPCPU-SET *1	Safety CPU, program capacity: 320k steps, safety function module (R6SFM) as a set
R120SFPCPU-SET *1	Safety CPU, program capacity: 1200k steps, safety function module (R6SFM) as a set

- *1 Supported versions
 - Robot controller: Ver.A5n or later
 - Safety CPU: Ver.20 or later

CR800-Q controller

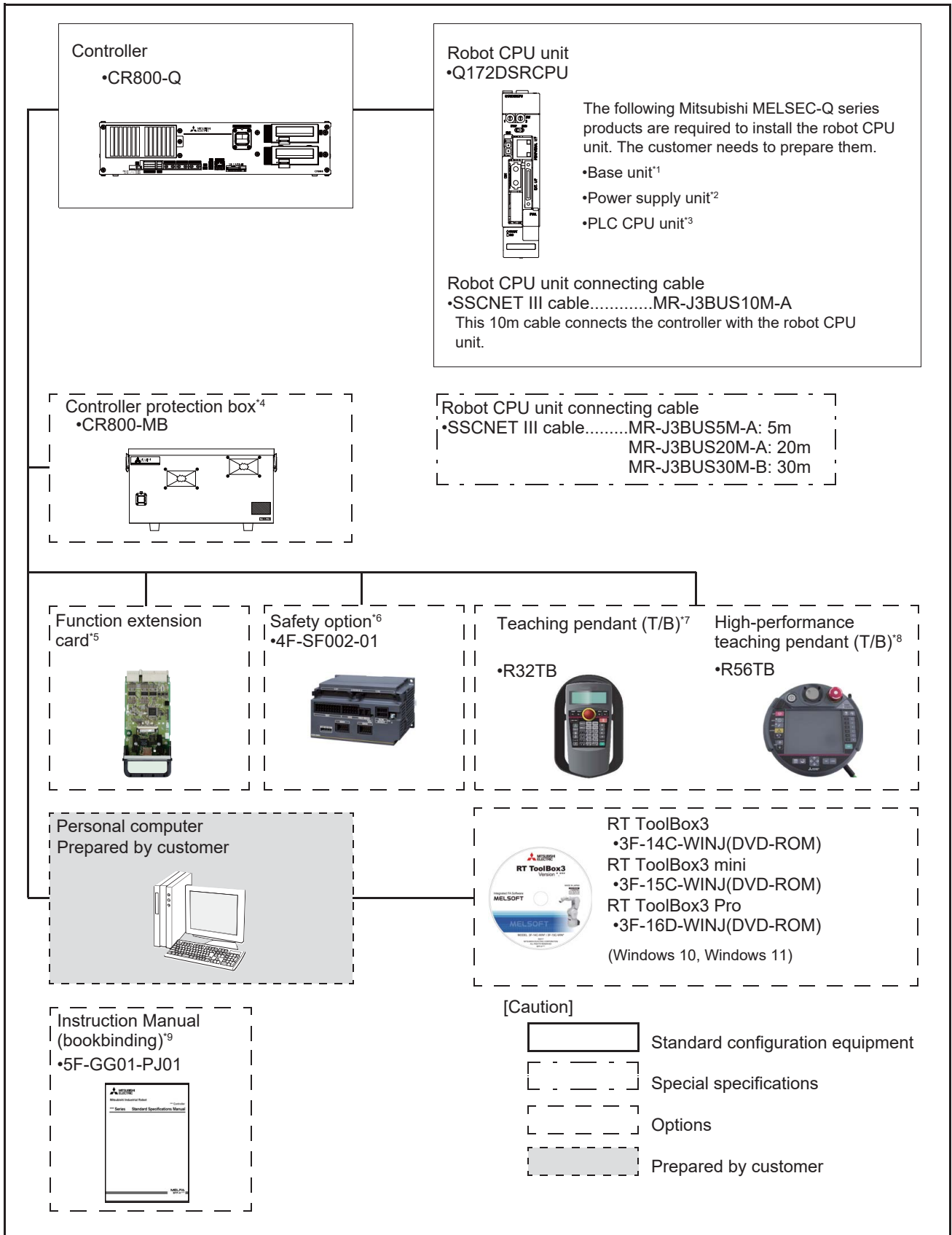

Fig.: Structural equipment (CR800-Q)

*1 Refer to the following page:

☞ Page 41 Base unit

*2 Refer to the following page:

☞ Page 41 Power supply unit

- *3 Refer to the following page:
☞ Page 41 PLC CPU unit
- *4 Refer to the following page:
☞ Page 236 Controller protection box
- *5 Refer to the following page:
☞ Page 235 Function extension card
- *6 Refer to ☞ Table: The list of the controller option equipment and special specification for detail.
- *7 Refer to the following page:
☞ Page 228 Teaching pendant (T/B)
- *8 Refer to the following page:
☞ Page 232 High-performance teaching pendant (T/B)
- *9 Refer to the following page:
☞ Page 243 Instruction Manual (bookbinding)

■Base unit

Type name	Remarks
Q35DB	5 slots: for mounting MELSEC-Q series unit
Q38DB	8 slots: for mounting MELSEC-Q series unit
Q312DB	12 slots: for mounting MELSEC-Q series unit

■Power supply unit

Type name	Remarks
Q61P	AC power supply unit. Input: AC100 to 240V, output: DC5V/6.5A
Q62P	AC power supply unit. Input: AC100 to 240V, output: DC5V/3A, DC24V/0.6A
Q63P	DC power supply unit. Input: DC24V, output: DC5V/3A, DC5V/6A
Q64PN	AC power supply module. Input: AC100 to 240V/AC200 to 240V, output: DC5V/8.5A

■PLC CPU unit

Type name	Remarks
Q03UDCPU	Program capacity: 30k steps, Elementary operation processing speed (LD command): 20ns
Q03UDECPU	Program capacity: 30k steps, Elementary operation processing speed (LD command): 20ns
Q04UDHCPU	Program capacity: 40k steps, Elementary operation processing speed (LD command): 9.5ns
Q04UDEHCPU	Program capacity: 40k steps, Elementary operation processing speed (LD command): 9.5ns
Q06UDHCPU	Program capacity: 60k steps, Elementary operation processing speed (LD command): 9.5ns
Q06UDEHCPU	Program capacity: 60k steps, Elementary operation processing speed (LD command): 9.5ns
Q10UDHCPU	Program capacity: 100k steps, Elementary operation processing speed (LD command): 9.5ns
Q10UDEHCPU	Program capacity: 100k steps, Elementary operation processing speed (LD command): 9.5ns
Q13UDHCPU	Program capacity: 130k steps, Elementary operation processing speed (LD command): 9.5ns
Q13UDEHCPU	Program capacity: 130k steps, Elementary operation processing speed (LD command): 9.5ns
Q20UDHCPU	Program capacity: 200k steps, Elementary operation processing speed (LD command): 9.5ns
Q20UDEHCPU	Program capacity: 200k steps, Elementary operation processing speed (LD command): 9.5ns
Q26UDHCPU	Program capacity: 260k steps, Elementary operation processing speed (LD command): 9.5ns
Q26UDEHCPU	Program capacity: 260k steps, Elementary operation processing speed (LD command): 9.5ns
Q50UDEHCPU	Program capacity: 500k steps, Elementary operation processing speed (LD command): 9.5ns
Q100UDEHCPU	Program capacity: 1000k steps, Elementary operation processing speed (LD command): 9.5ns
Q03UDVCPU	Program capacity: 30k steps, Elementary operation processing speed (LD command): 1.9ns
Q04UDVCPU	Program capacity: 40k steps, Elementary operation processing speed (LD command): 1.9ns
Q06UDVCPU	Program capacity: 60k steps, Elementary operation processing speed (LD command): 1.9ns
Q13UDVCPU	Program capacity: 130k steps, Elementary operation processing speed (LD command): 1.9ns
Q26UDVCPU	Program capacity: 260k steps, Elementary operation processing speed (LD command): 1.9ns

Function extension device

These devices (option) are used to extend the function of the robot.

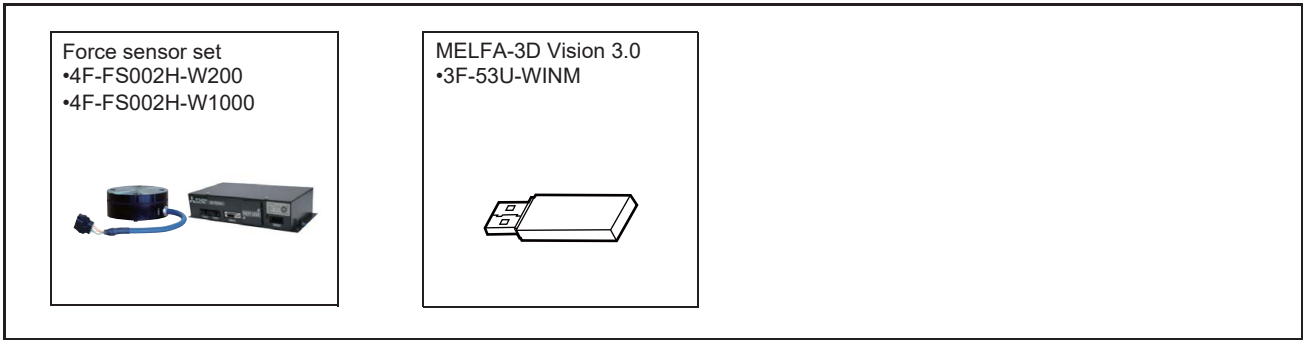

Fig.: Function extension device

1.6 Contents of the Option equipment and special specification

A list of all Optional equipment and special specifications are shown below.

List of the robot arm option equipment and special specification

Table: The list of the robot arm option equipment and special specification





Item	Type	Specifications	Classification *1	Description
Without machine cable	Special model number -SN	Machine cable (5m) not included. Otherwise, there is no change in the robot's standard specifications.	□	The special model number is affixed to the end of the model name. E.g.) RH-12FRH5535-D-SN
Stopper for changing the operating range	1F-DH-01	J1 axis stopper for changing the operating range	○	This must be installed by the customer. For RH-3FRH/6FRH series
	1F-DH-02	J1 axis stopper for changing the operating range	○	This must be installed by the customer. For RH-12FRH/20FRH series
	1S-DH-05J1	J1 axis stopper for changing the operating range Plus side / Minus side both are 90 degree. * Change both simultaneously Standard specification is +/- 225 degree.	○	This must be installed by the customer. For RH-3FRHR series
	1S-DH-05J2	J2 axis stopper for changing the operating range Plus side / Minus side both are 60 degree. * Change both simultaneously Standard specification is +/- 225 degree.	○	
Machine cable (replacement)	1F-□□UCBL-41	For fixing	○	"□□" in type shows the length of the cables as follows. 02=2m, 05=5m, 10=10m, 15=15m, 20=20m
	1F-□□LUCBL-41	For flexing	○	"□□" in type shows the length of the cables as follows. 10=10m, 15=15m, 20=20m
Solenoid valve set	1F-VD01-01/VD01E-01	1 set (Sink type)/(Source type)	○	The solenoid-valve set for the hand of the customer setup. For RH-3FRH/6FRH series.
	1F-VD02-01/VD02E-01	2 sets (Sink type)/(Source type)	○	
	1F-VD03-01/VD03E-01	3 sets (Sink type)/(Source type)	○	
	1F-VD04-01/VD04E-01	4 sets (Sink type)/(Source type)	○	
	1S-VD01-01/VD01E-01	1 set (Sink type)/(Source type)	○	The solenoid-valve set for the hand of the customer setup. For RH-12FRH/20FRH series.
	1S-VD02-01/VD02E-01	2 sets (Sink type)/(Source type)	○	
	1S-VD03-01/VD03E-01	3 sets (Sink type)/(Source type)	○	
	1S-VD04-01/VD04E-01	4 sets (Sink type)/(Source type)	○	
	1S-VD04-05/ 1S-VD04E-05	4 sets (Sink type)/(Source type) For Standard specification	○	The solenoid-valve set for the hand of the customer setup. For RH-3FRHR series.
	1S-VD04W-05/ 1S-VD04WE-05	4 sets (Sink type)/(Source type) For Clean/waterproof specification	○	
Hand input cable	1F-HC35C-01	Robot side: connector. Hand side: wire.	○	The cable is connected to the sensor by the customer. For RH-3FRH/6FRH series
	1F-HC35C-02	Robot side: connector. Hand side: wire.	○	The cable is connected to the sensor by the customer. For RH-12FRH/20FRH series
	1S-HC00S-01	Robot side: connector. Hand side: wire.	○	The cable is connected to the sensor by the customer. For RH-3FRHR series

Item	Type	Specifications	Classification *1	Description
Hand output cable	1F-GR60S-01	Robot side: connector. Hand side: wire	○	This cable can be used for the solenoid valve prepared by the customer. For RH-3FRH/6FRH/12FRH/20FRH series.
	1S-GR35S-02	Robot side: connector. Hand side: wire	○	This cable can be used for the solenoid valve prepared by the customer. For RH-3FRHR series
Hand curl tube	1E-ST0408C-300	For solenoid valve 4sets: $\phi 4 \times 8$	○	Curl type air tube For RH-3FRH/6FRH series
	1N-ST0608C-01	For solenoid valve 4sets: $\phi 6 \times 8$	○	Curl type air tube For RH-12FRH/20FRH series
Hand tube	1S-ST0304S	For solenoid valve 4sets: $\phi 3 \times 4$	○	The tube for piping the hand through the ball screw shaft by the customer. For RH-3FRHR series
External wiring/ piping box	1F-UT-BOX	For solenoid valve 4sets: $\phi 4 \times 8$	○	Box for external wiring of user wiring (hand I/O, hand curl tube) For RH-3FRH/6FRH series
	1F-UT-BOX-01	For solenoid valve 4sets: $\phi 6 \times 8$	○	Box for external wiring of user wiring (hand I/O, hand curl tube) For RH-12FRH/20FRH series
Internal wiring/piping set for hand	1F-HS304S-01	Hand input cable (four signal lines and two power lines), $\phi 3$ four hoses	○	Wiring/piping to pass in the shaft For RH-3FRH series Reducers ($\phi 4$ to $\phi 3$: 8pcs) are attached.
	1F-HS408S-01	Hand input cable (eight signal lines and two power lines), $\phi 4$ eight hoses	○	Wiring/piping to pass in the shaft For RH-6FRH series (200mm stroke)
	1F-HS408S-02	Hand input cable (eight signal lines and two power lines), $\phi 4$ eight hoses	○	Wiring/piping to pass in the shaft For RH-6FRH series (340mm stroke)
	1F-HS604S-01	Hand input cable (eight signal lines and two power lines), $\phi 6$ four hoses	○	Wiring/piping to pass in the shaft For RH-12FRH/20FRH series (350mm stroke)
	1F-HS604S-02	Hand input cable (eight signal lines and two power lines), $\phi 6$ four hoses	○	Wiring/piping to pass in the shaft For RH-12FRH/20FRH series (450mm stroke)

*1 ○: option, □: special specifications.

List of the controller option equipment and special specification

Table: The list of the controller option equipment and special specification

Item	Type	Specifications	Classification *1		Description
			CR800-D	CR800-R/Q	
Simple teaching pendant	R32TB	Cable length 7m	○	○	Equipped with a 3-position enable switch. IP65
	R32TB-15	Cable length 15m	○	○	
High-performance teaching pendant	R56TB	Cable length 7m	○	○	
	R56TB-15	Cable length 15m	○	○	
Parallel I/O Interface	2D-TZ368(Sink type)/2D-TZ378(Source type)	DO: 32 point DI: 32 point Insulated type output signal (0.1A/24V /point) Insulated type input signal (9mA/ 24V /point)	○	—	The card type external input-and-output. Interface. Install to the slot of controller.
External I/O cable (For Parallel I/O Interface)	2D-CBL05	5m	○	—	Use to connect the external peripheral device to the parallel input/output interface.
	2D-CBL15	15m	○	—	
Parallel I/O Unit	2A-RZ361(Sink type)/2A-RZ371(Source type)	DO: 32 point/ DI: 32 point Insulated type output signal (0.1A/24V /point) Insulated type input signal (7mA/ 24V /point)	○	—	The unit for expansion the external input/output. Electrical isolated Type (100mA/Point)
External I/O cable (For Parallel I/O Unit)	2A-CBL05	5m	○	—	Use to connect the external peripheral device to the parallel input/output unit
	2A-CBL15	15m	○	—	
CC-Link interface	2D-TZ576	Only Intelligent device station, Local station	○	—	For MELSEC PLC with CC-Link connection.
Network base card (EtherNet/IP interface)	2D-TZ535	Communication interface for mounting the Anybus CompactCom module manufactured by HMS. The customer needs to prepare the EtherNet/IP module (AB6314-B-218) manufactured by HMS.	○	—	Refer to  Network Base Card (2D-TZ535) INSTRUCTION MANUAL (BFP-A8872) for details.
Network base card (PROFINET interface)	2D-TZ535-PN	Communication interface for mounting the Anybus CompactCom module manufactured by HMS. The customer needs to prepare the PROFINET IO module (AB6489-B) manufactured by HMS.	○	—	Refer to  Network Base Card (2D-TZ535) INSTRUCTION MANUAL (BFP-A8872) for details.
Network base card (CC-Link IE Field interface)	2F-DQ535	Communication interface for mounting the Anybus CompactCom module manufactured by HMS. The customer needs to prepare the CC-Link IE Field module (AB6709-B-116) manufactured by HMS.	○	—	Refer to  Network Base Card (2F-DQ535/-EC) Instruction Manual (BFP-A3526) for details.
Network base card (EtherCAT interface)	2F-DQ535-EC	Communication interface for mounting the Anybus CompactCom module manufactured by HMS. The customer needs to prepare the EtherCAT module (AB6707-D-224) manufactured by HMS.	○	—	Refer to  Network Base Card (2F-DQ535/-EC) Instruction Manual (BFP-A3526) for details.
Function extension card	2F-DQ510	MELFA Smart Plus card pack (A-type)	○	○	Item to enable the software extension function MELFA Smart Plus.
	2F-DQ520	MELFA Smart Plus card pack (AB-type) Software version of controller: Ver. A3 or later	○	○	
	2F-DQ511	MELFA Smart Plus card (A-type)	○	○	
	2F-DQ521	MELFA Smart Plus card (B-type) Software version of controller: Ver. A3 or later	○	○	
SD memory card	2F-2GBSD	Memory card capacity 2GB.	○	—	

Item	Type	Specifications	Classification *1		Description
			CR800-D	CR800-R/Q	
Safety option	4F-SF002-01	Item to support the safety I/O.	<input type="radio"/>	<input type="radio"/>	Refer to CR800 series controller Robot Safety Option Instruction Manual (4F-SF002-01) (BFP-A3531) for details.
Controller protection box	C800-MB	IP54	<input type="radio"/>	<input type="radio"/>	The controller protection box is used to protect the controller from an oilmist or other operating environment.
RT ToolBox3	3F-14C-WINE	DVD-ROM	<input type="radio"/>	<input type="radio"/>	Windows 10, Windows 11 Supporting English. (With the simulation function)
RT ToolBox3 mini	3F-15C-WINE	DVD-ROM	<input type="radio"/>	<input type="radio"/>	Windows 10, Windows 11 Supporting English.
RT ToolBox3 Pro	3F-16D-WINE	DVD-ROM	<input type="radio"/>	<input type="radio"/>	Windows 10, Windows 11 Supporting English.
Robot CPU unit connection cable	MR-J3BUS <input type="checkbox"/> M-A	Cable length 5, 20m	—	<input type="checkbox"/>	For the servo communication between robot CPU and controller.
	MR-J3BUS30M-B	Cable length 30m	—	<input type="checkbox"/>	
Instruction Manual	5F-GG01-PE01	RH-FRH series	<input type="radio"/>	<input type="radio"/>	

*1 : option, : special specifications.

Function extension device

Table: The list of function extension device

Item	Type name	Specifications	Classification *1		Remarks
			CR800-D	CR800-R/Q	
Force sensor set	4F-FS002H-W200	A set of devices necessary for force sense control function, such as a force sensor, an interface unit, and support software.	○	○	Refer to CR800 series controller Force Sense Function Instruction Manual (BFP-A3510) for details.
	4F-FS002H-W1000				
MELFA-3D Vision 3.0	3F-53U-WINM	Software that connects a compact 3D vision sensor for robots to measure and recognize parts.	○	○	Refer to MELFA-3D Vision 3.0 Instruction Manual (BFP-A3749) for details.

*1 ○: option.

[Reference]

The recommendation products of the USB cable are shown below

Table: Recommendation article of the USB cable

Name	Type name	Supplier	Outside dimensions
USB cable (USB A type-USB mini B type)	GT09-C30USB-5P	mitsubishi electric system & service co., ltd.	Fig.: USB cable (GT09-C30USB-5P)
	MR-J3USBCBL3M	MITSUBISHI ELECTRIC CO., LTD.	Fig.: USB cable (MR-J3USBCBL3M)

⚠ CAUTION

Be careful to the USB cable to apply neither the static electricity nor the noise. Otherwise, it becomes the cause of malfunction.

⚠ CAUTION

Use the network equipments (personal computer, USB hub, LAN hub, etc) confirmed by manufacturer. The thing unsuitable for the FA environment (related with conformity, temperature or noise) exists in the equipments connected to USB.
When using network equipment, measures against the noise, such as measures against EMI and the addition of the ferrite core, may be necessary. Please fully confirm the operation by customer. Guarantee and maintenance of the equipment on the market (usual office automation equipment) cannot be performed..

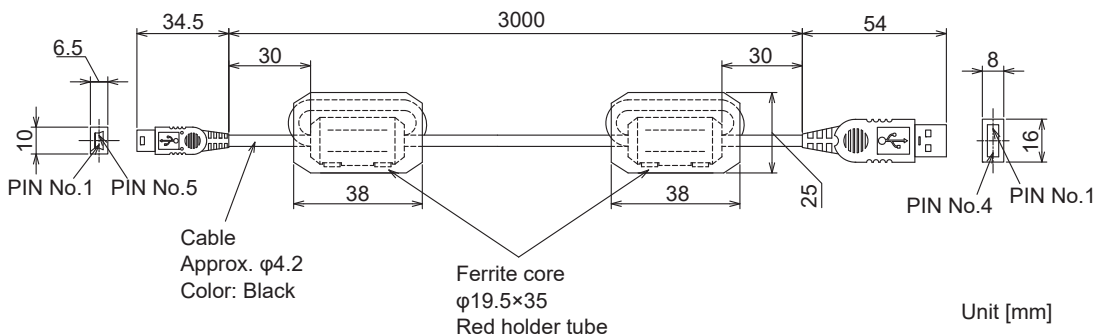

Fig.: USB cable (GT09-C30USB-5P)

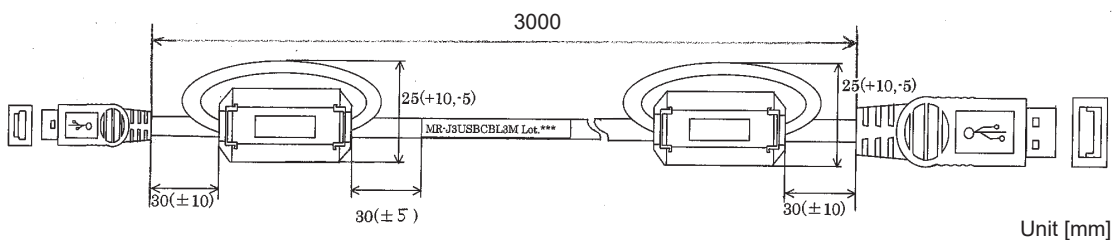

Fig.: USB cable (MR-J3USBCBL3M)

2 Robot arm

2.1 Standard specifications

Basic specifications

RH-3FRH series

Table: Standard specifications of robot arm

Item	Unit	Specifications			
Type		RH-3FHR3515	RH-3FHR4515	RH-3FHR5515	
Environment		Standard specification			
Installation posture		On floor			
Degree of freedom		4			
Structure		Horizontal articulated robot			
Drive system		AC servo motor			
Position detection method		Absolute encoder			
Motor capacity	J1	W	200		
	J2	W	100		
	J3 (Z)	W	100		
	J4 (θ axis)	W	50		
Brake		J1, J2, J4: no brake, J3: with brake			
Arm length	No.1 arm	mm	125	225	325
	No.2 arm	mm	225		
Max.reach radius(No.1+No.2)	mm	350	450	550	
Operating range	J1	deg	± 170		
	J2	deg	± 145		
	J3 (Z)	mm	150		
	J4 (θ axis)	deg	± 360		
Speed of motion *1	J1	deg/s	400		
	J2	deg/s	720		
	J3 (Z)	mm/s	1,100		
	J4 (θ axis)	deg/s	3,000		
Maximum horizontal composite speed *2	mm/s	6,800	7,500	8,300	
Cycle time *3	s	0.41	0.46	0.51	
Load	Rating	kg	1		
	Maximum	(N)	3		
Z axis pressing force *4	Maximum	N	82		
Allowable inertia	Rating	kg·m ²	0.005		
	Maximum		0.06		
Pose repeatability *5	X-Y direction	mm	± 0.010	± 0.010	± 0.012
	J3 (Z)	mm	± 0.010		
	J4 (θ axis)	deg	± 0.004		
Ambient temperature *6	°C	0 to 40			
Mass	kg	29	32		
Tool wiring		<ul style="list-style-type: none"> • Input 8 points/Output 8 points, (total 20 cores) • Dedicated signal cable for multifunctional hand (Two cores + Power cable two cores) • Ethernet cable one cable (100BASE-TX, eight cores) *7 			
Tool pneumatic pipes		Primary: $\phi 6 \times 2$, Secondary: $\phi 4 \times 8$ *8			
Supply pressure	MPa	0.5 \pm 10%			
Protection specification *9		IP20			

Item	Unit	Specifications
Painting color		Light gray (Equivalent to Munsell: 0.6B7.6/0.2, PANTONE: 428C)

- *1 The maximum speed is the value which applied MvTune2 (high-speed movement mode).
- *2 At the maximum speed on the X-Y flat surface in the robot's control point, it is obtained with each speed of J1, J2, and J4. The control point is the position offset by the rated inertia from the flange.
- *3 The value of the following movement which applied MvTune2 (high-speed movement mode) with the carrying mass of 2kg.
 - The cycle time may increase with the case where the positioning accuracy of the work etc. is necessary, or by the moving position.

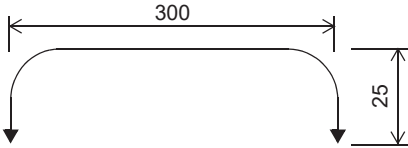

- *4 This is the downwards pressing force that occurs at the end of the load when the maximum load is on board and the J1, J2 and J4 axis are in their resting state. Please operate at this level or below. When pressing for long periods of time, an excess load error may occur. Please operate in a manner that does not cause errors.
- *5 The pose repeatability details are given in [Page 63 Pose repeatability](#).
- *6 Sets the robot's operating environmental temperature as parameter OLTMX. Corresponding to the environment, the continuous control action performance and the overload-protection function are optimized. (Refers to "Optimizing the overload level" described in "Chapter 5 Functions set with parameters" of [CR800 Series Controller INSTRUCTION MANUAL Detailed explanations of functions and operations \(BFP-A3478\)](#) of functions and operations for details.)
- *7 The 8-wire cable designated for LAN wiring can also be used for backup wiring.
- *8 The $\phi 4$ secondary piping can be obtained with the electromagnetic valve (option). Details regarding the electromagnetic valve (optional) are shown on [Page 164 Solenoid valve set](#).
- *9 The protection specification details are given in [Page 77 Protection specifications](#).

Table: Standard specifications of robot arm (Clean specification)

Item	Unit	Specifications			
Type		RH-3FRH3512C	RH-3FRH4512C	RH-3FRH5512C	
Environment		Clean specification			
Installation posture		On floor			
Degree of freedom		4			
Structure		Horizontal articulated robot			
Drive system		AC servo motor			
Position detection method		Absolute encoder			
Motor capacity	J1	W	200		
	J2	W	100		
	J3 (Z)	W	100		
	J4 (θaxis)	W	50		
Brake		J1, J2, J4: no brake, J3: with brake			
Arm length	No.1 arm	mm	125	225	325
	No.2 arm	mm	225		
Max.reach radius(No.1+No.2)	mm	350	450	550	
Operating range	J1	deg	±170		
	J2	deg	±145		
	J3 (Z)	mm	120		
	J4 (θaxis)	deg	±360		
Speed of motion *1	J1	deg/s	420		
	J2	deg/s	720		
	J3 (Z)	mm/s	1,100		
	J4 (θaxis)	deg/s	3,000		
Maximum horizontal composite speed *2	mm/s	6,800	7,500	8,300	
Cycle time *3	s	0.41	0.46	0.51	
Load	Rating	kg	1		
	Maximum	(N)	3		
Z axis pressing force *4	Maximum	N	82		
Allowable inertia	Rating	kg·m ²	0.005		
	Maximum		0.06		
Pose repeatability *5	X-Y direction	mm	±0.010	±0.010	±0.012
	J3 (Z)	mm	±0.010		
	J4 (θaxis)	deg	±0.004		
Ambient temperature *6	°C	0 to 40			
Mass	kg	29	32		
Tool wiring		<ul style="list-style-type: none"> • Input 8 points/Output 8 points, (total 20 cores) • Dedicated signal cable for multifunctional hand (Two cores + Power cable two cores) • Ethernet cable one cable (100BASE-TX, eight cores) *7 			
Tool pneumatic pipes		Primary: φ6 x 2, Secondary: φ4 x 8 *8			
Supply pressure	MPa	0.5±10%			
Protection specification *9		Clean specification: ISO class 3			
Painting color		Light gray (Equivalent to Munsell: 0.6B7.6/0.2, PANTONE: 428C)			





*1 The maximum speed is the value which applied MvTune2 (high-speed movement mode).

*2 At the maximum speed on the X-Y flat surface in the robot's control point, it is obtained with each speed of J1, J2, and J4. The control point is the position offset by the rated inertia from the flange.

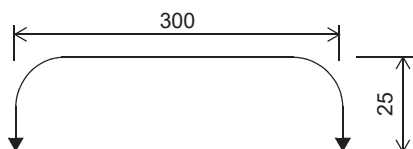
*3 The value of the following movement which applied MvTune2 (high-speed movement mode) with the carrying mass of 2kg.

•The cycle time may increase with the case where the positioning accuracy of the work etc. is necessary, or by the moving position.



- *4 This is the downwards pressing force that occurs at the end of the load when the maximum load is on board and the J1, J2 and J4 axis are in their resting state. Please operate at this level or below. When pressing for long periods of time, an excess load error may occur. Please operate in a manner that does not cause errors.
- *5 The pose repeatability details are given in  Page 63 Pose repeatability.
- *6 Sets the robot's operating environmental temperature as parameter OLTMX. Corresponding to the environment, the continuous control action performance and the overload-protection function are optimized. (Refers to "Optimizing the overload level" described in "Chapter 5 Functions set with parameters" of  CR800 Series Controller INSTRUCTION MANUAL Detailed explanations of functions and operations (BFP-A3478) of functions and operations for details.)
- *7 The 8-wire cable designated for LAN wiring can also be used for backup wiring.
- *8 The $\phi 4$ secondary piping can be obtained with the electromagnetic valve (option). Details regarding the electromagnetic valve (optional) are shown on  Page 164 Solenoid valve set.
- *9 The details of the clean specifications are described in  Page 80 Clean specifications. The conditions necessary to guarantee cleanliness are as follows: clean room down flow greater than 0.3 m/s, robot internal suction of 30 to 50 L/min, and installation of an exhaust duct at the rear of the robot's main base. A $\phi 8$ joint has been prepared at the rear of the base for suction. The protection specification details are given in  Page 77 Protection specifications.

RH-6FRH series

Table: Standard specifications of robot arm

Item		Unit	Specifications		
Type ^{*1}			RH-6FRH3520/3534 RH-6FRH3520C/3534C RH-6FRH3520M/3534M	RH-6FRH4520/4534 RH-6FRH4520C/4534C RH-6FRH4520M/4534M	RH-6FRH5520/5534 RH-6FRH5520C/5534C RH-6FRH5520M/5534M
Environment			Blank: Standard specification C: Clean specification M: Oil mist specification ^{*2}		
Installation posture			On floor		
Degree of freedom			4		
Structure			Horizontal articulated robot		
Drive system			AC servo motor		
Position detection method			Absolute encoder		
Motor capacity	J1	W	750		
	J2	W	400		
	J3 (Z)	W	200		
	J4 (θaxis)	W	100		
Brake			J1, J2, J4: no brake, J3: with brake		
Arm length	No.1 arm	mm	125	225	325
	No.2 arm	mm	225		
Max.reach radius(No.1+No.2)		mm	350	450	550
Operating range	J1	deg	±170		
	J2	deg	±145		
	J3 (Z)	mm	RH-6FRH**20/**20C/**20M: 200 (+133 to +333) RH-6FRH**34: 340 (-7 to +333) RH-6FRH**34C/**34M: 340 (-43 to +297)		
	J4 (θaxis)	deg	±360		
Speed of motion ^{*3}	J1	deg/s	400		
	J2	deg/s	670		
	J3 (Z)	mm/s	2,400		
	J4 (θaxis)	deg/s	2,500		
Maximum horizontal composite speed ^{*4}		mm/s	6,900	7,600	8,300
Cycle time ^{*5}		s	0.29		
Load	Rating	kg	3		
	Maximum	(N)	6		
Z axis pressing force ^{*6}	Maximum	N	165		
Allowable inertia	Rating	kg·m ²	0.01		
	Maximum		0.12		
Pose repeatability ^{*7}	X-Y direction	mm	±0.010	±0.010	±0.012
	J3 (Z)	mm	±0.010		
	J4 (θaxis)	deg	±0.004		
Ambient temperature ^{*8}		°C	0 to 40		
Mass		kg	36	37	
Tool wiring			<ul style="list-style-type: none"> • Input 8 points/Output 8 points, (total 20 cores) • Dedicated signal cable for multifunctional hand (Two cores + Power cable two cores) • Ethernet cable one cable (100BASE-TX, eight cores) ^{*9} 		
Tool pneumatic pipes			Primary: φ6 x 2, Secondary: φ4 x 8 ^{*10}		
Supply pressure		MPa	0.5±10%		
Protection specification ^{*11}			Standard specification: IP20 Clean specification: ISO class 3 ^{*12} Oil mist specification: IP65 ^{*13} ^{*14}		
Painting color			Light gray (Equivalent to Munsell: 0.6B7.6/0.2, PANTONE: 428C)		

- *1 The table is joint writing on the general environment and clean and oil mist (IP65) specification. If the type ends in a letter C, this corresponds to the clean specification, and where it ends in a letter M, it corresponds to the mist specification. The type in which operating range of J3 axis (Z) is 200mm and 340mm are shown together.
- *2 The oil-mist specification of CE specification is the standards.
- *3 The maximum speed is the value which applied MvTune2 (high-speed movement mode).
- *4 At the maximum speed on the X-Y flat surface in the robot's control point, it is obtained with each speed of J1, J2, and J4. The control point is the position offset by the rated inertia from the flange.
- *5 The value of the following movement which applied MvTune2 (high-speed movement mode) with the carrying mass of 2kg.
 - The cycle time may increase with the case where the positioning accuracy of the work etc. is necessary, or by the moving position.

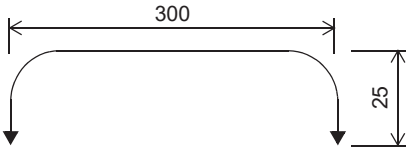

- *6 This is the downwards pressing force that occurs at the end of the load when the maximum load is on board and the J1, J2 and J4 axis are in their resting state. Please operate at this level or below. When pressing for long periods of time, an excess load error may occur. Please operate in a manner that does not cause errors.
- *7 The pose repeatability details are given in [Page 63 Pose repeatability](#)
- *8 Sets the robot's operating environmental temperature as parameter OLTMX. Corresponding to the environment, the continuous control action performance and the overload-protection function are optimized. (Refers to "Optimizing the overload level" described in "Chapter 5 Functions set with parameters" of [CR800 Series Controller INSTRUCTION MANUAL Detailed explanations of functions and operations \(BFP-A3478\)](#) of functions and operations for details.)
- *9 The 8-wire cable designated for LAN wiring can also be used for backup wiring.
- *10 The $\phi 4$ secondary piping can be obtained with the electromagnetic valve (option). Details regarding the electromagnetic valve (optional) are shown on [Page 164 Solenoid valve set](#).
- *11 The protection specification details are given in [Page 77 Protection specifications](#).
- *12 The details of the clean specifications are described in [Page 80 Clean specifications](#). The conditions necessary to guarantee cleanliness are as follows: clean room down flow 0.3 m/s or greater, robot internal suction of 30-50L/min and installation of an exhaust duct at the rear of the robot's main base. A $\phi 8$ joint is prepared at the rear of the base for suction.
- *13 Direct jet flow to the bellows section is not included.
- *14 If you use the controller in oil mist or similar environments, use the controller protection box to protect the controller from the operation environment. A robot equipped with the controller protection box as standard is available.

RH-12FRH series

Table: Standard specifications of robot arm

Item		Unit	Specifications		
Type ^{*1}			RH-12FRH5535/5545 RH-12FRH5535C/5545C RH-12FRH5535M/5545M	RH-12FRH7035/7045 RH-12FRH7035C/7045C RH-12FRH7035M/7045M	RH-12FRH8535/8545 RH-12FRH8535C/8545C RH-12FRH8535M/8545M
Environment			Blank: Standard specification C: Clean specification M: Oil mist specification		
Installation posture			On floor		
Degree of freedom			4		
Structure			Horizontal articulated robot		
Drive system			AC servo motor		
Position detection method			Absolute encoder		
Motor capacity	J1	W	750		
	J2	W	750		
	J3 (Z)	W	400		
	J4 (θaxis)	W	200		
Brake			J1, J2, J4: no brake, J3: with brake		
Arm length	No.1 arm	mm	225	375	525
	No.2 arm	mm	325		
Max.reach radius(No.1+No.2)		mm	550	700	850
Operating range	J1	deg	±170		
	J2	deg	±145		±153
	J3 (Z)	mm	RH-12FRH**35/**35C/**35M: 350 (-10~+340) RH-12FRH**45/**45C/**45M: 450 (-110~+340)		
	J4 (θaxis)	deg	±360		
Speed of motion ^{*2}	J1	deg/s	420	280	
	J2	deg/s	450		
	J3 (Z)	mm/s	2,800		
	J4 (θaxis)	deg/s	2,400		
Maximum horizontal composite speed ^{*3}		mm/s	11,435	12,535	11,350
Cycle time ^{*4}		s	0.30		
Load	Rating	kg	3		
	Maximum	(N)	12		
Z axis pressing force ^{*5}	Maximum	N	200		
Allowable inertia	Rating	kg·m ²	0.025		
	Maximum		0.3		
Pose repeatability ^{*6}	X-Y direction	mm	±0.012	±0.015	
	J3 (Z)	mm	±0.010		
	J4 (θaxis)	deg	±0.005		
Ambient temperature ^{*7}		°C	0 to 40		
Mass	kg	65	67	69	
Tool wiring			<ul style="list-style-type: none"> • Input 8 points/Output 8 points, (total 20 cores) • Dedicated signal cable for multifunctional hand (Two cores + Power cable two cores) • Ethernet cable one cable (100BASE-TX, eight cores) ^{*8} 		
Tool pneumatic pipes			Primary: φ6 x 2, Secondary: φ6 x 8 ^{*9}		
Supply pressure		MPa	0.5±10%		
Protection specification ^{*10}			Standard specification: IP20 Clean specification: ISO class 3 ^{*11} Oil mist specification: IP65 ^{*12} ^{*13}		
Painting color			Light gray (Equivalent to Munsell: 0.6B7.6/0.2, PANTONE: 428C)		

^{*1} The table is joint writing on the general environment and clean and oil mist (IP65) specification. If the type ends in a letter C, this corresponds to the clean specification, and where it ends in a letter M, it corresponds to the mist specification. The type in which operating range of J3 axis (Z) is 350mm and 450mm are shown together.

- *2 The maximum speed is the value which applied MvTune2 (high-speed movement mode).
- *3 At the maximum speed on the X-Y flat surface in the robot's control point, it is obtained with each speed of J1, J2, and J4. The control point is the position offset by the rated inertia from the flange.
- *4 The value of the following movement which applied MvTune2 (high-speed movement mode) with the carrying mass of 2kg.
 - The cycle time may increase with the case where the positioning accuracy of the work etc. is necessary, or by the moving position.

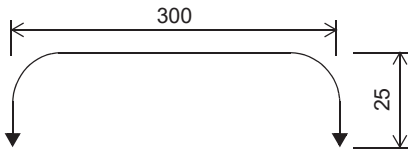

- *5 This is the downwards pressing force that occurs at the end of the load when the maximum load is on board and the J1, J2 and J4 axis are in their resting state. Please operate at this level or below. When pressing for long periods of time, an excess load error may occur. Please operate in a manner that does not cause errors.
- *6 The pose repeatability details are given in [Page 63 Pose repeatability](#).
- *7 Sets the robot's operating environmental temperature as parameter OLTMX. Corresponding to the environment, the continuous control action performance and the overload-protection function are optimized. (Refers to "Optimizing the overload level" described in "Chapter 5 Functions set with parameters" of [CR800 Series Controller INSTRUCTION MANUAL Detailed explanations of functions and operations \(BFP-A3478\)](#) of functions and operations for details.)
- *8 The 8-wire cable designated for LAN wiring can also be used for backup wiring.
- *9 The $\phi 6$ secondary piping can be obtained with the electromagnetic valve (option). Details regarding the electromagnetic valve (optional) are shown on [Page 164 Solenoid valve set](#).
- *10 The protection specification details are given in [Page 77 Protection specifications](#).
- *11 The details of the clean specifications are described in [Page 80 Clean specifications](#). The conditions necessary to guarantee cleanliness are as follows: clean room down flow 0.3 m/s or greater, robot internal suction of 60-140L/min and installation of an exhaust duct at the rear of the robot's main base. A $\phi 8$ joint is prepared at the rear of the base for suction.
- *12 Direct jet flow to the bellows section is not included.
- *13 If you use the controller in oil mist or similar environments, use the controller protection box to protect the controller from the operation environment. A robot equipped with the controller protection box as standard is available.

RH-20FRH series

Table: Standard specifications of robot arm

Item		Unit	Specifications	
Type ^{*1}			RH-20FRH8535/8545 RH-20FRH8535C/8545C RH-20FRH8535M/8545M	RH-20FRH10035/10045 RH-20FRH10035C/10045C RH-20FRH10035M/10045M
Environment			Blank: Standard specification C: Clean specification M: Oil mist specification	
Installation posture			On floor	
Degree of freedom			4	
Structure			Horizontal articulated robot	
Drive system			AC servo motor	
Position detection method			Absolute encoder	
Motor capacity	J1	W	750	
	J2	W	750	
	J3 (Z)	W	400	
	J4 (θaxis)	W	200	
Brake			J1, J2, J4: no brake, J3: with brake	
Arm length	No.1 arm	mm	525	
	No.2 arm	mm	325	475
Max.reach radius(No.1+No.2)		mm	850	1,000
Operating range	J1	deg	±170	
	J2	deg	±153	
	J3 (Z)	mm	RH-20FRH**35/**35C/**35M: 350 (-10~+340) RH-20FRH**45/**45C/**45M: 450 (-110~+340)	
	J4 (θaxis)	deg	±360	
Speed of motion ^{*2}	J1	deg/s	280	
	J2	deg/s	450	
	J3 (Z)	mm/s	2,400	
	J4 (θaxis)	deg/s	1,700	
Maximum horizontal composite speed ^{*3}		mm/s	11,372	13,283
Cycle time ^{*4}		s	0.30	0.36
Load	Rating	kg	5	
	Maximum	(N)	20	
Z axis pressing force ^{*5}	Maximum	N	230	
Allowable inertia	Rating	kg·m ²	0.065	
	Maximum		1.05 ^{*6}	
Pose repeatability ^{*7}	X-Y direction	mm	±0.015	±0.020
	J3 (Z)	mm	±0.010	
	J4 (θaxis)	deg	±0.005	
Ambient temperature ^{*8}		°C	0 to 40	
Mass		kg	75	77
Tool wiring			<ul style="list-style-type: none"> • Input 8 points/Output 8 points, (total 20 cores) • Dedicated signal cable for multifunctional hand (Two cores + Power cable two cores) • Ethernet cable one cable (100BASE-TX, eight cores) ^{*9} 	
Tool pneumatic pipes			Primary: φ6 x 2, Secondary: φ6 x 8 ^{*10}	
Supply pressure		MPa	0.5±10%	
Protection specification ^{*11}			Standard specification: IP20 Clean specification: ISO class 3 ^{*12} Oil mist specification: IP65 ^{*13} ^{*14}	
Painting color			Light gray (Equivalent to Munsell: 0.6B7.6/0.2, PANTONE: 428C)	

^{*1} The table is joint writing on the general environment and clean and oil mist (IP65) specification. If the type ends in a letter C, this corresponds to the clean specification, and where it ends in a letter M, it corresponds to the mist specification. The type in which operating range of J3 axis (Z) is 350mm and 450mm are shown together.

- *2 The maximum speed is the value which applied MvTune2 (high-speed movement mode).
- *3 At the maximum speed on the X-Y flat surface in the robot's control point, it is obtained with each speed of J1, J2, and J4. The control point is the position offset by the rated inertia from the flange.
- *4 The value of the following movement which applied MvTune2 (high-speed movement mode) with the carrying mass of 2kg.
 - The cycle time may increase with the case where the positioning accuracy of the work etc. is necessary, or by the moving position.

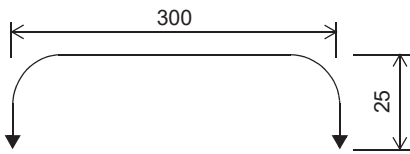

- *5 This is the downwards pressing force that occurs at the end of the load when the maximum load is on board and the J1, J2 and J4 axis are in their resting state. Please operate at this level or below. When pressing for long periods of time, an excess load error may occur. Please operate in a manner that does not cause errors.
- *6 When offset hand is used, the adjustment of moving speed and acceleration/deceleration speeds may be the Required. Refers to it, because the details is shown in [Page 64 Mass capacity](#).
- *7 The pose repeatability details are given in [Page 63 Pose repeatability](#).
- *8 Sets the robot's operating environmental temperature as parameter OLTMX. Corresponding to the environment, the continuous control action performance and the overload-protection function are optimized. (Refers to "Optimizing the overload level" described in "Chapter 5 Functions set with parameters" of [CR800 Series Controller INSTRUCTION MANUAL Detailed explanations of functions and operations \(BFP-A3478\)](#) of functions and operations for details.)
- *9 The 8-wire cable designated for LAN wiring can also be used for backup wiring.
- *10 The $\phi 6$ secondary piping can be obtained with the electromagnetic valve (option). Details regarding the electromagnetic valve (optional) are shown on [Page 164 Solenoid valve set](#).
- *11 The protection specification details are given in [Page 77 Protection specifications](#).
- *12 The details of the clean specifications are described in [Page 80 Clean specifications](#). The conditions necessary to guarantee cleanliness are as follows: clean room down flow 0.3 m/s or greater, robot internal suction of 60-140L/min and installation of an exhaust duct at the rear of the robot's main base. A $\phi 8$ joint is prepared at the rear of the base for suction.
- *13 Direct jet flow to the bellows section is not included.
- *14 If you use the controller in oil mist or similar environments, use the controller protection box to protect the controller from the operation environment. A robot equipped with the controller protection box as standard is available.

RH-3FRHR series

Table: Standard specifications of robot arm

Item	Unit	Specifications		
Type *1		RH-3FRHR3515	RH-3FRHR3512C	RH-3FRHR3512W
Environment		Standard specification	Clean specification	Waterproof specification
Installation posture		Hanging		
Degree of freedom		4		
Structure		Horizontal articulated robot		
Drive system		AC servo motor		
Position detection method		Absolute encoder		
Motor capacity	J1	W	750	
	J2	W	200	
	J3 (Z)	W	200	
	J4 (θ axis)	W	100	
Brake		J1, J2, J4: no brake J3: with brake		
Arm length	No.1 arm	mm	175	
	No.2 arm	mm	175	
Max.reach radius(No.1+No.2)		mm	350	
Operating range	J1	deg	± 225	
	J2	deg	± 225	
	J3 (Z)	mm	150	120
	J4 (θ axis)	deg	± 720	
Speed of motion *2	J1	deg/s	672	
	J2	deg/s	708	
	J3 (Z)	mm/s	1,500	
	J4 (θ axis)	deg/s	3,146	
Maximum horizontal composite speed *3		mm/s	6,267	
Cycle time *4		s	0.32	
Load	Rating	kg	1	
	Maximum	(N)	3	
Allowable inertia	Rating	kg·m ²	0.005	
	Maximum		0.05 *5	
Pose repeatability *6	X-Y direction	mm	± 0.01	
	J3 (Z)	mm	± 0.01	
	J4 (θ axis)	deg	± 0.01	
Ambient temperature *7		°C	0 to 40	
Mass		kg	24	28
Tool wiring		Input 8 points/Output 8 points, eight spare wires		
Tool pneumatic pipes		Primary: $\phi 6 \times 2$, Secondary: $\phi 4 \times 8$ *8		
Supply pressure		MPa	0.5 \pm 10%	
Protection specification *9		General-purpose environment: IP20	Clean: ISO class 5 *10	Waterproof: IP65 *11
Painting color		Not painting. Plating (silver)		

*1 The table is joint writing on the general environment and clean and waterproof (IP65) specification. If the type ends in a letter C, this corresponds to the clean specification, and where it ends in a letter W, it corresponds to the waterproof specification.

*2 The maximum speed is the value which applied MvTune2 (high-speed movement mode).

*3 At the maximum speed on the X-Y flat surface in the robot's control point, it is obtained with each speed of J1, J2, and J4. The control point is the position offset by the rated inertia from the flange.

Although based on specified speed, speed drops generally. Refer to  Page 75 About moving speed at singular point and near singular point. (RH-3FRHR series) for details.

- *4 The value of the following movement which applied MvTune2 (high-speed movement mode) with the carrying mass of 1kg.
 - The cycle time may increase with the case where the positioning accuracy of the work etc. is necessary, or by the moving position.

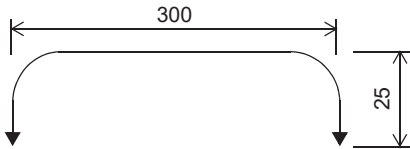

•The robot's moving time is influenced by the posture etc. As reference, the reduction method of cycle time is shown in [☞ Supplementary explanation 1](#)]: The setting which shortens execution time.

- *5 When offset hand is used, the adjustment of moving speed and acceleration/deceleration speeds may be the Required. Refers to it, because the details is shown in [☞ Page 64 Mass capacity](#).
- *6 The pose repeatability details are given in [☞ Page 63 Pose repeatability](#).
- *7 Sets the robot's operating environmental temperature as parameter OLTMX. Corresponding to the environment, the continuous control action performance and the overload-protection function are optimized. (Refers to "Optimizing the overload level" described in "Chapter 5 Functions set with parameters" of [☞ CR800 Series Controller INSTRUCTION MANUAL Detailed explanations of functions and operations \(BFP-A3478\)](#) of functions and operations for details.)
- *8 The $\phi 4$ secondary piping can be obtained with the electromagnetic valve (option). Details regarding the electromagnetic valve (optional) are shown on [☞ Page 164 Solenoid valve set](#).
- *9 The protection specification details are given in [☞ Page 77 Protection specifications](#).
- *10 The details of the clean specifications are described in [☞ Page 80 Clean specifications](#). Protection of the cleanness of the robot is required if the down flow in a clean room is 0.3 m/s or more and robot internal suction is 30-50 L/min. A $\phi 8$ joint is prepared at the base rear part for suction.
- *11 Direct jet flow to the bellows section is not included.

The counter-force applied to the installation surface

The counter-force applied to the installation surface for the strength design of the robot installation surface is shown.

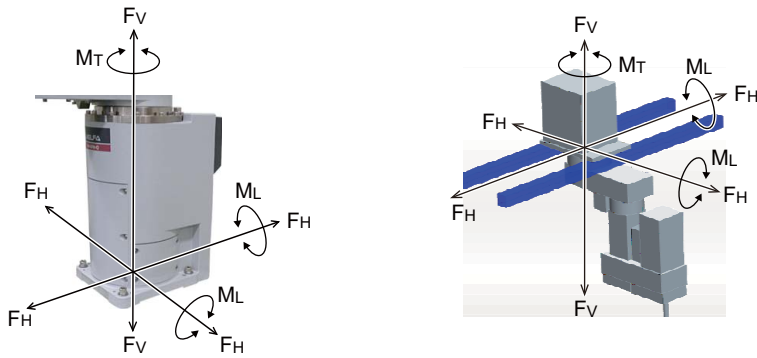

Value of each counter-force

Item	Unit	Value
RH-3FRH series		
Falls moment: M_L	N•m	240
Torsion moment: M_T	N•m	255
Horizontal translation force: F_H	N	810
Vertical translation force: F_V	N	380
RH-6FH series		
Falls moment: M_L	N•m	1,640
Torsion moment: M_T	N•m	710
Horizontal translation force: F_H	N	1,653
Vertical translation force: F_V	N	2,318
RH-12FRH/20FRH series		
Falls moment: M_L	N•m	3,190
Torsion moment: M_T	N•m	1,840
Horizontal translation force: F_H	N	2,240
Vertical translation force: F_V	N	2,500
RH-3FRHR series		
Falls moment: M_L	N•m	380
Torsion moment: M_T	N•m	410
Horizontal translation force: F_H	N	920
Vertical translation force: F_V	N	570

RH-3FRHR installation stage

RH-3FRHR is the robot which hangs. Please manufacture the stage by the customer as shown below, and install the robot. As an example of the installation stage, the stage using the iron (cheap) and the stage using the aluminum (easy to process) are shown. Since the product made from the aluminum has strengthened reinforcement, both have the almost same weight.

Example which uses the iron material

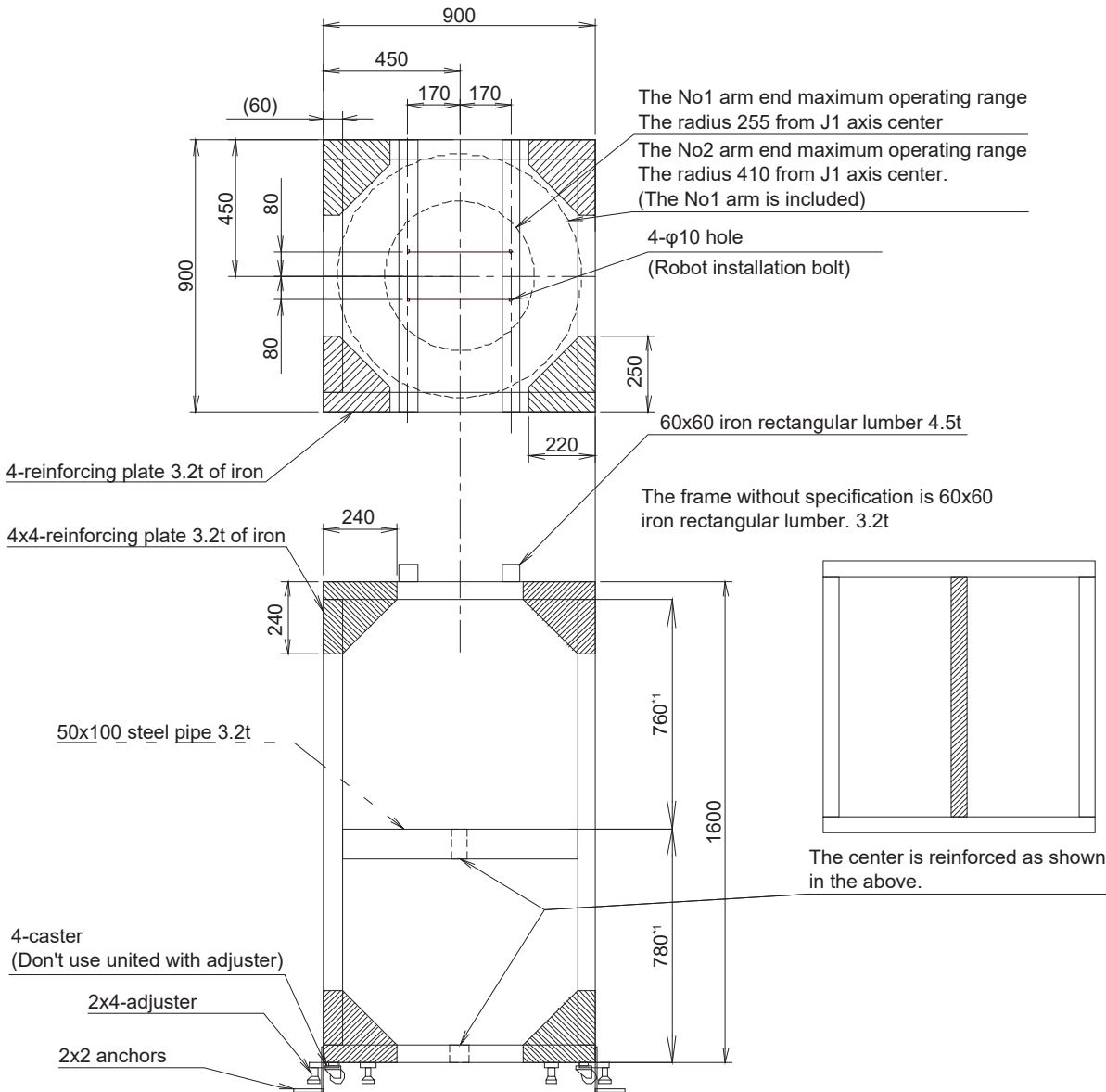

- Note 1) The gross weight of this stage is about 200kg.
- Note 2) This stage is an example. Please design based on the conditions of the system.
- Note 3) Fixing the stage to the floor by anchor etc. If the center of gravity of the stage is in the high position, the stage may fall by movement of the robot.

Fig.: Installation stage (Example of iron-material use)

*1 Please arrange operations height based on peripheral equipment, such as the work-piece and the hand.

Example which uses the aluminum

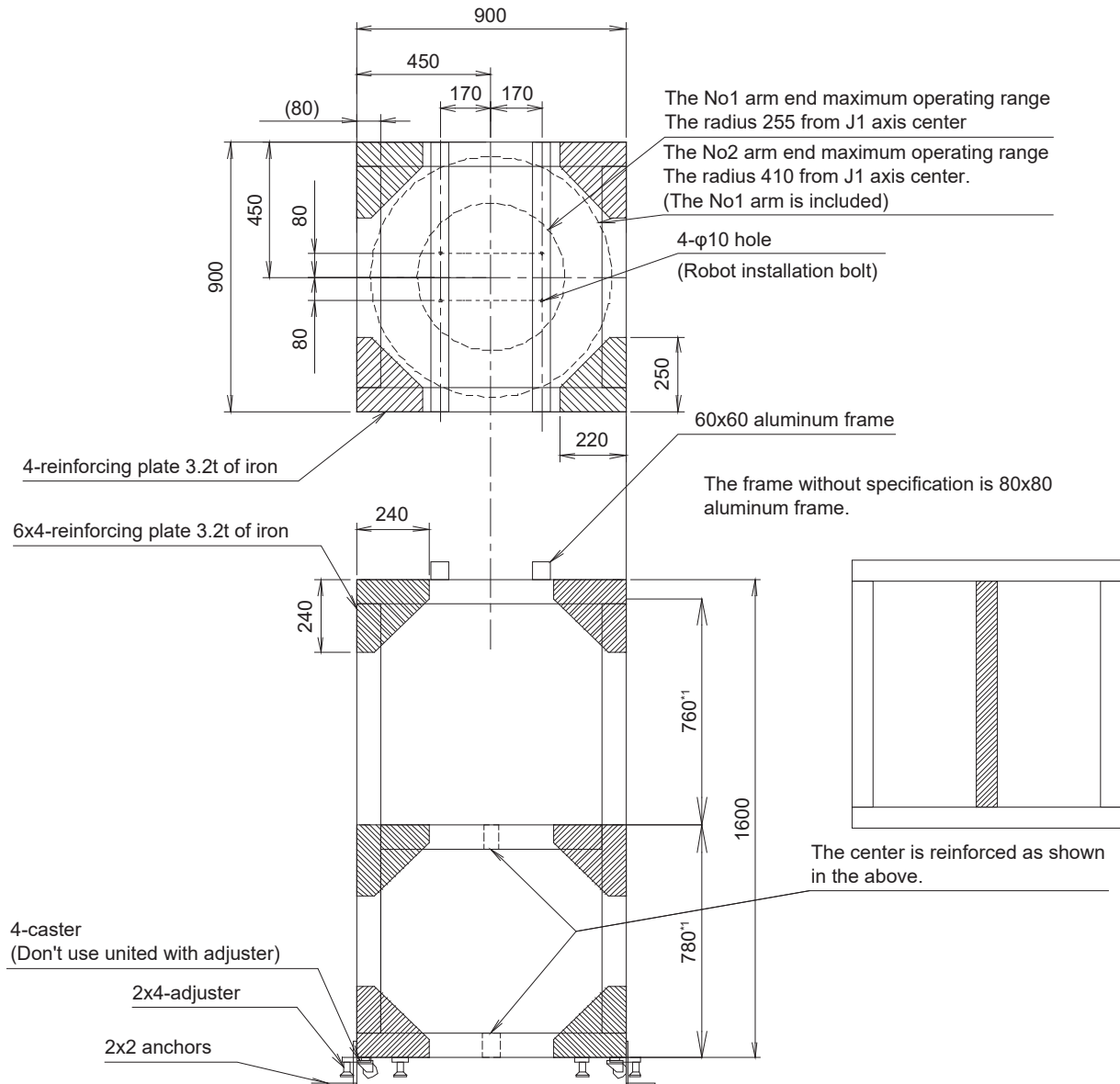

Note 1) The gross weight of this stage is about 200kg.

Note 2) This stage is an example. Please design based on the conditions of the system.

Note 3) Fixing the stage to the floor by anchor etc. If the center of gravity of the stage is in the high position, the stage may fall by movement of the robot.

Fig.: Installation stage (Example of aluminum frame use)

*1 Please arrange operations height based on peripheral equipment, such as the work-piece and the hand.

2.2 Definition of specifications

The accuracy of pose repeatability mentioned in catalogs and in the specification manual is defined as follows.

Pose repeatability

For this robot, the pose repeatability is given in accordance with JIS B 8432 (Pose repeatability). Note that the value is based on 100 measurements (although 30 measurements are required according to JIS).

[Caution]

The specified "pose repeatability" is not guaranteed to be satisfied under the following conditions.

[1] Operation pattern factors

- 1) When an operation that approaches from different directions and orientations are included in relation to the teaching position during repeated operations
- 2) When the speed at teaching and the speed at execution are different

[2] Load fluctuation factor

- 1) When work is present/absent in repeated operations

[3] Disturbance factor during operation

- 1) Even if approaching from the same direction and orientation to the teaching position, when the power is turned OFF or a stop operation is performed halfway

[4] Temperature factors

- 1) When the operating environment temperature changes
- 2) When accuracy is required before and after a warm-up operation

[5] Factors due to differences in accuracy definition

- 1) When accuracy is required between a position set by a numeric value in the robot's internal coordinate system and a position within the actual space
- 2) When accuracy is required between a position generated by the pallet function and a position within the actual space



[6] Positioning movement near the singular point (RH-3FRHR)



Mass capacity

The robot's mass capacity is expressed solely in terms of mass, but even for tools and works of similar mass, eccentric loads will have some restrictions. When designing the tooling or when selecting a robot, consider the following issues.

(1) The tooling should have the value less or equal than the smaller of the allowable inertia found in  Page 48 Basic specifications.

The examples of inertia calculation methods are described in  Page 288 Inertia calculation method.

(2)  Fig.: Position of center of gravity for loads (for loads with comparatively small volume): RH-3FRH series to  Fig.: Position of center of gravity for loads (for loads with comparatively small volume): RH-3FRHR series shows the distribution dimensions for the center of gravity in the case where the volume of the load is relatively small. Use this figure as a reference when designing the tooling.

Please use the robot in the allowable moment of inertia of maximum moment of inertia shown in  Fig.: Position of center of gravity for loads (for loads with comparatively small volume): RH-3FRH series to  Fig.: Position of center of gravity for loads (for loads with comparatively small volume): RH-3FRHR series.

[Caution]

The mass capacity is greatly influenced by the operating speed of the robot and the motion posture. Even if you are within the allowable range mentioned previously, a vibration, an overload or generate an overcurrent alarm could occur. In such cases, please reduce acceleration and deceleration (Accel command) speeds and movement speed (Ovr command). Although the standard value to reduce is 50% for each command, please adjust corresponding to the movement posture. Refer to  CR800 Series Controller INSTRUCTION MANUAL Detailed explanations of functions and operations (BFP-A3478) for details of each command.

Moreover, if hand/workpiece parameters are not set exactly, the similar phenomenon will be easier to occur.

[Caution]

Refer to  Page 67 Relationships Among Mass Capacity, Speed, and Acceleration/Deceleration Speed, and set the values of the mass, magnitude, and distance to the centroid of a tool and a workpiece to parameters.

If parameters are not set exactly, the lifetime of reduction gears, a belt, etc. is affected.

[Caution]

The overhang amount of the load, such as the mass capacity and the allowable moment of inertia defined in this section, are dynamic limit values determined by the capacity of the motor that drives axes or the capacity of the speed reducer. Therefore, it does not guarantee the accuracy on all areas of tooling. Guaranteed accuracy is measured from the center point of the mechanical interface surface. Please note that if the point of operation is kept away from the mechanical interface surface by long and low-rigid tooling, the positioning accuracy may deteriorate or may cause vibration.

Note that the allowable offset value (Z direction) from the lower edge of the shaft to the position of center of gravity is 100 mm.

[Caution]

Even within the allowable range previously mentioned, an overload alarm may be generated if an ascending operation continues at a micro-low speed. In such a case, it is necessary to increase the ascending speed.

[Caution]

This robot will restrict speed automatically by internal controls when the load center-of-gravity position separates from the shaft center. Refer to  Page 67 Relationships Among Mass Capacity, Speed, and Acceleration/Deceleration Speed in detail.

The allowance distance (allowance offset amount) from the center of the shaft to the gravity center of loading weight is shown below

Model	allowance offset amount
RH-3FRH series	less than 100mm
RH-6FRH series	less than 200mm
RH-12FRH series	less than 240mm
RH-20FRH series	less than 320mm
RH-3FRHR series	less than 50mm

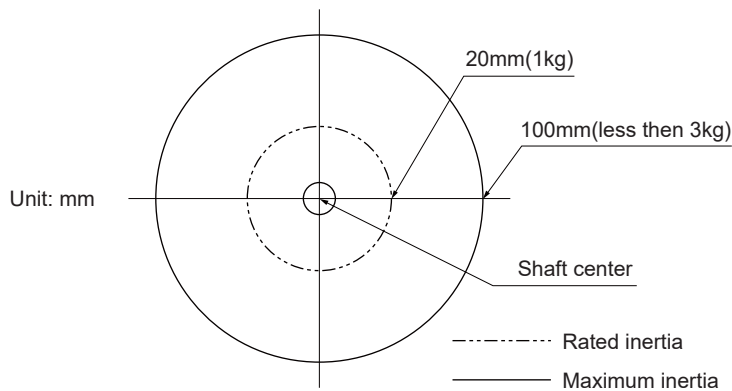

Fig.: Position of center of gravity for loads (for loads with comparatively small volume): RH-3FRH series

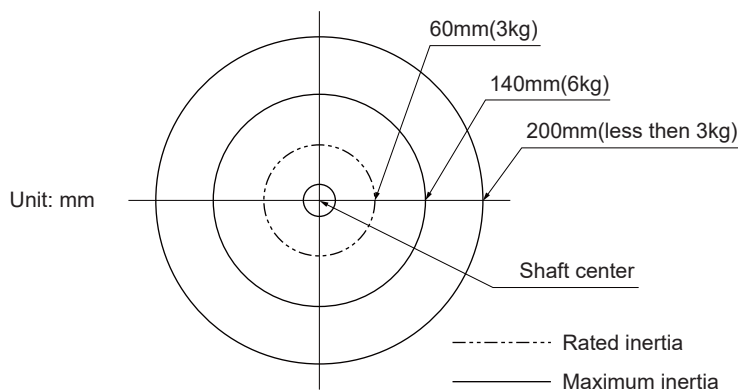

Fig.: Position of center of gravity for loads (for loads with comparatively small volume): RH-6FRH series

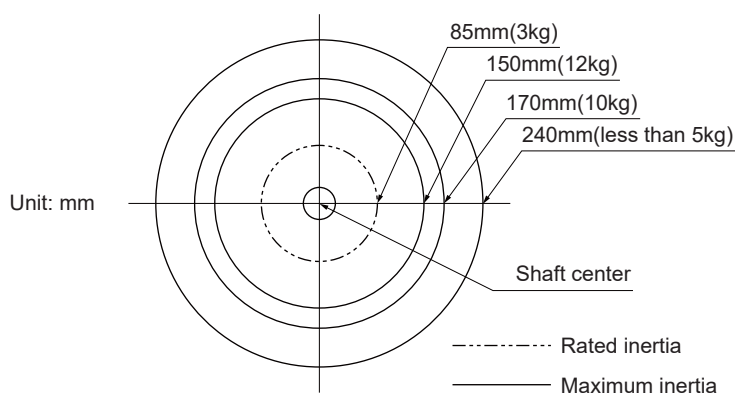

Fig.: Position of center of gravity for loads (for loads with comparatively small volume): RH-12FRH series

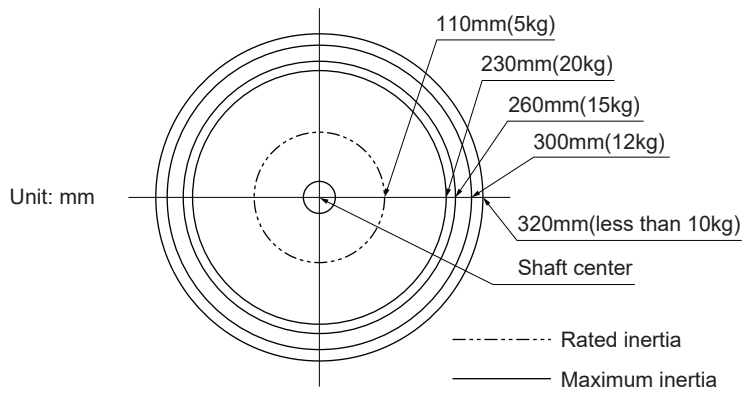

Fig.: Position of center of gravity for loads (for loads with comparatively small volume): RH-20FRH series

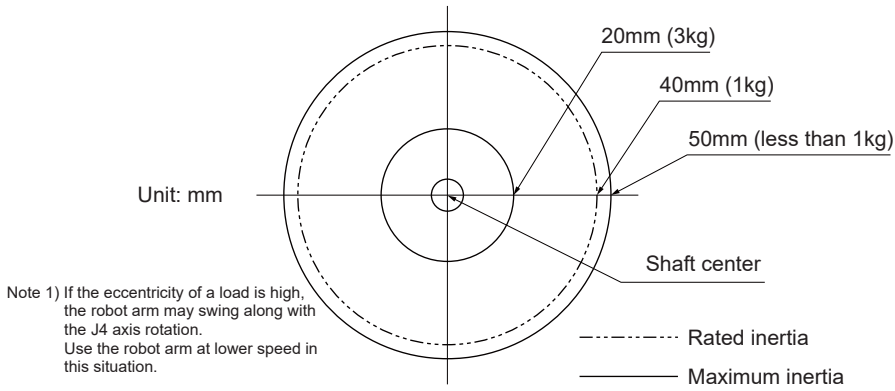

Fig.: Position of center of gravity for loads (for loads with comparatively small volume): RH-3FRHR series

Relationships Among Mass Capacity, Speed, and Acceleration/Deceleration Speed

This robot automatically sets the optimum acceleration and deceleration speeds and maximum speed, according to the load capacity and size that have been set, and operates using these automatically set speeds.

Therefore, it is necessary to set the data of the actually mounted load in advance.

The settings are used in calculation for internal control. Depending on the mounted load or the operation pattern, vibration, excessive error, overload error, etc. may occur. In such cases, use the speed setting (Ovrd) command or the acceleration/deceleration setting (Accel) command in the robot program to decrease the speed or acceleration/deceleration.

If a setting is performed in such a way that it falls below the mounted load, the life span of the mechanism elements used in the robot may be shortened. In the case of a work requiring a high degree of accuracy, set up the load correctly and use the robot by lowering the ratios of the acceleration and deceleration speeds.

Setting Load Capacity and Size (Hand Conditions)

Set up the capacity and size of the hand with the "HNDDAT*" parameter (optimum acceleration/deceleration setting parameter), and set up the capacity and size of the work with the "WRKDAT*" parameter. Numbers 0 to 8 can be used for the asterisk (*) part. Designate the "HNDDAT*" and "WRKDAT*" parameters to be used using the "LoadSet" command in a program.

For more details, refer to [CR800 Series Controller INSTRUCTION MANUAL Detailed explanations of functions and operations \(BFP-A3478\)](#).

It is the same meaning as "LoadSet 0.0" if not using the "LoadSet".

<Factory default settings of RH-3FRH series>

	Hand mass	Size X	Size Y	Size Z	Center-of-gravity position X	Center-of-gravity position Y	Center-of-gravity position Z
	[kg]	[mm]	[mm]	[mm]	[mm]	[mm]	[mm]
HNDDAT0 =	3.00	99.00	99.00	76.00	0.00	0.00	38.00
WRKDAT0 =	0.00	0.00	0.00	0.00	0.00	0.00	0.00

<Factory default settings of RH-6FRH series>

	Hand mass	Size X	Size Y	Size Z	Center-of-gravity position X	Center-of-gravity position Y	Center-of-gravity position Z
	[kg]	[mm]	[mm]	[mm]	[mm]	[mm]	[mm]
HNDDAT0 =	6.00	99.00	99.00	76.00	0.00	0.00	38.00
WRKDAT0 =	0.00	0.00	0.00	0.00	0.00	0.00	0.00

<Factory default settings of RH-12FRH series>

	Hand mass	Size X	Size Y	Size Z	Center-of-gravity position X	Center-of-gravity position Y	Center-of-gravity position Z
	[kg]	[mm]	[mm]	[mm]	[mm]	[mm]	[mm]
HNDDAT0 =	12.00	165.00	165.00	64.00	0.00	0.00	16.00
WRKDAT0 =	0.00	0.00	0.00	0.00	0.00	0.00	0.00

<Factory default settings of RH-20FRH series>

	Hand mass	Size X	Size Y	Size Z	Center-of-gravity position X	Center-of-gravity position Y	Center-of-gravity position Z
	[kg]	[mm]	[mm]	[mm]	[mm]	[mm]	[mm]
HNDDAT0 =	20.00	165.00	165.00	109.00	0.00	0.00	37.00
WRKDAT0 =	0.00	0.00	0.00	0.00	0.00	0.00	0.00

<Factory default settings of RH-3FRHR series>

	Hand mass	Size X	Size Y	Size Z	Center-of-gravity position X	Center-of-gravity position Y	Center-of-gravity position Z
	[kg]	[mm]	[mm]	[mm]	[mm]	[mm]	[mm]
HNDDAT0 =	3.00	76.00	76.00	58.00	0.00	0.00	24.00
WRKDAT0 =	0.00	0.00	0.00	0.00	0.00	0.00	0.00

Note) The position of the center of gravity is located at the center of the surface at the bottom of the shaft. Set the X, Y and Z center of gravity positions for the tool coordinate directions (the Z center of gravity position will be a plus for downward directions).

Vibrations at the Tip of the Arm during Low-Speed Operation of the Robot

Vibrations at the tip of the arm may increase substantially during the low-speed operation of the robot, depending on the combination of robot operation, hand mass and hand inertia. This problem occurs when the vibration count specific to the robot arm and the vibration count of the arm driving force are coming close to each other. These vibrations at the tip of the arm can be reduced by taking the following measures:

- 1) Change the robot's operating speed by using the Ovr command.
- 2) Change and move the teaching points of the robot.
- 3) Change the hand mass and hand inertia.

Vibration of shaft (J3 axis) position and arm end

Vibrations at the tip of the arm may increase substantially during operation under the shaft position near the low end or the high end of the robot, depending on the combination of hand mass and hand inertia. This problem occurs according to that inertia, because the distance from the shaft support section to the shaft end becomes long. When this vibration affects the robot's operations, please change operating speed etc. like the above  Page 68 Vibrations at the Tip of the Arm during Low-Speed Operation of the Robot.

Relationship Between Mass Capacity and Speed

A function to optimize the maximum speed of each axis according to the setting value of the load capacity will be activated (Refer to  Fig.: Automatic compensation of speed).

However, this function does not work with the following load mass setting value or smaller.

Model	Load mass setting
RH-3FRH series, RH-3FRHR series	1kg
RH-6FRH/12FRH series	3kg
RH-20FRH series	5kg

When the load mass is set to a value greater than the above setting, the maximum speed is compensated according to the load mass.

[CAUTION]

Depending on the operation pattern, the speed and/or acceleration/deceleration at the front edge may not be parallel with the speed and the rate of change of acceleration/deceleration specified in a program.

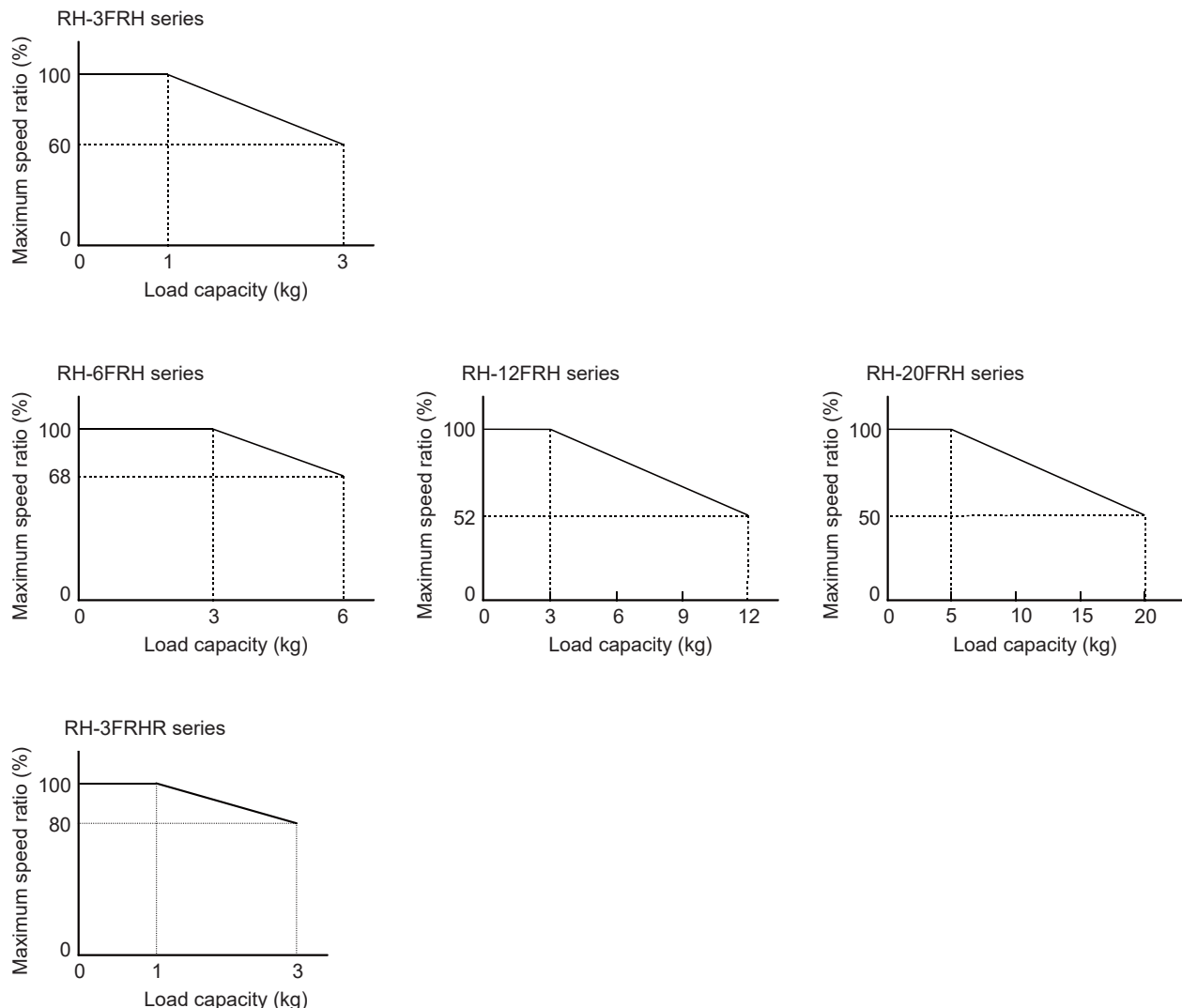

Fig.: Automatic compensation of speed

Relationship Between Height of Shaft (J3 Axis) and Acceleration/Deceleration Speed

A function to optimize the acceleration/deceleration speed according to the height of the shaft (Refer to Fig.: Area in which acceleration/deceleration speed is compensated, Fig.: Automatic compensation of acceleration/deceleration speed) will be activated. This function is invalid if the shaft (axis J3) operates at a position above P3 in Fig.: Area in which acceleration/deceleration speed is compensated. Acceleration/deceleration is compensated for at a position below P3 in Fig.: Area in which acceleration/deceleration speed is compensated if the position of the center of gravity of the load is located at the front edge of the shaft.

This function contains both a standard acceleration and deceleration pattern and a high acceleration and deceleration pattern, both of which can be selected in the parameters. The original settings are set to the standard acceleration and deceleration pattern, which enables operation while keeping vibration at the shaft tip (including residual vibration) to a minimum. Users are also able to select the high acceleration and deceleration pattern and operate the robot at high speed. When doing so, users should make sure that additional vibration will not have a negative impact on work carried out by the robot. Where necessary the pattern should be changed, allowing the robot to be used in the most effective way.

The relevant parameter names and their set values are shown below. For more details about parameters and how to change them, please refer to ICR800 Series Controller INSTRUCTION MANUAL Detailed explanations of functions and operations (BFP-A3478).

●Parameter name

MAPMODE (acceleration and deceleration optimization pattern selected)

●Set value and function

0: Standard acceleration and deceleration pattern (original setting)

1: High acceleration and deceleration pattern

Note 1) The RH-3FRH series and RH-3FRHR series have standard acceleration-and-deceleration mode only.

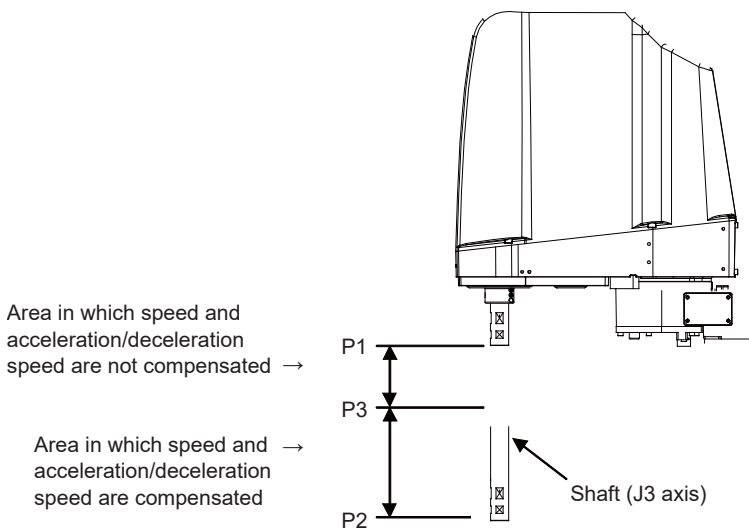

Fig.: Area in which acceleration/deceleration speed is compensated

Table: Area in which acceleration/deceleration speed is compensated

Model	J3 axis stroke (mm)			Compensation area (P2 to P3)
	Stroke length	P1(Upper end)	P2(Lower end)	
RH-3FRH series	120	340	220	220~310
	150	370	220	220~310
RH-6FRH series *1	340	333	-7	-7 to 133
RH-12FRH/20FRH series	350	340	-10	-10 to 240
	450	340	-110	-110 to 155
RH-3FRHR series	150	-583	-733	-733 to -643

*1 When stroke of J3 axis is 200mm this function is not operate.

RH-3FRH series

J3 axis (Z) stroke 120mm/150mm
(Standard Acceleration/deceleration speed)

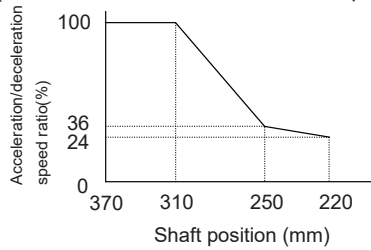

RH-6FRH series

J3 axis (Z) stroke 340mm
(Standard Acceleration/deceleration speed)

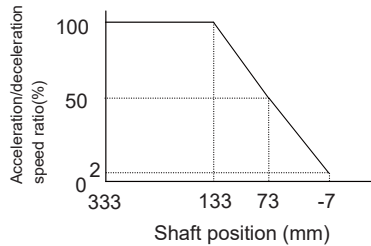

J3 axis (Z) stroke 340mm
(High acceleration and deceleration rate)

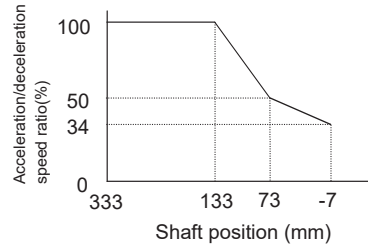

RH-12FRH series

J3 axis (Z) stroke 350/450mm
(Standard Acceleration/deceleration speed)

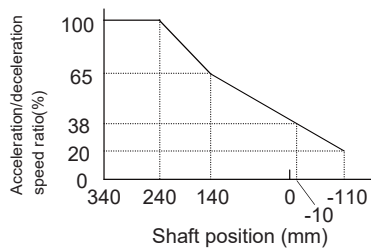

J3 axis (Z) stroke 350/450mm
(High Acceleration/deceleration speed)

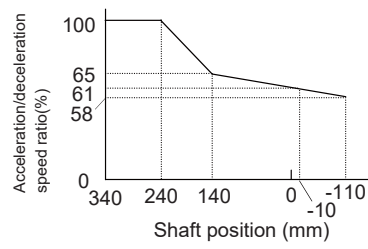

RH-20FRH series

J3 axis (Z) stroke 350/450mm
(Standard Acceleration/deceleration speed)

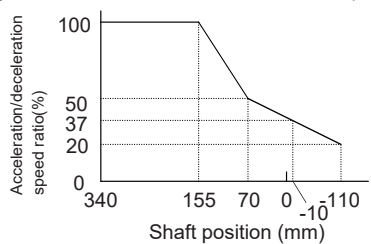

J3 axis (Z) stroke 350/450mm
(High Acceleration/deceleration speed)

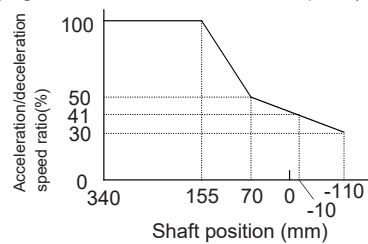

RH-3FRHR series

J3 axis (Z) stroke: 150mm
(Standard Acceleration/deceleration speed)

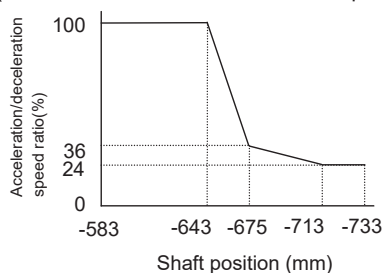

Note 1) The high acceleration-and-deceleration pattern of the type without illustration of the high acceleration-and-deceleration pattern is the same as the standard acceleration-and-deceleration pattern.

Fig.: Automatic compensation of acceleration/deceleration speed

Relation between offset length and the maximum speed

A function to optimize the maximum speed of each axis according to the offset length will be activated. (Refer to Fig.: Relationship of the offset length and maximum velocity)

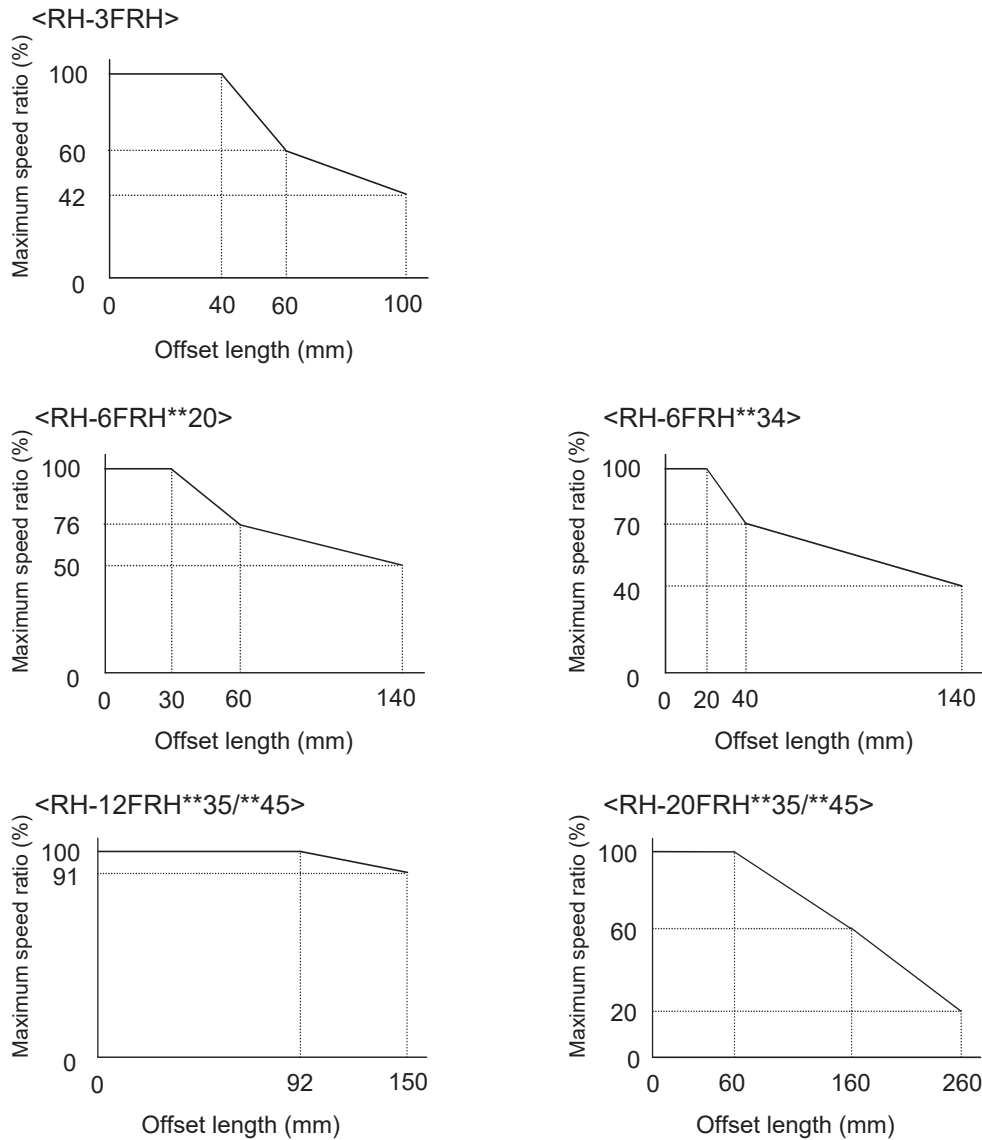

Fig.: Relationship of the offset length and maximum velocity

[Supplementary explanation 1]: The setting which shortens execution time

The execution time can be improved by using the following methods.

- 1) Perform continuous path operation using the Cnt command.
- 2) Control the optimum acceleration/deceleration using the Oadl command.
- 3) Control the optimum speed using the Spd command.
- 4) Setting a larger value in the optimum acceleration/deceleration adjustment rate parameter: JADL. (Maximum 100)

The moving time can be shortened by setting a larger value in the optimum acceleration/deceleration adjustment rate parameter (JADL). In this robot, the acceleration/deceleration speed is initialized to allow continuous moving with a short wait time (setting of B in the Fig.: Relationship between Acceleration/deceleration Speed and Tact Time (Conceptual Drawing)).

This setting is suited for continuous operations that have a short tact time, such as palletizing work.

Conversely, if quick moves (short moving time) are required, such as L/UL work on machined parts, the acceleration/deceleration speed can be increased by initial setting (setting of A in the Fig.: Relationship between Acceleration/deceleration Speed and Tact Time (Conceptual Drawing)).

However, please note that some setting values of acceleration/deceleration speed tend to cause overload and overheat errors. In such a case, extend the wait time, reduce the acceleration/deceleration speed, or decrease the moving speed.

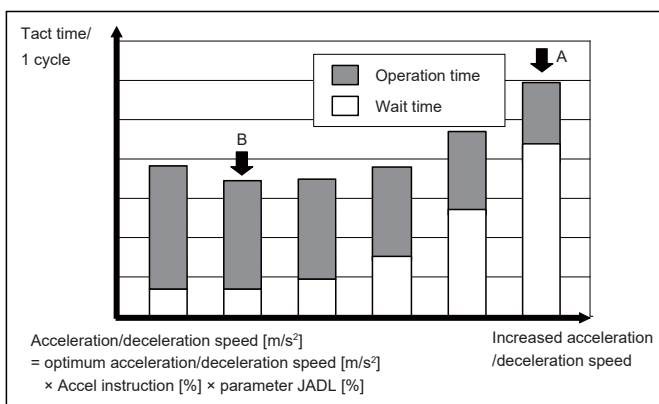

Fig.: Relationship between Acceleration/deceleration Speed and Tact Time (Conceptual Drawing)

- 5) Move without changing the posture. (RH-3FRHR series)

The robot's moving time is influenced not only by the size of moving distance but by posture change.

The example is shown in Fig.: Moving time by posture change (Conceptual Drawing). When moving changing the posture (left side of the figure), the movement distance is shorter, but moving time may become long conversely. Conversely, When moving without changing the posture, moving time may become shorter (right side of the figure).

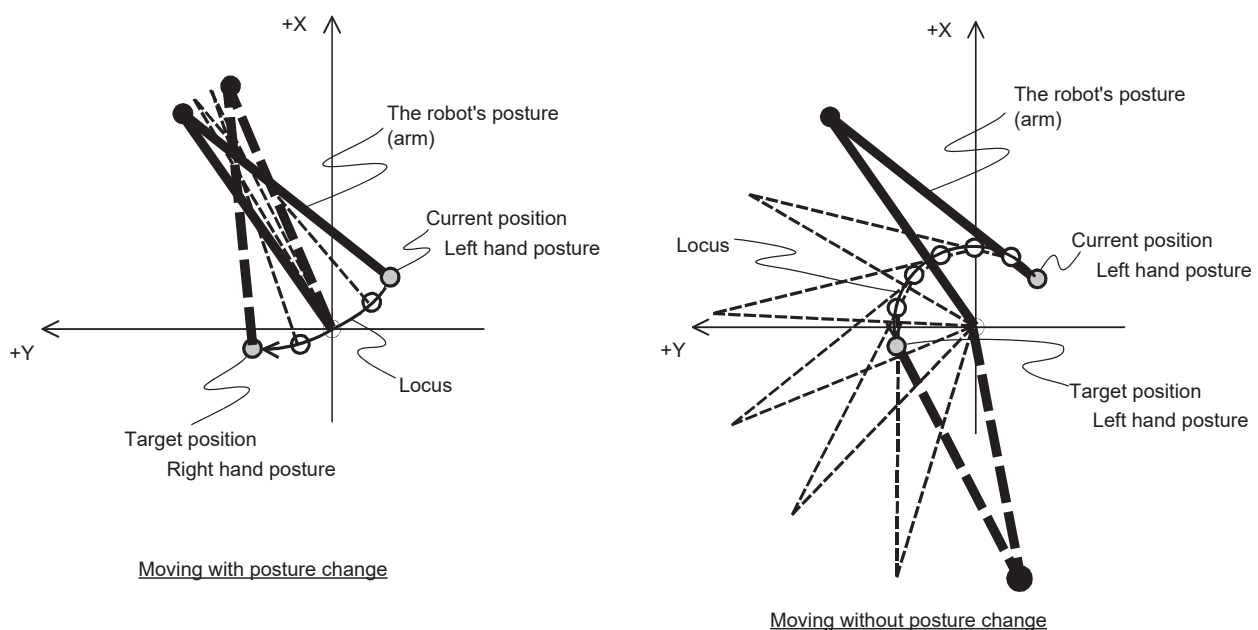

Fig.: Moving time by posture change (Conceptual Drawing)

Time to reach the position repeatability

When using this robot, the time to reach the position repeatability may be prolonged due to the effect of residual vibration at the time of stopping. If this happens, take the following measures:

- 1) Change the operation position of the Z axis to the location near the top as much as possible.
- 2) Increase the operation speed prior to stopping.
- 3) When positioning the work near the bottom edge of the Z axis, if no effectiveness is achieved in step 2) above, perform operation <1> (robot path: O → A → C). In the case of operation <2> (robot path: O → B → C), residual vibration may occur. (Refer to Fig.: Recommended path when positioning at the bottom edge of the Z axis.)

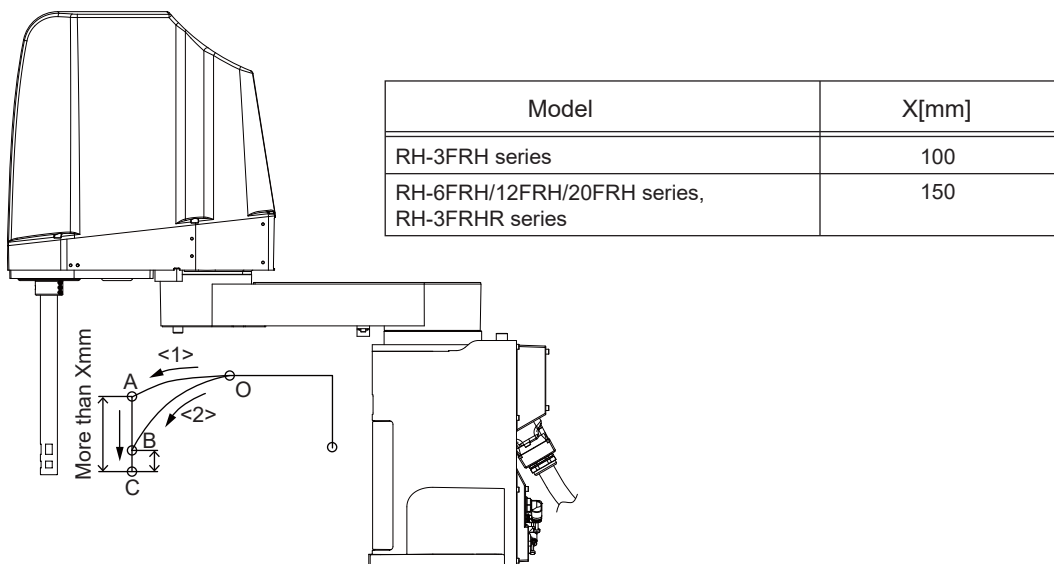
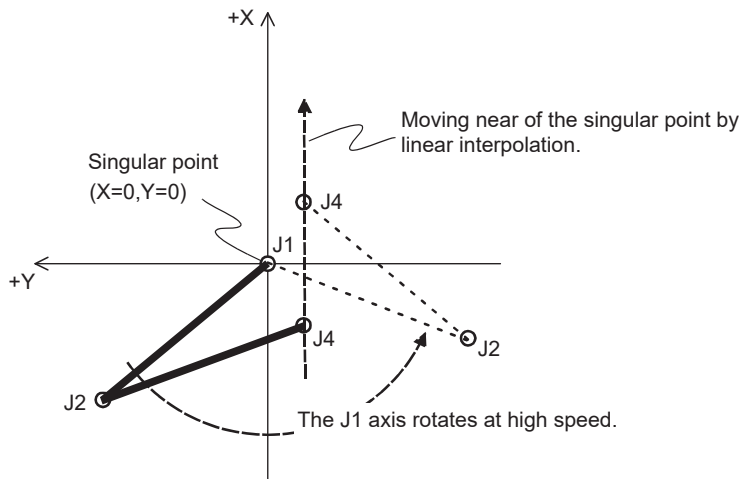

Fig.: Recommended path when positioning at the bottom edge of the Z axis

About moving speed at singular point and near singular point. (RH-3FRHR series)

The robot of our company has memorized the teaching position and calculates of linear interpolation movement using the position data in the XYZ coordinate system. Even if it is the same position data, the robot can take two or more postures. For example, if X coordinate value is "0" and Y coordinate value is also "0", the rotation angle of J1 axis is not decided uniquely. This position is called singular point, and positioning or passing with XYZ JOG and linear interpolation will not be performed. And, even though based on the specified speed, when moving near singular point with linear interpolation, the error occurs, because the J1 axis must rotate at the big speed. ("a)" of Fig.: The singular point and the speed regulation near the singular point). However, in RH-3FRHR series, speed was lowered automatically and it has the function which can be passed without the error.

In addition, this function can be changed valid/invalid by setting of parameter:SPDOPT, and SpdOpt command. Refer to **CR800 Series Controller INSTRUCTION MANUAL Detailed explanations of functions and operations (BFP-A3478)**. And, the area in R2 shown in "b)" of Fig.: The singular point, and positioning and passage with linear interpolation movement cannot be performed. In joint interpolation movement, positioning and passage are possible. It is in valid condition at shipping.



a) The singular point and the movement near the singular point

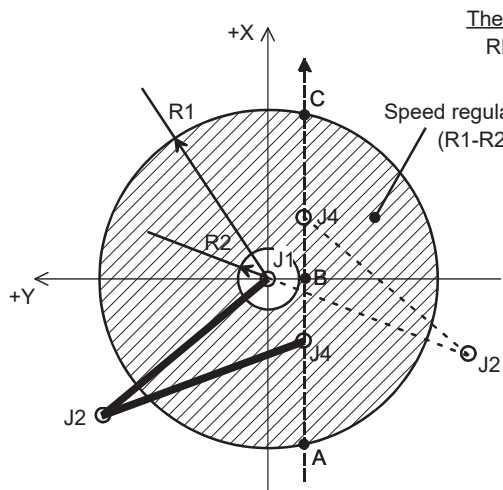

b) Speed regulation area

The range of the speed regulation area
 RH-3FRHR series
 R1=240.0mm, R2=1.0mm

- A: Starts the slowdown if robot goes into the speed regulation area.
- B: Accelerates slowly towards going out.
- C: If robot goes out completely from speed regulation area, it returns to specification speed.

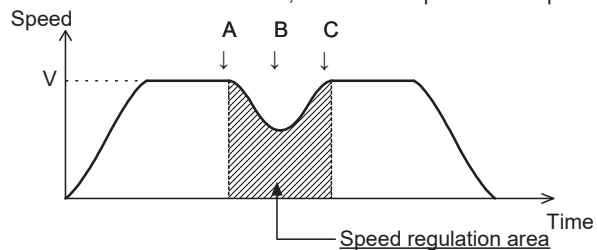

c) Speed change in the speed regulation area

Fig.: The singular point and the speed regulation near the singular point

Collision detection

This series have the "collision detection function" which detects the abnormalities by the collision of the robot arm, and the initial setting has set this function as the enable to suppress damage to the minimum.

Although the enable/disable of this function can be changed by parameter: COL and command: ColChk, you should use in valid condition of this function for protection of the robot and of the peripheral equipment.

The abnormalities are detected by the robot's kinetics model, presuming torque necessary for movement at any time.

Therefore, the setting parameter (HNDDAT*, WRKDAT*) of the hand and the work piece conditions should be right. And, it may be detected as the collision in movement as speed and motor torque are changed rapidly. (for example, the movement near the place of the origin by linear interpolation, the reversal movement, the cold condition, the operation after long term stoppage)

In such a case, by adjusting the value of the setting parameter (COLLVL, COLLVLJG) of the collision detection level according to actual use environment, the sensitivity of collision detection can be optimized and the damage risk can be reduced further. And, in the operation after the low temperature or long term stoppage, please operate by accustoming at low speed (warm-up), or use the warm-up operation mode.

Refer to  CR800 Series Controller INSTRUCTION MANUAL Detailed explanations of functions and operations (BFP-A3478) for details of related

parameter.

Table: Factory-shipments condition

	JOG operation	Automatic
RH-3FRH/6FRH/12FRH/20FRH series	Valid	Invalid
RH-3FHR series	Valid	Valid

Protection specifications

Types of protection specifications



The robot arm has protection specifications that comply with the IEC Standards. The protection specifications and applicable fields are shown in  Table: Protection specifications and applicable fields.

Table: Protection specifications and applicable fields

Type	Protection specifications (IEC Standards value)	Classification	Applicable field	Remarks
RH-3FRHxx15 RH-6FRHxx20/xx34 RH-12FRHxx35/xx45 RH-20FRHxx35/xx45 RH-3FRHR3515	IP20	General-purpose environment specifications	General assembly Slightly dusty environment	
RH-6FRHxx20M/xx34M RH-12FRHxx35M/xx45M RH-20FRHxx35M/xx45M	IP65 (Direct jet flow to the bellows section is not included.)	Oil mist specifications	Machine tool (cutting) Machine shop with heavy oil mist Dusty work shop	Note that if the cutting machine is using abrasive materials, the robot's life will be shortened.
RH-3FRHR3512W	IP65 (Direct jet flow to the bellows section is not included.)	Waterproof specifications	Food processing (handling) The work shops which requires washing of a robot arm.	

CAUTION

Use the controller protection box to protect the controller from the environment when the controller will be used in the environment such as the oil mist shown in the  Table: Protection specifications and applicable fields.

The IEC IP symbols define the degree of protection against solids and fluids, and do not indicate a protective structure against the entry of oil.

The IEC standard is described by the following "Information", and the corrosion of the rust etc. may occur to the robot with the liquids.

[Information]

•The IEC IP20

[Degree of protection against solids]

It indicates the protective structure that prevents an iron ball $12^{+0.05}_0$ mm diameter, which is being pressed with the power of 3.1 kg±10%, from going through the opening in the outer sheath of the supplied equipment.

[Degree of protection against water]

No protection against water ingress.

•The IEC IP65

[Degree of protection against solids]

Protective structure designed for complete protection against dust ingress.

[Degree of protection against water]

Protection against water infiltration as specified in IP65 indicates a protective structure that is not harmfully affected when 12.5±5% liters of water is supplied from a test device at a position approx. 3m away in various directions and a water pressure of 30kPa at the nozzle section. The water is filled one minute per 1m² of test device surface area for a total of three minutes.

About the use with the bad environment

The protection specifications robot has protection methods that conform to IEC's IP65 standards. (Direct jet flow to the bellows section is not included.)

It has protection structure designed to prevent harmful effects caused by splashing water coming from various directions, as the robot is operating. (Direct jet flow to the bellows section is not included.)

Recommended usage conditions

Usage conditions are shown below.



- 1) The robot is designed for use in combination with machining device.
- 2) Robot's protection performance can be improved by pressurizing its interior. If you use a robot in an environment where oil mist is present, it is recommended that the interior of the robot be pressurized to ensure its reliability over a long period of time. Use the provided $\phi 8$ joint (AIR PURGE) to supply dry air for pressurizing ( Fig.: Wiring and piping for hand (Floor installation type),  Fig.: Wiring and piping for hand (Ceiling mounted type)). The $\phi 8$ joint (AIR PURGE) can be found at the base rear part of the robot arm. Recommended air purge equipment is shown in  Table: Recommended air purge equipment.

Table: Specification of the dry air for pressurization

Item	Dew point	Pressure
Specification	The atmospheric pressure dew point is -20 degree or less.	0 to 3kPa

Table: Recommended air purge equipment

Item	Part name	Required number	Manufacture
Membrane air dryer	IDG3M-02C-S	1	SMC
Precision regulator	IR1000-01G	1	SMC
Spacer (Connection part)	Y20	1	SMC

3) We have confirmed that the robot arm meets the protection specifications by testing it using our specified cutting oil. However, the parts of the controller may be damaged by the cutting oil. When using the controller in an oil mist environment, always use the controller protection box. Our warranty does not cover damages or failure resulting from the robot being operated in any environment where other cutting oils than those listed in the table are used (except cutting oils with respect to which the robot's compatibility with the protection specification is verified through our operability evaluation) or where the robot body may be directly splashed with water, oil or dust in quantities larger than stated in the protection specification.

4) Take measures so that the robot will not be exposed to water, oil and/or chips for a long period of time.

5) The packing gets deteriorated with the passage of time and must be replaced as required.  Table: Packing replacement guideline provides guidelines for replacing the packing. Failure to replace the packing may cause water or oil to get into the robot, resulting in malfunction of the robot. For the information on the packing to be replaced and the liquid gasket to be used, contact the dealer.

Table: Packing replacement guideline

Environment	Whether or not robot is pressurized	When packing must be replaced
General environment	Not pressurized *1	When signs of cracking or peeling are noted in the packing.
Clean room	Not pressurized *1	
Oil mist	Pressurized	When removing and installing the cover.
	Not pressurized	

*1 The pressurization inside the robot arm is unnecessary in general environment and clean room environment.

Also, entrained water droplets lead to the formation of rust on the robot, but would not usually affect the robot's ability to operate normally.

The warranty is invalid for any faults that occur when the robot is used under the following conditions.

Also, if the cover and/or other parts are damaged by interferences caused by the peripheral devices and the robot, the protection specification (seal performance, etc.) may be degraded. Therefore, please pay extra attention when handling the robot.

Refer to  Page 283 Working environment.

- 1) In surroundings that generate inflammable gases or corrosive gasses.
- 2) Atmosphere of the mist containing polish liquid etc.
- 3) Atmosphere in which the water, the oil, and the dust exceeding protection specification fall on the robot arm directly.
- 4) Pressurization by the dry air exceeding the specification of  Table: Specification of the dry air for pressurization.

Clean specifications

Types of clean specifications

The robot arm with clean specification is made by order. Please check the delivery schedule.

Table: Clean specifications

Type	Degree of cleanliness	Internal suction	Remarks
RH-3FRHxx12C RH-6FRHxx20C/xx34C RH-12FRHxx35C/xx45C RH-20FRHxx35C/xx45C	ISO class 3 *1	Suck the inside of robot arm with vacuum pump. (prepared by customer) Use it in the clean room with the down flow (flow velocity 0.3 m/s above).	The use of a vacuum generating valve is recommended.
RH-3FRHR3512C	ISO class 5 *2		

*1 The conditions necessary to guarantee cleanliness are as follows: clean room down flow 0.3 m/s or greater, robot internal suction of RH-3FRH/6FRH series: 30-50L/min, RH-12FRH/20FRH series: 60-140L/min, and installation of an exhaust duct at the rear of the robot's main base. A $\varnothing 8$ joint is prepared at the rear of the base for suction.

*2 The conditions necessary to guarantee cleanliness are as follows: clean room down flow 0.3 m/s or greater, robot internal suction of 3-5L/min. A $\varnothing 8$ joint is prepared at the rear of the base for suction.

■Precautions for use

1) A $\phi 8$ VACUUM coupling is provided in the base section of the robot arm for vacuum inside the robot arm. (Refer to Fig.: Wiring and piping for hand (Floor installation type) or Fig.: Wiring and piping for hand (Ceiling mounted type))
When using the robot, connect this coupling with the vacuum generating valve (Refer to Table: Specifications of vacuum generation valve (Confirmed in our company) and vacuum pump (furnished by the customer).

2) To suck in the robot arm, use the vacuum generator of the specification shown in following a) and b).

a) When using the vacuum generator

Table: Specifications of vacuum generation valve (Confirmed in our company)

Type	Maker	Air pressure *1	Quantity
MEDT 14	KOGANEI CORPORATION	Vacuum rate: 90.0 L/min(ANR)	RH-3FRH/6FRH series: 1 RH-12FRH/20FRH series: 2
ME05	KOGANEI CORPORATION	Vacuum rate: 6.3 L/min(ANR)	RH-3FRHR series: 1

*1 It is the vacuum pump maker's written specification.

b) When using the vacuum pump

Assure the vacuum flow rate of RH-3FRH/6FRH series: 30-50L/min, RH-12FRH/20FRH series: 60-140L/min, and RH-3FRHR series: 3-5L/min. RH-12FRH/20FRH has two VACUUM couplings. Please be sure to suck in using both of couplings.

And, secure the exhaust course from the pump not to affect the power supply and the cleanliness for the vacuum pumps.

3) The ventilation duct is attached to the robot arm rear (refer to Fig.: Installation of Ventilation Duct). As the Z axis moves up and down the volume of the bellows varies, and air is sucked in and released out of the robot's ventilation duct opening. Be sure to locate the ventilation duct's opening in a position that will not affect the robot's cleanliness.

Furthermore, whilst it is only a small amount, internal suction results in external air flows into the robot through the ventilation duct's opening, and therefore the following two points should be considered when deciding where to locate the ventilation duct's opening.

- The opening should be facing downwards
- The opening should not be located in the vicinity of dust/dirt or liquids, etc.

(Recommended cleanliness of surrounding area: less than ISO class 5)

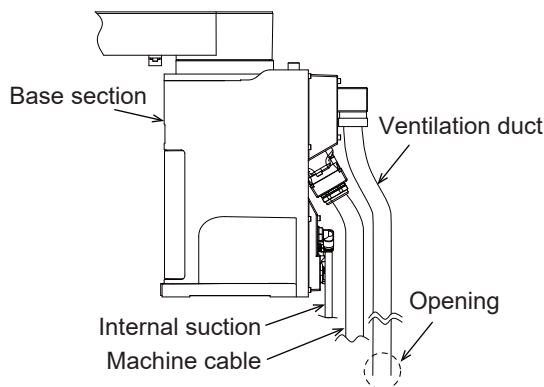

Fig.: Installation of Ventilation Duct

4) When using the optional electromagnetic valve set, we recommend using the primary piping's spare piping ($\phi 6$ air hose) to release the exhaust fumes.

Please take care as leaking exhaust fumes inside the robot may have an impact on the robot's cleanliness.

2.3 Names of each part of the robot

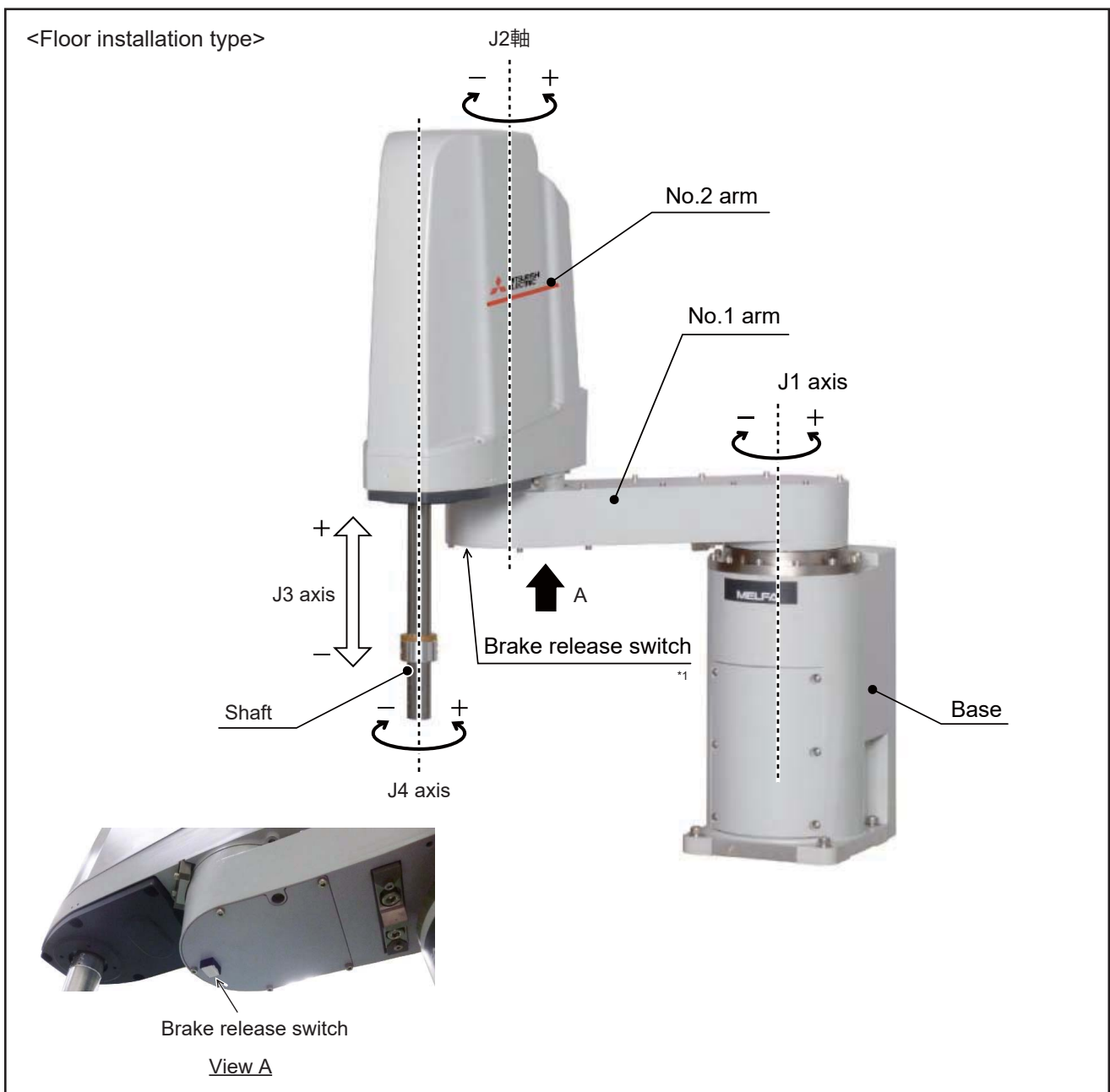

Fig.: Names of each part of the robot (Floor installation type)

*1 The operation method of the brake release switch.

The brake of the J3 axis can be released by operating this switch.

When releasing the brake, please provide support or take other precaution to prevent the falling of J3 axis.

CAUTION

When releasing the brake the J3 axis will drop. To ensure safety, take appropriate measures such as supporting the axis to avoid the free fall.

- (1) Provide support or take other precaution to prevent the falling of J3 axis.
- (2) Push the brake release switch. The brake is released while the switch is pressed in.

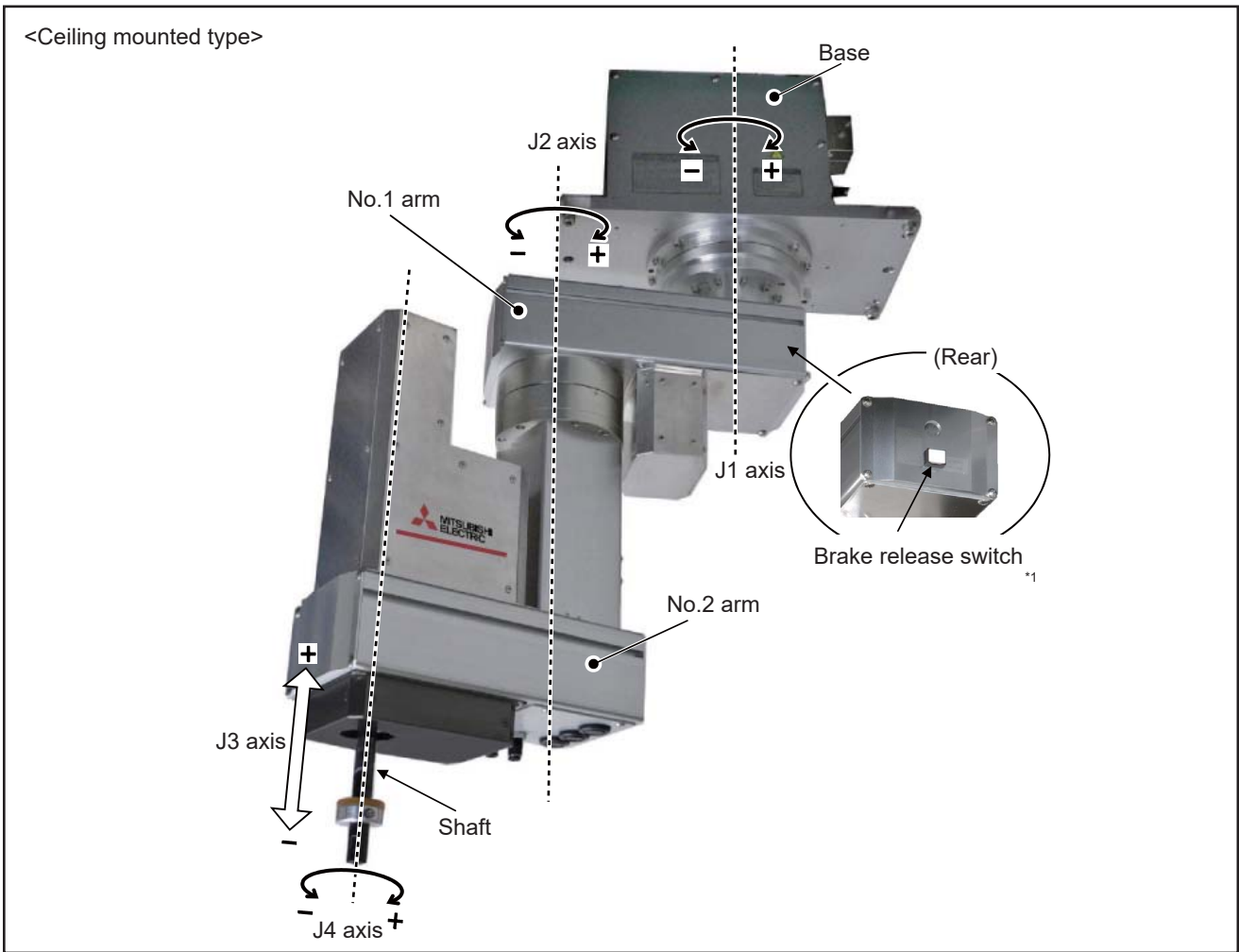

Fig.: Names of each part of the robot (Ceiling mounted type)

*1 The operation method of the brake release switch.
 The brake of the J3 axis can be released by operating this switch.
 When releasing the brake, please provide support or take other recaution to prevent the falling of J3 axis.

⚠ CAUTION

When releasing the brake the J3 axis will drop. To ensure safety, take appropriate measures such as supporting the axis to avoid the free fall.

- (1) Provide support or take other recaution to prevent the falling of J3 axis.
- (2) Push the brake release switch. The brake is released while the switch is pressed in.

2.4 Outside dimensions · Operating range diagram

Outside dimensions · Operating range diagram (RH-3FRH series)

Standard Specification

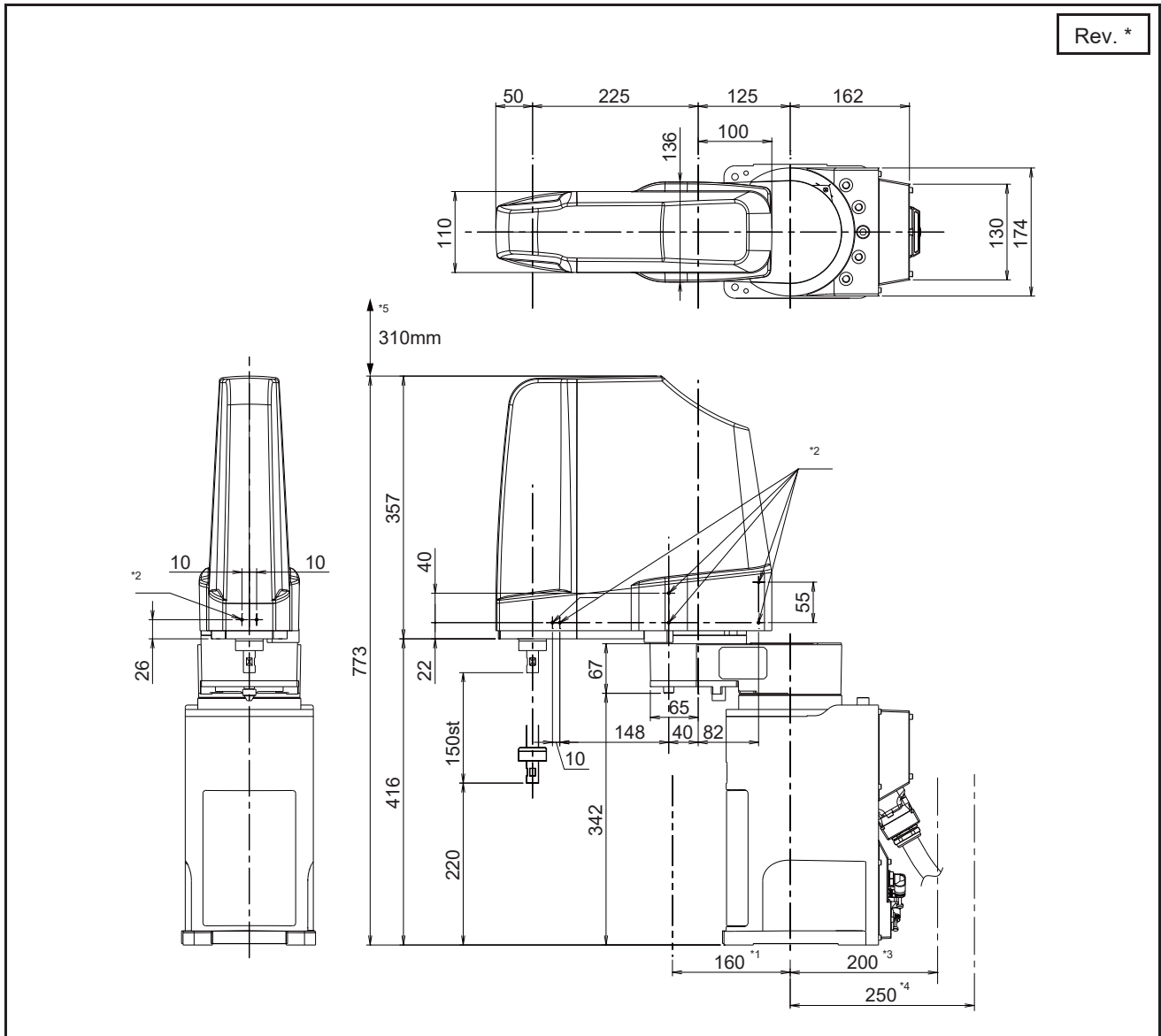

Fig.: Outside dimensions of RH-3FRH3515

*1 Indicates the space necessary to replace the battery.

*2 Indicates the screw holes (M4 / depth 6mm) for fixing user wiring/piping. (Six places on both sides of No.2 arm, two places on the front surface.)

*3 The distance to the minimum bendable radius of the machine cable.

*4 Indicates the space required to connect the machine cable.

*5 Space required to install/remove the cover.

Note) Refer to Fig.: Mechanical interface and Installation surface (RH-3FRH series) for the mechanical interface section and installation base section dimensions

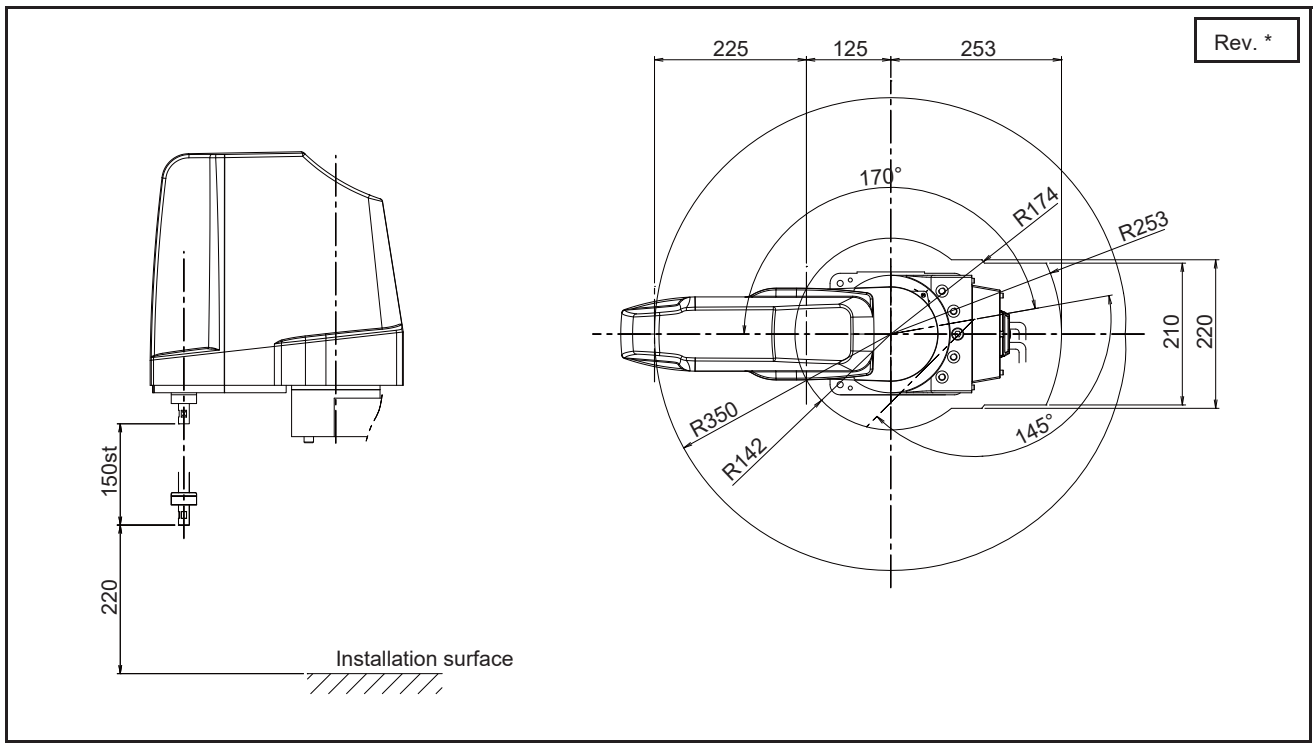

Fig.: Operating range diagram of RH-3FRH3515

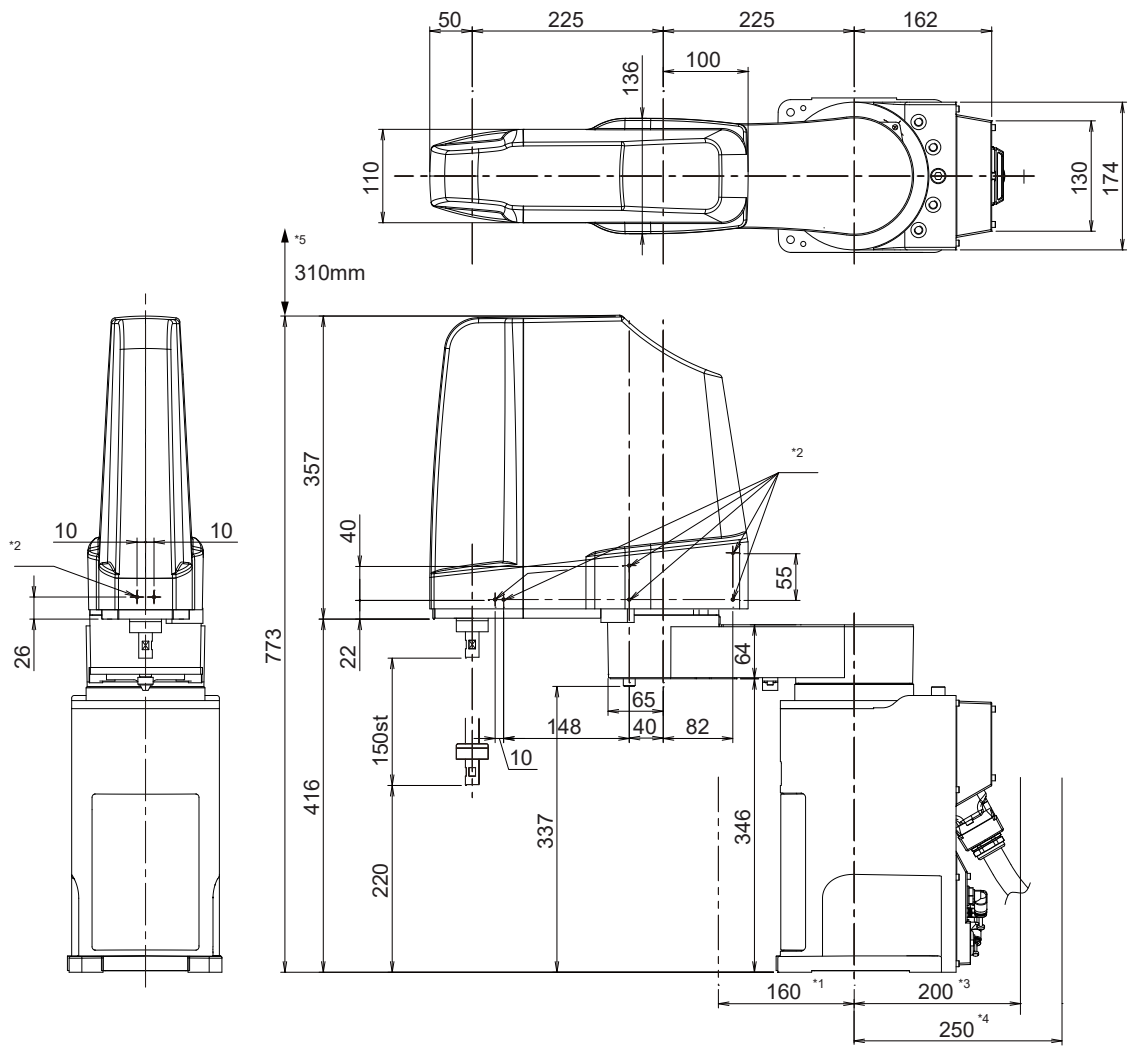

Fig.: Outside dimensions of RH-3FRH4515

*1 Indicates the space necessary to replace the battery.

*2 Indicates the screw holes (M4 / depth 6mm) for fixing user wiring/piping. (Six places on both sides of No.2 arm, two places on the front surface.)

*3 The distance to the minimum bendable radius of the machine cable.

*4 Indicates the space required to connect the machine cable.

*5 Space required to install/remove the cover.

Note) Refer to  Fig.: Mechanical interface and Installation surface (RH-3FRH series) for the mechanical interface section and installation base section dimensions.

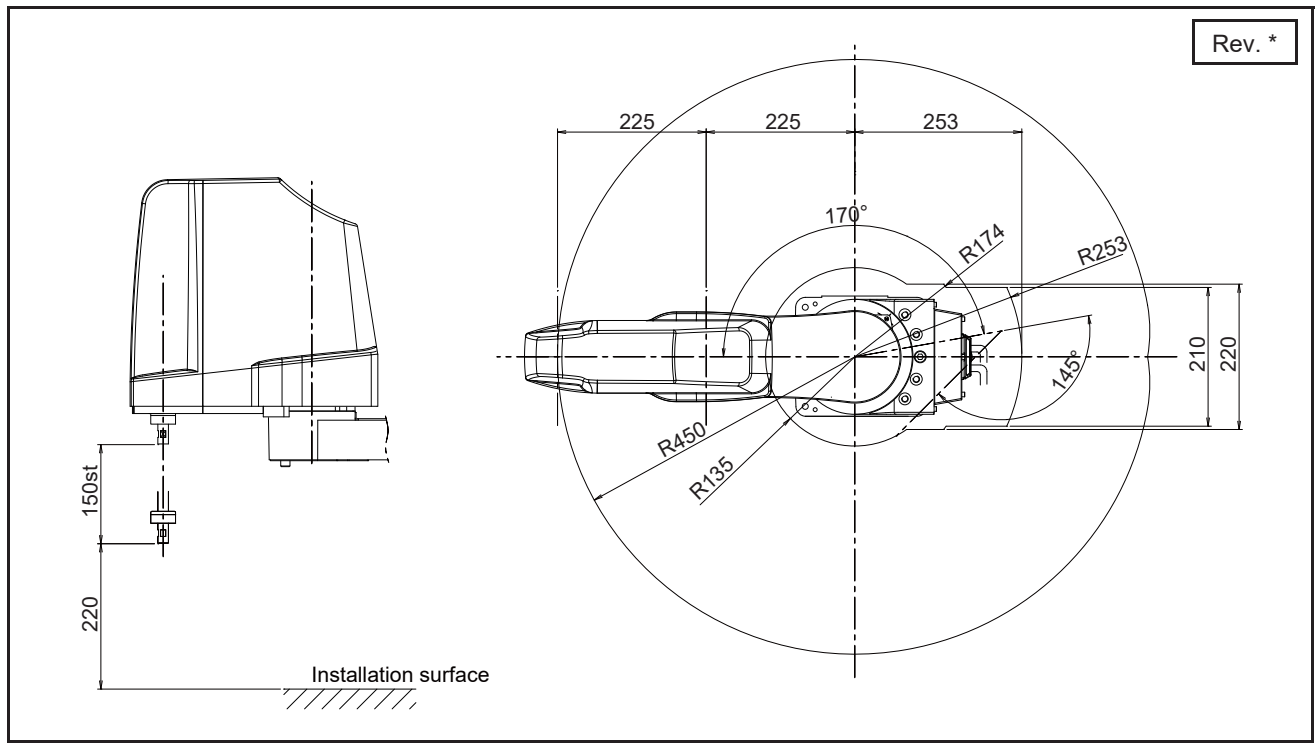

Fig.: Operating range diagram of RH-3FRH4515

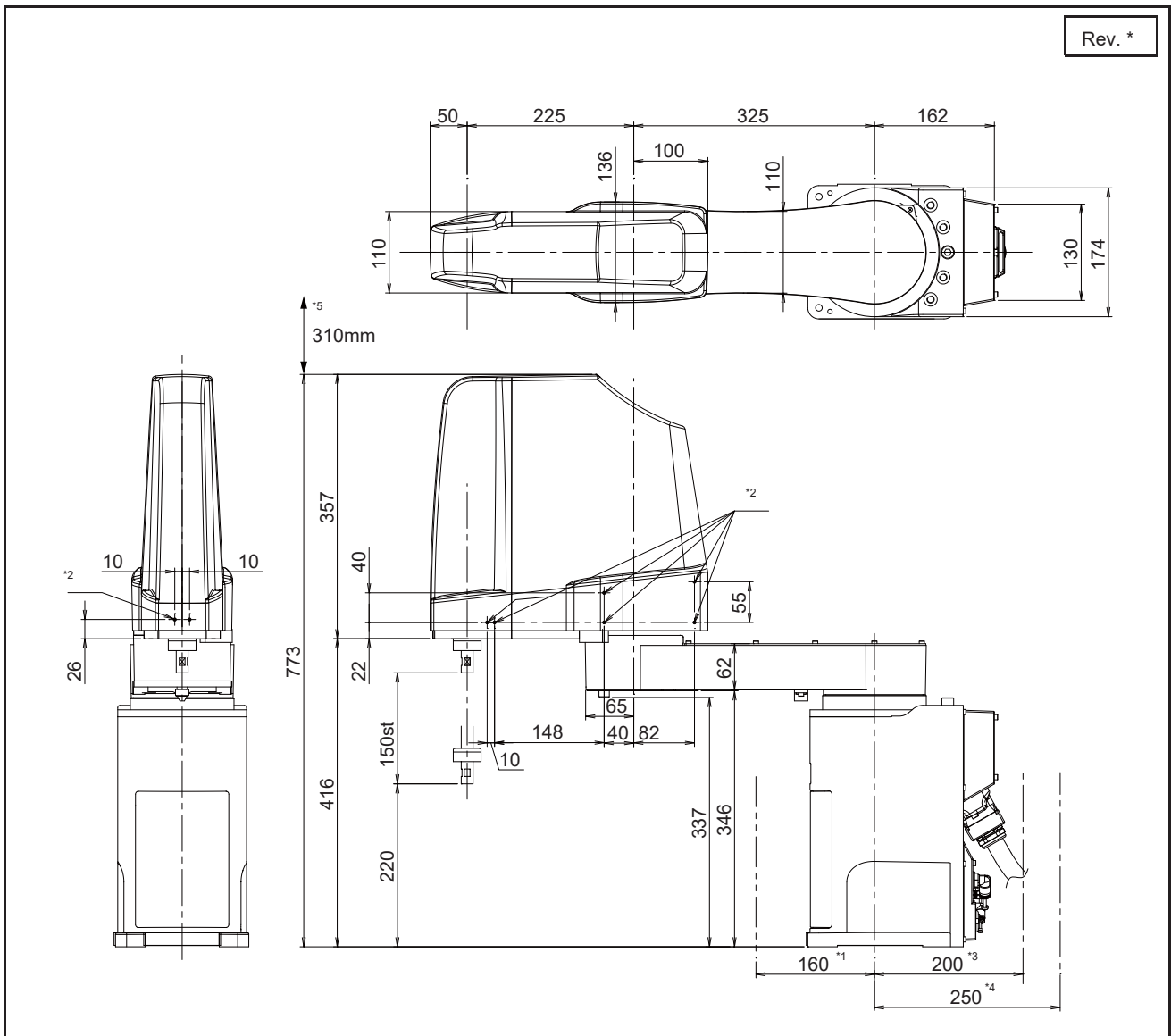

Fig.: Outside dimensions of RH-3FRH5515

*1 Indicates the space necessary to replace the battery.

*2 Indicates the screw holes (M4 / depth 6mm) for fixing user wiring/piping. (Six places on both sides of No.2 arm, two places on the front surface.)

*3 The distance to the minimum bendable radius of the machine cable.

*4 Indicates the space required to connect the machine cable.

*5 Space required to install/remove the cover.

Note) Refer to Fig.: Mechanical interface and Installation surface (RH-3FRH series) for the mechanical interface section and installation base section dimensions.

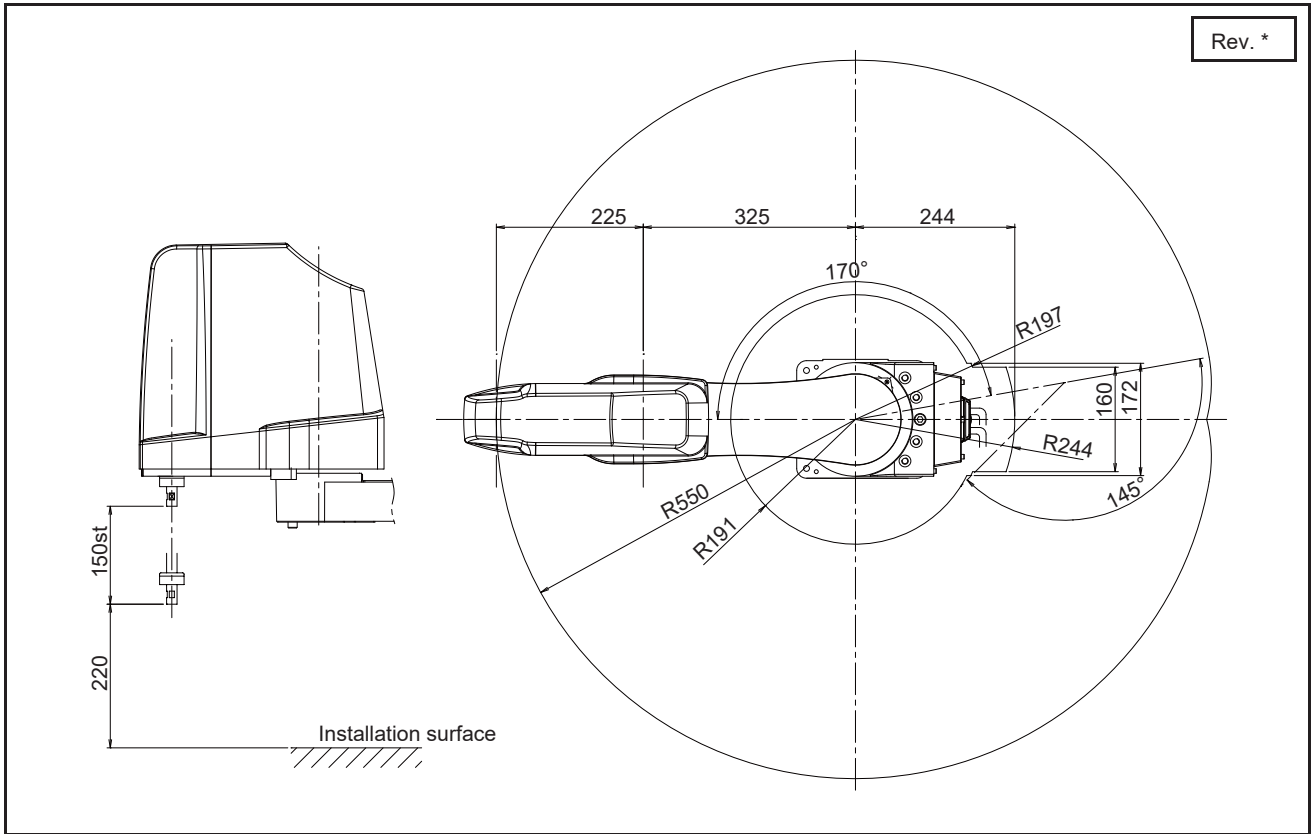

Fig.: Operating range diagram of RH-3FRH5515

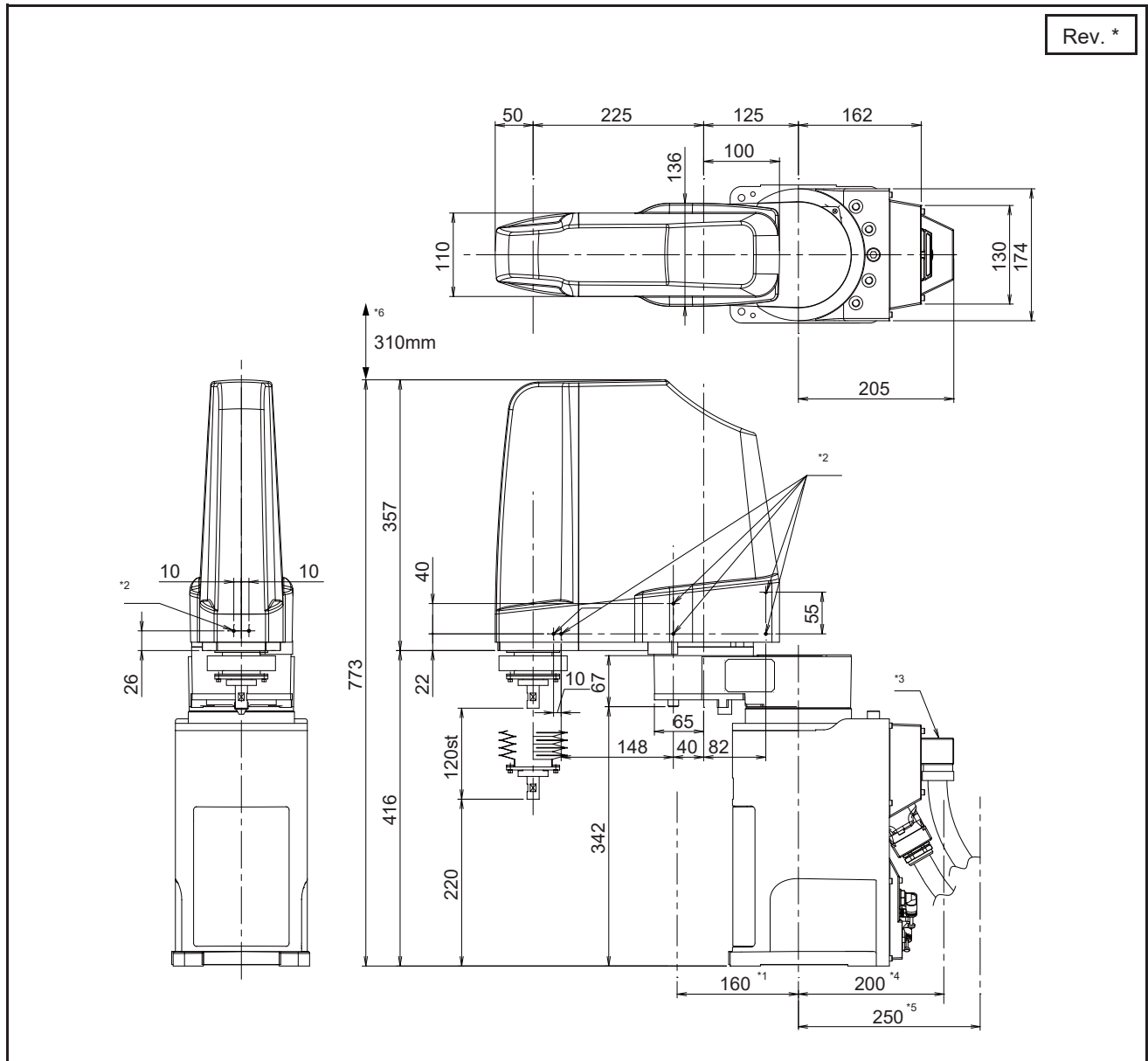

Fig.: Outside dimensions of RH-3FRH3512C

- *1 Indicates the space necessary to replace the battery.
- *2 Indicates the screw holes (M4 / depth 6mm) for fixing user wiring/piping. (Six places on both sides of No.2 arm, two places on the front surface.)
- *3 This duct is provided on robots with clean specifications.
- *4 The distance to the minimum bendable radius of the machine cable.
- *5 Indicates the space required to connect the machine cable.
- *6 Space required to install/remove the cover.

Note) Refer to Fig.: Mechanical interface and Installation surface (RH-3FRH series) for the mechanical interface section and installation base section dimensions.

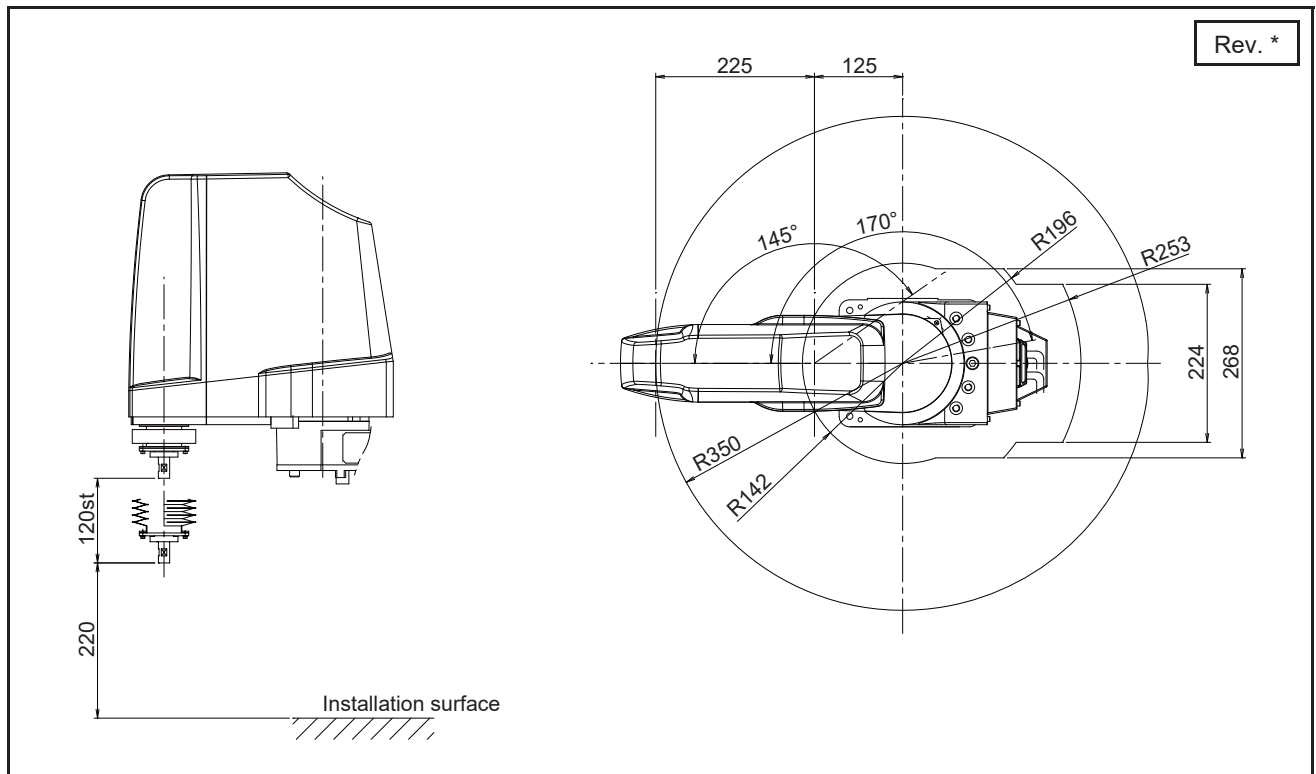

Fig.: Operating range diagram of RH-3FRH3512C

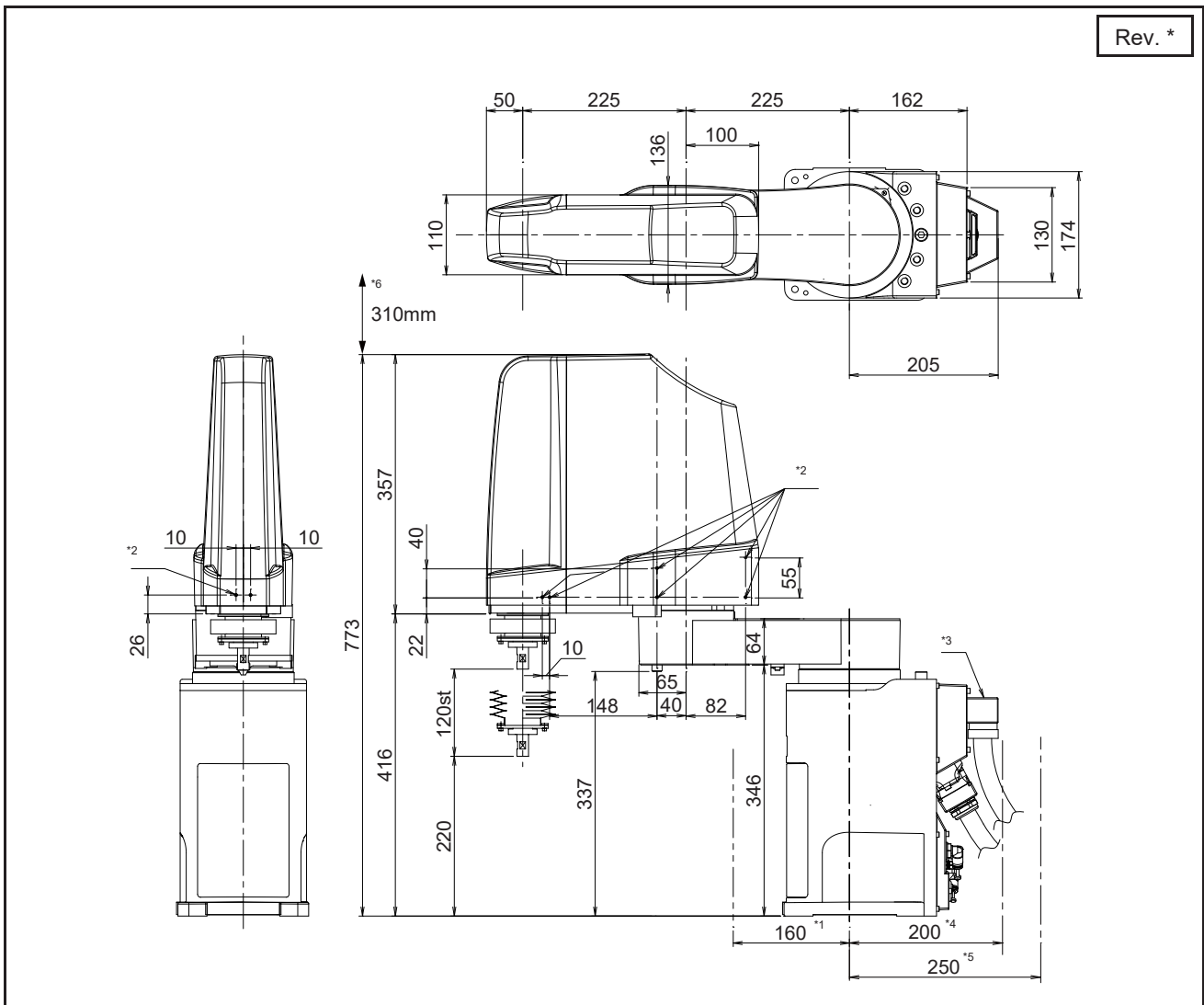

Fig.: Outside dimensions of RH-3FRH4512C

- *1 Indicates the space necessary to replace the battery.
- *2 Indicates the screw holes (M4 / depth 6mm) for fixing user wiring/piping. Six places on both sides of No.2 arm, two places on the front surface.
- *3 This duct is provided on robots with clean specifications.
- *4 The distance to the minimum bendable radius of the machine cable.
- *5 Indicates the space required to connect the machine cable.
- *6 Space required to install/remove the cover.

Note) Refer to Fig.: Mechanical interface and Installation surface (RH-3FRH series) for the mechanical interface section and installation base section dimensions.

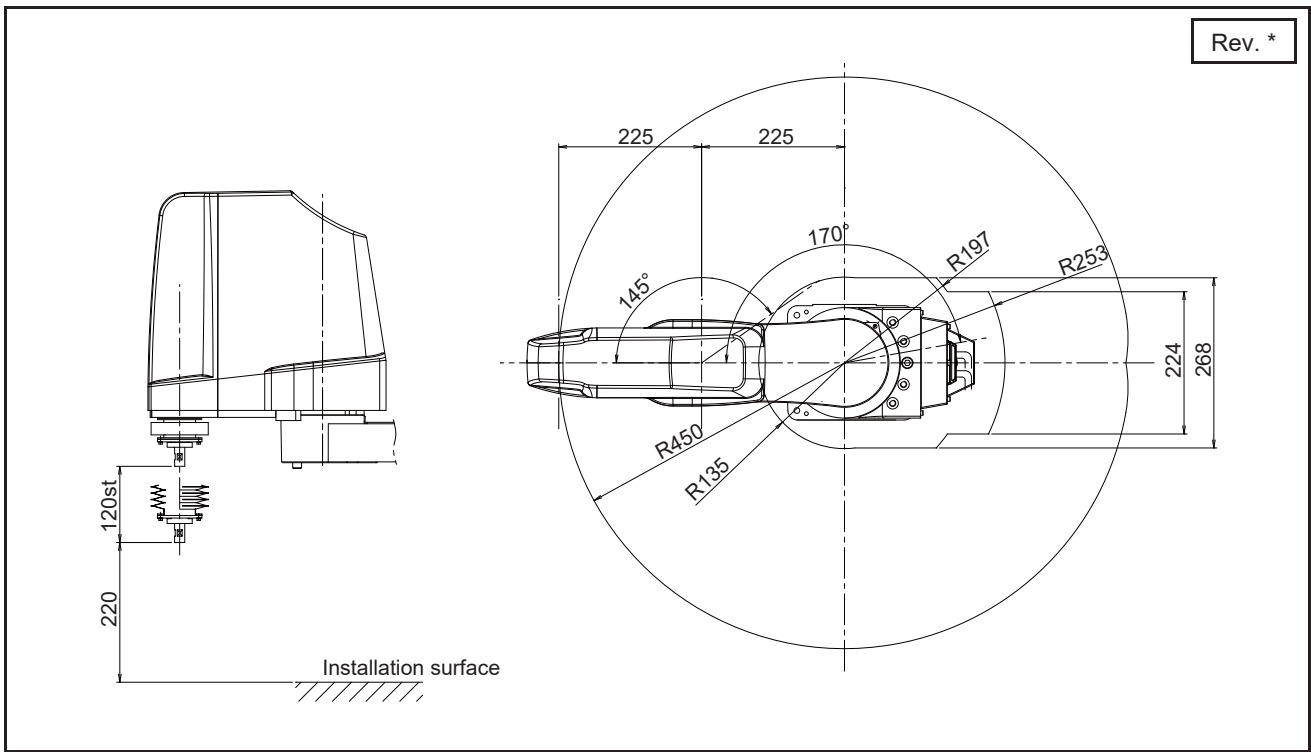

Fig.: Operating range diagram of RH-3FRH4512C

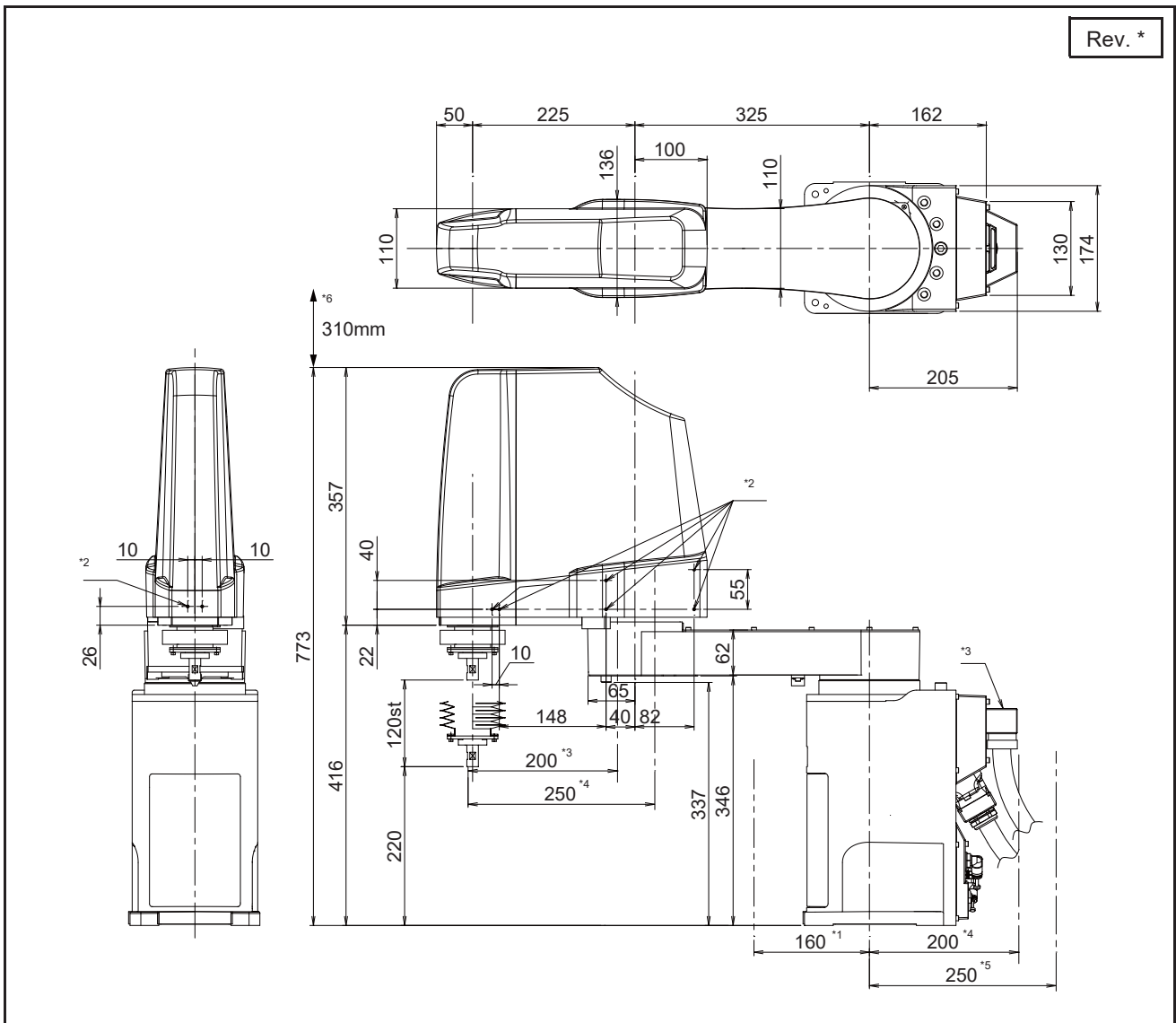

Fig.: Outside dimensions of RH-3FRH5512C

- *1 Indicates the space necessary to replace the battery.
- *2 Indicates the screw holes (M4 / depth 6mm) for fixing user wiring/piping. (Six places on both sides of No.2 arm, two places on the front surface.)
- *3 This duct is provided on robots with clean specifications.
- *4 The distance to the minimum bendable radius of the machine cable.
- *5 Indicates the space required to connect the machine cable.
- *6 Space required to install/remove the cover.

Note) Refer to Fig.: Mechanical interface and Installation surface (RH-3FRH series) for the mechanical interface section and installation base section dimensions.

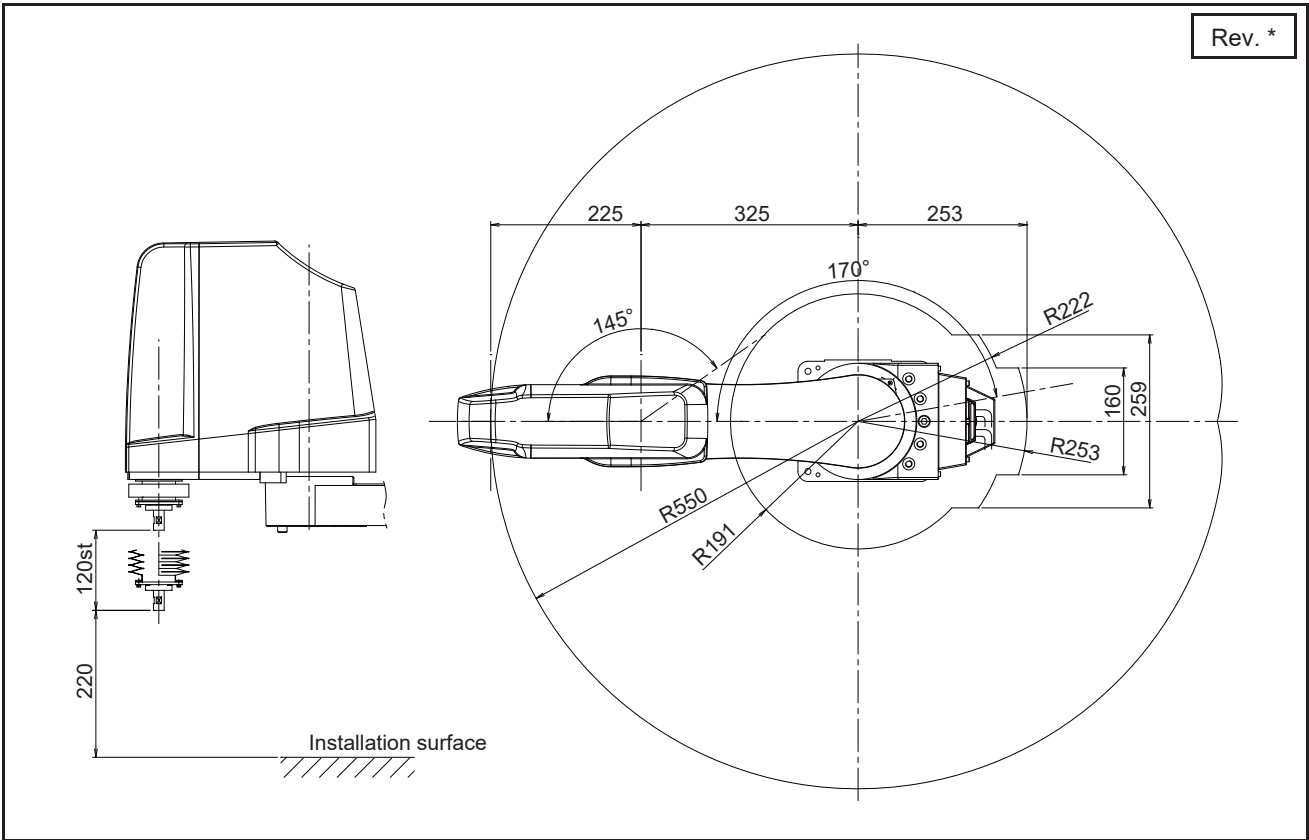

Fig.: Operating range diagram of RH-3FRH5512C

Outside dimensions • Operating range diagram (RH-6FRH series)

Standard Specification

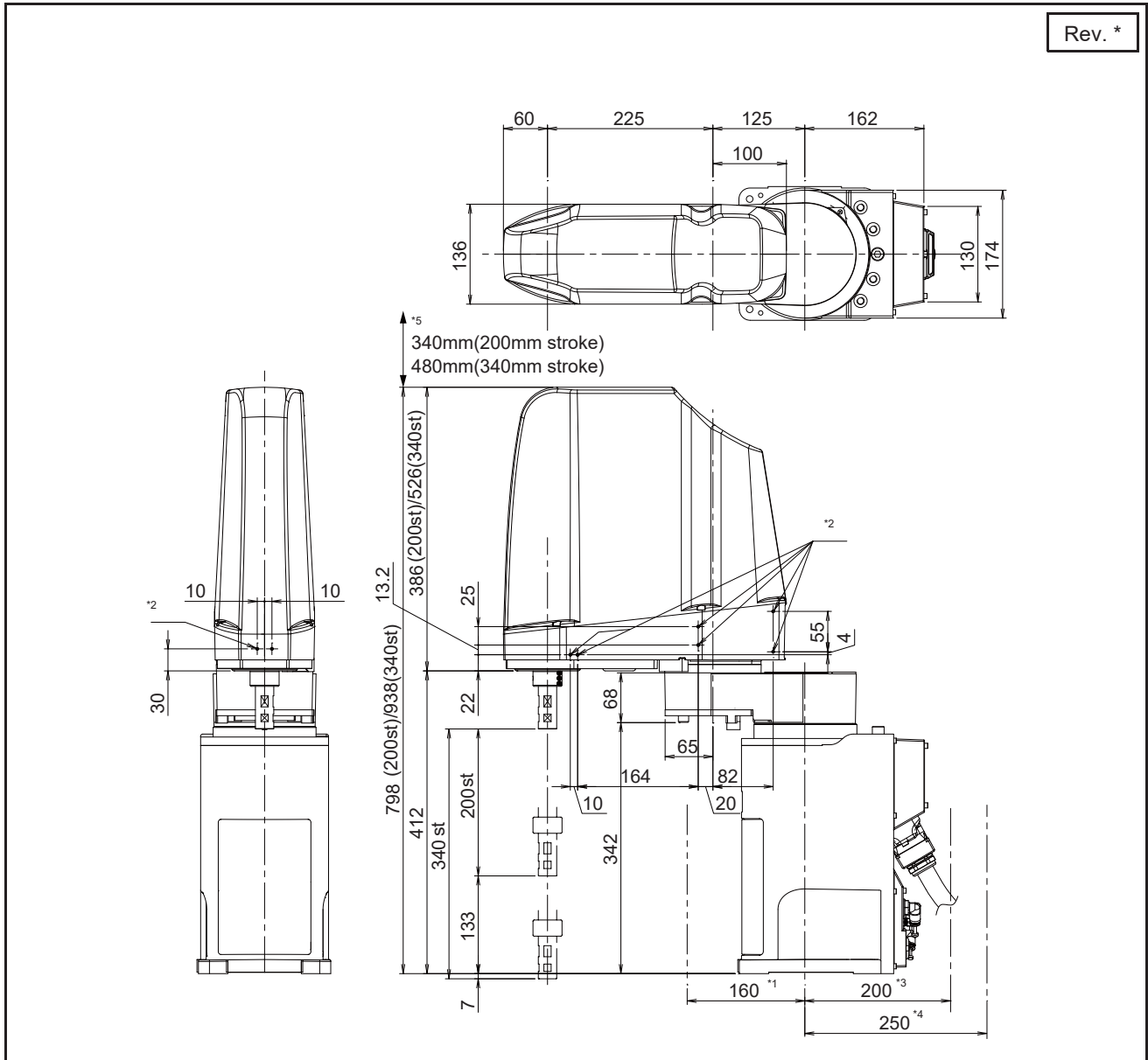

Fig.: Outside dimensions of RH-6FRH35xx

- *1 Indicates the space necessary to replace the battery.
- *2 Indicates the screw holes (M4 / depth 6mm) for fixing user wiring/piping. (Six places on both sides of No.2 arm, two places on the front surface. Refer to Fig.: Location of screw holes for fixing wiring/piping (RH-6FRH series))
- *3 The distance to the minimum bendable radius of the machine cable.
- *4 Indicates the space required to connect the machine cable.
- *5 Space required to install/remove the cover.

Note) Refer to Fig.: Mechanical interface and Installation surface (RH-6FRH series) for the mechanical interface section and installation base section dimensions.

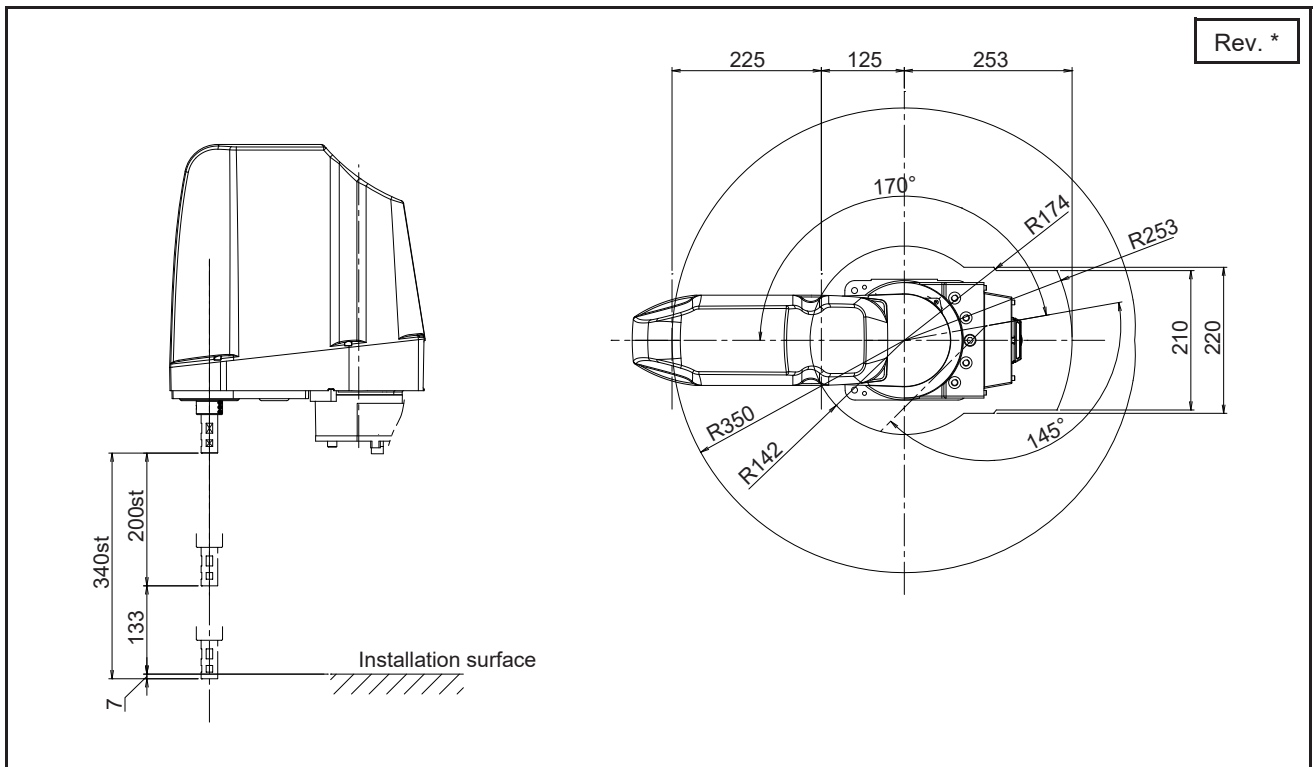

Fig.: Operating range diagram of RH-6FRH35xx

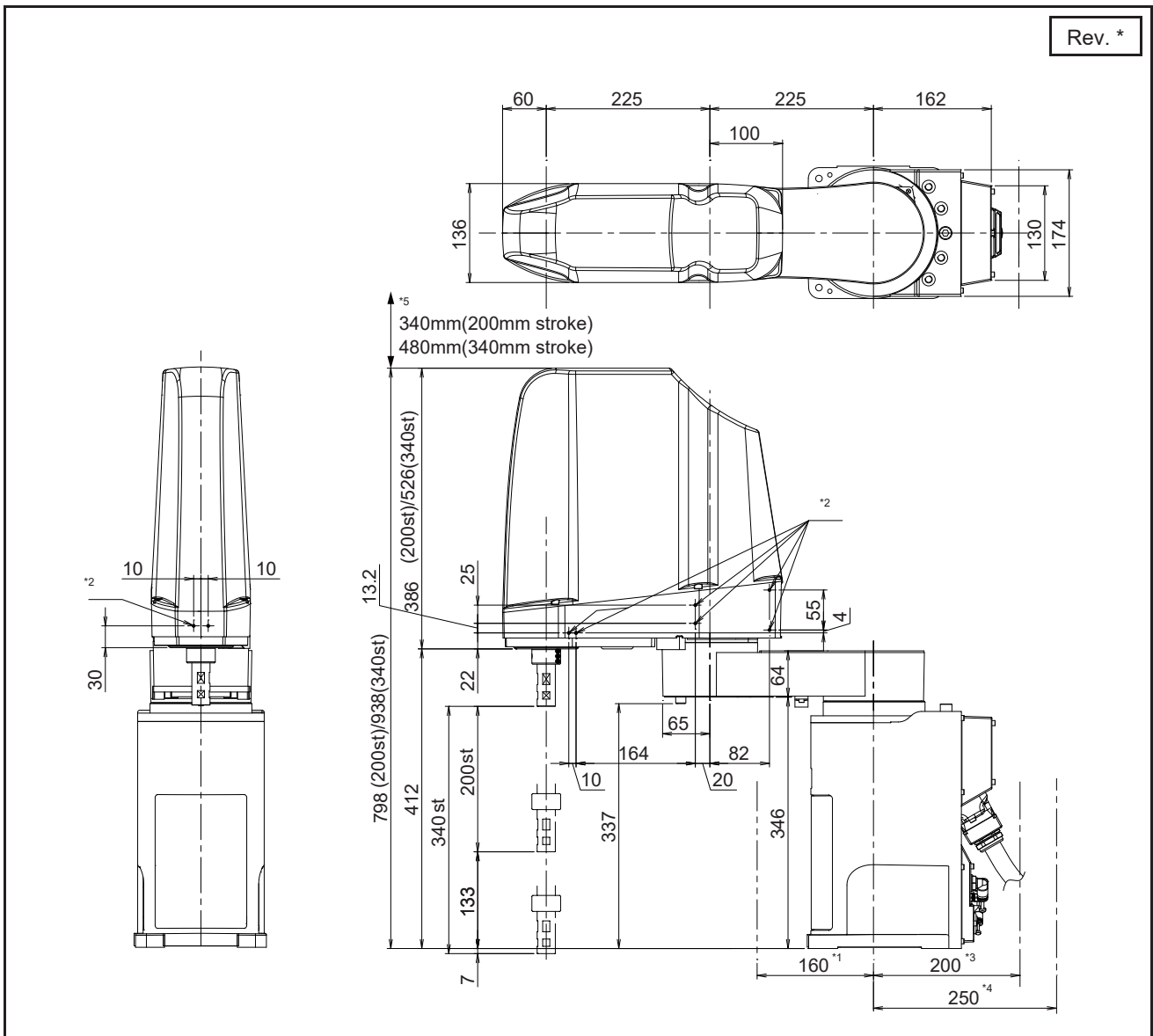

Fig.: Outside dimensions of RH-6FRH45xx

*1 Indicates the space necessary to replace the battery.

*2 Indicates the screw holes (M4 / depth 6mm) for fixing user wiring/piping. (Six places on both sides of No.2 arm, two places on the front surface. Refer to Fig.: Location of screw holes for fixing wiring/piping (RH-6FRH series))

*3 The distance to the minimum bendable radius of the machine cable.

*4 Indicates the space required to connect the machine cable.

*5 Space required to install/remove the cover.

Note) Refer to Fig.: Mechanical interface and Installation surface (RH-6FRH series) for the mechanical interface section and installation base section dimensions.

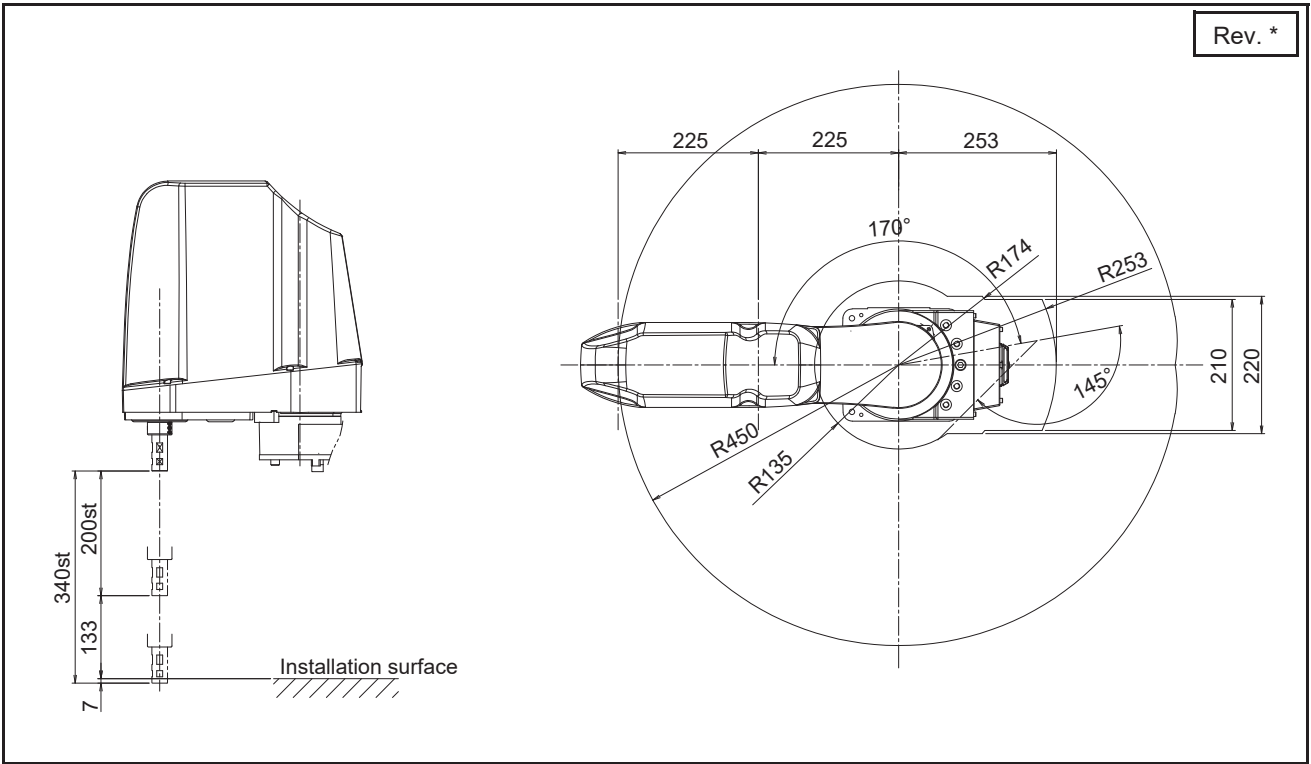

Fig.: Operating range diagram of RH-6FRH45xx

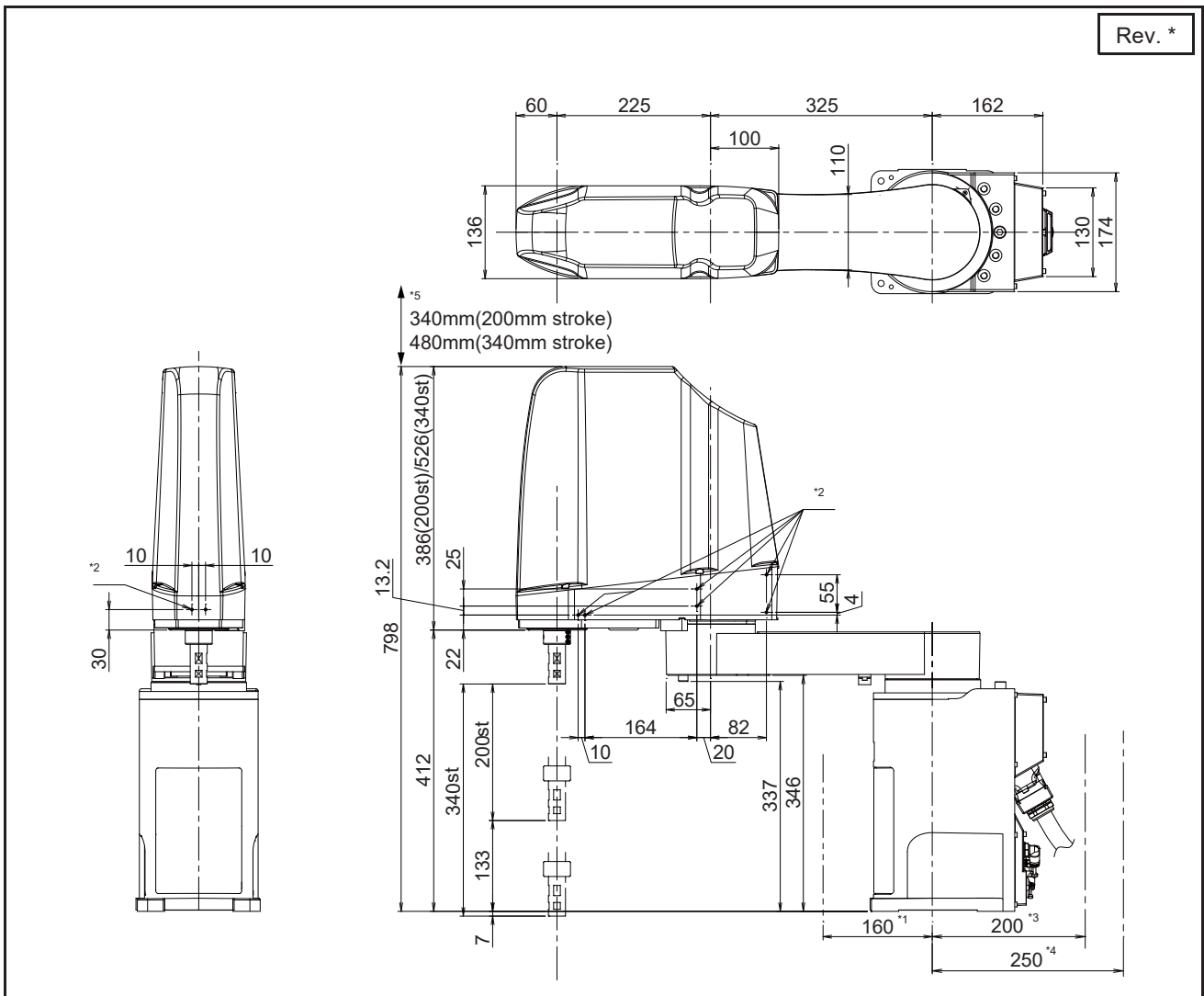

Fig.: Outside dimensions of RH-6FRH55xx

*1 Indicates the space necessary to replace the battery.

*2 Indicates the screw holes (M4 / depth 6mm) for fixing user wiring/piping. (Six places on both sides of No.2 arm, two places on the front surface. Refer to Fig.: Location of screw holes for fixing wiring/piping (RH-6FRH series))

*3 The distance to the minimum bendable radius of the machine cable.

*4 Indicates the space required to connect the machine cable.

*5 Space required to install/remove the cover.

Note) Refer to Fig.: Mechanical interface and Installation surface (RH-6FRH series) for the mechanical interface section and installation base section dimensions.

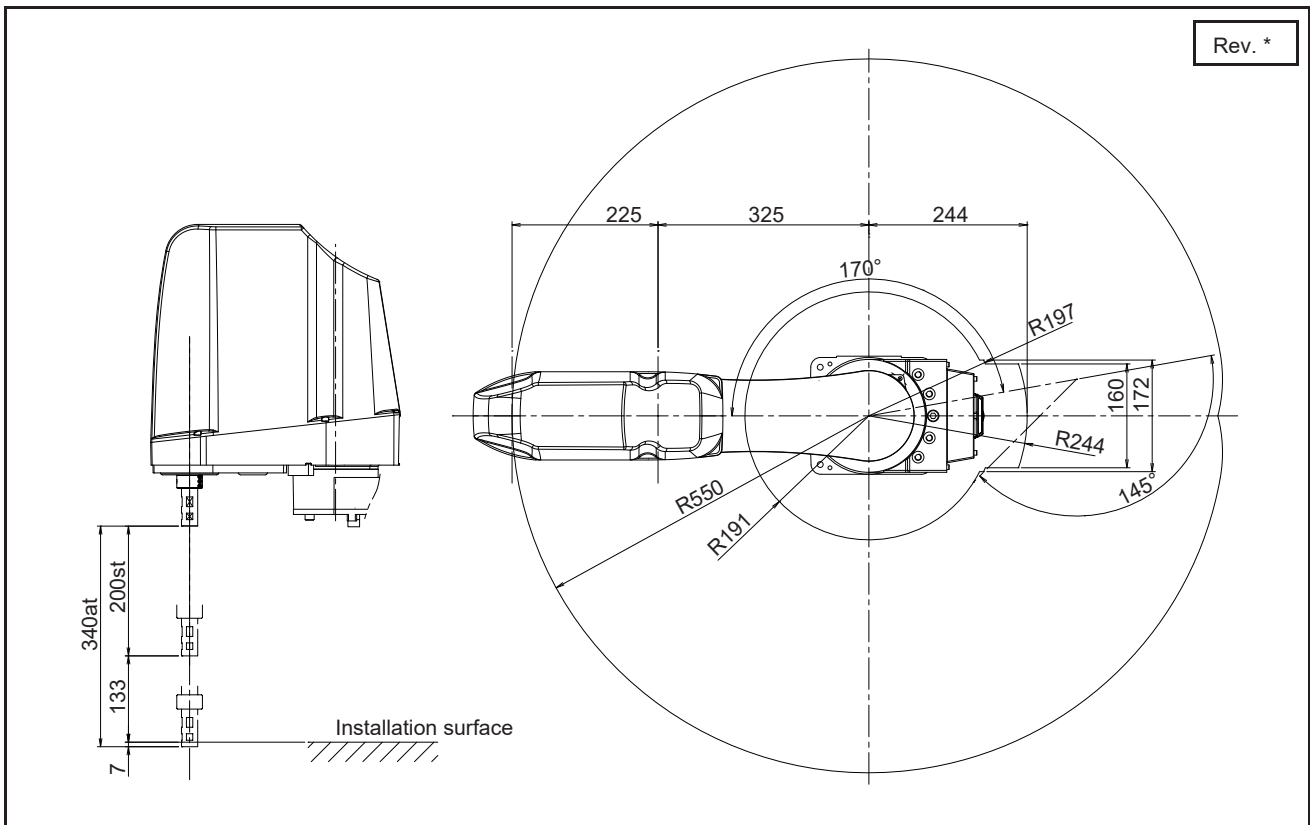

Fig.: Operating range diagram of RH-6FRH55xx

Rev. *

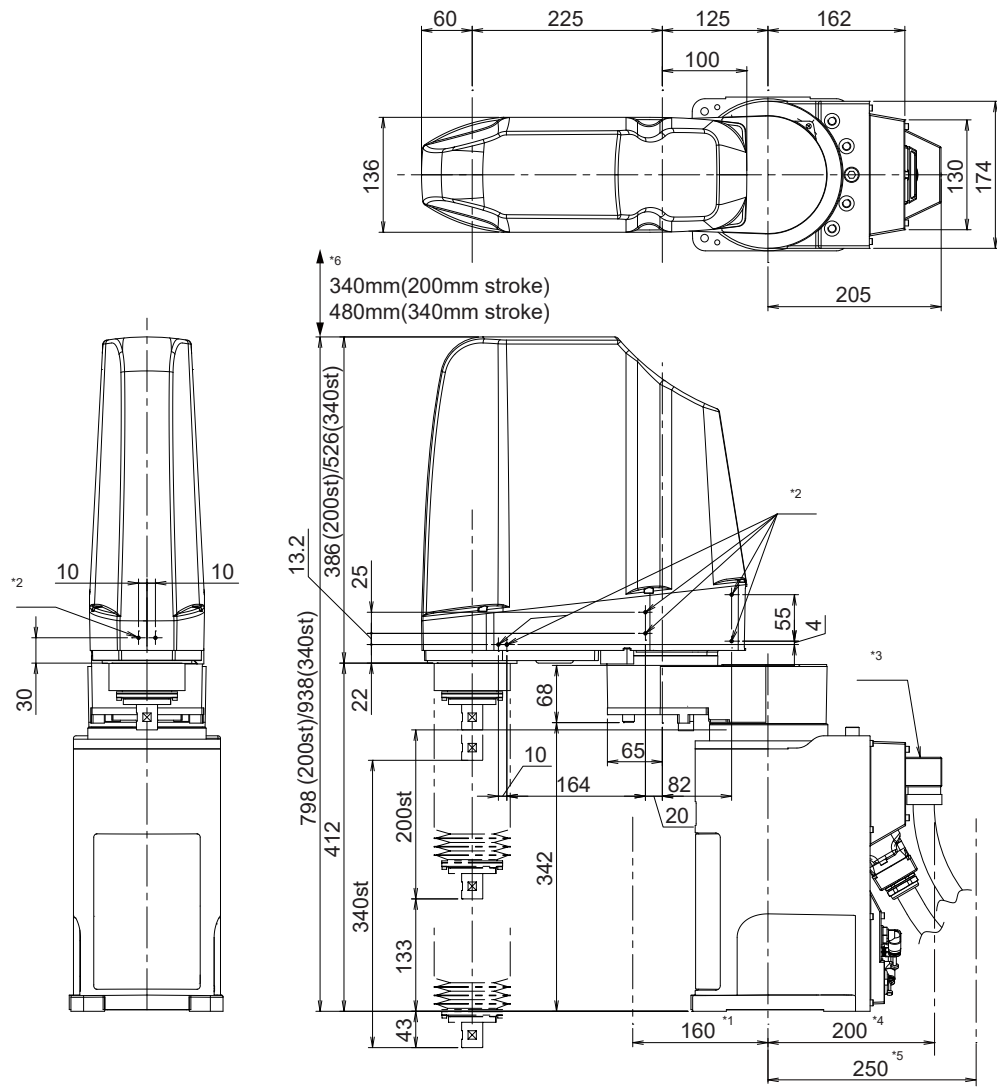

Fig.: Outside dimensions of RH-6FRH35xxC/M

- *1 Indicates the space necessary to replace the battery.
- *2 Indicates the screw holes (M4 / depth 6mm) for fixing user wiring/piping. (Six places on both sides of No.2 arm, two places on the front surface. Refer to Fig.: Location of screw holes for fixing wiring/piping (RH-6FRH series))
- *3 This duct (φ25 / total length: 3m) is provided on robots with clean specifications. Be careful for the hand etc. not to interfere and arrange the duct.
- *4 The distance to the minimum bendable radius of the machine cable.
- *5 Indicates the space required to connect the machine cable.
- *6 Space required to install/remove the cover.

Note) Refer to Fig.: Mechanical interface and Installation surface (RH-6FRH series) for the mechanical interface section and installation base section dimensions.

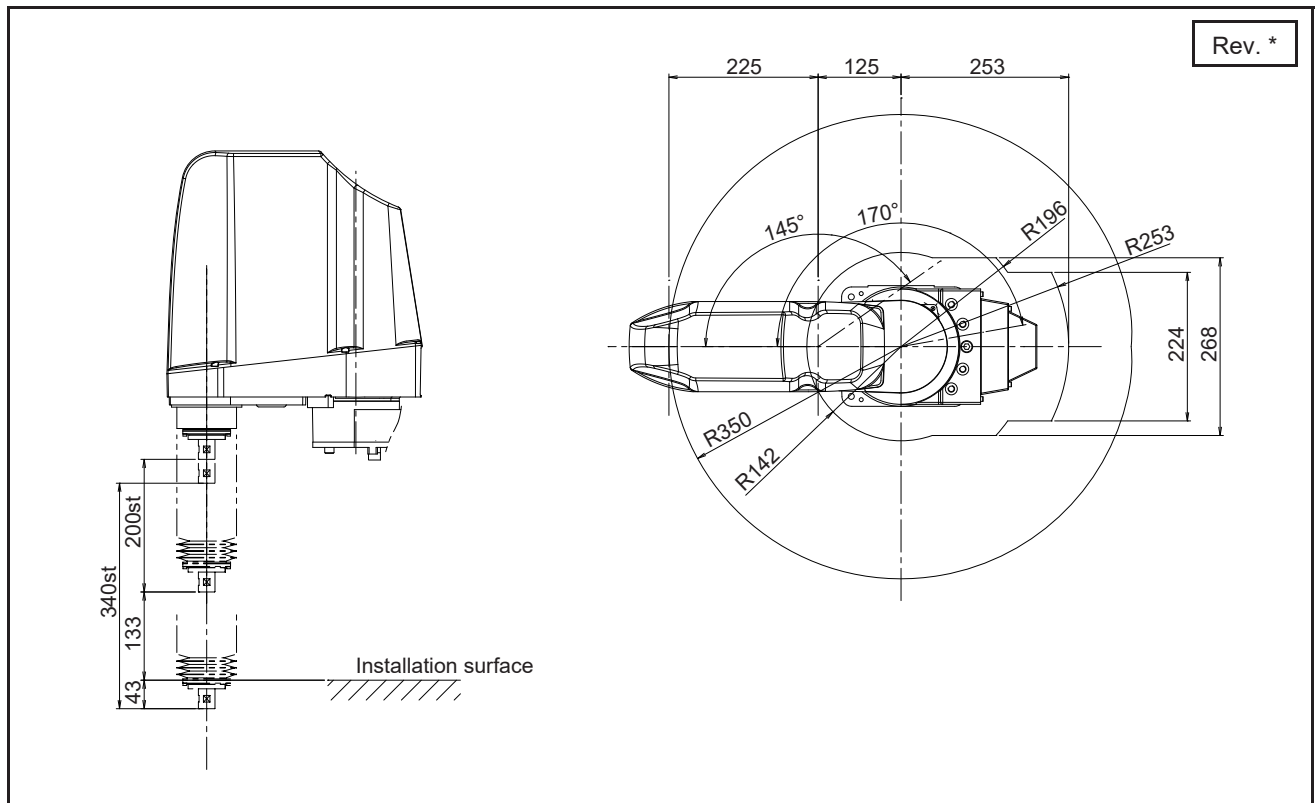

Fig.: Operating range diagram of RH-6FRH35xxC/M

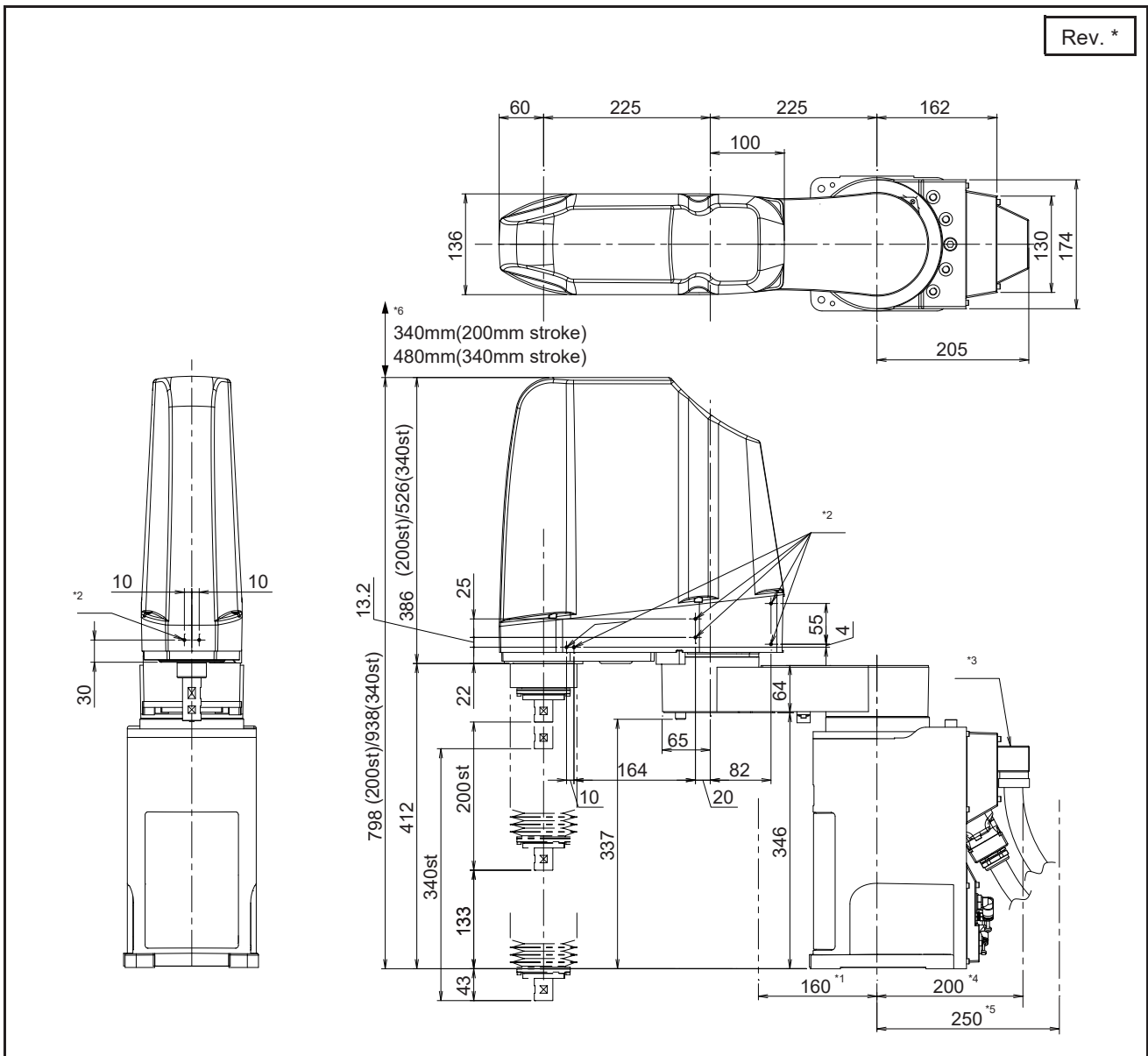

Fig.: Outside dimensions of RH-6FRH45xxC/M

- *1 Indicates the space necessary to replace the battery.
- *2 Indicates the screw holes (M4 / depth 6mm) for fixing user wiring/piping. (Six places on both sides of No.2 arm, two places on the front surface. Refer to Fig.: Location of screw holes for fixing wiring/piping (RH-6FRH series))
- *3 This duct (φ25 / total length: 3m) is provided on robots with clean specifications. Be careful for the hand etc. not to interfere and arrange the duct.
- *4 The distance to the minimum bendable radius of the machine cable.
- *5 Indicates the space required to connect the machine cable.
- *6 Space required to install/remove the cover.

Note) Refer to Fig.: Mechanical interface and Installation surface (RH-6FRH series) for the mechanical interface section and installation base section dimensions.

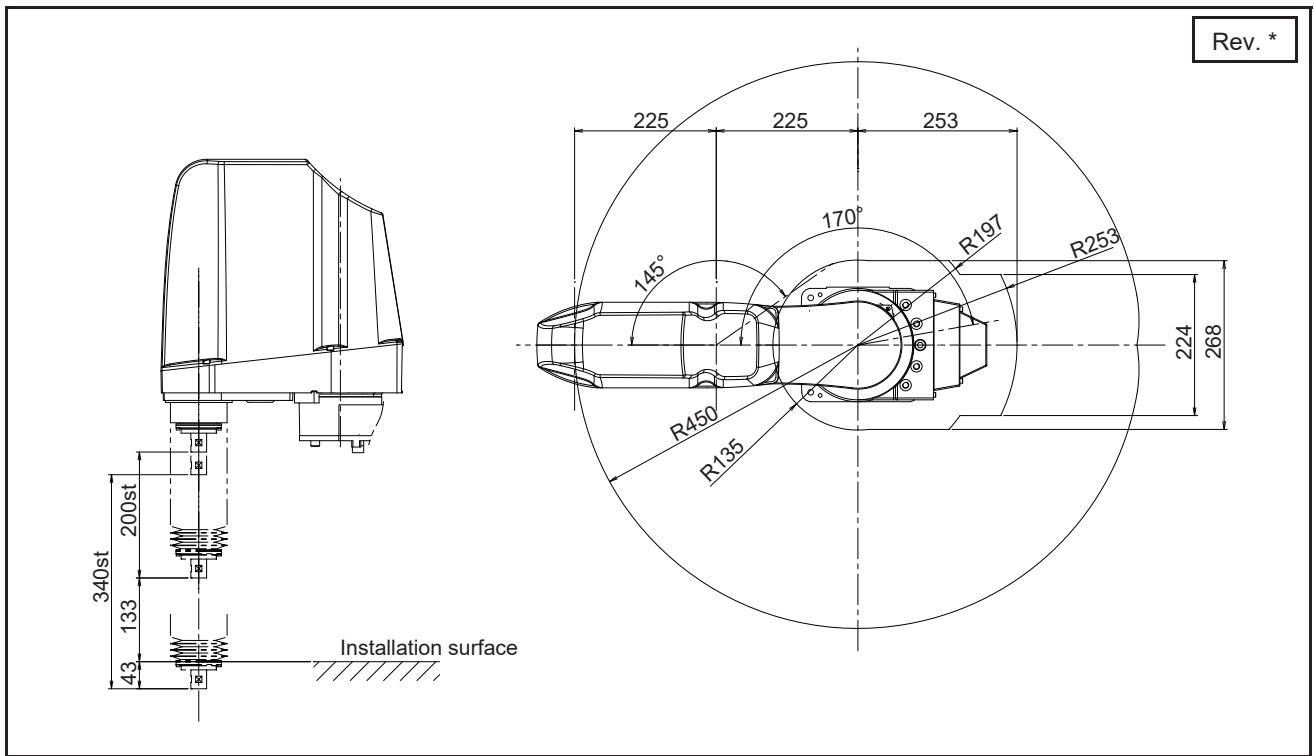

Fig.: Operating range diagram of RH-6FRH45xxC/M

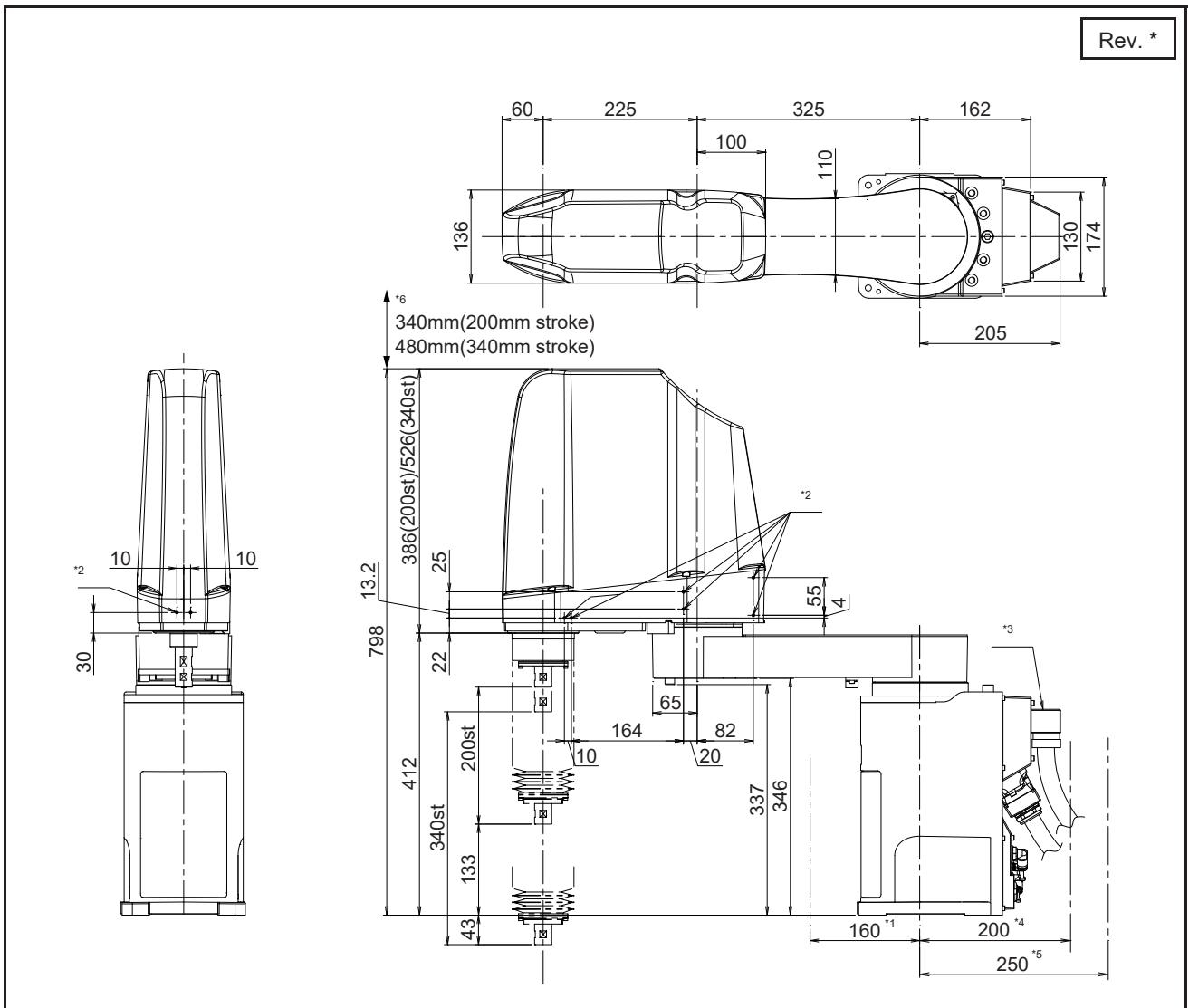

Fig.: Outside dimensions of RH-6FRH55xxC/M

*1 Indicates the space necessary to replace the battery.

*2 Indicates the screw holes (M4 / depth 6mm) for fixing user wiring/piping. (Six places on both sides of No.2 arm, two places on the front surface. Refer to Fig.: Location of screw holes for fixing wiring/piping (RH-6FRH series))

*3 This duct ($\phi 25$ / total length: 3m) is provided on robots with clean specifications. Be careful for the hand etc. not to interfere and arrange the duct.

*4 The distance to the minimum bendable radius of the machine cable.

*5 Indicates the space required to connect the machine cable.

*6 Space required to install/remove the cover.

Note) Refer to Fig.: Mechanical interface and Installation surface (RH-6FRH series) for the mechanical interface section and installation base section dimensions.

現況*
Rev.*

Robot series	Dimension A	Dimension B
RH-6FRH55xxC	253	R253
6FRH55xxM	244	R244

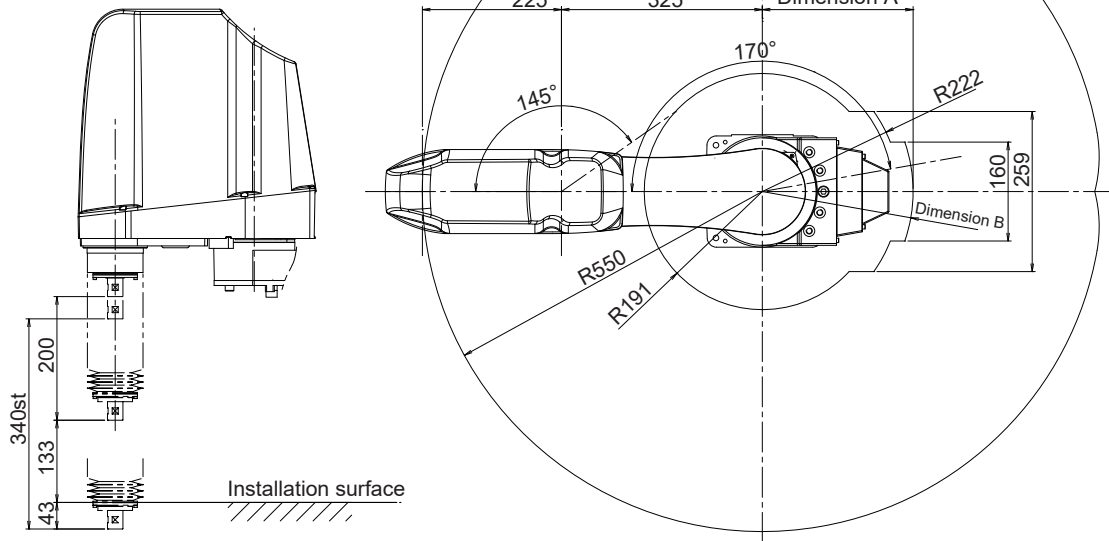

2

Fig.: Operating range diagram of RH-6FRH55xxC/M

Outside dimensions • Operating range diagram (RH-12FRH series)

Standard Specification

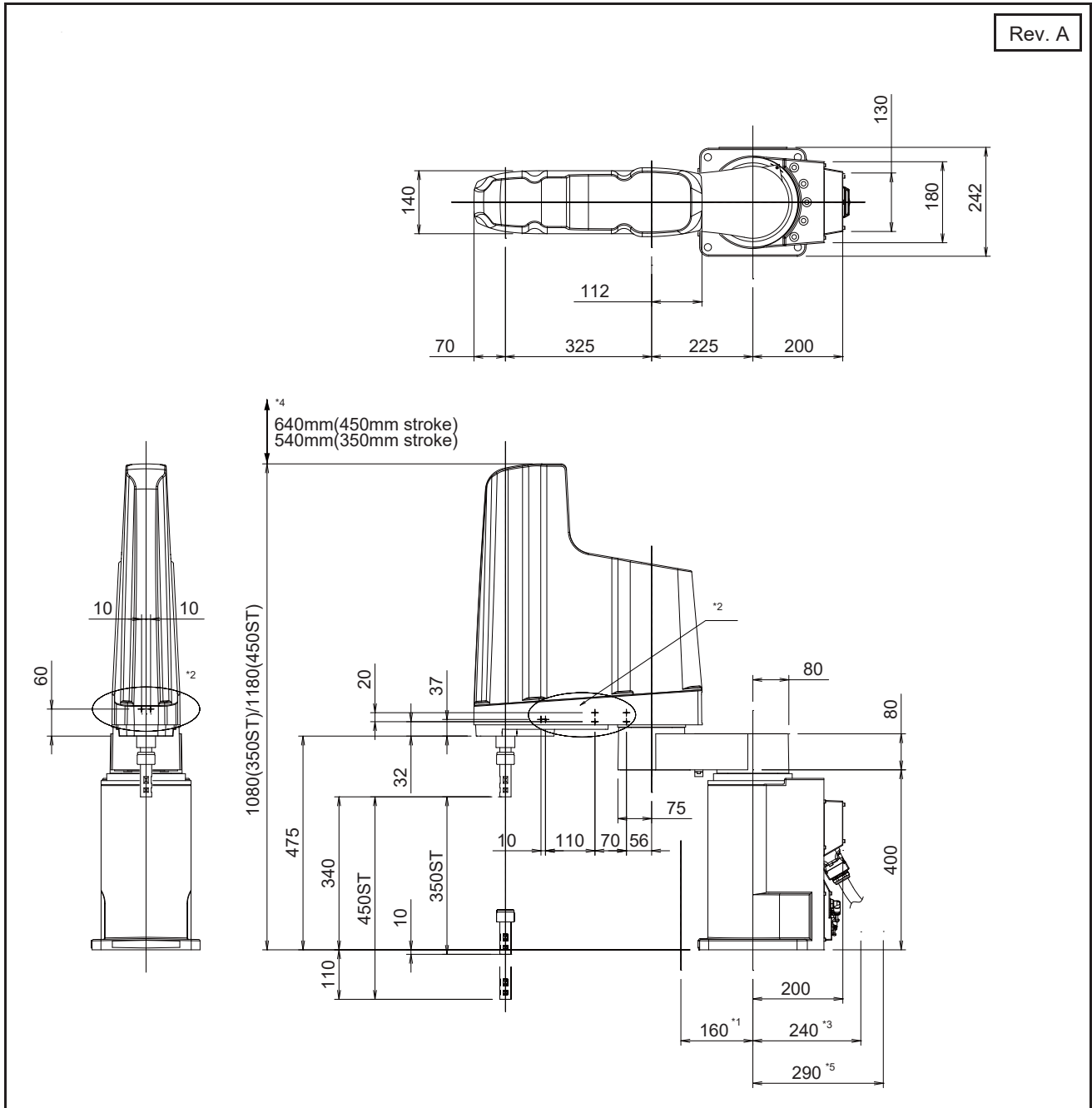

Fig.: Outside dimensions of RH-12FRH55xx

*1 Indicates the space necessary to replace the battery.

*2 Indicates screw holes for fixing user wiring/piping. (Refer to Fig.: Location of screw holes for fixing wiring/piping (RH-12FRH/20FRH series))

*3 The distance to the minimum bendable radius of the machine cable.

*4 Space required to install/remove the cover.

*5 Indicates the space required to connect the machine cable.

Note) Refer to Fig.: Mechanical interface and Installation surface of RH-12FRH series for the mechanical interface section and installation base section dimensions.

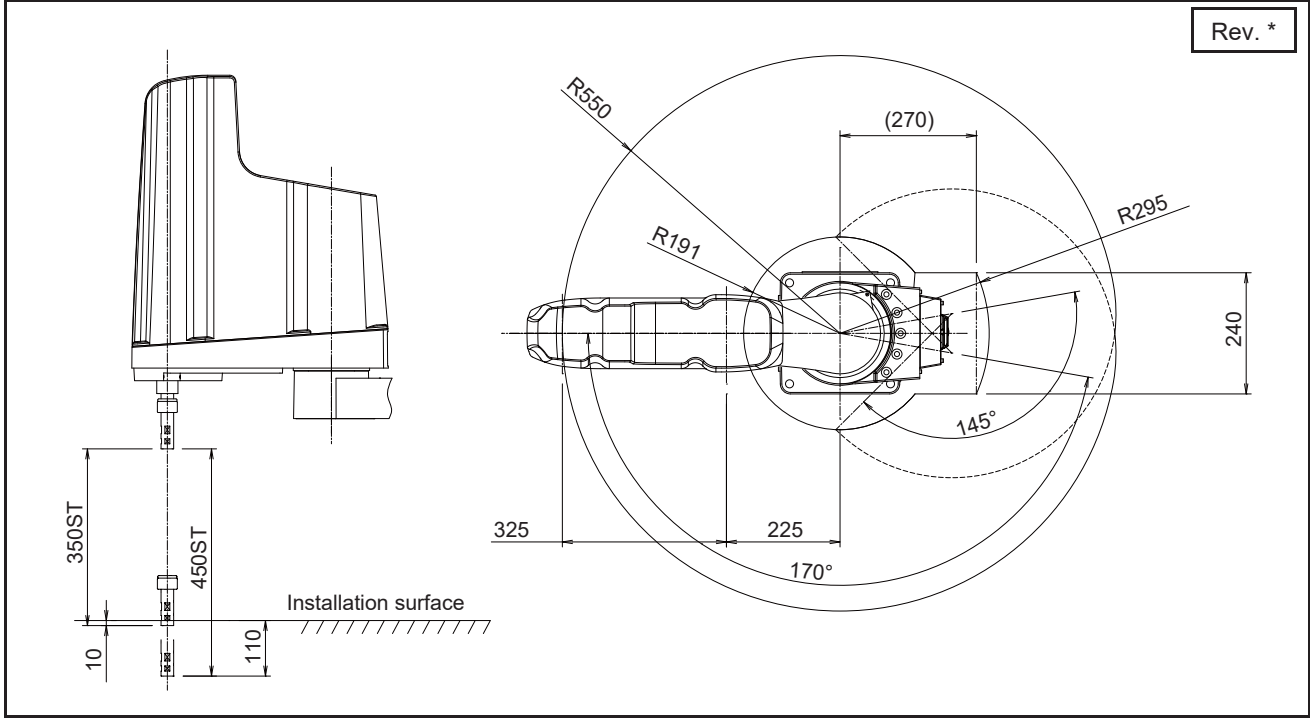

Fig.: Operating range diagram of RH-12FRH55xx

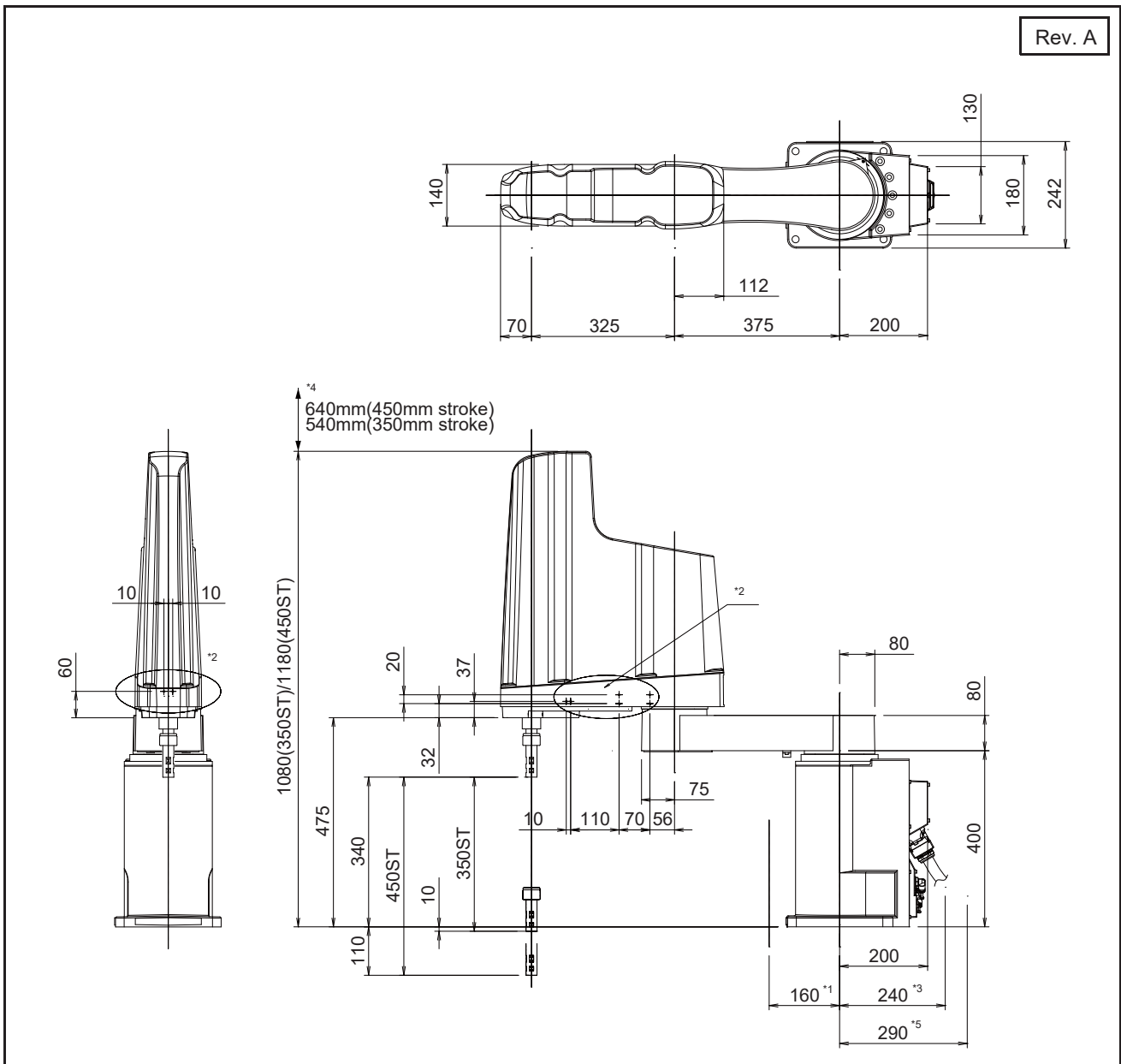

Fig.: Outside dimensions of RH-12FRH70xx

- *1 Indicates the space necessary to replace the battery.
- *2 Indicates the screw holes for fixing user wiring/piping. (Refer to Fig.: Location of screw holes for fixing wiring/piping (RH-12FRH/20FRH series))
- *3 The distance to the minimum bendable radius of the machine cable.
- *4 Space required to install/remove the cover.
- *5 Indicates the space required to connect the machine cable.

Note) Refer to Fig.: Mechanical interface and Installation surface of RH-12FRH series for the mechanical interface section and installation base section dimensions.

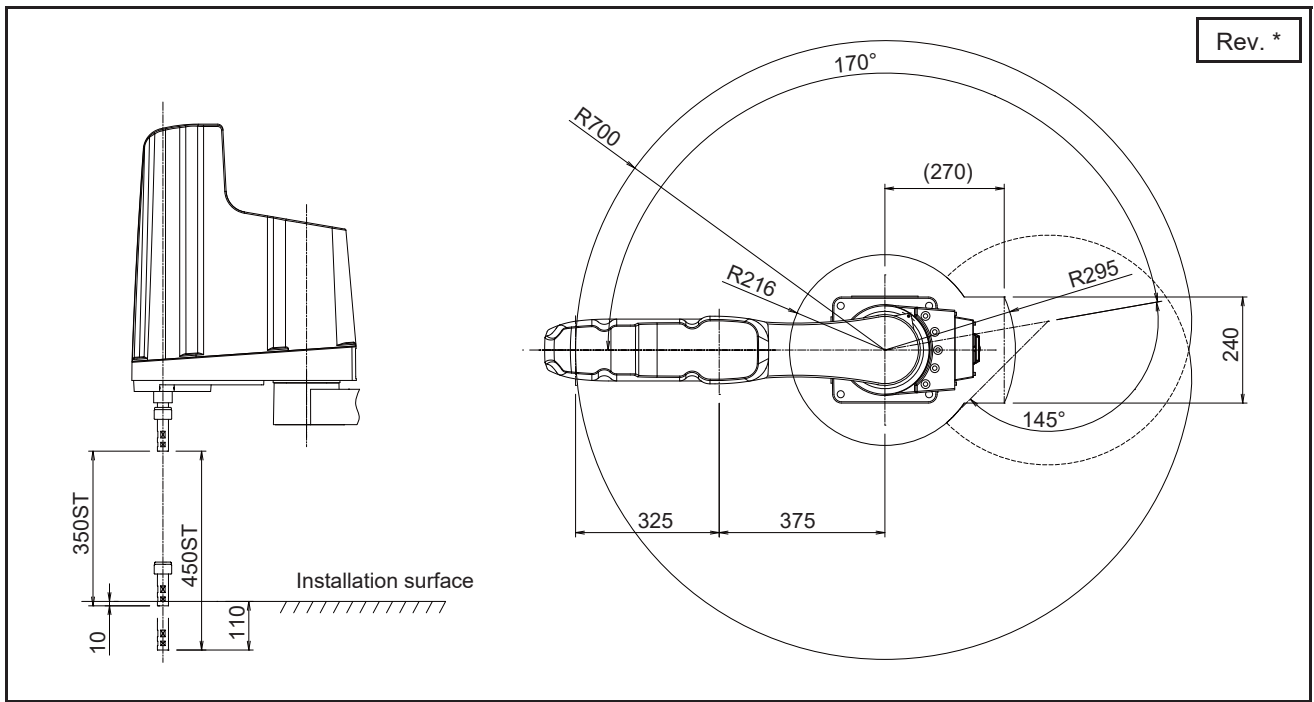

Fig.: Operating range diagram of RH-12FRH70xx

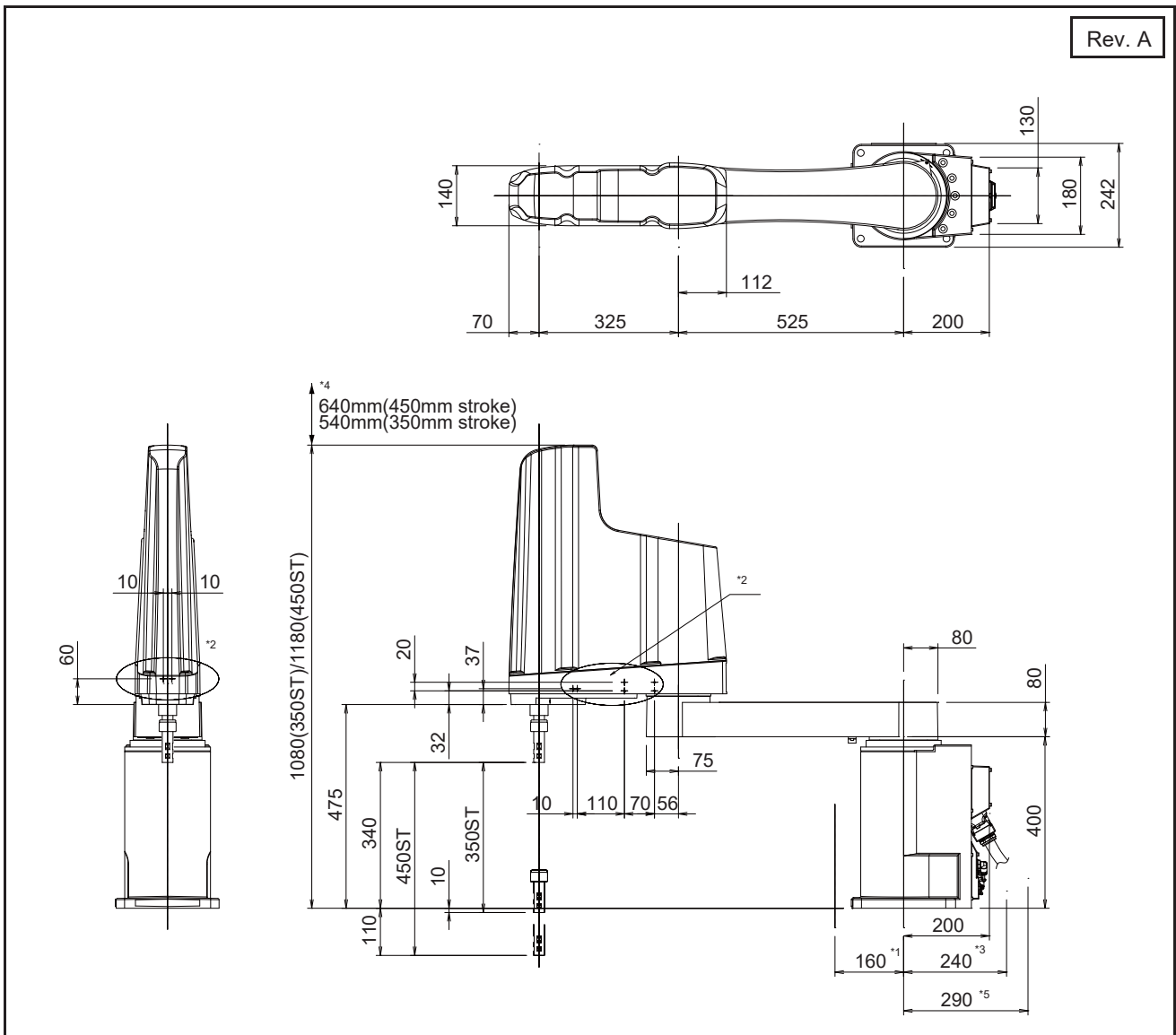

Fig.: Outside dimensions of RH-12FRH85xx

*1 Indicates the space necessary to replace the battery.

*2 Indicates the screw holes for fixing user wiring/piping. (Refer to Fig.: Location of screw holes for fixing wiring/piping (RH-12FRH/20FRH series))

*3 The distance to the minimum bendable radius of the machine cable.

*4 Space required to install/remove the cover.

*5 Indicates the space required to connect the machine cable.

Note) Refer to Fig.: Mechanical interface and Installation surface of RH-12FRH series for the mechanical interface section and installation base section dimensions.

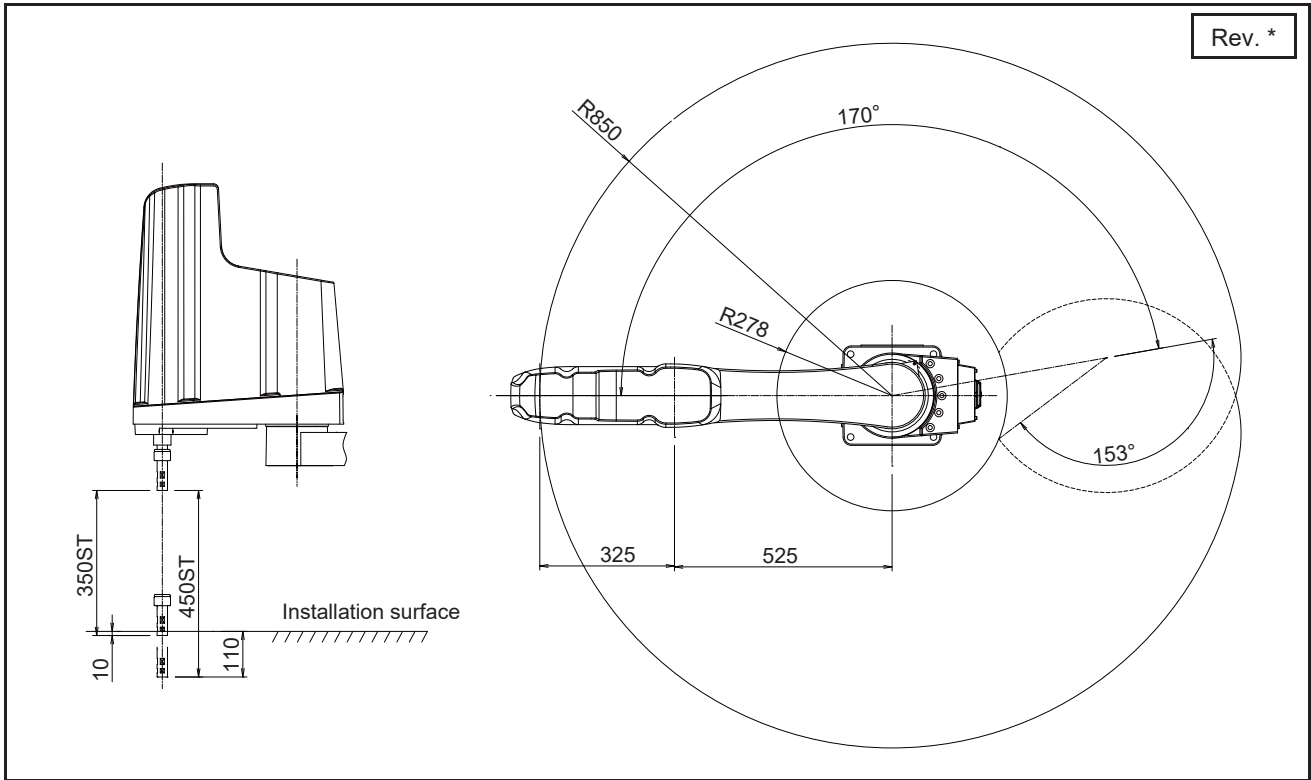

Fig.: Operating range diagram of RH-12FRH85xx

Rev. A

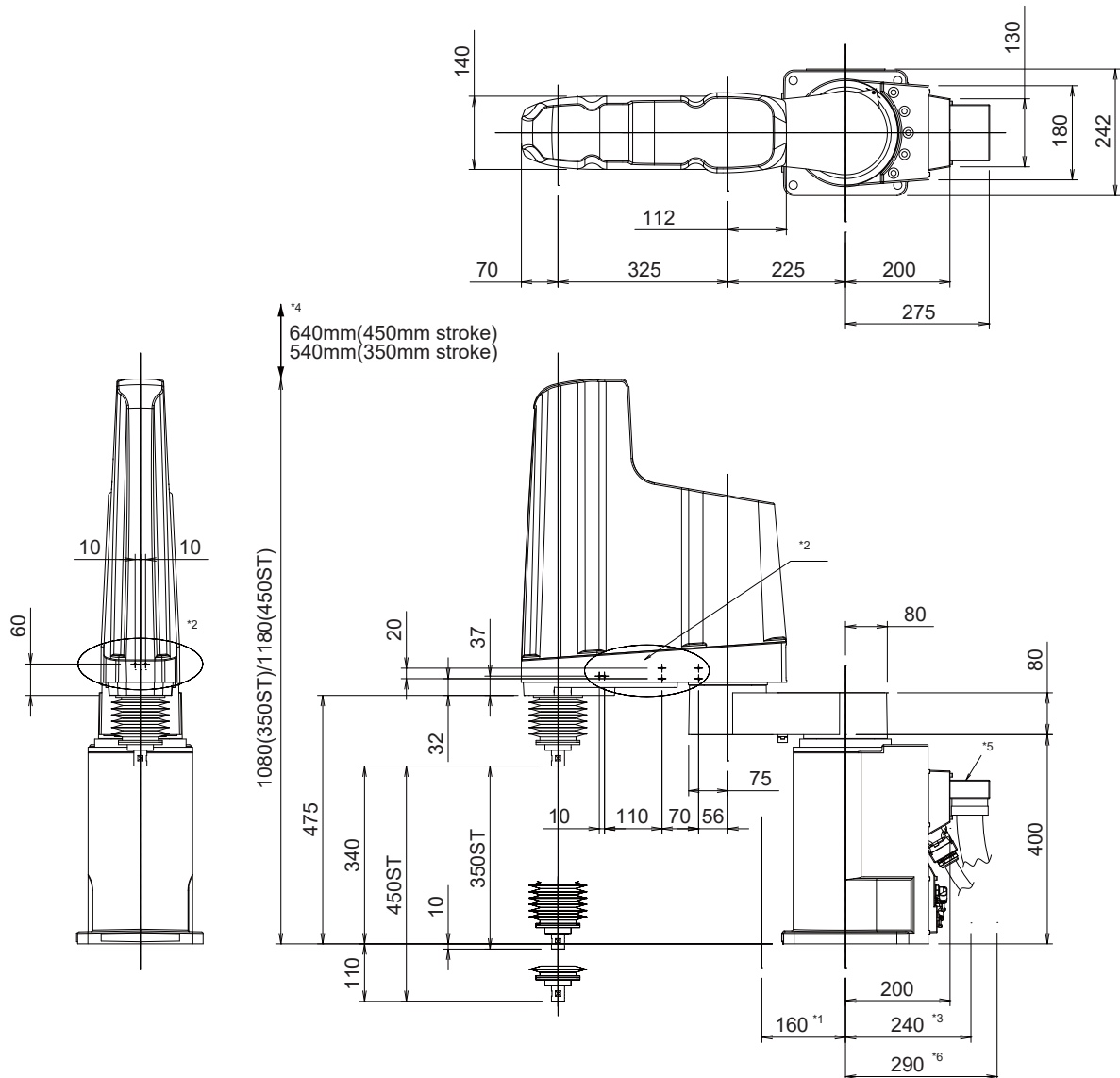

Fig.: Outside dimensions of RH-12FRH55xxC/M

- *1 Indicates the space necessary to replace the battery.
- *2 Indicates the screw holes for fixing user wiring/piping. (Refer to Fig.: Location of screw holes for fixing wiring/piping (RH-12FRH/20FRH series))
- *3 The distance to the minimum bendable radius of the machine cable.
- *4 Space required to install/remove the cover.
- *5 This duct (φ50 / total length: 2m) is provided on robots with clean specifications. Be careful for the hand etc. not to interfere and arrange the duct.
- *6 Indicates the space required to connect the machine cable.

Note) Refer to Fig.: Mechanical interface and Installation surface of RH-12FRH series for the mechanical interface section and installation base section dimensions.

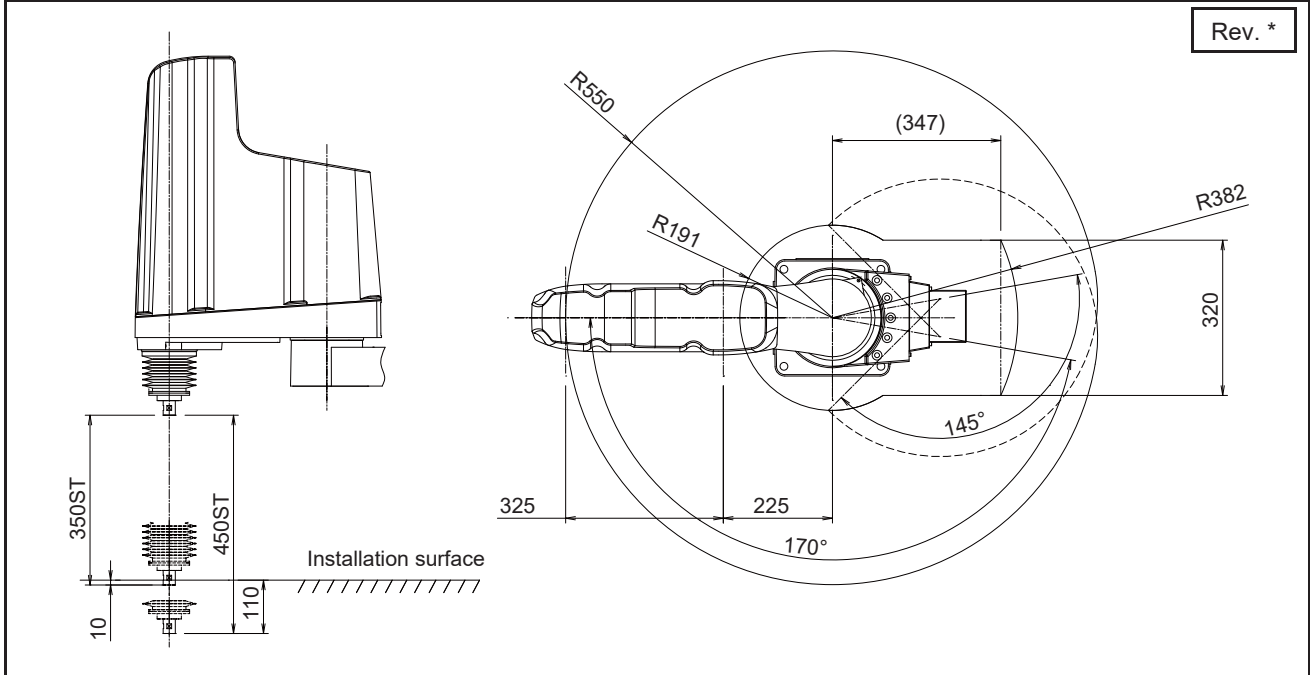

Fig.: Operating range diagram of RH-12FRH55xxC/M

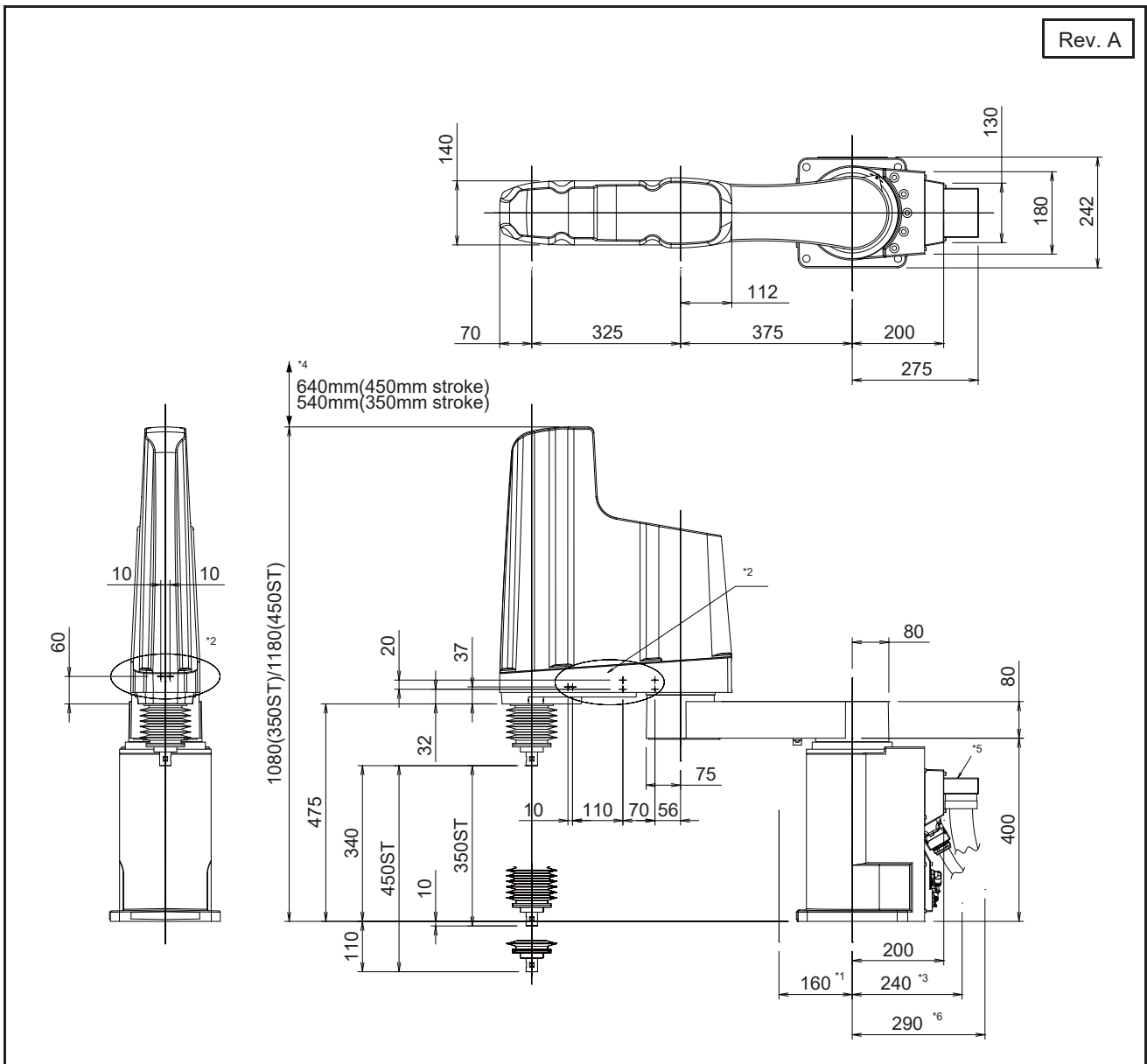

Fig.: Outside dimensions of RH-12FRH70xxC/M

- *1 Indicates the space necessary to replace the battery.
- *2 Indicates the screw holes for fixing user wiring/piping. (Refer to Fig.: Location of screw holes for fixing wiring/piping (RH-12FRH/20FRH series))
- *3 The distance to the minimum bendable radius of the machine cable.
- *4 Space required to install/remove the cover.
- *5 This duct (φ50 / total length: 2m) is provided on robots with clean specifications. Be careful for the hand etc. not to interfere and arrange the duct.
- *6 Indicates the space required to connect the machine cable.

Note) Refer to Fig.: Mechanical interface and Installation surface of RH-12FRH series for the mechanical interface section and installation base section dimensions.

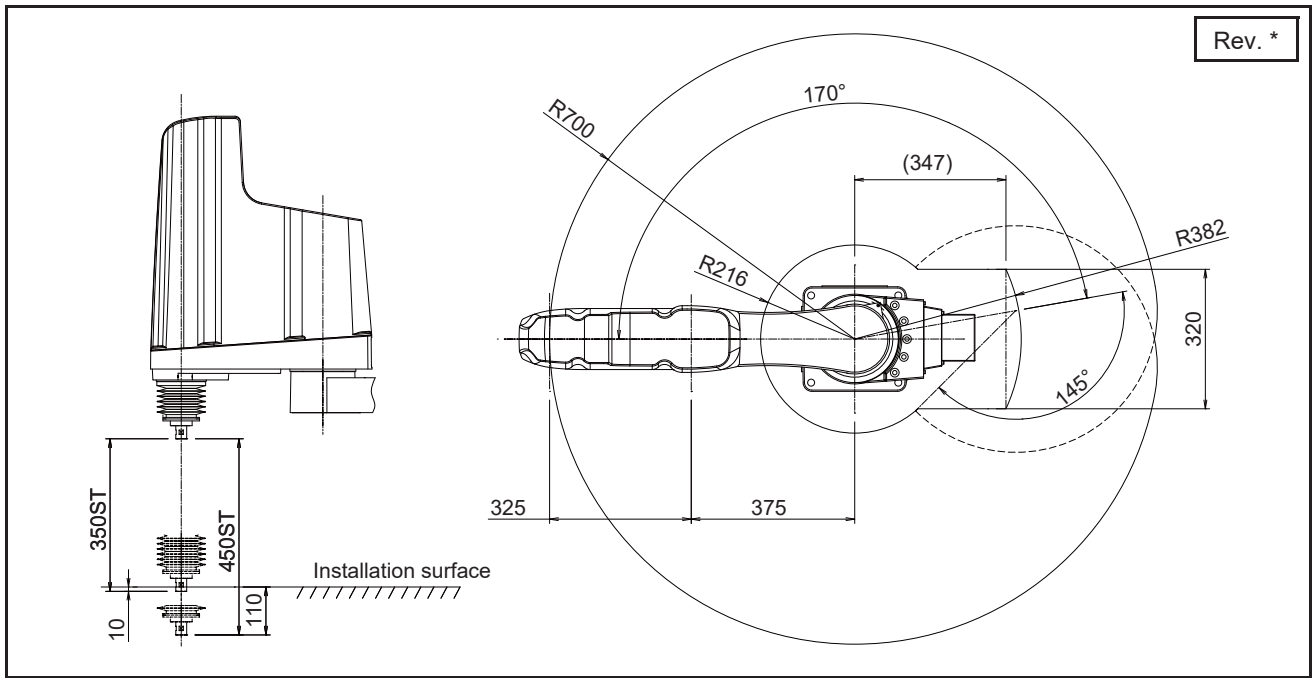

Fig.: Operating range diagram of RH-12FRH70xxC/M

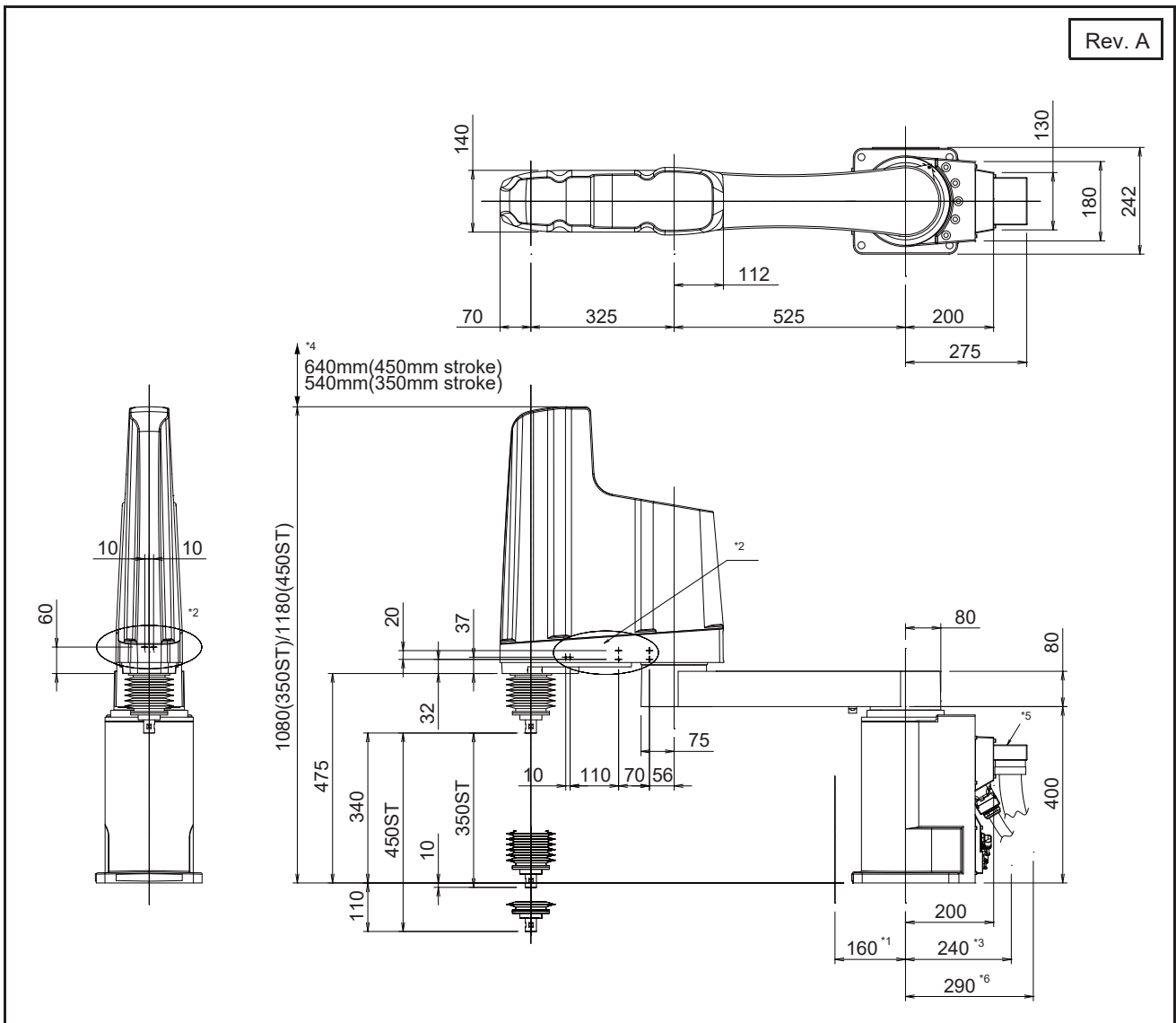

Fig.: Outside dimensions of RH-12FRH85xxC/M

- *1 Indicates the space necessary to replace the battery.
- *2 Indicates the screw holes for fixing user wiring/piping. (Refer to Fig.: Location of screw holes for fixing wiring/piping (RH-12FRH/20FRH series))
- *3 The distance to the minimum bendable radius of the machine cable.
- *4 Space required to install/remove the cover.
- *5 This duct ($\phi 50$ / total length: 2m) is provided on robots with clean specifications. Be careful for the hand etc. not to interfere and arrange the duct.
- *6 Indicates the space required to connect the machine cable.

Note) Refer to Fig.: Mechanical interface and Installation surface of RH-12FRH series for the mechanical interface section and installation base section dimensions.

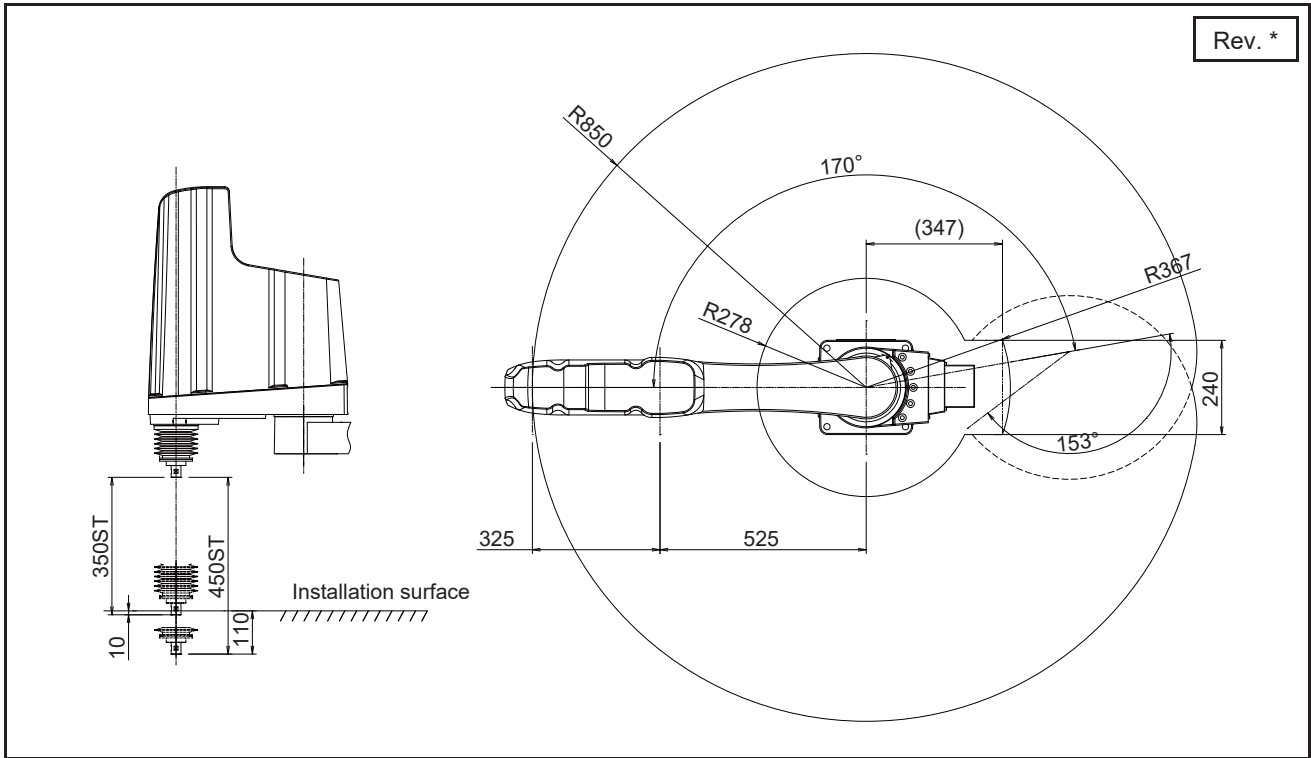

Fig.: Operating range diagram of RH-12FRH85xxC/M

Outside dimensions • Operating range diagram (RH-20FRH series)

Standard Specification

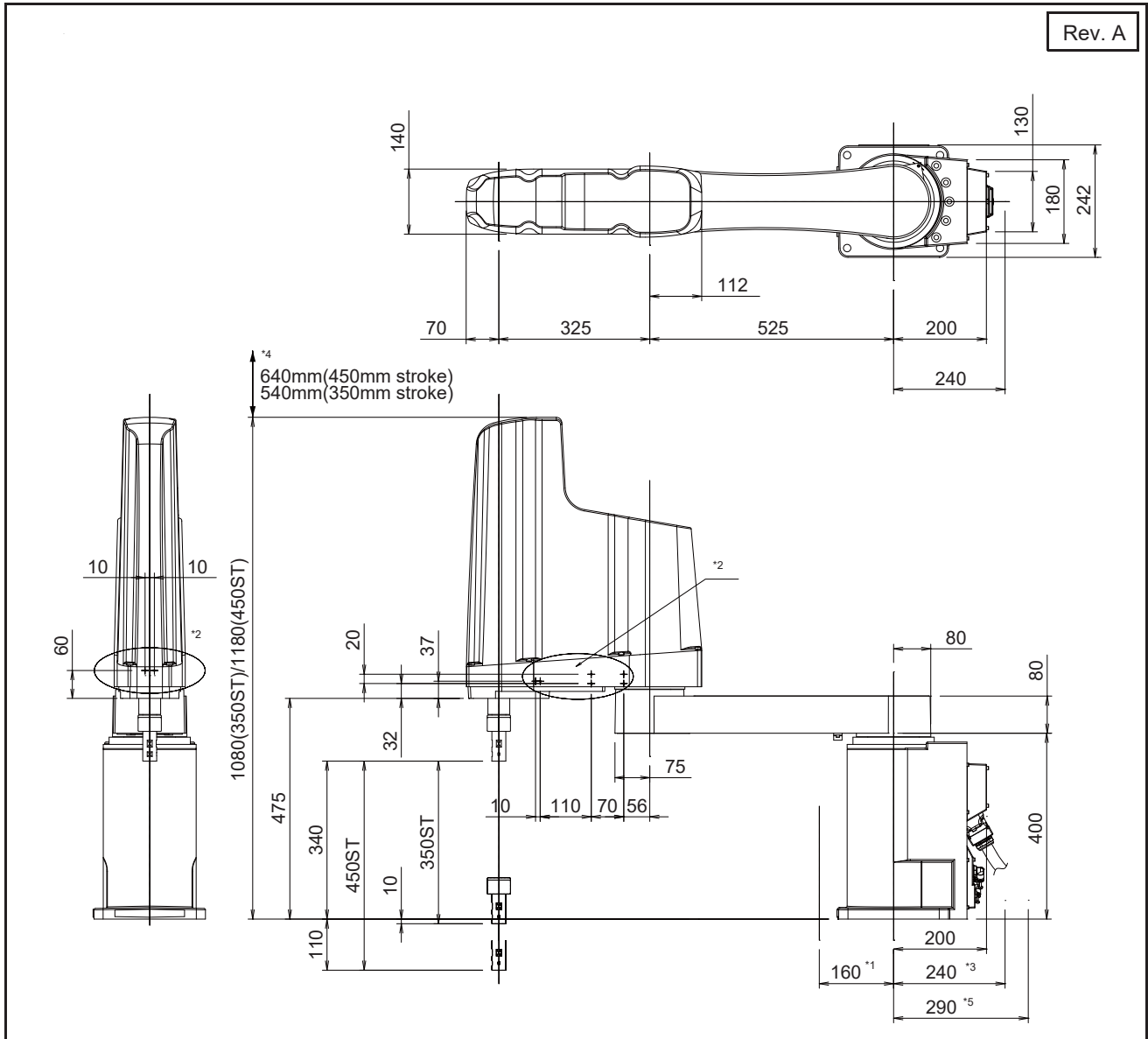

Fig.: Outside dimensions of RH-20FRH85xx

*1 Indicates the space necessary to replace the battery.

*2 Indicates the screw holes for fixing user wiring/piping. (Refer to Fig.: Location of screw holes for fixing wiring/piping (RH-12FRH/20FRH series))

*3 The distance to the minimum bendable radius of the machine cable.

*4 Space required to install/remove the cover.

*5 Indicates the space required to connect the machine cable.

Note) Refer to Fig.: Mechanical interface and Installation surface of RH-20FRH series for the mechanical interface section and installation base section dimensions.

Rev. *

350ST
450ST
10
110
Installation surface

R850
170°
R278
153°
325
525

2

Fig.: Operating range diagram of RH-20FRH85xx

2 Robot arm
2.4 Outside dimensions • Operating range diagram

121

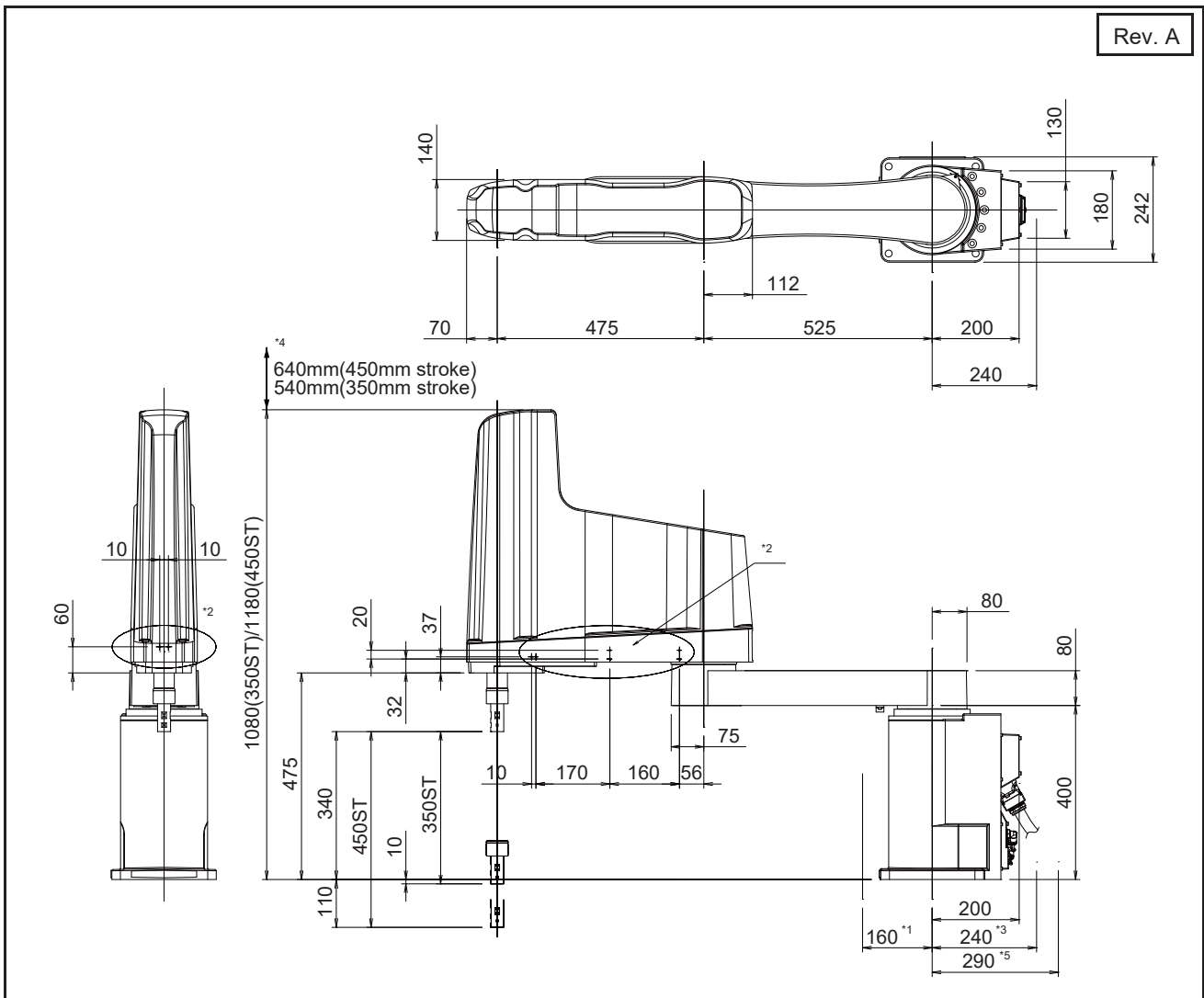

Fig.: Outside dimensions of RH-20FRH100xx

- *1 Indicates the space necessary to replace the battery.
- *2 Indicates the screw holes for fixing user wiring/piping. (Refer to Fig.: Location of screw holes for fixing wiring/piping (RH-12FRH/20FRH series))
- *3 The distance to the minimum bendable radius of the machine cable.
- *4 Space required to install/remove the cover.
- *5 Indicates the space required to connect the machine cable.

Note) Refer to Fig.: Mechanical interface and Installation surface of RH-20FRH series for the mechanical interface section and installation base section dimensions.

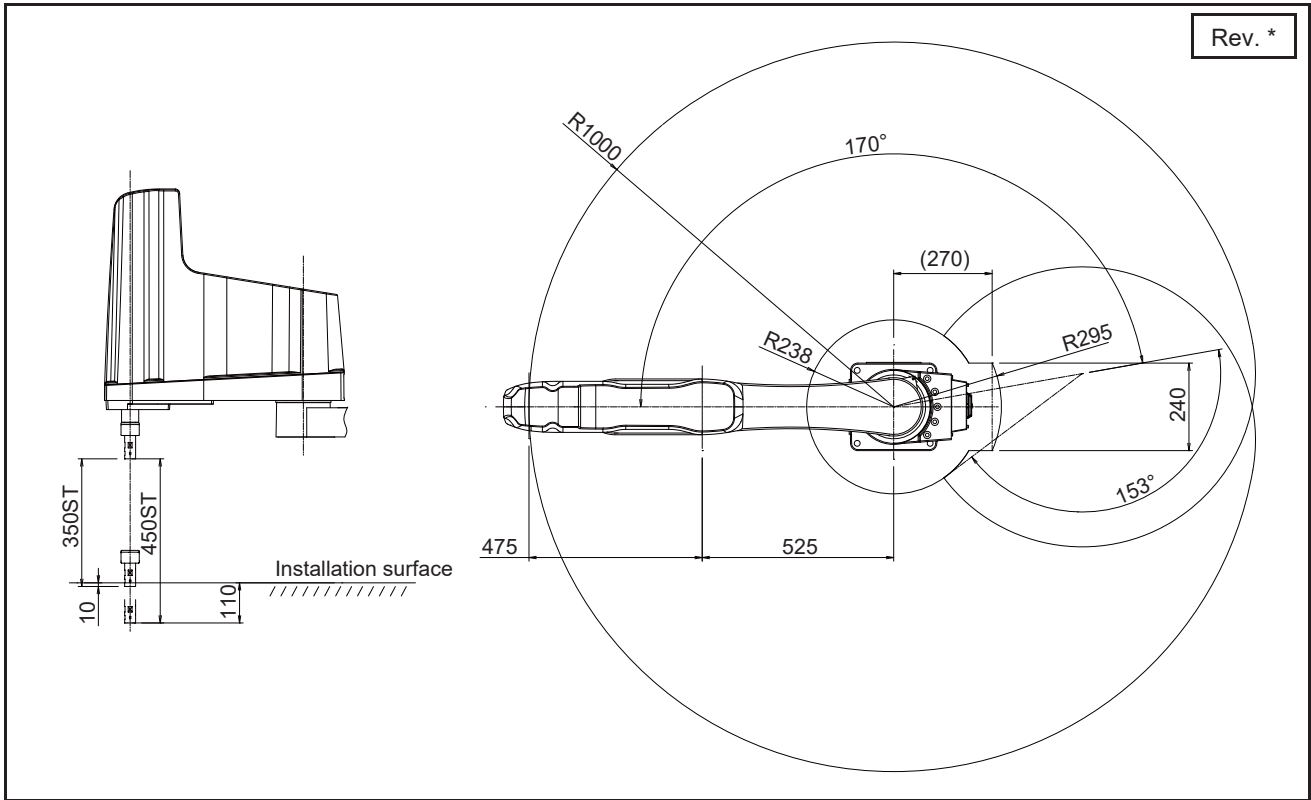

Fig.: Operating range diagram of RH-20FRH100xx

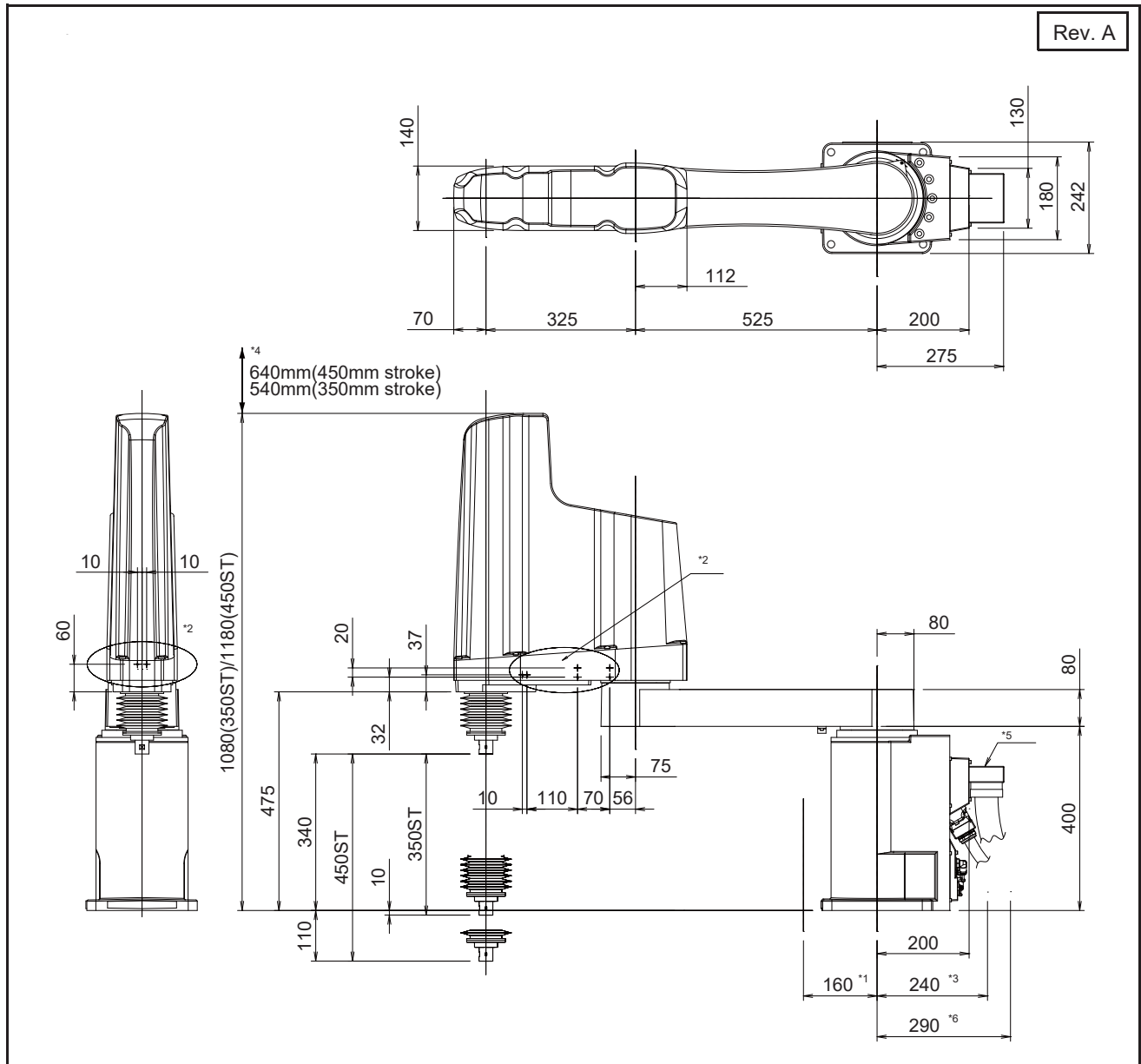

Fig.: Outside dimensions of RH-20FRH85xxC/M

- *1 Indicates the space necessary to replace the battery.
- *2 Indicates the screw holes for fixing user wiring/piping. (Refer to Fig.: Location of screw holes for fixing wiring/piping (RH-12FRH/20FRH series))
- *3 The distance to the minimum bendable radius of the machine cable.
- *4 Space required to install/remove the cover.
- *5 This duct ($\phi 50$ / total length: 2m) is provided on robots with clean specifications. Be careful for the hand etc. not to interfere and arrange the duct.
- *6 Indicates the space required to connect the machine cable.

Note) Refer to Fig.: Mechanical interface and Installation surface of RH-20FRH series for the mechanical interface section and installation base section dimensions.

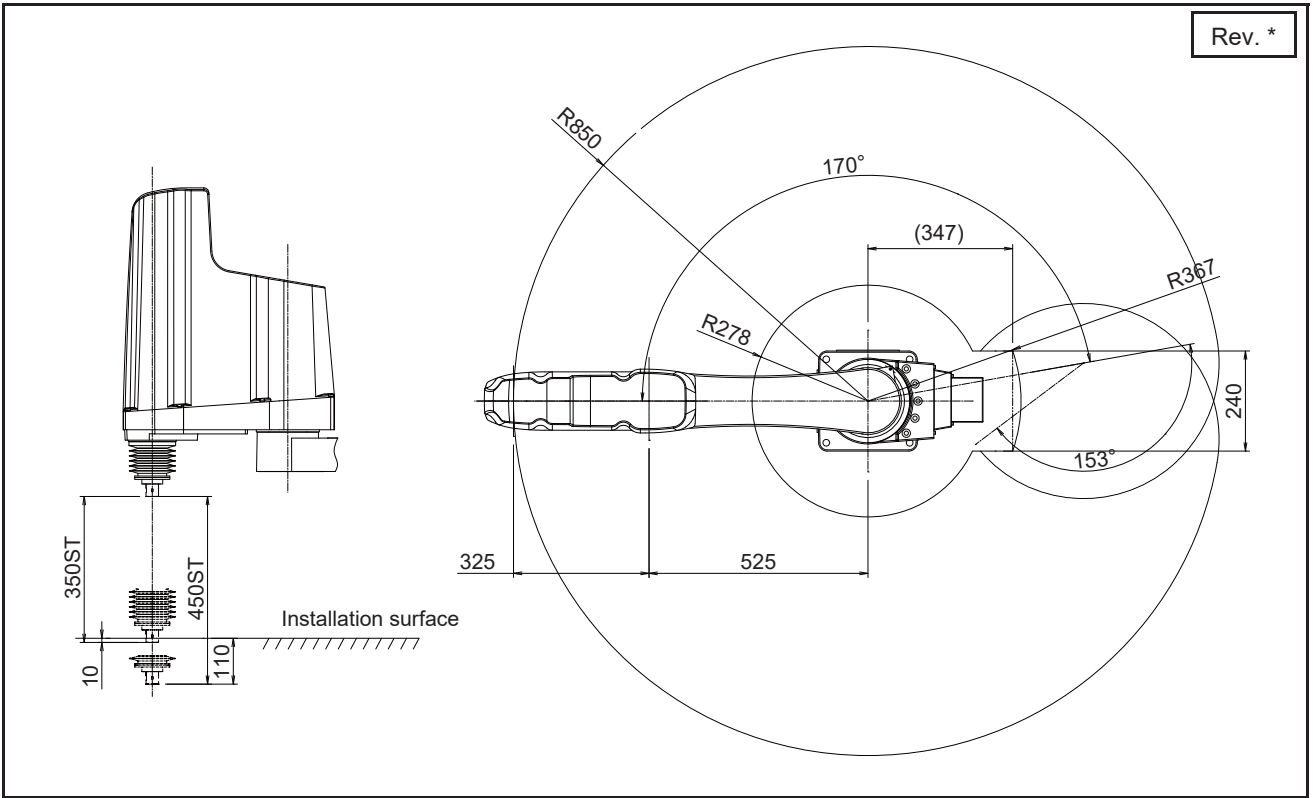

Fig.: Operating range diagram of RH-20FRH85xxC/M

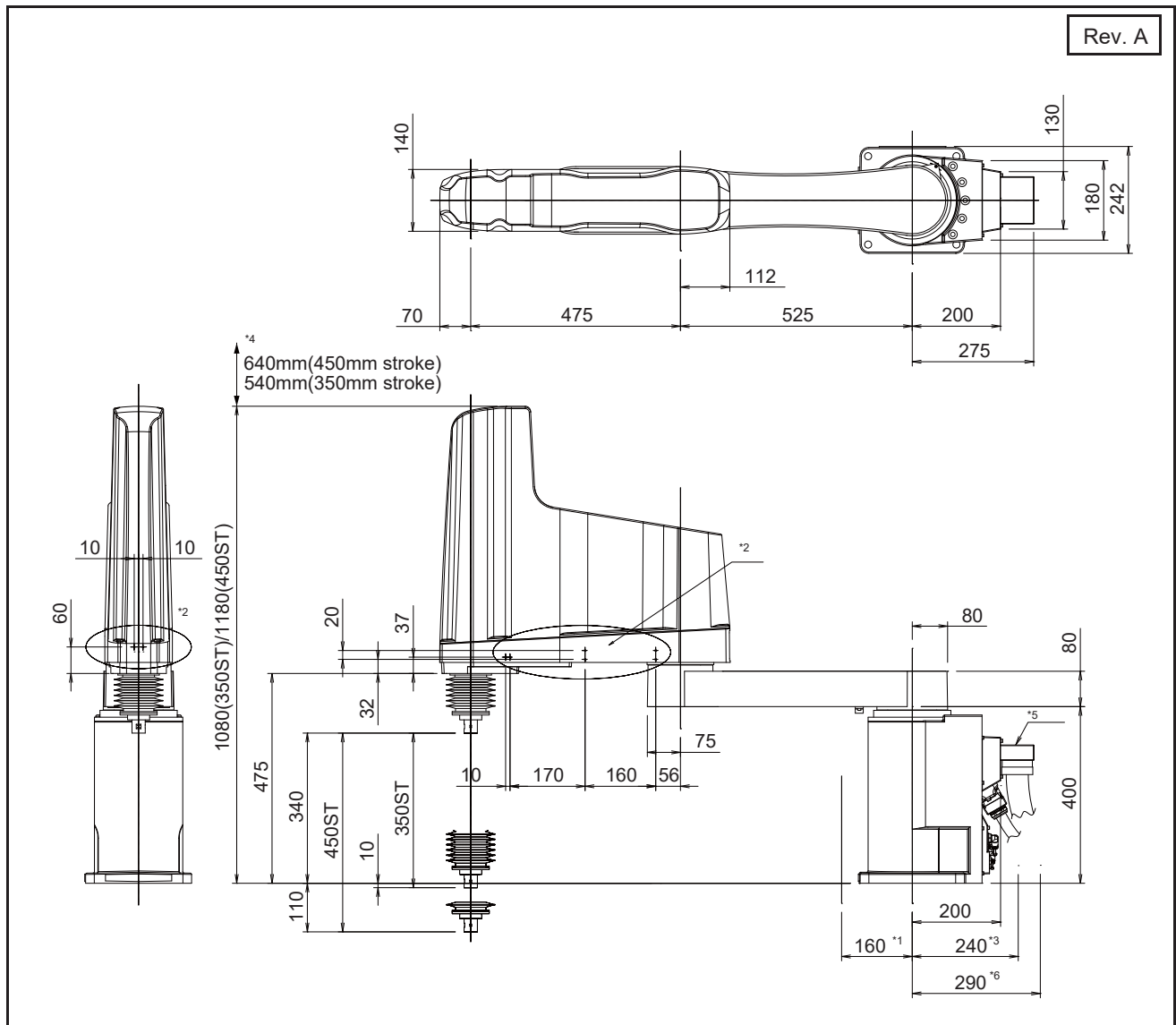

Fig.: Outside dimensions of RH-20FRH100xxC/M

- *1 Indicates the space necessary to replace the battery.
- *2 Indicates screw holes for fixing user wiring/piping. (Refer to Fig.: Location of screw holes for fixing wiring/piping (RH-12FRH/20FRH series))
- *3 The distance to the minimum bendable radius of the machine cable.
- *4 Space required to install/remove the cover.
- *5 The duct ($\phi 50$, length: 2m) attached to the clean specification. Be careful for the hand etc. not to interfere and arrange the duct.
- *6 Indicates the space required to connect the machine cable.

Note) Refer to Fig.: Mechanical interface and Installation surface of RH-20FRH series for the mechanical interface section and installation base section dimensions.

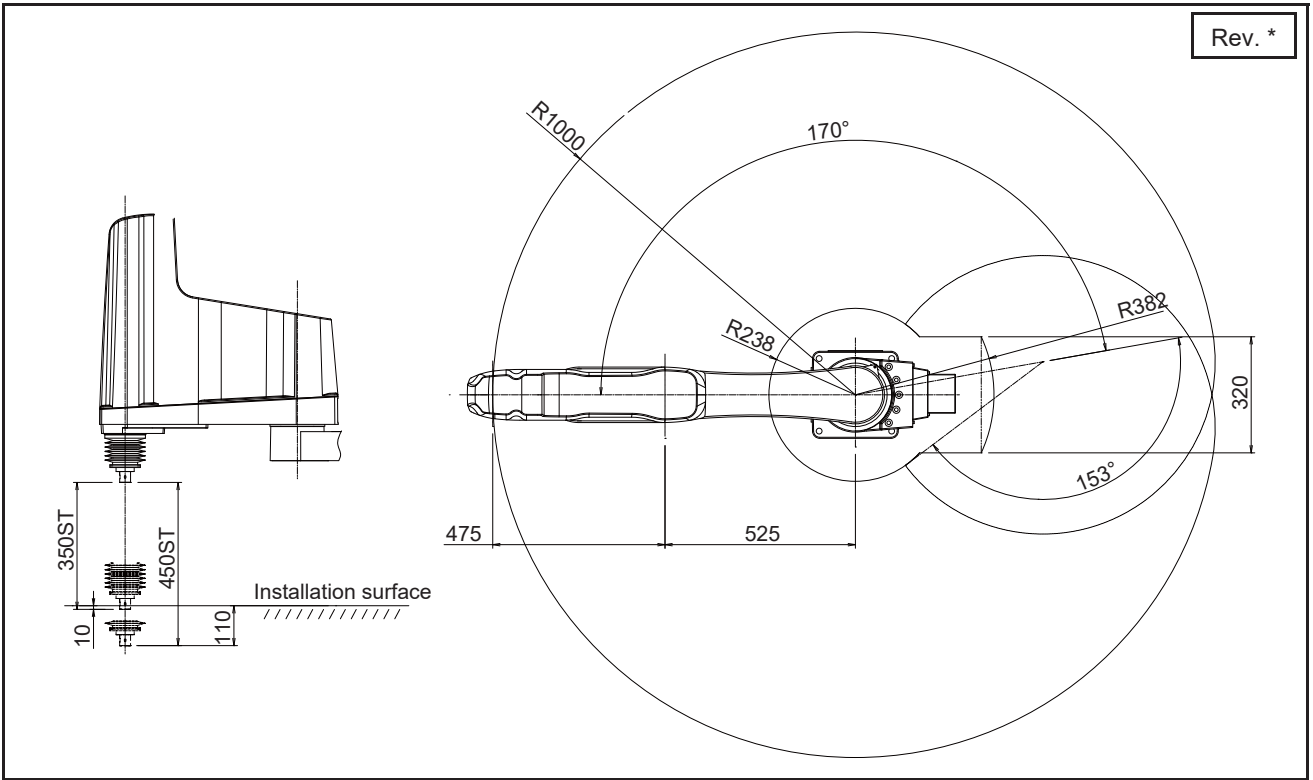

Fig.: Operating range diagram of RH-20FRH100xxC/M

Outside dimensions • Operating range diagram of RH-3FRHR series

Standard Specification

Rev. *

Notice

1. The outside dimensions exclude projecting parts.
2. The posture of the figure are J1=0 degree, J2=+180 degree, J3=-583mm, and J4=0 degree.

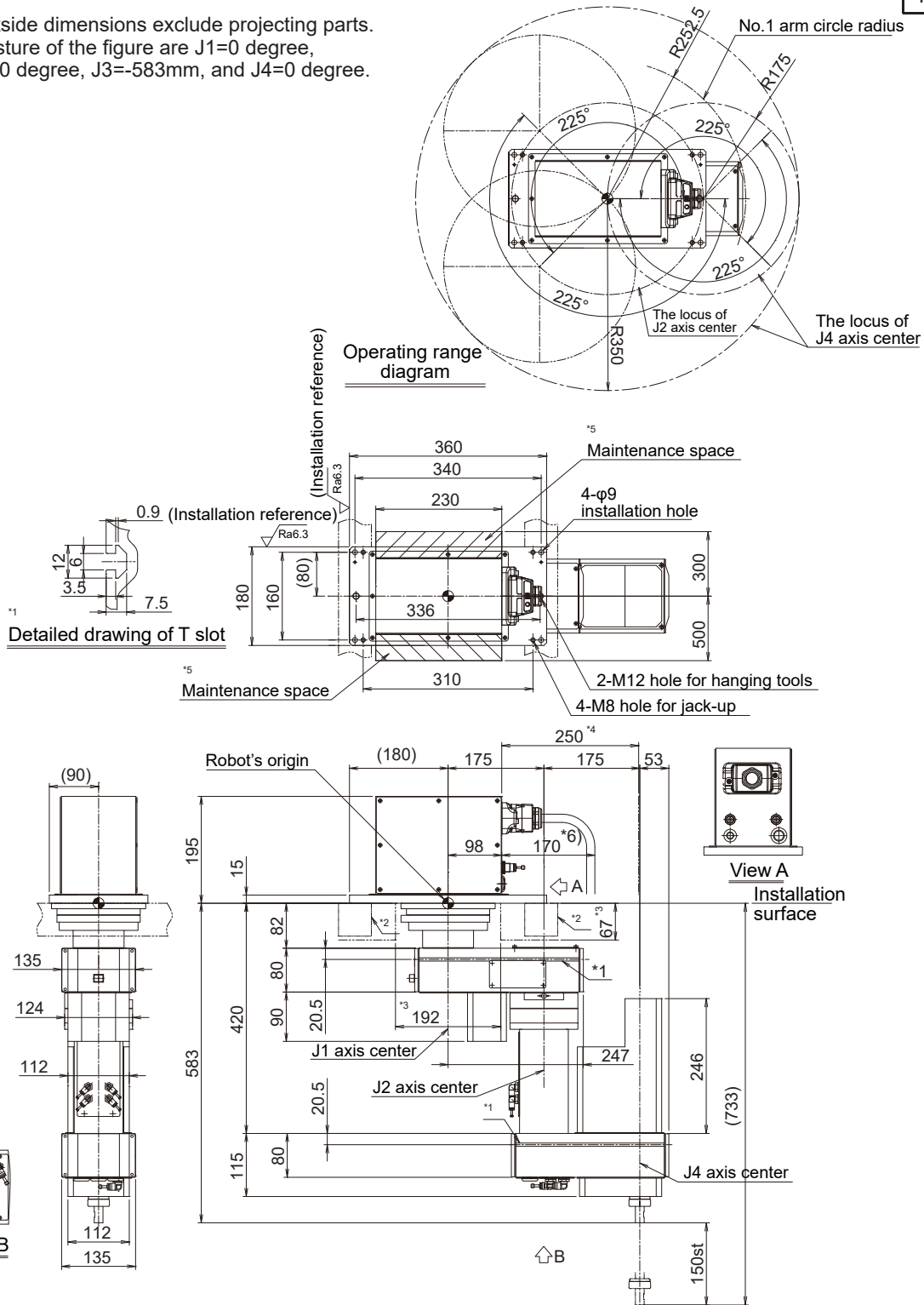



Fig.: Outside dimensions, Operating range diagram of RH-3FRHR series (Standard specification)

- *1 The T slot for piping, wiring, and solenoid valve installation. (Attach the M5 nut)
- *2 The installation stage (customer arrangements).
- *3 Is allowance stage dimensions
- *4 The space necessary for connection of the machine cable
- *5 The maintenance space necessary for battery replacement etc.
- *6 The distance to the minimum bendable radius of the machine cable.

Note1) Refer to  Fig.: Mechanical interface and Installation surface of RH-3FRHR series (Standard specification for the mechanical interface section and installation base section dimensions.

Note2) Use of the optional solenoid valve set. The solenoid valve set installed at the side on the No.2 arm. (*1) mark) Take care at layout design.

Note3) The position on the vertical extension of the "robot origin" becomes the singular point. Positioning and passage to this position with linear interpolation movement cannot be performed. Take care at layout design.

Clean/waterproof Specification

Rev. *

Notice

1. The outside dimensions exclude projecting parts.
2. The posture of the figure are J1=0 degree, J2=+180 degree, J3=-583mm, and J4=0 degree.

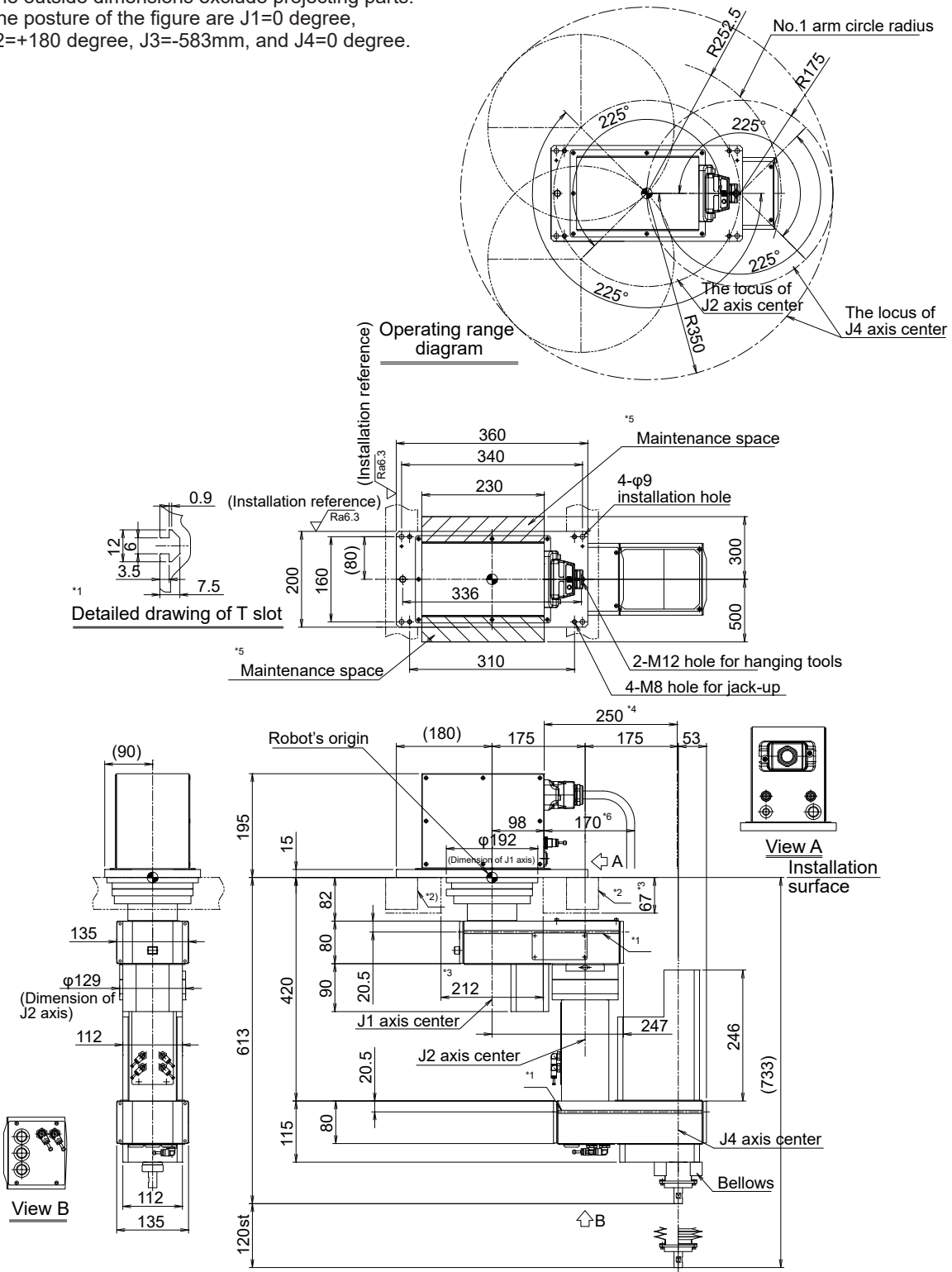



Fig.: Outside dimensions, Operating range diagram of RH-3FRHR series (Clean/waterproof specification)

- *1 The T slot for piping, wiring, and solenoid valve installation. (Attach the M5 nut)
- *2 The installation stage (customer arrangements).
- *3 Is allowance stage dimensions
- *4 The space necessary for connection of the machine cable
- *5 The maintenance space necessary for battery replacement etc.
- *6 The distance to the minimum bendable radius of the machine cable.

Note1) Refer to  Fig.: Mechanical interface and Installation surface of RH-3FRHR series (Clean/waterproof specification) for the mechanical interface section and installation base section dimensions.

Note2) Use of the optional solenoid valve set. The solenoid valve set installed at the side on the No.2 arm. (*1) mark) Take care at layout design.

Note3) The position on the vertical extension of the "robot origin" becomes the singular point. Positioning and passage to this position with linear interpolation movement cannot be performed. Take care at layout design.

Mechanical interface and Installation surface

RH-3FRH series

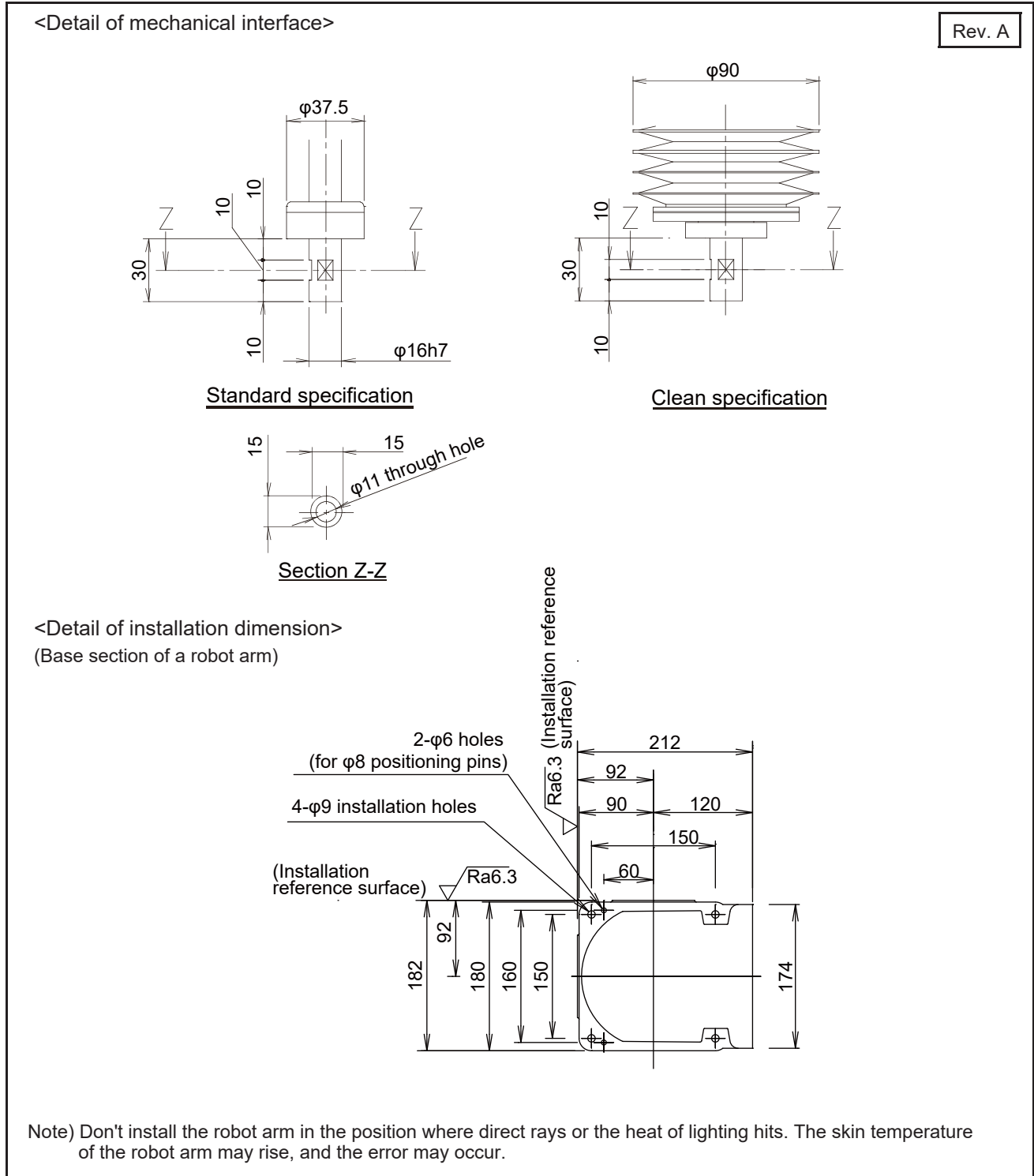
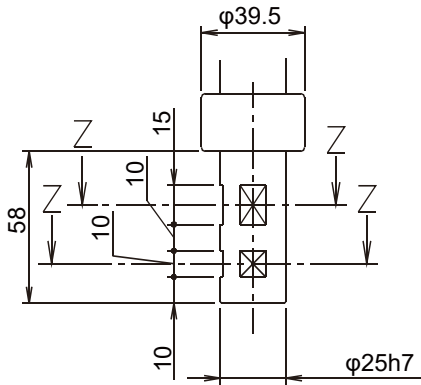
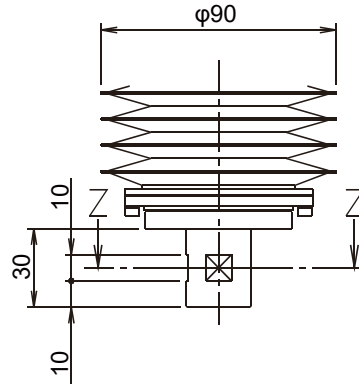

Fig.: Mechanical interface and Installation surface (RH-3FRH series)

<Detail of mechanical interface>



Standard specification



Clean and oil mist specification

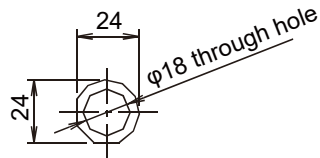

Section Z-Z

<Detail of installation dimension>

(Base section of a robot arm)

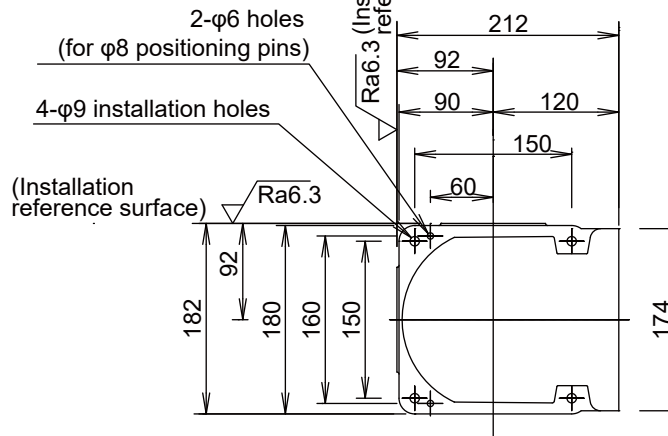

Note) Don't install the robot arm in the position where direct rays or the heat of lighting hits. The skin temperature of the robot arm may rise, and the error may occur.

Fig.: Mechanical interface and Installation surface (RH-6FRH series)

<Detail of mechanical interface>

Standard specification

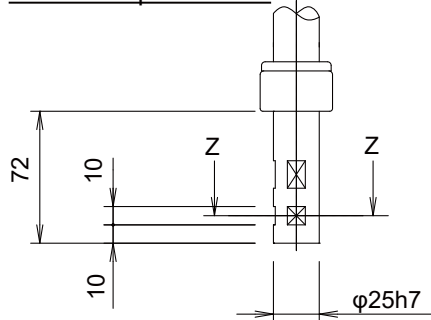

Clean/oil mist specification

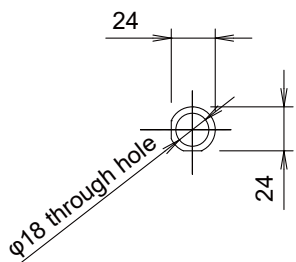
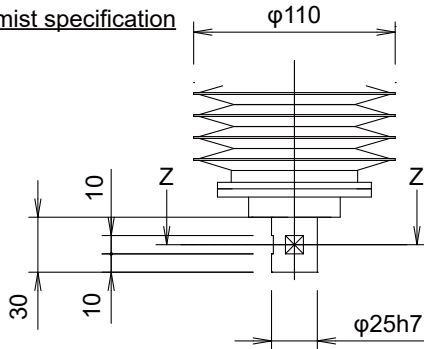

Section Z-Z

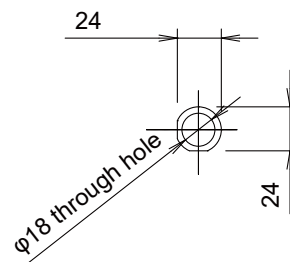

Section Z-Z

<Detail of installation dimension>

(Base section of a robot arm)

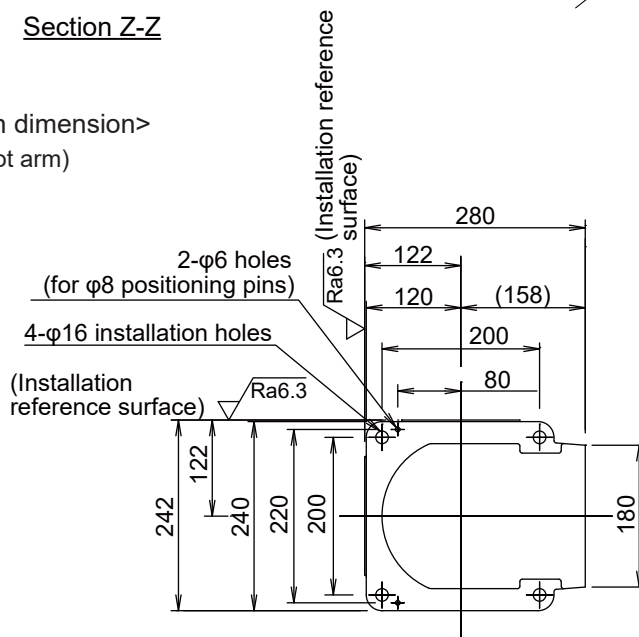

Note) Don't install the robot arm in the position where direct rays or the heat of lighting hits. The skin temperature of the robot arm may rise, and the error may occur.

Fig.: Mechanical interface and Installation surface of RH-12FRH series

<Detail of mechanical interface>

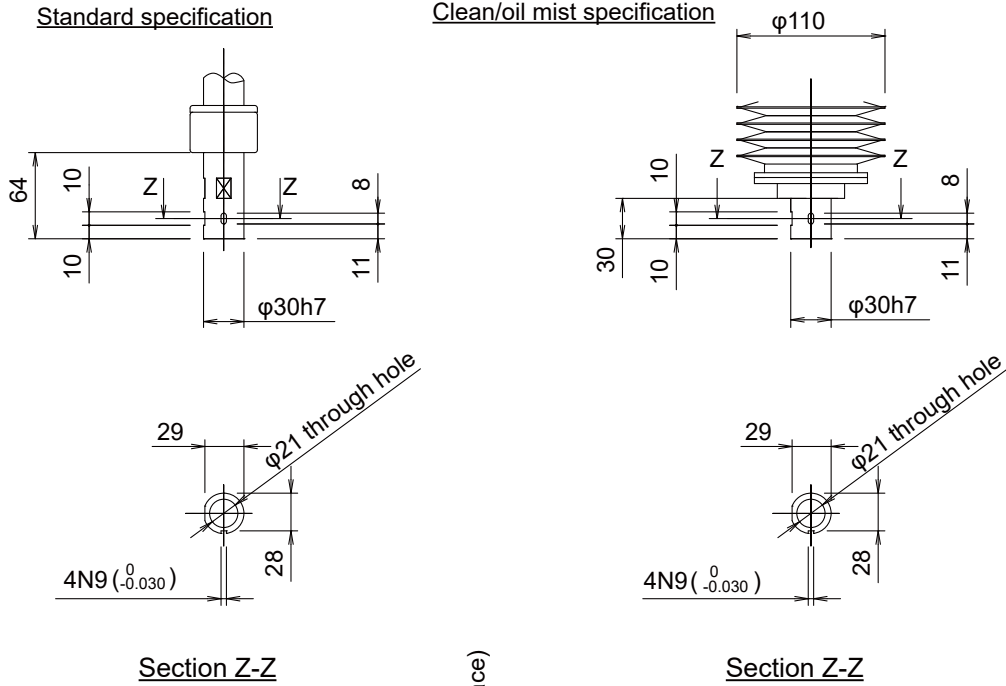

<Detail of installation dimension>
(Base section of a robot arm)

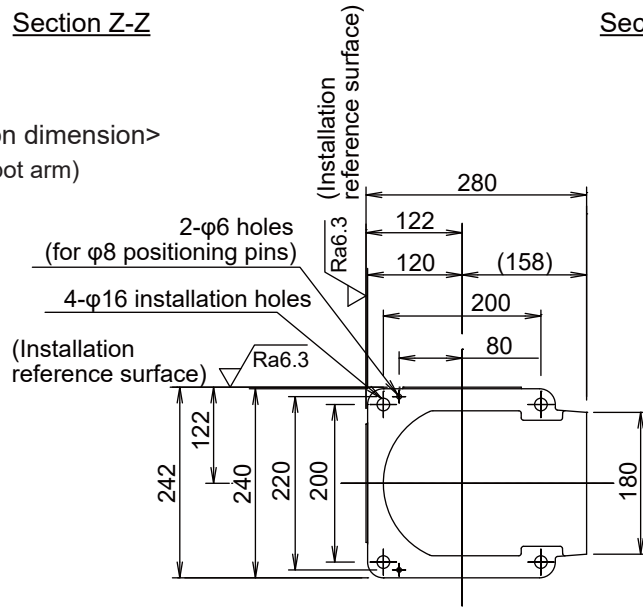

Note) Don't install the robot arm in the position where direct rays or the heat of lighting hits. The skin temperature of the robot arm may rise, and the error may occur.

Fig.: Mechanical interface and Installation surface of RH-20FRH series

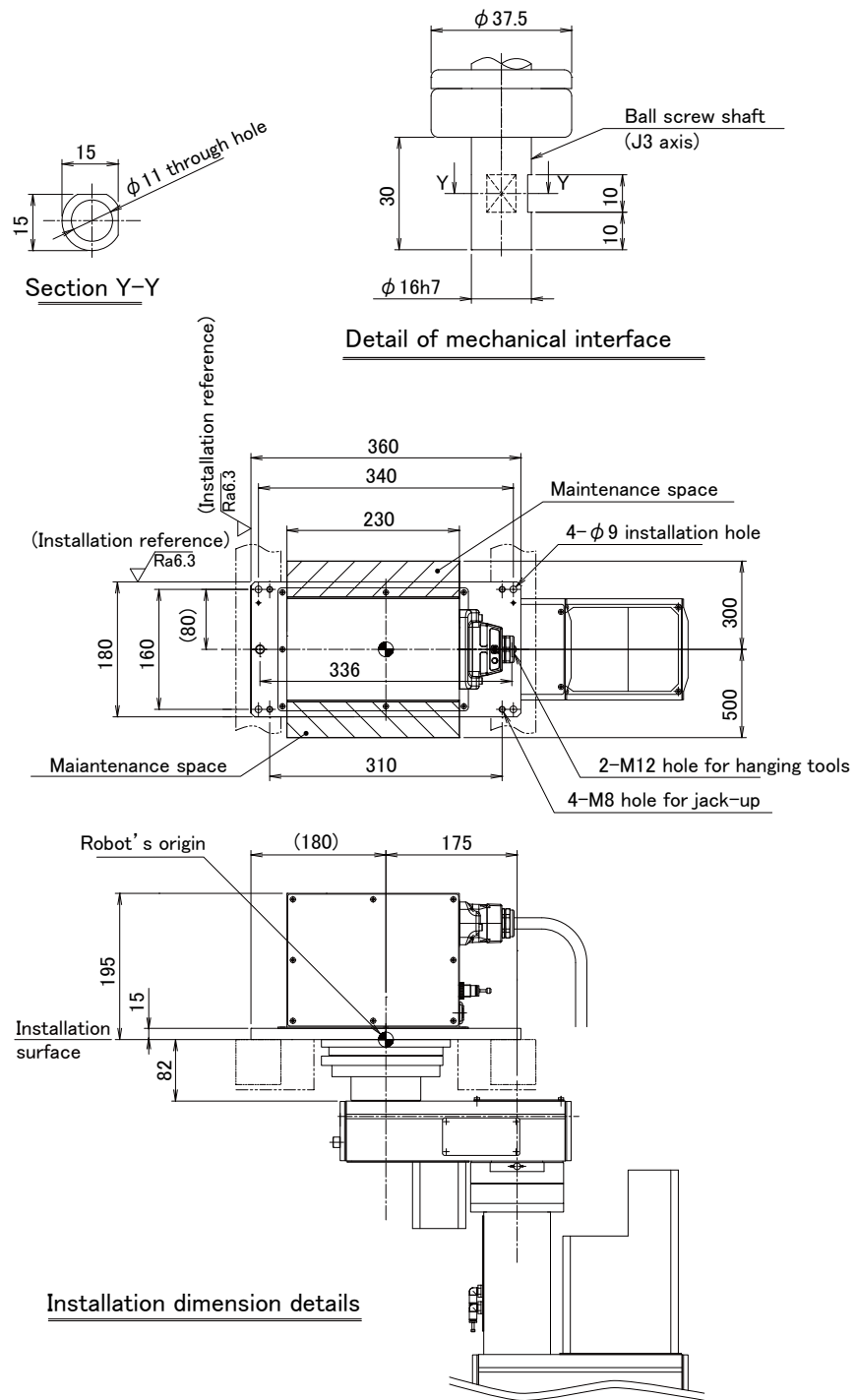

Fig.: Mechanical interface and Installation surface of RH-3FRHR series (Standard specification)

⚠ CAUTION

Don't give a shock to the ball screw shaft at the time of hand installation. Especially don't strike the shaft end by hammer etc. The ball screw shaft may be damaged.

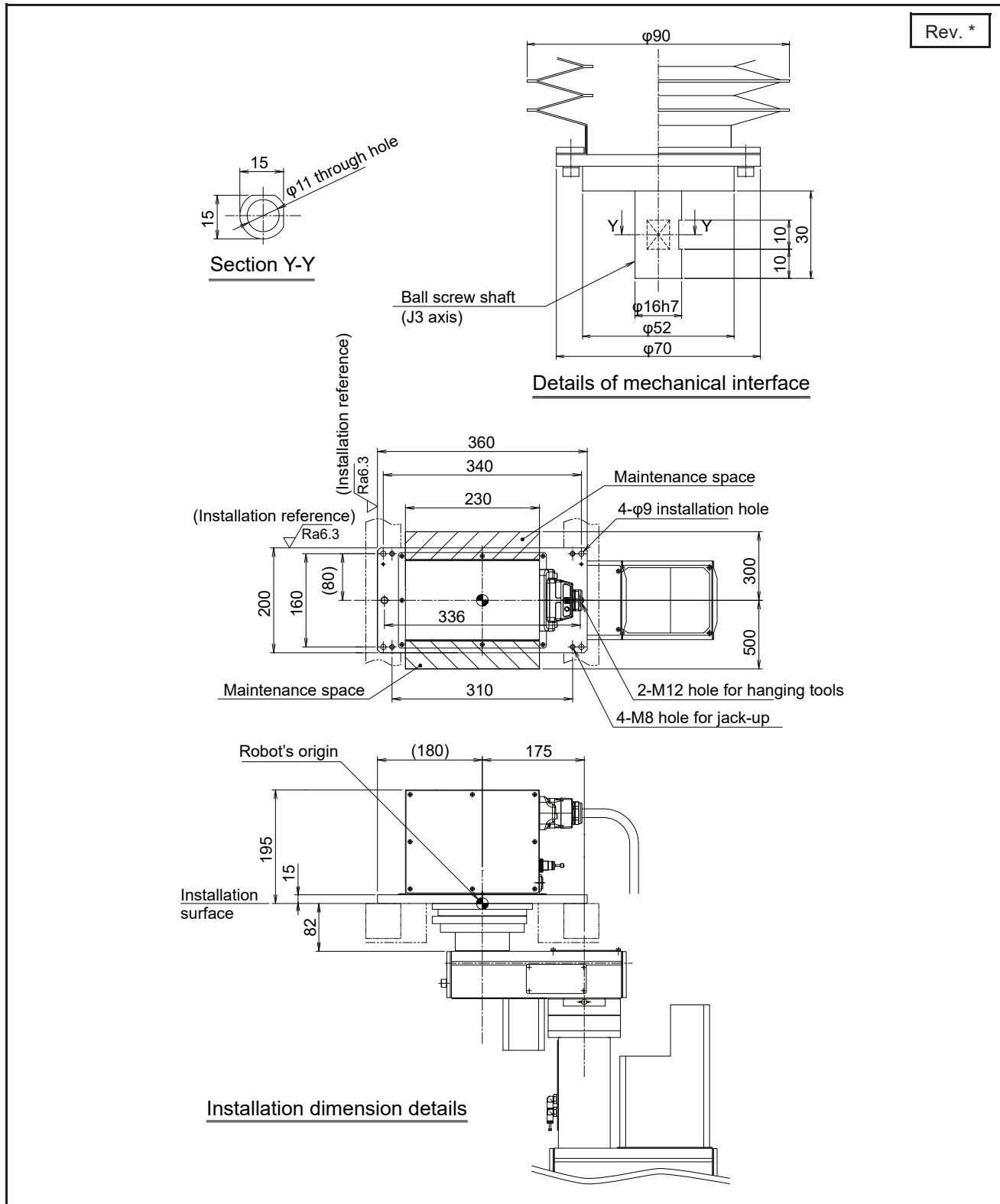
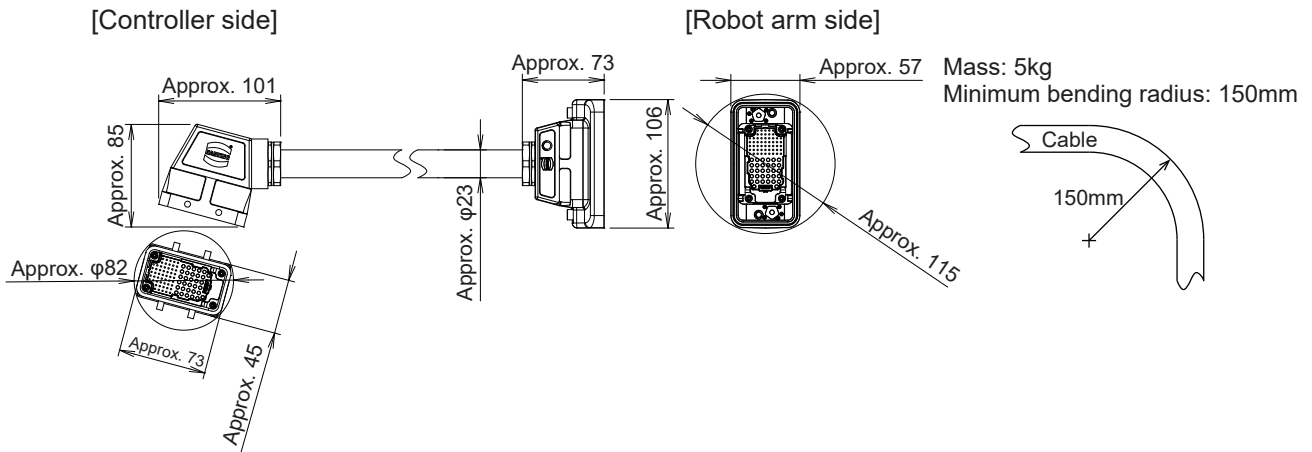



Fig.: Mechanical interface and Installation surface of RH-3FRHR series (Clean/waterproof specification)

CAUTION

Don't give a shock to the ball screw shaft at the time of hand installation. Especially don't strike the shaft end by hammer etc. The ball screw shaft may be damaged.

Outside dimensions of machine cables



Note) If using an optional machine cable (replacement), refer to  Page 159 Machine cable (replacement)

2.5 Tooling

Wiring and piping for hand

Shows the wiring and piping configuration for a hand.

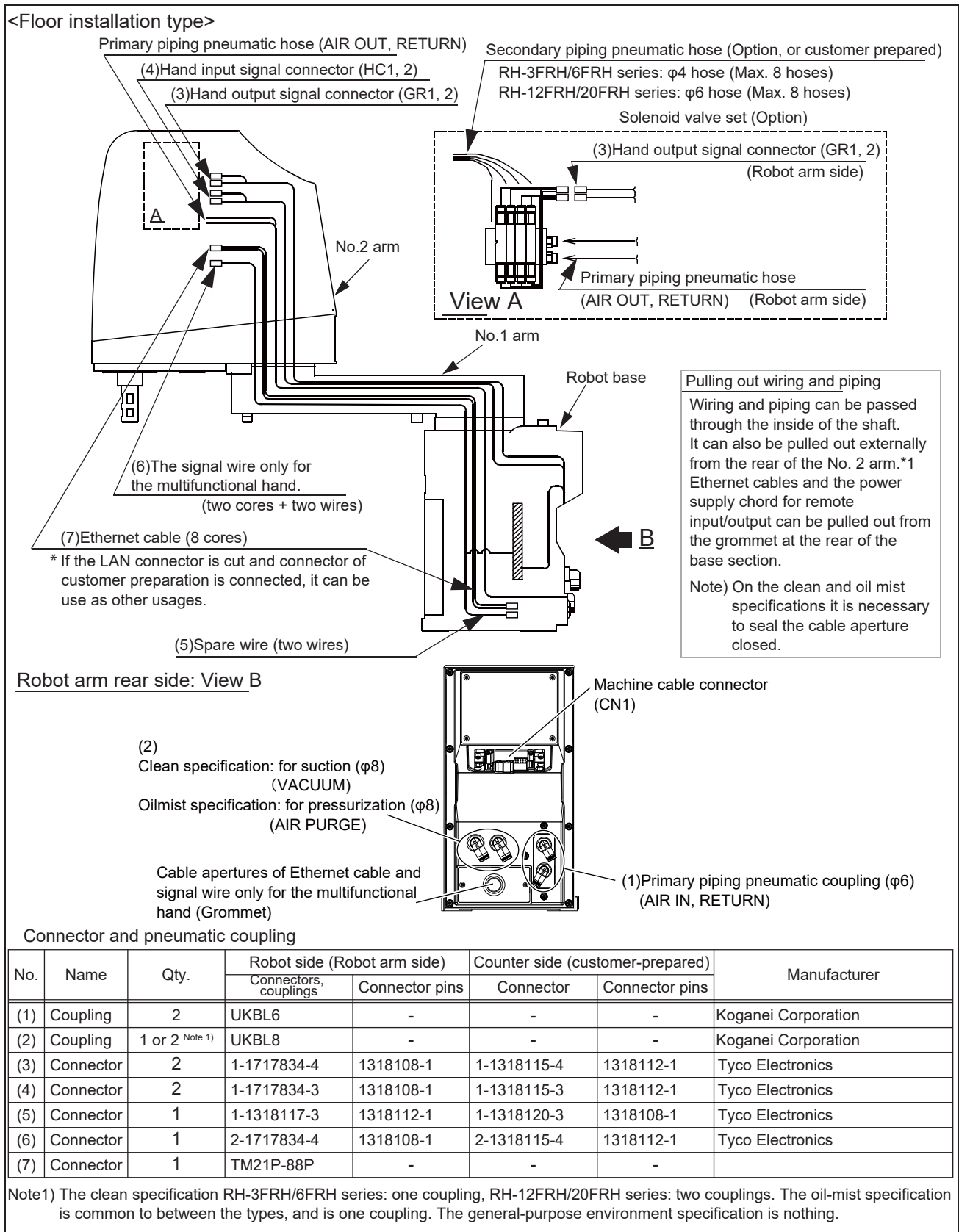

Fig.: Wiring and piping for hand (Floor installation type)

*1 Use the external wiring and piping box.
Refer to the following page:
☞ Page 182 External Wiring/Piping box

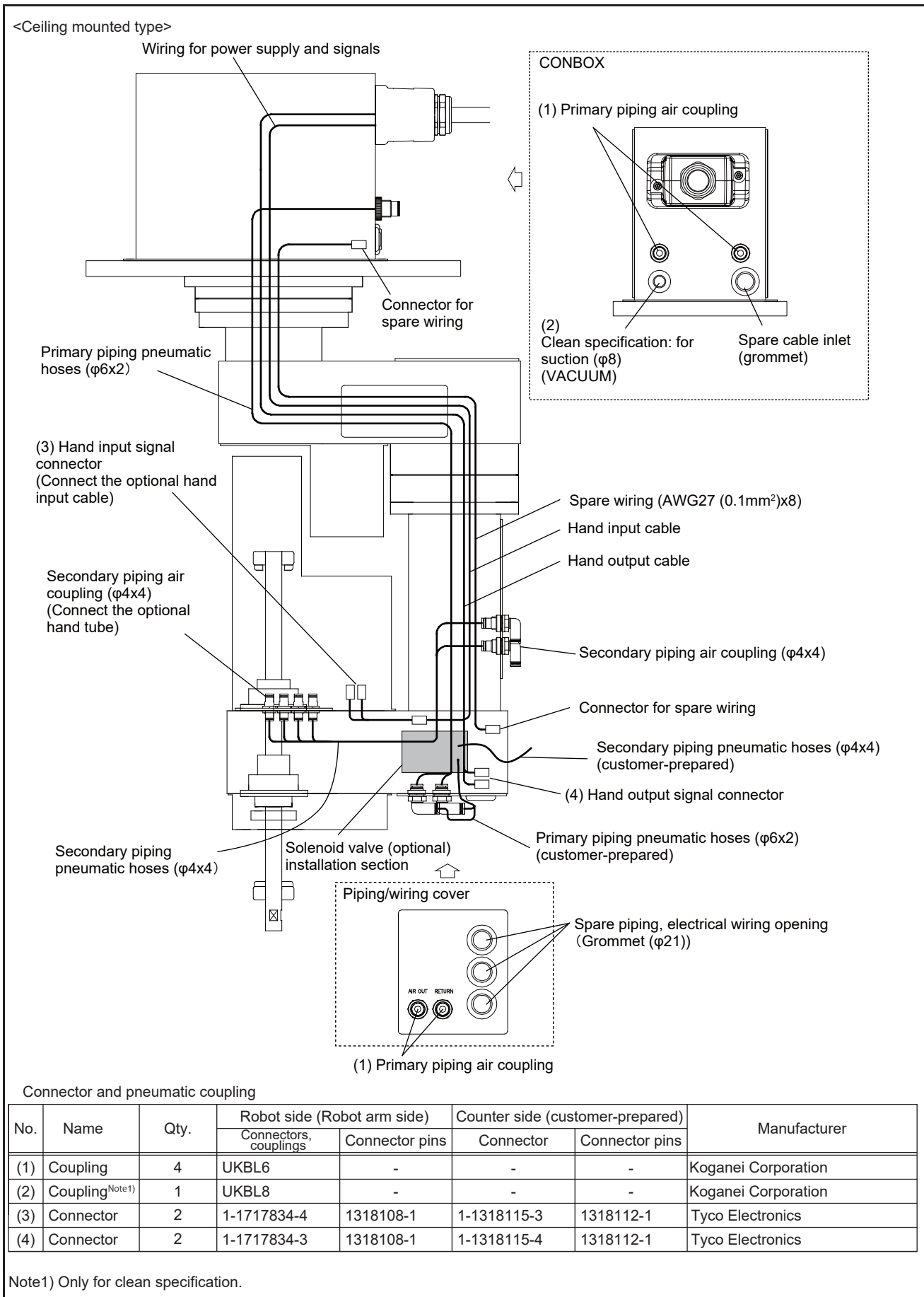



Fig.: Wiring and piping for hand (Ceiling mounted type)

Internal air piping

Floor installation type

■Standard/oilmist specifications

- 1) The robot has two $\phi 6$ urethane hoses from the pneumatic entrance on the base section to the No.2 arm. One hose is the primary piping for the pneumatic equipment, and the other pipe is used for air exhaust.
- 2) The pneumatic inlet in the base section has a $\phi 6$ pneumatic coupling bridge.
- 3) The solenoid valve set (optional) can be installed to the side on No.2 arm.
- 4) Refer to  Page 164 Solenoid valve set for details on the electronic valve set (optional).
- 5) Protection performance can be improved by pressurizing the inside of the robot arm. Since the joint (AIR PURGE) of $\phi 8$ is prepared at the rear of the base section, please supply the dry air for pressurization from this joint. Refer to  Page 77 Protection specifications for the details of dry air.

■Clean Specifications

- 1) The primary piping is the same piping as the standard type.
- 2) With the clean specification, a $\phi 8$ coupling is provided in the base section for suction inside the machine. For use, connect it to the suction port of the vacuum pump or the coupling on the "VACUUM" side of the vacuum generating valve. Moreover, to clean the exhaust from the vacuum pump or vacuum generator, use the exhaust filter (prepared by the customer).
- 3) Refer to  Page 80 Clean specifications for details of the vacuum for suction.
- 4) Supply clean air to the vacuum generator.

Ceiling mounted type

■Standard/waterproof specifications

- 1) The robot has two $\phi 6$ urethane hoses from the pneumatic entrance on the base section to the No.2 arm. One hose is the primary piping for the pneumatic equipment, and the other pipe is used for air exhaust.
- 2) The pneumatic inlet in the base section has a $\phi 6$ pneumatic coupling bridge.
- 3) The solenoid valve set (optional) can be installed to the side on No.2 arm.
- 4) Refer to  Page 164 Solenoid valve set for details on the electronic valve set (optional).
- 5) The four air hoses ($\phi 4$) are piped as the secondary from the No.2 arm back end to near the shaft.

■Clean specifications

- 1) The primary piping is the same piping as the standard type.
- 2) With the clean specification, a $\phi 8$ coupling is provided in the base section for suction inside the machine. For use, connect it to the suction port of the vacuum pump or the coupling on the "VACUUM" side of the vacuum generating valve. Moreover, to clean the exhaust from the vacuum pump or vacuum generator, use the exhaust filter (prepared by the customer).
- 3) Refer to  Page 80 Clean specifications for details of the vacuum for suction.
- 4) Supply clean air to the vacuum generator.

Internal wiring for the hand output cable

Floor installation type

The hand output primary cable extends from the connector of the base section to the back side of the No.2 arm. (AWG#24(0.2mm²): 10 cables) The cable terminals have connector bridges for eight hand outputs. The connector names are GR1 and GR2.

To pull the wiring out of the arm, following separate options are required.

Option	Model	Remarks
Hand output cable	1F-GR60S-01	
External wiring and piping box	1F-UT-BOX	RH-3FRH/6FRH series
	1F-UT-BOX-01	RH-12FRH/20FRH series

Ceiling mounted type

The hand output primary cable extends from the connector of the base section to the back side of the No.2 arm. (AWG#24(0.2mm²)) The cable terminals have connector bridges for eight hand outputs. The connector names are GR1 and GR2. The separate cable (optional "hand output cable 1S-GR35S-02") is necessary, to extend the cable to outside of the arm.

Internal wiring for the hand input cable

Floor installation type

1) The hand input cable extends from the connector of the base section to the No.2 arm. (AWG#24(0.2mm²): 10 cables) The cable terminals have connector bridges for eight hand inputs. The connector names are HC1 and HC2.

2) The hand check signal of the pneumatic hand is input by connecting this connector.

To extend the wiring to the outside of the arm, following separate options are required.

Option	Model	Remarks
Hand input cable	1F-HC35C-01	RH-3FRH/6FRH series
	1F-HC35C-02	RH-12FRH/20FRH series
External wiring and piping box	1F-UT-BOX	RH-3FRH/6FRH series
	1F-UT-BOX-01	RH-12FRH/20FRH series

Ceiling mounted type

1) The hand input cable extends from the connector PCB of the base section to the No.2 arm. (AWG#24(0.2mm²)) The cable terminals have connector bridges for four hand inputs. The connector names are HC1 and HC2.

2) The hand check signal of the pneumatic hand is input by connecting this connector.

Ethernet cable (For RH-3FRH/6FRH/12FRH/20FRH series)

Ethernet cables are installed from the RH-3FRH/6FRH/12FRH/20FRH series robot's base section up to the No. 2 arm section, and can be used. Similar to on our previous models, these cables can also be used for backup wiring. For further details please refer to  RH-FRH Series INSTRUCTION MANUAL ROBOT ARM SETUP & MAINTENANCE (BFP-A3472).

Example of use for backup wiring.

- When connecting previously used tools to the robot
- Folding back the hand output cable when attaching the electromagnetic valve to the robot's exterior.
- When attaching 8 devices or more to the hand section such as sensors, (8 input and 8 output dedicated points are available for hand signals.). In this case connect the signals (of the sensors, etc.) to parallel input/output signals.

When shipped from the factory, both ends are LAN connectors.

When using it as backup wiring, cut the LAN connectors off and use with user supplied connectors.

When using it as backup wiring for data communication, the shield wire must be grounded. If the shield wire is not grounded, it may cause a communication abnormality by noise superposed on the cable.

Table: Ethernet cable specification

Item	Specification
Communication speed	100BASE-TX
Size	AWG #26 (0.13mm ²) x four pair (total eight cores)
Externality of insulator	Approx. 0.98 mm

* If connecting a PoE device to the Ethernet cable, use the device with PoE class 2 (6.49W max.) or less.

Spare Wiring (For FH-3FRHR series)

As spare wiring, four pairs of cab tire cables (AWG#27(0.1mm²), total is eight cores both) are preinstalled between the base section and the No.2 arm rear section in the RH-3FRHR series robot. Customer can utilize it. Refer to  RH-FRH Series INSTRUCTION MANUAL ROBOT ARM SETUP & MAINTENANCE (BFP-A3472) for details.

Both ends of the wire terminals are unprocessed. Use them under the following circumstances:

- For folding as the hand output cable when installing the solenoid valve in outside the robot.
- For when installing six or more hand I/O points for the sensor in the hand section

(Connects to the parallel I/O general purpose input.)

Reference) Pin assignment of the connector, and the matching connector

Pin assignment

Pin	Color
A1	Red
A2	Brown
A3	Green
A4	Black
B1	Orange
B2	White
B3	Yellow
B4	Blue

Robot side connector



Connection place	Connector	Contact	Maker
Base portion	2-1318115-4	-	Tyco Electronics
Fore arm portion	2-1717834-4	-	

Other party connector (recommendation)

Connection place	Connector	Contact	Maker
Base portion	2-1717834-4	1318108-1	Tyco Electronics
Fore arm portion	2-1318115-4	1318112-1	

About the Installation of Tooling Wiring and Piping (Examples of Wiring and Piping)

The customer is required to provide tooling wiring, piping and metal fixtures.

Screw holes are provided on the robot arm for the installation of tooling wiring, piping and metal fixtures. (Refer to the  Fig.: Location of screw holes for fixing wiring/piping (RH-6FRH series) to  Fig.: Location of screw holes for fixing wiring/piping (RH-3FRHR series).)

The length of wiring and piping and the installation position on the robot must be adjusted according to the work to be done by the robot. Please use the following example as reference.

Precautions

- A hand input cable and a hand curl cable are available as optional accessories for your convenience.
- After performing wiring and piping to the robot, operate the robot at low speed to make sure that each part does not interfere with the robot arm and the peripheral devices. Confirm that there is no interference also with bellows of the shaft section by clean specification and oil mist specification.
- Please be aware that dust may be generated from friction if wires and pipes come into contact with the robot arm when using it according to the clean specifications.
- If you install metal fixtures and a solenoid valve using the screw holes on the No.2 arm portion, add the mass of the metal fixtures and the solenoid valve to mass of a hand then set the HNDDAT parameter. Moreover, Fix the parts, such as a solenoid valve, firmly to prevent the parts getting shaky during operation of a robot.

RH-3FRH series

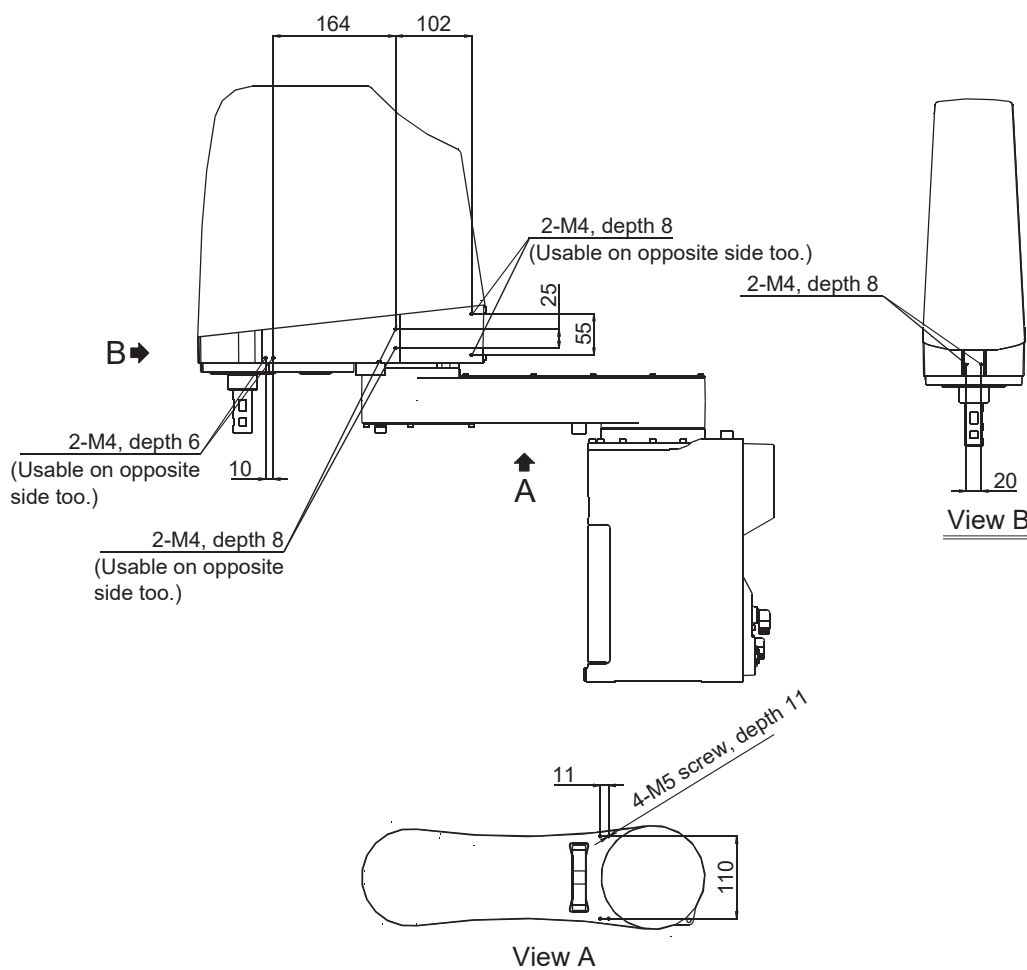

Fig.: Location of screw holes for fixing wiring/piping (RH-3FRH series)

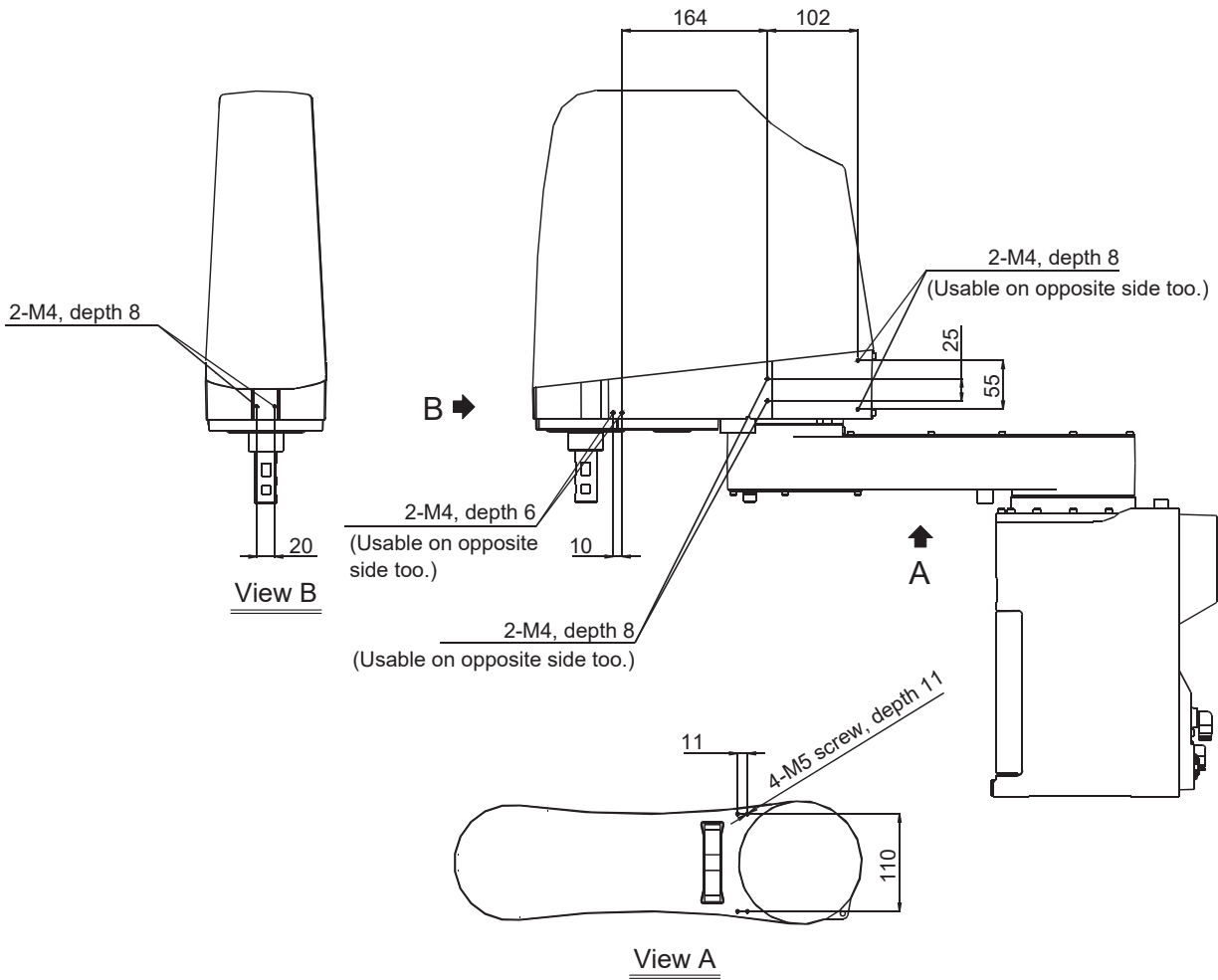

Fig.: Location of screw holes for fixing wiring/piping (RH-6FRH series)

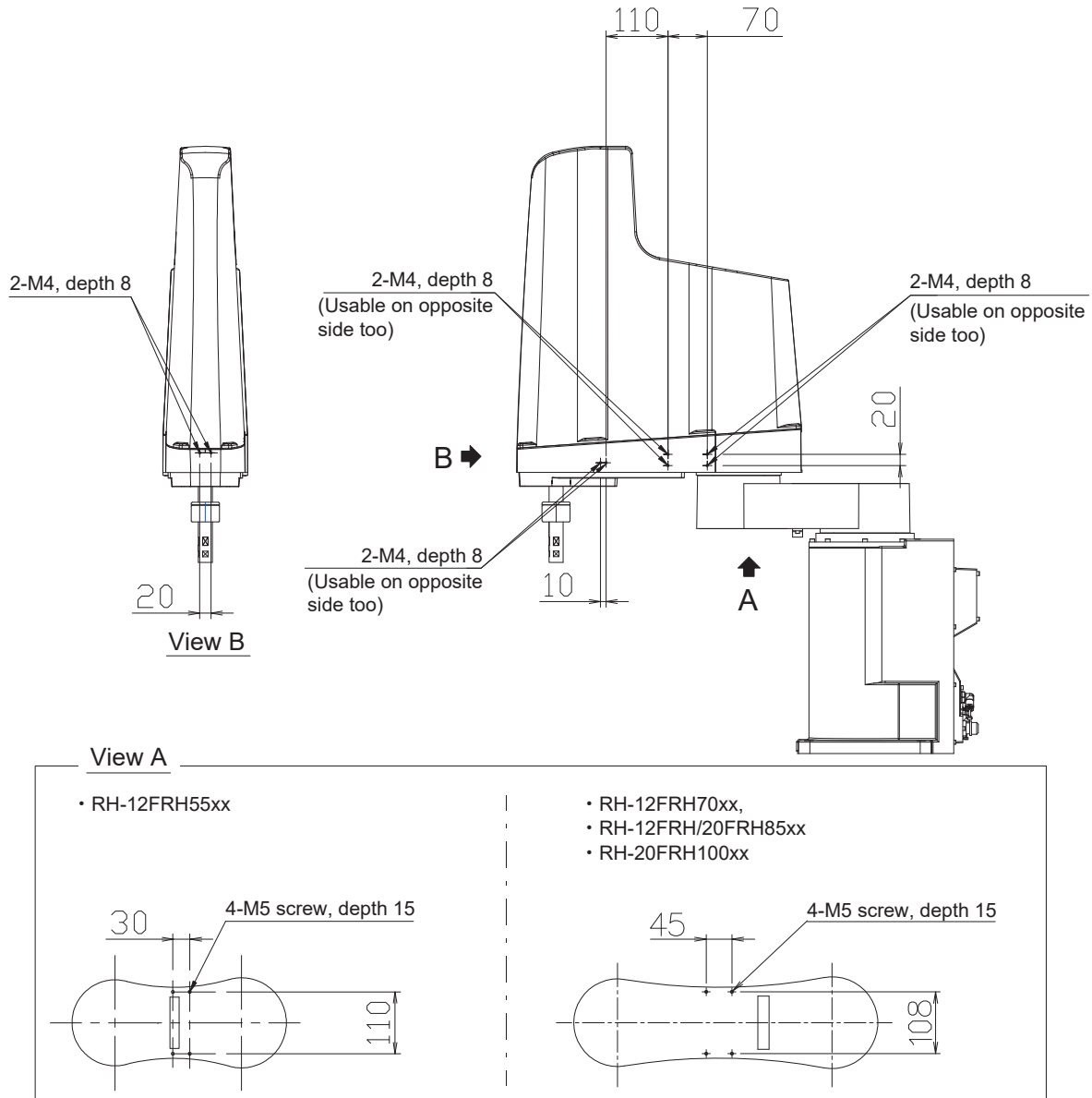

Fig.: Location of screw holes for fixing wiring/piping (RH-12FRH/20FRH series)

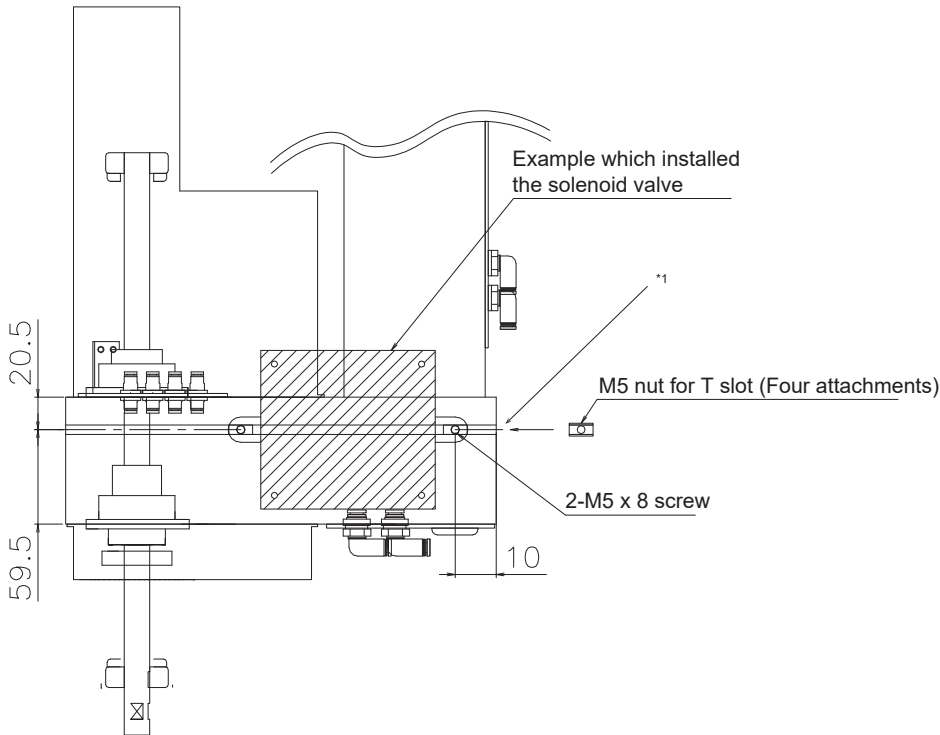

Fig.: Location of screw holes for fixing wiring/piping (RH-3FRHR series)

*1 T slot

The T slot is on the side of the No.2 arm. (Two of right and left) Utilize the M5 screw and T slot for fixing the hose or wire. Refer to Fig.: Outside dimensions, Operating range diagram of RH-3FRHR series (Standard specification) or Fig.: Outside dimensions, Operating range diagram of RH-3FRHR series (Clean/waterproof specification) for detail of T slot. The clean/waterproof robot are supplied with the packing. After fixation of wirings and pipings, stuff the packing into the T slot.

Example of wiring and piping <1>

By feeding wiring and piping through the inside of the shaft, the wiring and piping to the hand becomes compact.

■RH-3FRH series

<RH-3FRH series>

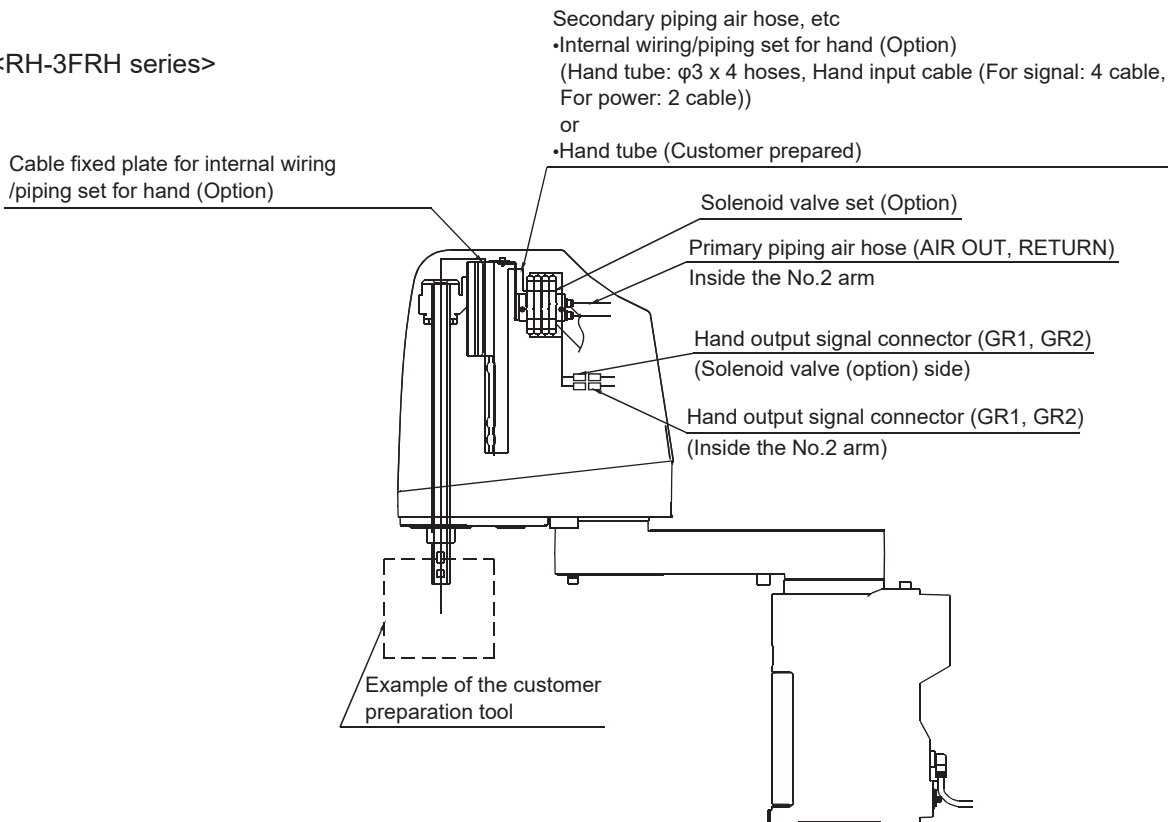

Fig.: Example of wiring and piping <1> (RH-3FRH series)

■RH-6FRH series

<RH-6FRH series>

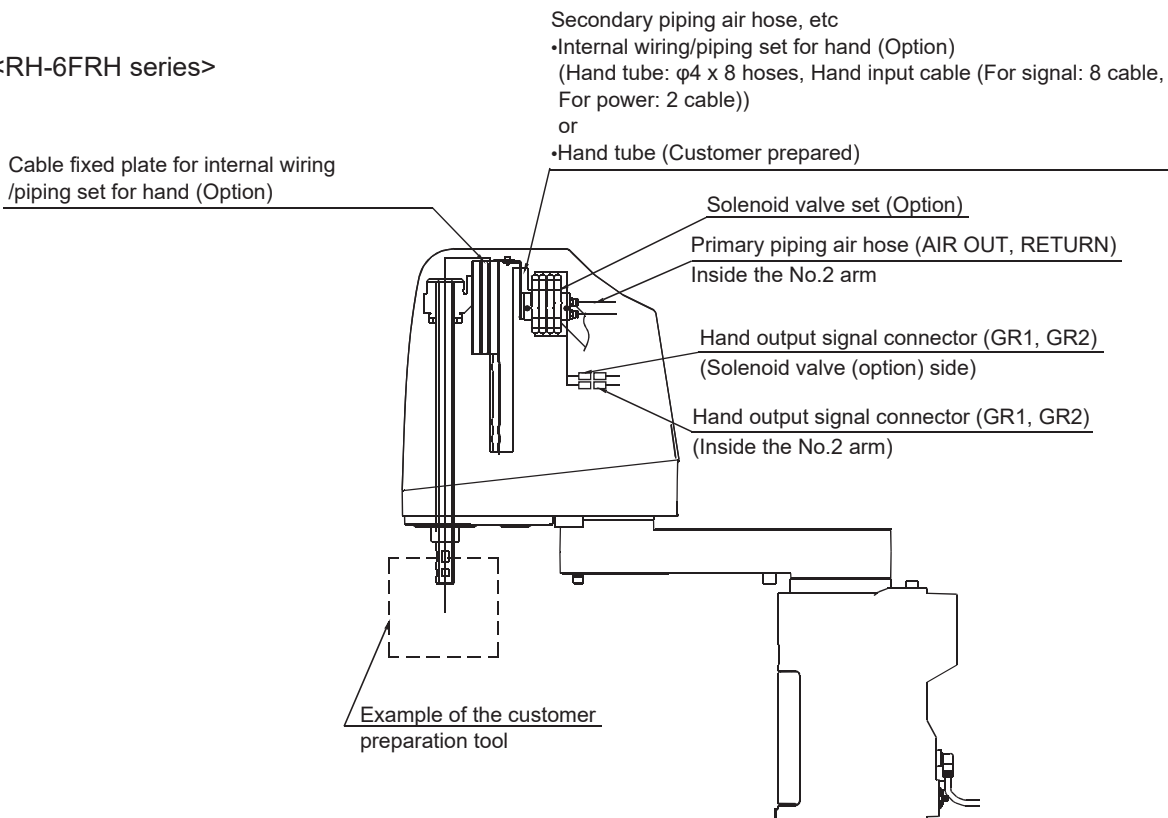

Fig.: Example of wiring and piping <1> (RH-6FRH series)

■RH-12FRH/20FRH series

<RH-12FRH/20FRH series>

Cable fixed plate for internal wiring /piping set for hand (Option)

- Secondary piping air hose, etc
- Internal wiring/piping set for hand (Option)
(Hand tube: $\phi 6 \times 4$ hoses, Hand input cable (For signal: 8 cable, For power: 2 cable))
- or
- Hand tube (Customer prepared)

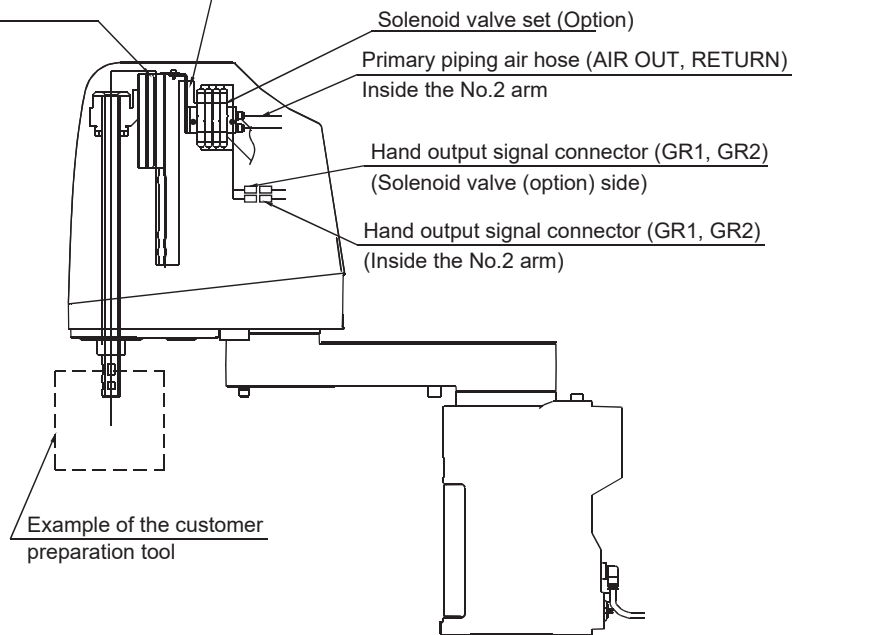
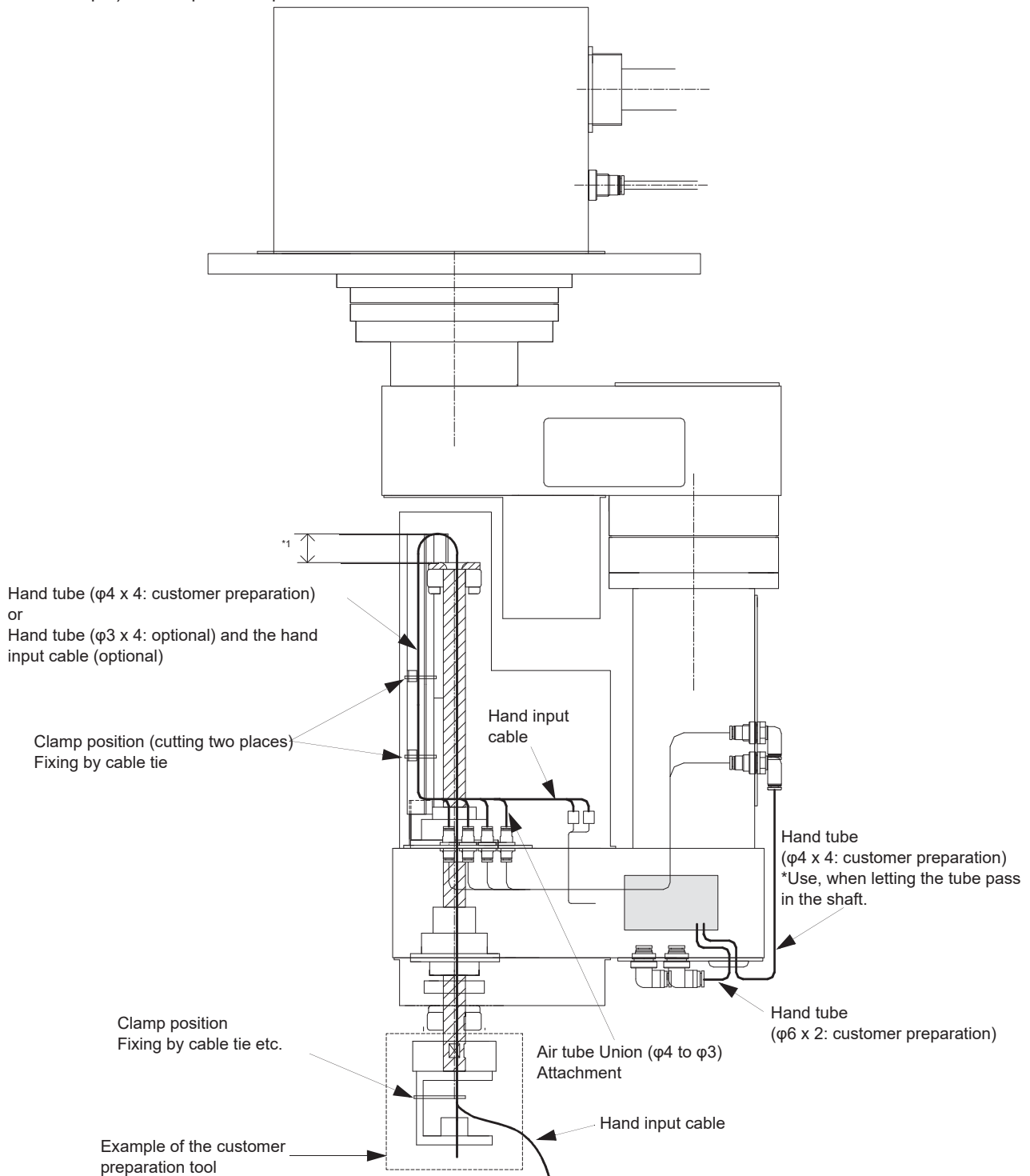

Fig.: Example of wiring and piping <1> (RH-12FRH/20FRH series)

■RH-3FRHR series

<RH-3FRHR series>

Example) How to pass the $\phi 4$ air hose into the shaft



Notes in wiring

1. The air hose which can be passed in the shaft is four $\phi 4$ hoses maximum. (Customer preparations)
2. Wire the cable and piping the tube without interference with ball screw and cover.
3. Because to prevent the bend of the air tube, secure the minimum radius with which tube can be bent.
4. When using an optional solenoid valve, add the mass of solenoid valve to mass of hand and set to parameter: HNDDAT. (RH-3FRHR series only)
5. The hand tube (four $\phi 3$ tubes) and the hand input cable (4 point) are prepared optional. Please confirm that there is no rubbing or crack etc per six months.

Fig.: Example of wiring and piping <1> (RH-3FRHR series)

*1 Adjustment of the fixing position

In the condition that the J3 axis is upper limit and the J4 axis is 0 degree, align the top of air tube with the upper end of the Piping fixing bracket.

Wiring and piping example <2>

This is an effective method in cases where the wiring and piping is often changed, or when the hand rotation is minimal (within $\pm 90^\circ$), etc.

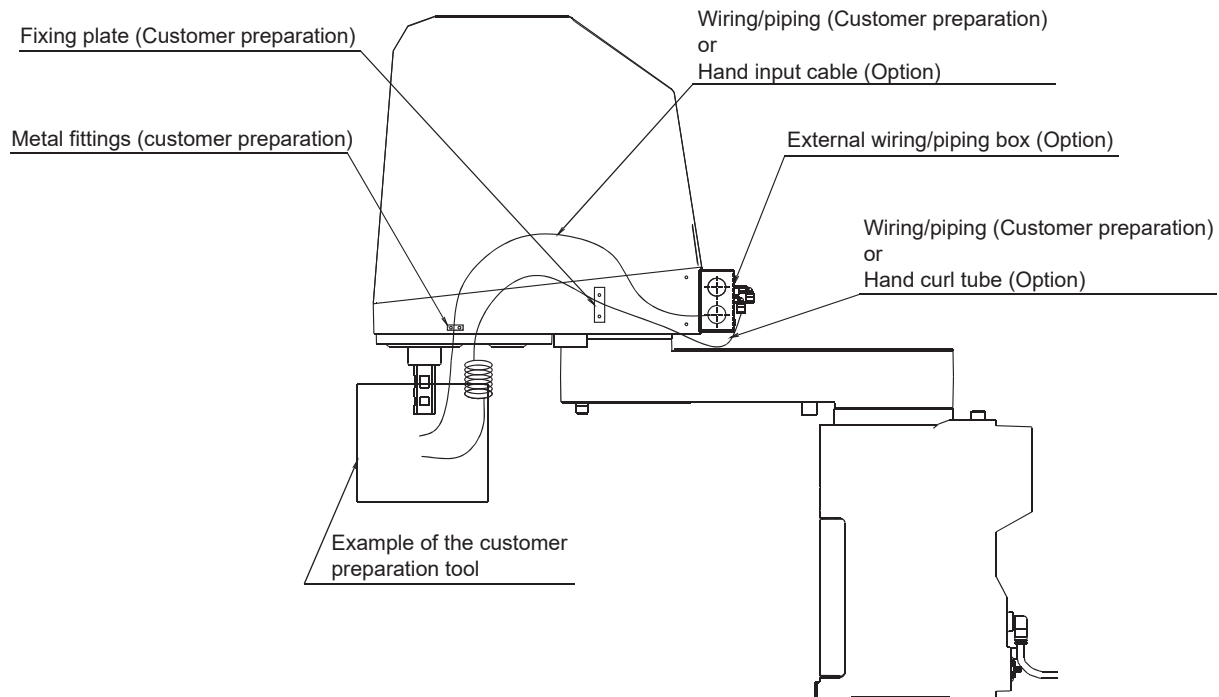



Fig.: Example of wiring and piping <2>

Note) Although the illustration is the RH-3FRH series robot, RH-6FRH/12FRH/20FRH series robot also have the screw holes for fixation of the wiring/piping. (Refer to  Fig.: Location of screw holes for fixing wiring/piping (RH-6FRH series),  Fig.: Location of screw holes for fixing wiring/piping (RH-12FRH/20FRH series).)

Precautions for the oilmist/clean specification

The through hole of the top part of the tip shaft are taped at shipment.

Perform the following actions as necessary in order to ensure that the robot keeps sufficiently protective performance during the operation:

1) When the through hole of the shaft is not used

Keep the top part of the tip shaft taped while the robot is in use.

2) When the through hole of the shaft is used for wiring.

Remove the rubber cap on top of the tip shaft and perform the necessary wiring. Once the wiring is completed, seal the bottom part of the tip shaft using liquid seal in order to avoid accumulation of dust and to protect from oil mist

Perform the wiring in such a way that the wires around the area below the tip shaft will not get into contact with other parts while the robot is operating.

Wiring and piping system diagram for hand

Shows the system configuration of wiring and piping.

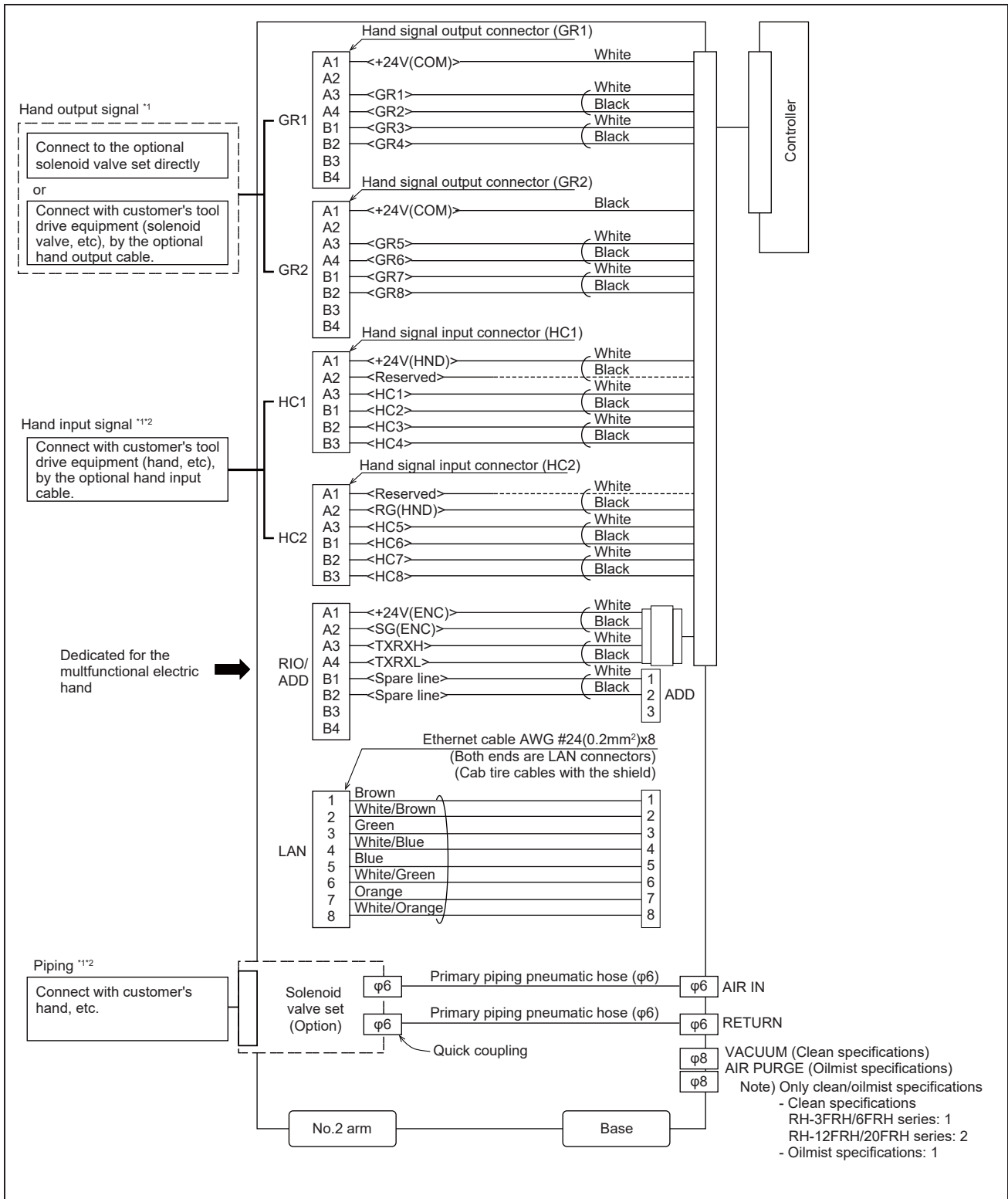





Fig.: Wiring and piping system diagram for hand and example the solenoid valve installation (RH-3FRH/6FRH/12FRH/20FRH series)

- *1 Using the  Page 182 External Wiring/Piping box, the hand output/input signal cable and the air hose can be pulled out externally.
(This option comes equipped with two $\phi 6$ joints for primary piping, eight $\phi 4$ joints for secondary piping (RH-3FRH/6FRH series) or two $\phi 6$ joints for primary piping, eight $\phi 6$ joints for secondary piping (RH-12FRH/20FRH series), and holes for pulling out the cables.)
- *2 Using the  Page 179 Internal Wiring/Piping set for hand, the hand input signal cable and air hose can be fed through the inside of the shaft.
(This option comes as a set that includes $\phi 4 \times 8$ (RH-3FRH/6FRH series) or $\phi 6 \times 4$ (RH-12FRH/20FRH series) air hoses, hand input cables (8 x signal lines, 2 x power chords), and fixing tools.

Refer to  Fig.: Air supply circuit example for the hand for air supply circuit example.

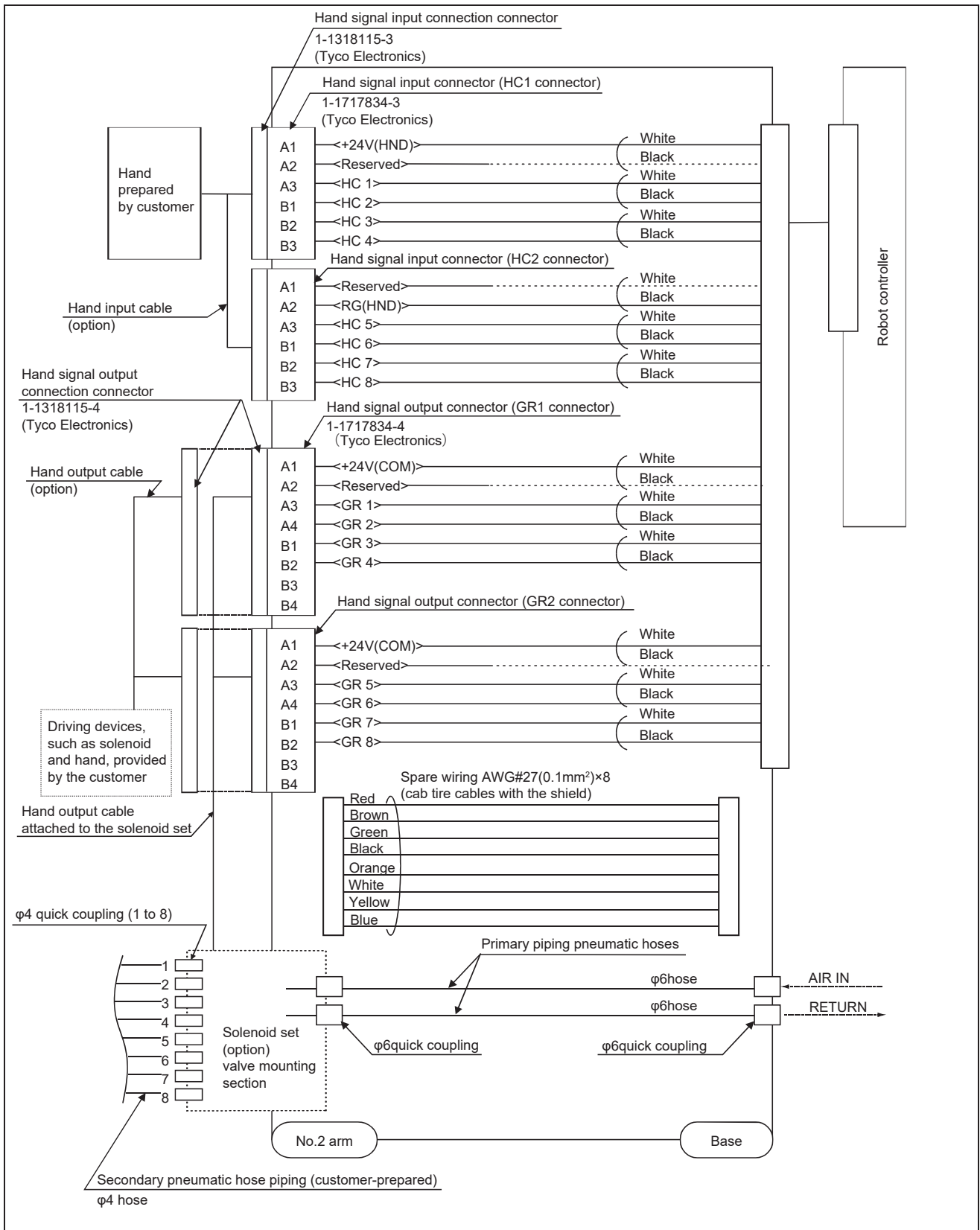

Fig.: Wiring and piping system diagram for hand and example the solenoid valve installation (RH-3FRHR series)
 Refer to Fig.: Air supply circuit example for the hand for Air supply circuit example.

Electrical specifications of hand input/output

Electrical specifications of input circuit

Item	Specifications	Internal circuit	
Type	DC input	<p><Sink type></p> <p><Source type></p> <p>* Hand input: HCn=HC1 to HC8</p>	
No. of input points	8		
Insulation method	Photo-coupler insulation		
Rated input voltage	24VDC		
Rated input current	Approx. 7mA/point		
Working voltage range	DC10.2 to 26.4V (ripple rate within 5%)		
ON voltage/ON current	8VDC or more/2mA or more		
OFF voltage/OFF current	4VDC or less/1mA or less		
Input resistance	Approx. 3.3kΩ		
Response time	OFF-ON		10ms or less (DC24V)
	ON-OFF		10ms or less (DC24V)
Protection function	With an overcurrent protection function (1.0A, total current consumption of the input and output circuits)		

Electrical specifications of output circuit

Item	Specification	Internal circuit	
Type	Transistor output	<p><Sink type></p> <p><Source type></p> <p>*Hand output: GRn=GR1 to GR8</p>	
No. of output points	8		
Insulation method	Digital isolator		
Rated load voltage	DC24V		
Rated load voltage range	DC21.6 to 26.4VDC		
Max. current load	0.1A/ 1 point (100%)		
Current leak with power OFF	0.1mA or less		
Maximum voltage drop with power ON	DC0.9V(TYP.)		
Response time	OFF-ON		2ms or less (hardware response time)
	ON-OFF		2ms or less (resistance load) (hardware response time)
Protection function	Protects the over-current (0.9A)		

Air supply circuit example for the hand

An example of pneumatic supply circuitry for the hand is shown below.

- 1) Make sure that a surge voltage protection circuit such as a diode is connected to the solenoid coil in parallel.
- 2) When the factory pneumatic pressure drops, as a result of the hand clamp strength weakening, there can be damage to the work. To prevent it, install a pressure switch to the source of the air as shown in Fig.: Air supply circuit example for the hand and use the circuit described so that the robot stops when pressure drops. Use a hand with a spring-pressure clamp, or a mechanical lock-type hand, that can be used in cases where the pressure switch becomes damaged.
- 3) The optional hand and solenoid valve are of an oilless type. If they are used, don't use any lubricator.
- 4) Supply clean air to the vacuum generation valve when you use clean specifications robot.
- 5) If the air supply temperature (primary piping) used for the tool etc. is lower than ambient air temperature, the dew condensation may occur on the coupling or the hose surface.

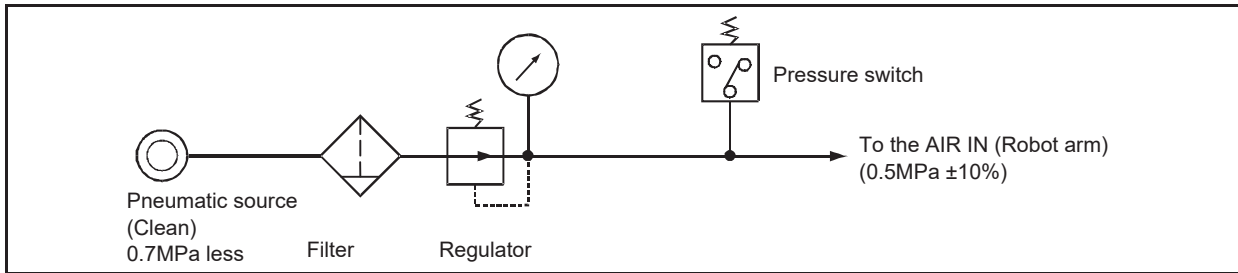

Fig.: Air supply circuit example for the hand

2.6 Options

There are a variety of options for the robot designed to make the setting up process easier for customer needs. customer installation is required for the options.

Machine cable (replacement)

2

Order type

● Fixed type

1F- □□UCBL-41

● Flexed type

1F- □□LUCBL-41

Note) The numbers in the boxes □□ refer the length.

Outline



This cable is used for extending or shortening the distance between the controller and the robot.

A fixed type and flexible type are available.

Exchanges with the machine cable attached in the standards.

Configuration

Table: Configuration equipment and types

Part name	Type *1	Qty.	Mass (kg) *2	Remarks
Machine cable (replacement) fixed type	1F-□□UCBL-41	1 cable	2.6 (2m) 5 (5m) 9 (10m) 13 (15m) 17 (20m)	2m, 5m, 10m, 15m or 20m each
Machine cable (replacement) flexed typ	1F-□□LUCBL-41	1 cable	11 (10m) 16 (15m) 21 (20m)	10m, 15m or 20m each
Nylon clamp	NK-24N	2 pcs.	—	
Silicon rubber		2 pcs.	—	

*1 The numbers in the boxes □□ refer the length.

*2 Mass indicates one set.

Specifications

The specifications for the fixed type cables are the same as those for standard cables. Shows usage conditions for flexed type cables in [Table: Conditions for the flexed type cables](#).

Table: Conditions for the flexed type cables

Item	Specifications
Minimum flexed radius	100mm or more
Cableveyor, etc., occupation rate	50% or less
Maximum movement speed	2,000mm/s or less
Guidance of life count	7.5 million times (With silicone grease coating)
Environmental proof	IP54
Cable configuration	$\phi 8.9 \times 3$, $\phi 6.5 \times 6$, $\phi 6.2 \times 1$, $\phi 6 \times 6$

[Caution]

The guidance of life count may greatly differ according to the usage state items related to [Table: Conditions for the flexed type cables](#) and to the amount of silicon grease applied in the cableveyor.

Recommendation grease: G-501 (Supplier: Shin-Etsu Chemical Co., Ltd.)

[Caution]

This option can be installed on clean-type, but its cleanliness is not under warranty.

[Caution]

When a cableveyor is used, partitions are required to avoid overlapping or riding up of the cables. Also, adjust the cable length to eliminate tension or excessive looseness, and fix it securely.

Cable configuration

The configuration of the flexible cable is shown in [Table: Cable configuration \(Flexed type\)](#).

Refer to this table when selecting the cableveyor.

Table: Cable configuration (Flexed type)

Item	Motor signal cable		Motor power cable	
	AWG #24 (0.2mm ²)-4P	AWG #28 (0.08mm ²)-4P	AWG #16 (1.25mm ²)-4C	AWG #18 (0.75mm ²)-3C
Finish dimensions	Approx. $\phi 6$ mm	Approx. $\phi 6.2$ mm	Approx. $\phi 8.9$ mm	Approx. $\phi 6.5$ mm
No. of cables used	6	1	3	6
No. in total	7		9	

Fixing the flexible cable

(1) Connect the connector to the robot arm.

The connection method to a robot arm is the same as a standard machine cable. Please refer to  RH-FRH Series INSTRUCTION MANUAL ROBOT ARM SETUP & MAINTENANCE (BFP-A3472) and connect.

(2) Wind the silicon rubber around the cable at a position 300 to 400 mm from the side of robot arm and extension section as shown below, and fix with the nylon clamp to protect the cable from external stress.

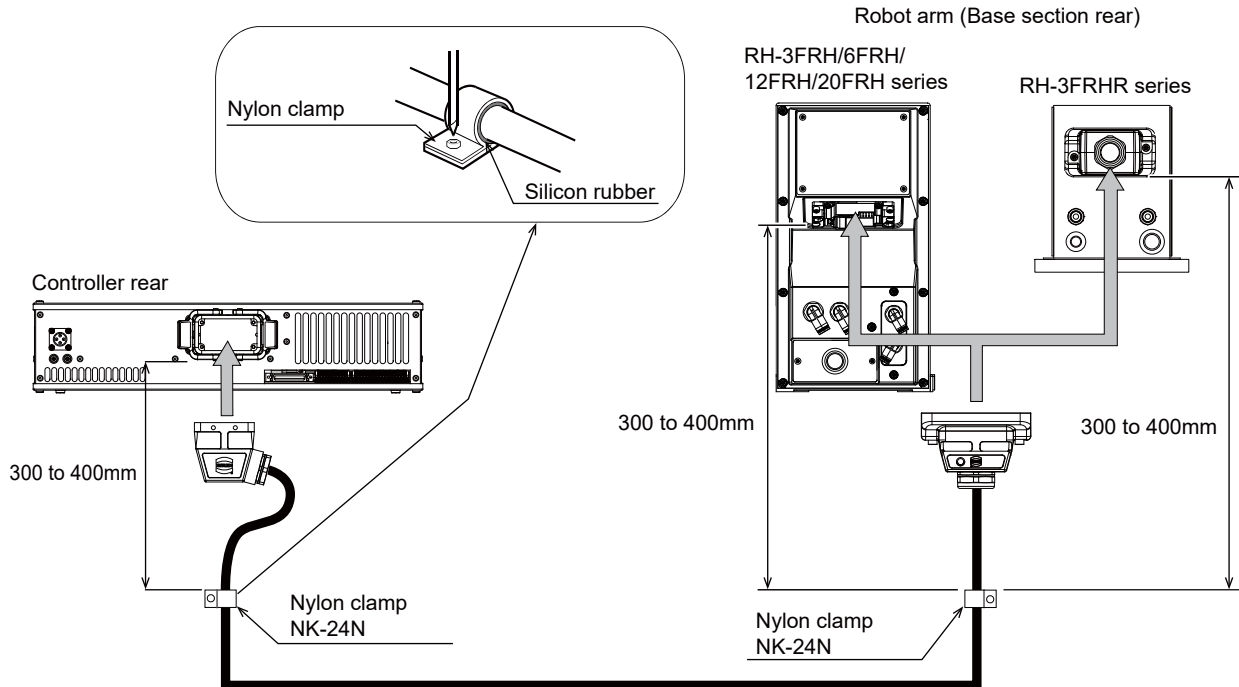

The bend size of cables are as follows.

<RH-3FRH/6FRH series>

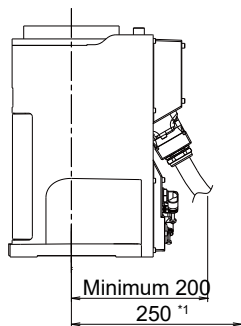

<RH-12FRH/20FRH series>

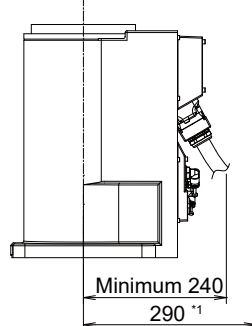

<RH-3FRHR series>

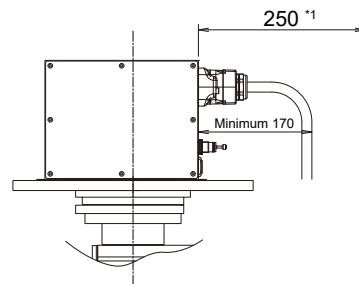

Fig.: Fixing the flexible cable

*1 The connection space for a machine cable.

Stopper for changing the operating range

Order type

●RH-3FRH/6FRH series

J1 axis: 1F-DH-01

●RH-12FRH/20FRH series

J1 axis: 1F-DH-02

●RH-3FRHR series

J1 axis: 1S-DH-05J1

J2 axis: 1S-DH-05J2

Outline

RH-3FRH/6FRH/12FRH/20FRH series



RH-3FRHR series



The operating range axis is limited by the robot arm's mechanical stopper and the controller parameters. You can change the operating range of the following axis.

Model	Axis
RH-3FRH/6FRH/12FRH/20FRH series	J1 axis
RH-3FRHR series	J1, J2 axis

If the axis could interfere with the peripheral devices, etc., and the operating range need to be limited, use this.

Configuration

Table: Configuration devices

Part name	Type	Qty.	Mass(kg)	Remarks
RH-3FRH/6FRH series				
Stopper for changing the operating range	1F-DH-01	1 set	0.05	hexagon socket head bolt (M10 x 20): 2 bolts
RH-12FRH/20FRH series				
Stopper for changing the operating range	1F-DH-02	1 set	0.05	hexagon socket head bolt (M12 x 20): 2 bolts
RH-3FRHR series				
Stopper for changing the operating range	1S-DH-05J1	1 set	0.1	Pin (φ10 x 2) Installation bolt (M4 x 12): two attachments
	1S-DH-05J2	1 set	0.1	Pin (φ8 x 2) Installation bolt (M4 x 12): two attachments

Specifications

Table: Specifications



Axis		Standard	Changeable angle
RH-3FRH/6FRH/12FRH/20FRH series			
J1	+/- side	+/- 170 deg	+/- 130 deg, +/- 150 deg
RH-3FRHR series *1			
J1	+/- side	+/- 225 deg	+/- 90 deg
J2	+/- side	+/- 225 deg	+/- 60 deg

*1 Although the J1 axis and the J2 axis can be changed independently (independent per axis), each axis changes plus side /minus side both simultaneously per axis.

(1) The changeable angle shown in  Table: Specifications indicates the operation range by the software.

The limit by the mechanical stopper is positioned 3 degrees outward from that angle, so take care when designing the layout.

(2) The operating range is changed with robot arm settings (insertion of the pin) and parameter settings.

Refer to  RH-FRH Series INSTRUCTION MANUAL ROBOT ARM SETUP & MAINTENANCE (BFP-A3472) and  CR800 Series Controller INSTRUCTION MANUAL Detailed explanations of functions and operations (BFP-A3478) for details.

(3) If the arm collides with mechanical stopper for operating range change at the automatic operation, replacement of the mechanical stopper is necessary.

Solenoid valve set

Order type

●RH-3FRH/6FRH series

One set: 1F-VD01-01(Sink type)/1F-VD01E-01(Source type)

Two sets: 1F-VD02-01(Sink type)/1F-VD02E-01(Source type)

Three sets: 1F-VD03-01(Sink type)/1F-VD03E-01(Source type)

Four sets: 1F-VD04-01(Sink type)/1F-VD04E-01(Source type)

●RH-12FRH/20FRH series

One set: 1S-VD01-01(Sink type)/1S-VD01E-01(Source type)

Two sets: 1S-VD02-01(Sink type)/1S-VD02E-01(Source type)

Three sets: 1S-VD03-01(Sink type)/1S-VD03E-01(Source type)

Four sets: 1S-VD04-01(Sink type)/1S-VD04E-01(Source type)

●RH-3FRHR series (Four sets)

- Standard specification

1S-VD04-05(Sink type)

1S-VD04E-05(Source type)

- Clean/waterproof specification

1S-VD04W-05(Sink type)

1S-VD04WE-05(Source type)

Outline

<RH-3FRH/6FRH/12FRH/20FRH series>



•1F-VD0*-01
•1F-VD0*E-01

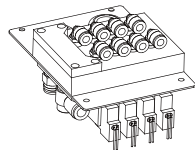

•1S-VD0*-01
•1S-VD0*E-01

<RH-3FRHR series>

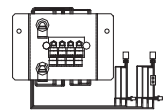

•1S-VD04-05
•1S-VD04E-05







•1S-VD04W-05
•1S-VD04WE-05

The solenoid valve set is an option that is used for controlling toolings when various toolings, such as the hand, are installed at the end of the arm.

Also, for easy installation of this electromaagnetic set onto the robot, it comes equipped with a manifold, couplings,connectors, among other things.

Configuration

Table: Configuration equipment

Part name	Type	Q'ty	Mass(kg) *1	Remark
RH-3FRH/6FRH series				
Solenoid valve set (1 sets)	1F-VD01-01/ 1F-VD01E-01	Either one pc.	1.0	Hand output cable is already connected. Refer to  Page 174 Hand output cable. M4 x 30 Two screws (Installation screws) 1F-VD0*-01: Sink type 1F-VD0*E-01: Source type.
Solenoid valve set (2 sets)	1F-VD02-01/ 1F-VD02E-01	Either one pc.	1.0	
Solenoid valve set (3 sets)	1F-VD03-01/ 1F-VD03E-01	Either one pc.	1.0	
Solenoid valve set (4 sets)	1F-VD04-01/ 1F-VD04E-01	Either one pc.	1.0	
RH-12FRH/20FRH series				
Solenoid valve set (1 sets)	1S-VD01-01/ 1S-VD01E-01	Either one pc.	1.0	Hand output cable is already connected. Refer to  Page 174 Hand output cable. M4 x 8 Two screws (Installation screws) 1S-VD0*-01: Sink type 1S-VD0*E-01: Source type.
Solenoid valve set (2 sets)	1S-VD02-01/ 1S-VD02E-01	Either one pc.	1.0	
Solenoid valve set (3 sets)	1S-VD03-01/ 1S-VD03E-01	Either one pc.	1.0	
Solenoid valve set (4 sets)	1S-VD04-01/ 1S-VD04E-01	Either one pc.	1.0	
RH-3FRHR series				
Solenoid valve set (4 sets)	1S-VD04-05/ 1S-VD04E-05	Either one pc.	0.6	For Standard specification Hand output cable is already connected. Refer to  Page 174 Hand output cable. M5 x 8 Two screws (Installation screws) Fixing nut for T slot : Two nuts 1S-VD04-05: Sink type 1S-VD04E-05: Source type
Solenoid valve set (4 sets)	1S-VD04W-05/ 1S-VD04WE-05	Either one pc.	0.6	For Clean/Waterproof specification Hand output cable is already connected. Refer to  Page 174 Hand output cable. M5 x 8 Two screws (Installation screws) Fixing nut for T slot : Two nuts 1S-VD04W-05: Sink type 1S-VD04WE-05: Source type

*1 Mass indicates one set.

Specifications

Table: Valve specifications

Item	Specifications	
Solenoid valve set type	1F-VD0*-01, 1F-VD0*E-01 1S-VD04-05, 1S-VD04E-05 1S-VD04W-05, 1S-VD04WE-05	1S-VD0*-01, 1S-VD0*E-01
Number of positions	2	
Port	5 *1	
Valve function	Double solenoid	
Operating fluid	Clean air *2	
Operating method	Internal pilot method	
Effective sectional area (CV value)	1.1mm ² (0.06)	7.92mm ² (0.44)
Oiling	Unnecessary	
Operating pressure range	0.1 to 0.7MPa	
Response time	15ms or less (at 0.5 MPa)	22ms or less (at 0.5 MPa)
Max. operating frequency	10Hz	5Hz
Ambient temperature	-10 to 50°C(However, there must be no condensation.)	

*1 Couplings of unused solenoid valves must be blocked with plugs. If they are not blocked, supplied air will blow out from the couplings, lowering the air pressure of the solenoid valves being used and making them nonfunctional.

Recommended plugs: KQ2P-04 plug (RH-3FRH/6FRH series, RH-3FRHR series) made by SMC
KQ2P-06 plug (RH-12FRH/20FRH series) made by SMC.

*2

CAUTION

The air to be provided must be clean, i.e., filtered with a mist separator or air filter. Failing to do so may lead to malfunctions.

Table: Solenoid specifications

Item	Specifications
Method	Built-in fly-wheel diodes with surge protection
Coil rated voltage	DC24V ±10%
Power consumption	0.55W
Voltage protection circuit with power surge protection	Diode

<RH-3FRH/6FRH series>

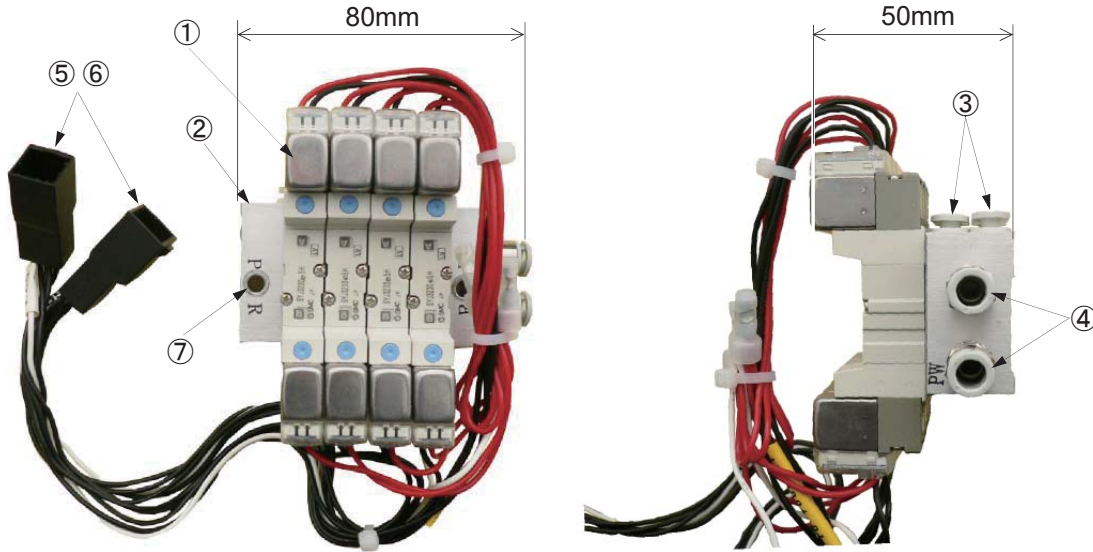

<Sink type>

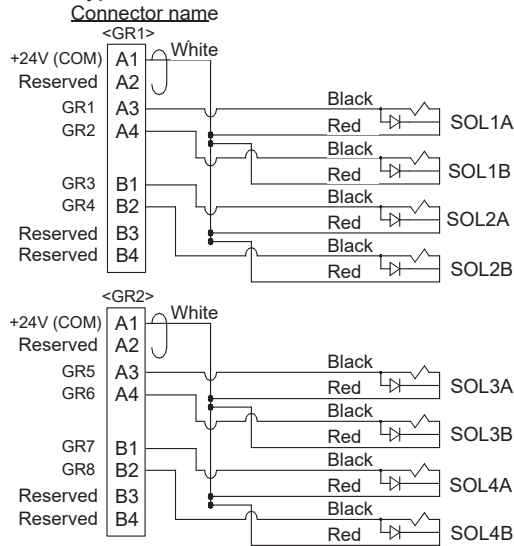

<Source type>

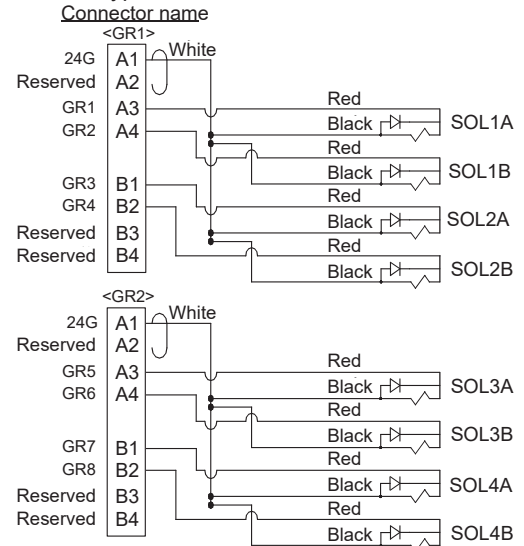

	Part name	1 set	2 sets	3 sets	4 sets	Specification
①	Solenoid valve	1	2	3	4	
②	Manifold block	1	1	1	1	
③	Quick coupling (A/ B port)	8	8	8	8	φ 4
④	Quick coupling (P/ R port)	2	2	2	2	φ 6
⑤	Connector	1	1	2	2	1- 1318115- 4
⑥	Contact	3	5	8	10	1318112- 1
⑦	Installation screw (Combination slotted-cross recessed pan head machine screw)	2	2	2	2	M4x30

Note) The hand output cable (1F-GR60S-01: Option) is unnecessary.

Fig.: Outline dimensional drawing (RH-3FRH/6FRH series)

<RH-12FRH/20FRH series>

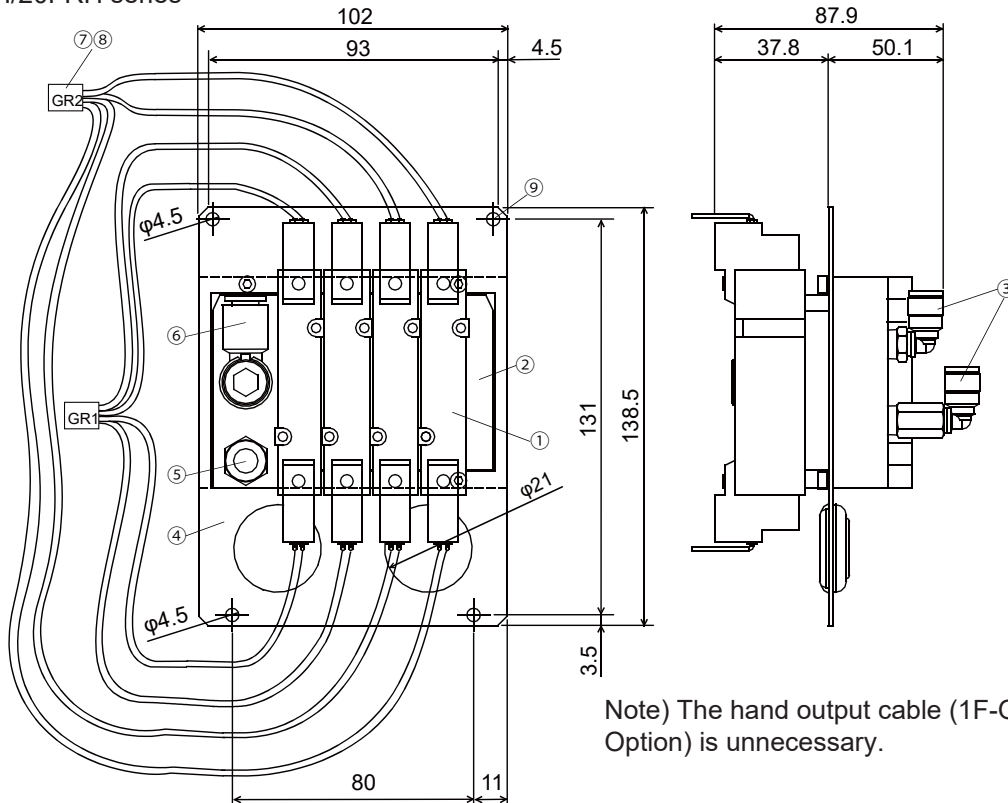

Note) The hand output cable (1F-GR60S-01: Option) is unnecessary.

<Sink type>

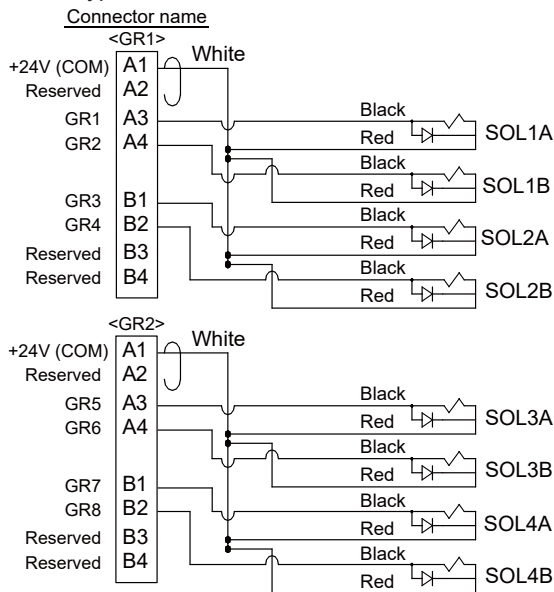

<Source type>

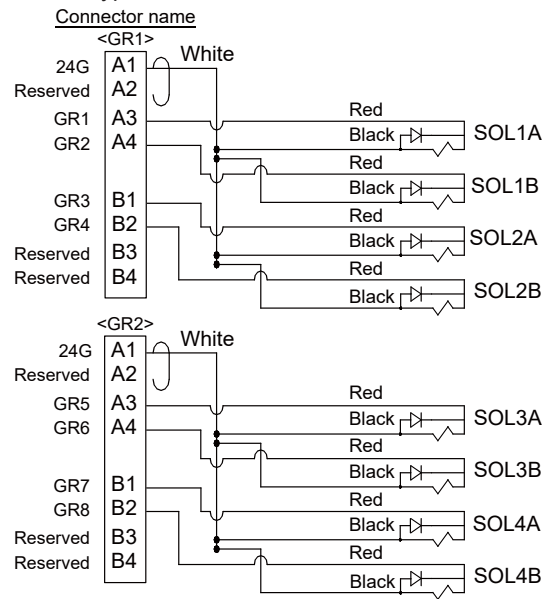

Part No.	Part name	1 sets	1 sets	1 sets	1 sets	Specifications
①	Solenoid valve	1	2	3	4	
②	Manifold block	1	1	1	1	
③	Quick coupling	2	4	6	8	φ6
④	Block plate	1	1	1	1	
⑤	Quick coupling	1	1	1	1	φ6
⑥	Quick coupling	1	1	1	1	φ6
⑦	Connector	1	1	2	2	1-1318115-4
⑧	Contact	3	5	8	10	1318112-1
⑨	Installation screw	4	4	4	4	M4×8

Fig.: Outline dimensional drawing (RH-12FRH/20FRH series)

RH-3FRHR series (Standard specification)

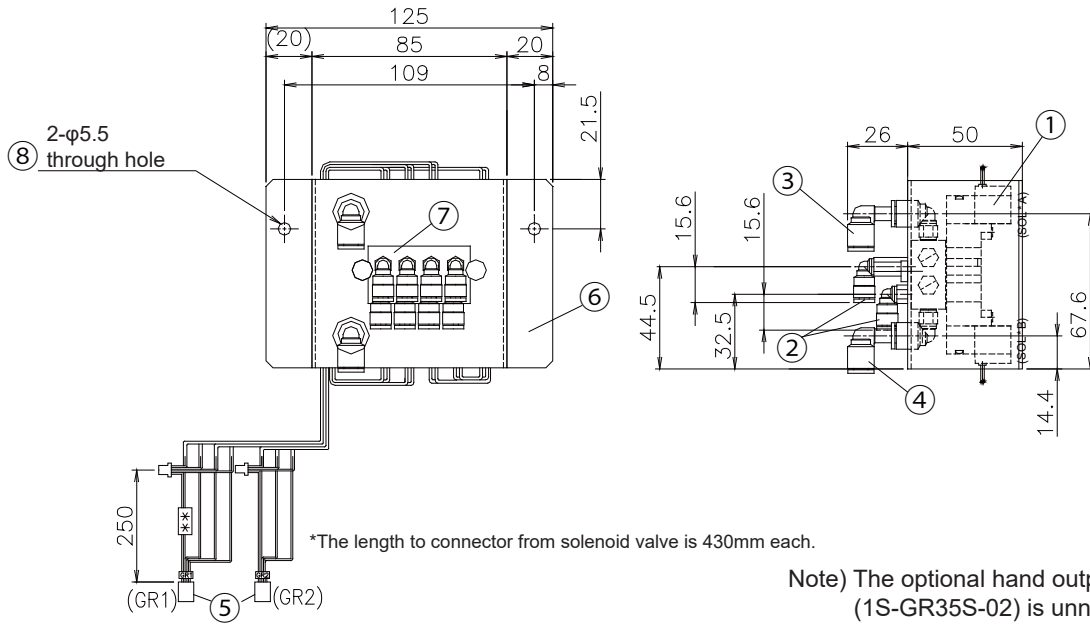

<Sink type>

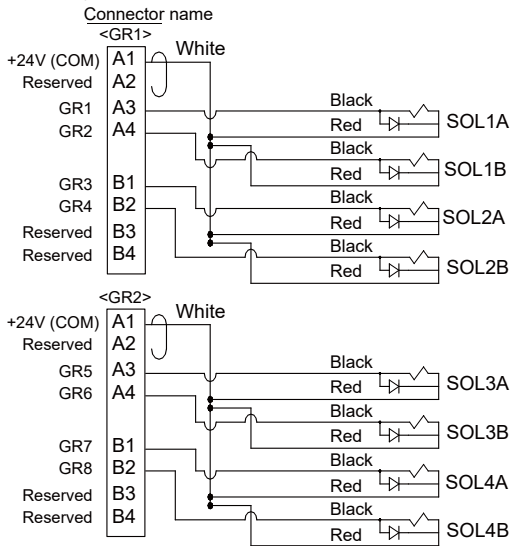

<Source type>

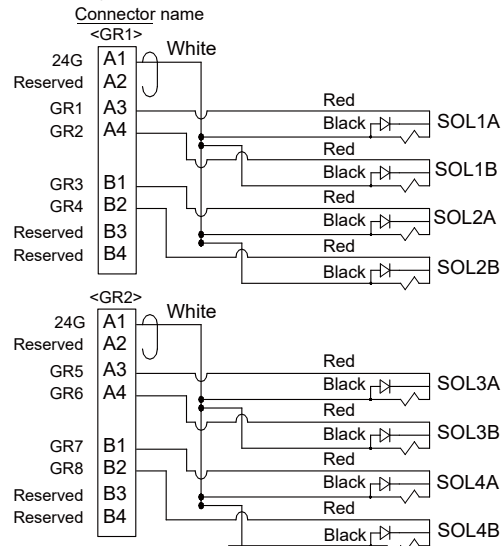

Part No.	Part name	Qty.	Specifications
①	Solenoid valve	4	
②	Quick coupling	8	φ4 (Elbow)
③	Quick coupling	1	φ6 (Elbow)
④	Quick coupling	1	φ6 (Elbow)
⑤	Connector	2	1-1318115-4
	Contact	12	1318112-1
⑥	Solenoid valve cover	1	
⑦	Manifold block	1	
⑧	Installation screw	2	Fixing screw M5x8, spring washer, plain washer (attachments)

Fig.: Outline dimensional drawing (RH-3FRHR series: Standard specification)

RH-3FRHR series (Clean/waterproof specification)

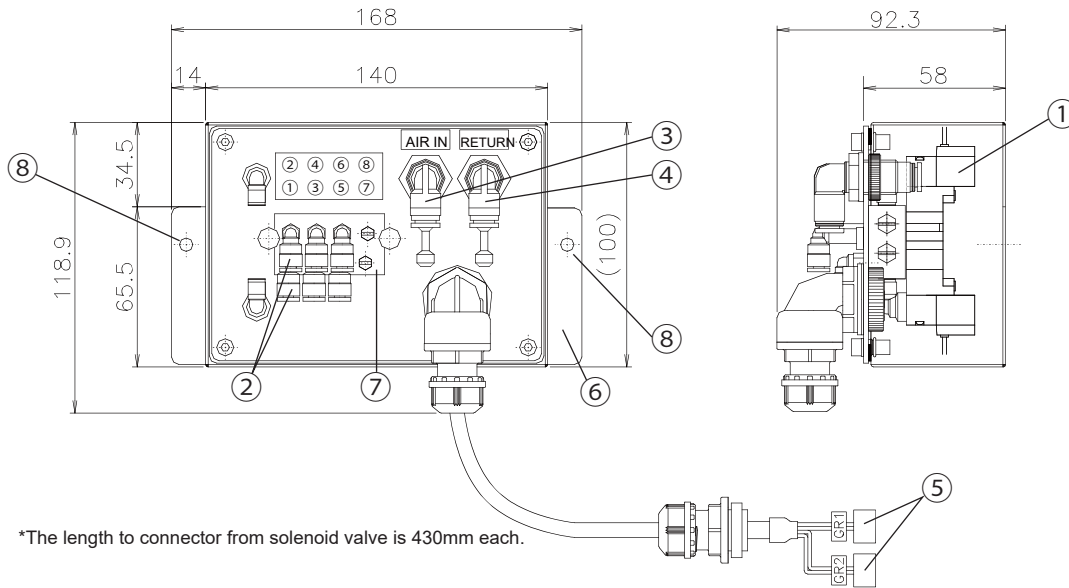

<Sink type>

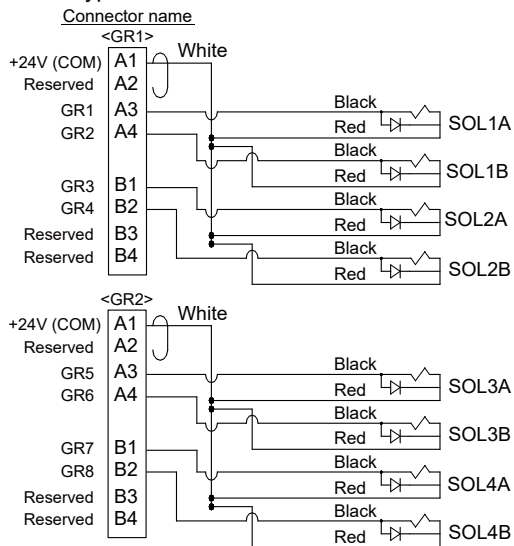

<Source type>

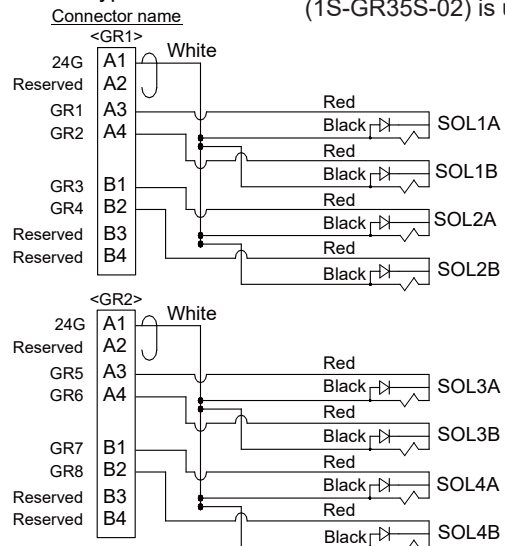

Note) The optional hand output cable (1S-GR35S-02) is unnecessary.

Part No.	Part name	Qty.	Specifications
①	Solenoid valve	4	
②	Quick coupling	8	φ4 (Elbow)
③	Quick coupling	1	φ6 (Elbow)
④	Quick coupling	1	φ6 (Elbow)
⑤	Connector	2	1-1318115-4
	Contact	12	1318112-1
⑥	Solenoid valve cover	1	
⑦	Manifold block	1	
⑧	Installation screw	2	Fixing screw M5x8, spring washer, plain washer (attachments)

Fig.: Outline dimensional drawing (RH-3FRHR series: Clean/waterproof specification)

Hand input cable

Order type

- RH-3FRH/6FRH series
1F-HC35C-01
- RH-12FRH/20FRH series
1F-HC35C-02
- RH-3FRHR series
1S-HC00S-01

Outline

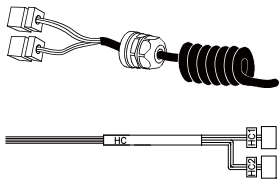

The hand input cable is used for customer-designed pneumatic hands.

It is necessary to use this to receive the hand's open/close confirmation signals and grasping confirmation signals, at the controller.

One end of the cable connects to the connector for hand input signals, which is in the wrist section of the hand.

The other end of the cable connected to the sensor inside the hand c customer designed.

For the following models, the The optional external wiring/piping box is required to extend the wiring to the outside of the robot arm. Refer to [Page 182 External Wiring/Piping box](#)" in detail.

Model	External wiring/piping box
RH-3FRH/6FRH series	1F-UT-BOX
RH-12FRH/20FRH series	1F-UT-BOX-01

Configuration

Table: Configuration equipment

Part name	Type	Qty.	Mass (kg) ^{*1}	Remarks
RH-3FRH/6FRH series				
Hand input cable	1F-HC35C-01	1 cable	0.2	
RH-12FRH/20FRH series				
Hand input cable	1F-HC35C-02	1 cable	0.2	
RH-3FRHR series				
Hand input cable	1S-HC00S-01	1 cable	0.1	Three rubber sheets, seven cable clamp attachment

*1 Mass indicates one set.

Specifications

Table: Specifications

Item	Specifications	Remarks
RH-3FRH/6FRH series		
Size x cable core	AWG#24 (0.2mm ²)×12	One-sided connector, one-sided cable bridging
Total length	1,650mm (Including the curl section, which is 350mm long)	
RH-12FRH/20FRH series		
Size x cable core	AWG#24 (0.2mm ²)×12	One-sided connector, one-sided cable bridging
Total length	1,800mm (Including the curl section, which is 350mm long)	
RH-3FRHR series		
Size x cable core	AWG#24 (0.2mm ²)×6	One-sided connector, one-sided cable bridging
Total length	1,210mm	

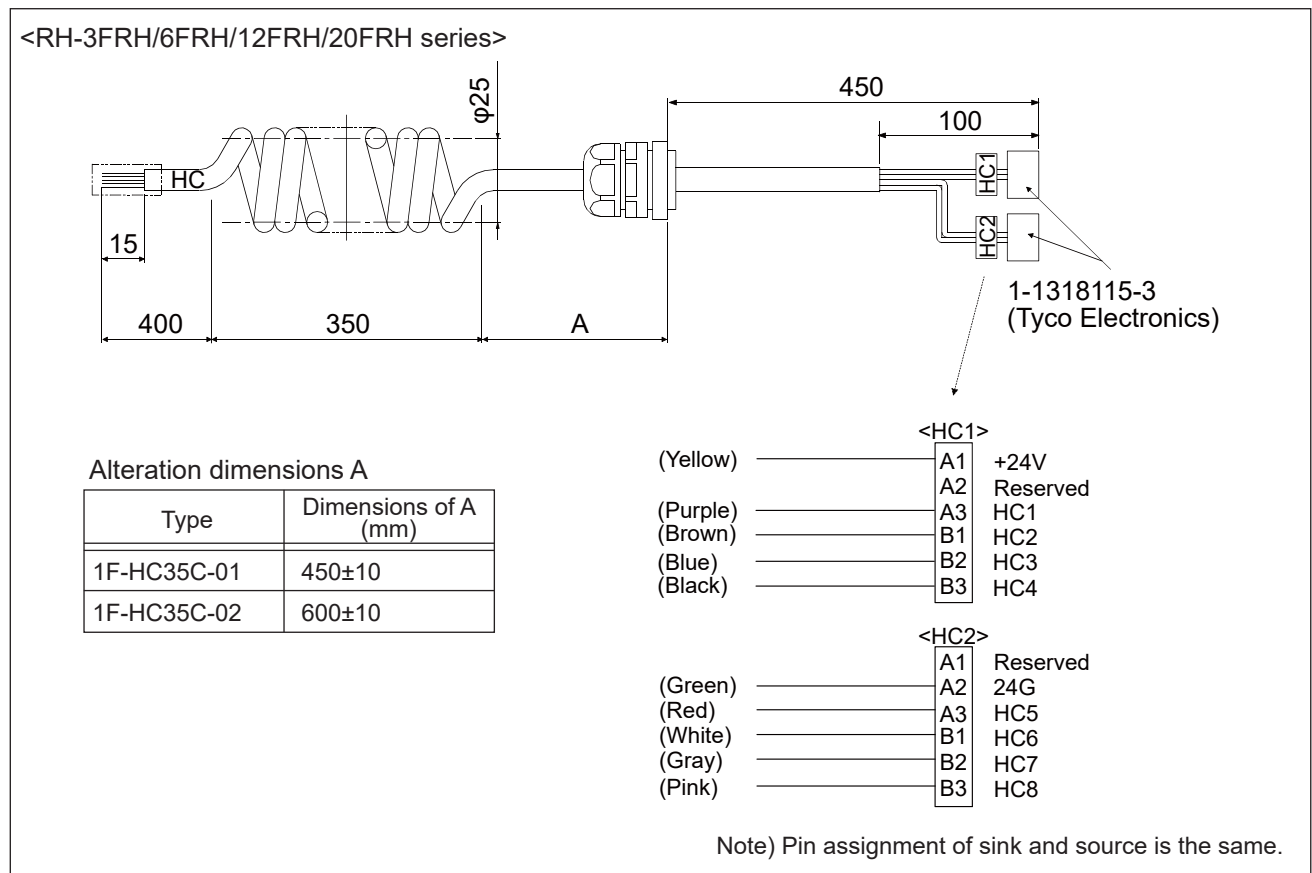

Fig.: Outside dimensional drawing and pin assignment (RH-3FRH/6FRH/12FRH/20FRH series)

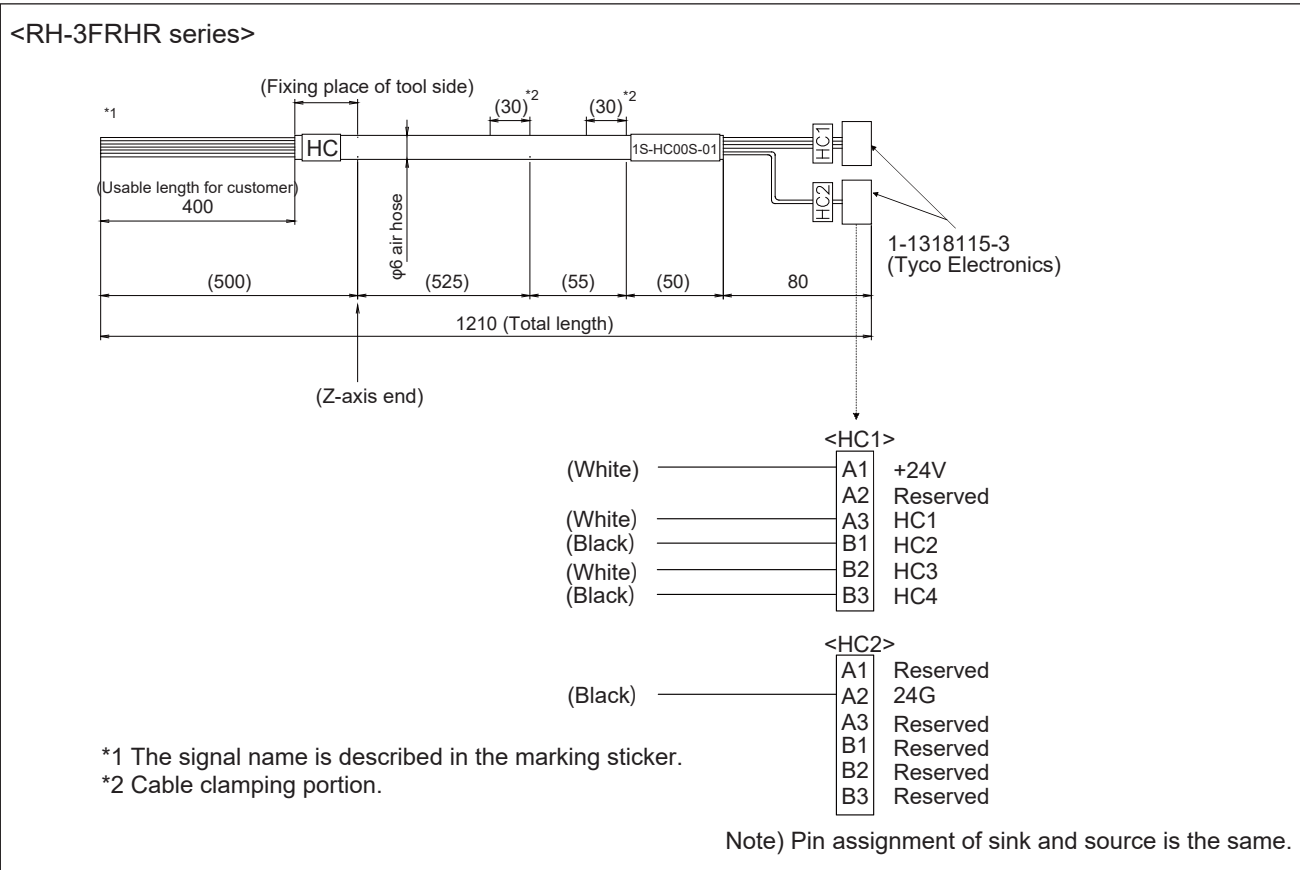

Fig.: Outside dimensional drawing and pin assignment (RH-3FRHR series)

[Caution]

This option can be installed on clean-type, but its cleanliness is not under warranty.

Hand output cable

Order type

●RH-3FRH/6FRH/12FRH/20FRH series

1F-GR60S-01

●RH-3FRHR series

1S-GR35S-02

Outline



The hand output cable (solenoid valve connection cable) is an option that is used when a solenoid valve other than one of the solenoid valve set options, is used.

One end of the cable has a connector that connects to the input terminal inside the robot.

The other end of the cable is connected.

For the following models, the The optional external wiring/piping box is required to extend the wiring to the outside of the robot arm. Refer to Page 182 External Wiring/Piping box in detail.

Model	External wiring/piping box
RH-3FRH/6FRH series	1F-UT-BOX
RH-12FRH/20FRH series	1F-UT-BOX-01

Configuration

Table: Configuration equipment

Part name	Type	Qty.	Mass (kg) *1	Remarks
Hand output cable	1F-GR60S-01	1 cable	0.3	For RH-3FRH/6FRH/12FRH/20FRH series
	1S-GR35S-02	1 cable	0.2	For RH-3FRHR series

*1 Mass indicates one set.

Specifications

Table: Specifications

Item	Specifications	Remarks
Size x Cable core	AWG#24(0.2mm ²) x 12 cores	One side connector and one side cable connection
Total length	1,050mm	For RH-3FRH/6FRH/12FRH/20FRH series (1F-GR60S-01)
	450mm	For RH-3FRHR series (1S-GR35S-02)

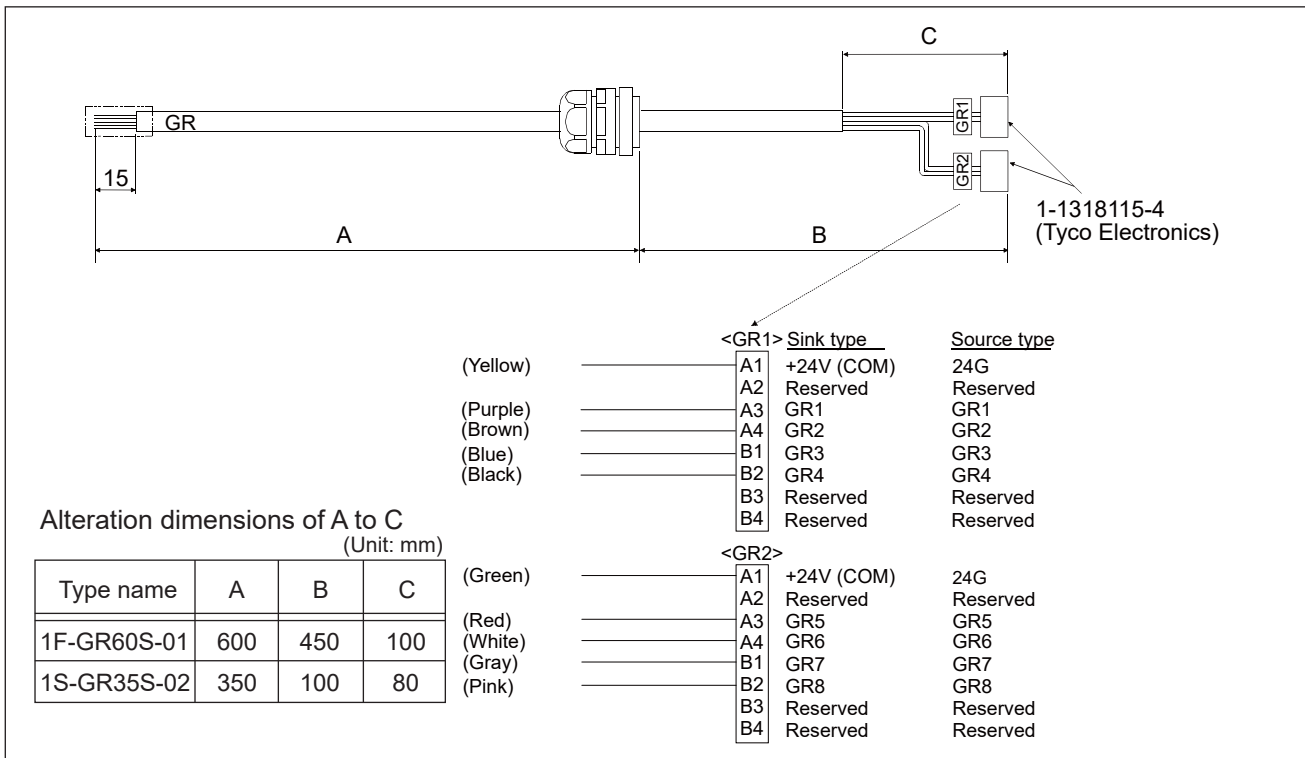

Fig.: Outline dimensional drawing and pin assignment

[Caution]

This option can be installed on clean-type, but its cleanliness is not under warranty.

Hand curl tube

Order type

●RH-3FRH/6FRH series

Four sets: 1E-ST0408C-300

●RH-12FRH/20FRH series

Four sets: 1N-ST0608C-01

Outline

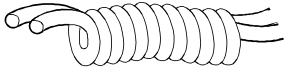

The hand curl tube is a curl tube for the pneumatic hand.

Configuration

Table: Configuration equipment

Part name	Type	Qty.	Mass(kg) ^{*1}	Remarks
RH-3FRH/6FRH series				
Hand curl tube (Four set: 8 pcs.)	1E-ST0408C-300	1 pc.	0.1	φ4 tube, 8pcs
RH-12FRH/20FRH series				
Hand curl tube (Four set: 8 pcs.)	1N-ST0608C-01	1 pc.	0.4	φ6 tube, 8pcs

*1 Mass indicates one set.

Specifications

Table: Specifications

Item	Specifications	
	RH-3FRH/6FRH series	RH-12FRH/20FRH series
Material	Urethane	Urethane
Size	Outside diameter: $\phi 4$ x Inside diameter $\phi 2.5$	Outside diameter: $\phi 6$ x Inside diameter $\phi 4$

2

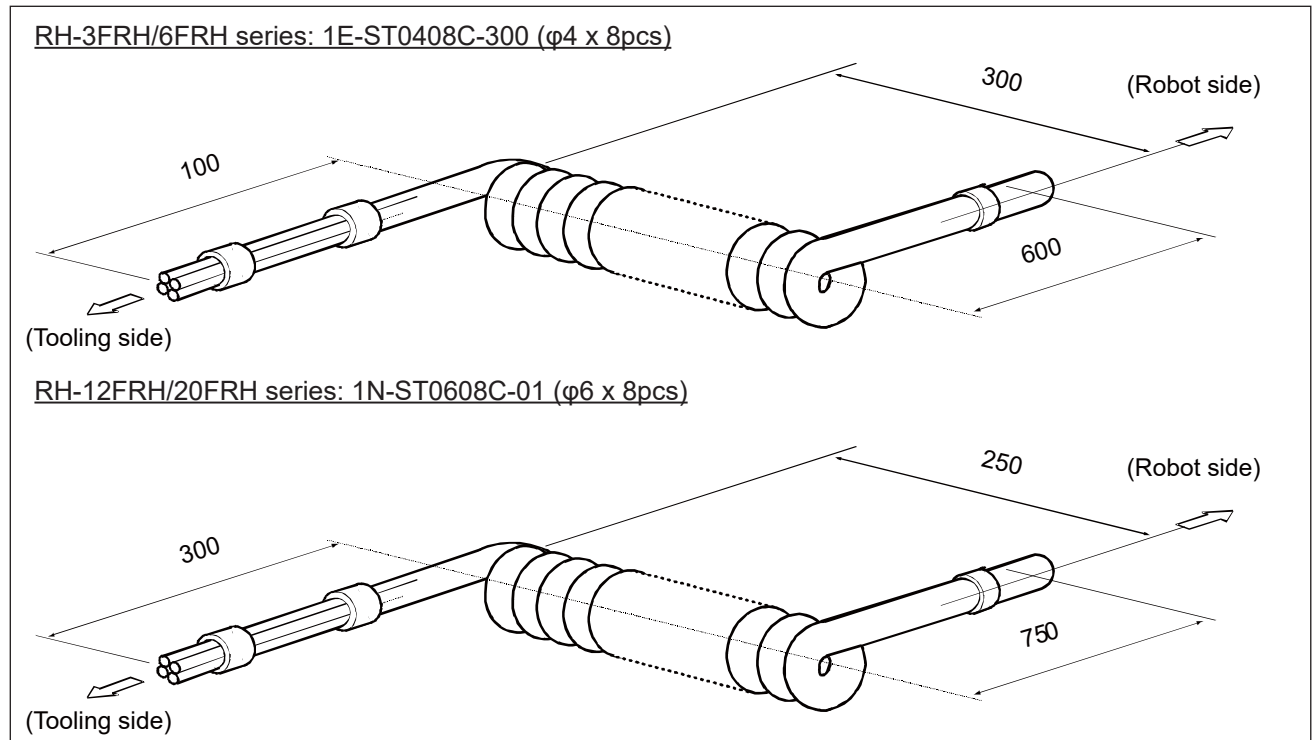

Fig.: Outline dimensional drawing

[Caution]

This option can be installed on clean-type, but its cleanliness is not under warranty.

Hand tube

Order type

●RH-3FRHR series
1E-ST0304S

Outline

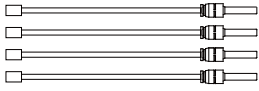

The hand tube is a tube for the pneumatic hand.

Configuration

Table: Configuration equipment

Part name	Type	Qty.	Mass(kg) ^{*1}	Remarks
RH-3FRHR series				
Hand tube (4 pcs.)	1E-ST0304S	1 pc.	0.1	Union (φ4 to φ3): Eight piece attachment (Four of them is installing at shipping) Three rubber sheets, six cable clamp attachment

*1 Mass indicates one set.

Specifications

Table: Specifications

Item	Specifications	
Material	Urethane	One side is with the tape.
Size	Outside diameter: φ3 x Inside diameterφ1.5: 4 pcs.	

*We recommend confirming of the wear and tear and the rub in the cycle of the six months and please prepare as service parts.

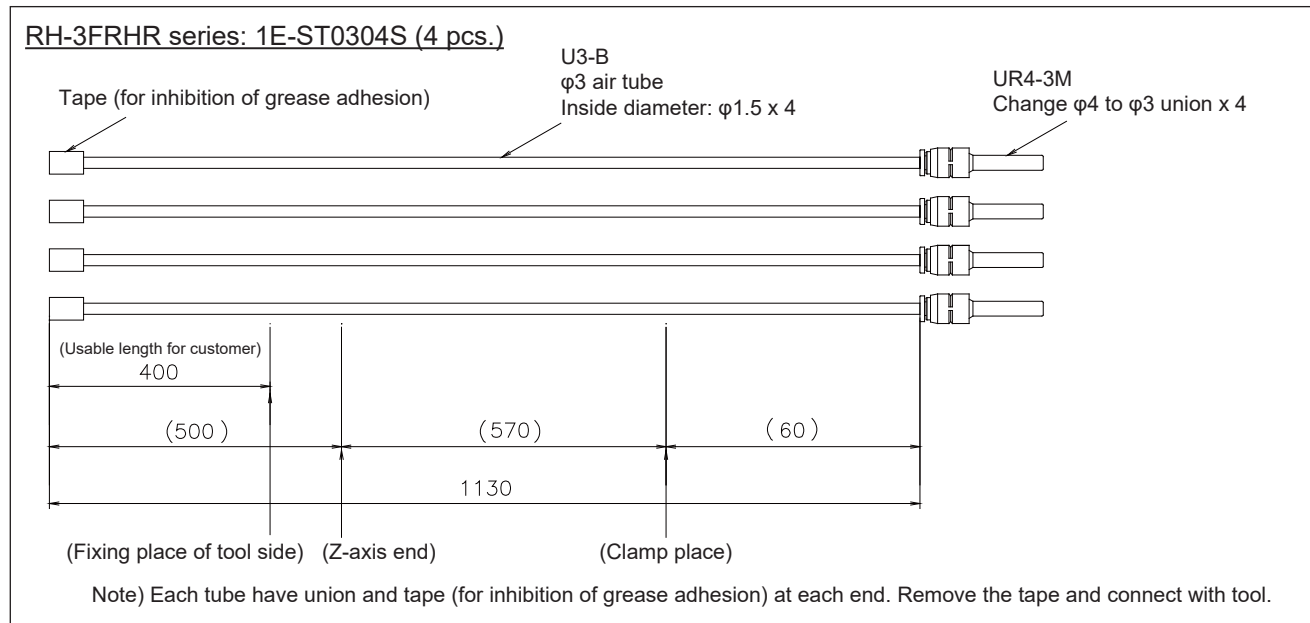

Fig.: Outline dimensional drawing

[Caution]

This option can be installed on clean-type, but its cleanliness is not under warranty.

Internal Wiring/Piping set for hand

Order type

- RH-3FRH series
1F-HS304S-01
- RH-6FH series, 200mm stroke
1F-HS408S-02
- RH-6FRH series, 340mm stroke
1F-HS408S-02
- RH-12FRH/20FRH series, 350mm stroke
1F-HS604S-01
- RH-12FRH/20FRH series, 450mm stroke
1F-HS604S-02

Outline

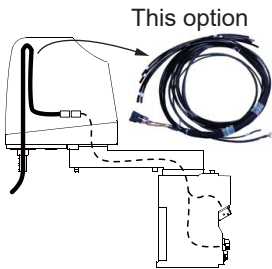

This set, consisting of air hoses and cables, is for feeding air hoses and hand input signal cables from the No. 2 arm through to the shaft tip.

A plate is already attached to be fixed onto the No. 2 arm, and therefore it is easy to ensure the necessary space for wiring and piping.

This can be used together with the separately sold electromagnetic valve set option.

Configuration

Table: Configuration equipment

Item	Type	Qty.	Mass (Kg) ^{*1}	Remarks
RH-3FRH series				
Internal Wiring/Piping set for hand	1F-HS304S-01	1	0.4	The air hose and the cable for hand input signals are contained. The grease (for application to shaft top) and silicon rubber, and cable tie are attached.
RH-6FRH series				
Internal Wiring/Piping set for hand (For 200mm stroke)	1F-HS408S-01	1	0.4	The air hose and the cable for hand input signals are contained.
Internal Wiring/Piping set for hand (For 340mm stroke)	1F-HS408S-02	1	0.4	The grease (for application to shaft top) and silicon rubber, and cable tie are attached.
RH-12FRH/20FRH series				
Internal Wiring/Piping set for hand (For 350mm stroke)	1F-HS604S-01	1	0.4	The air hose and the cable for hand input signals are contained.
Internal Wiring/Piping set for hand (For 450mm stroke)	1F-HS604S-02	1	0.4	The grease (for application to shaft top) and silicon rubber, and cable tie are attached.

*1 Mass indicates one set.

Specification

Table: Specification

Item	Specification	Remarks
RH-3FRH series		
Air hose	φ3 x 4pcs	Both ends are free. Eight reducers (φ3 to φ4) are attached.
Hand input signal cable	AWG #24(0.2mm ²)×6pcs	The robot arm side is connector (HC1, HC2), and one side is free.
Useable length from the shaft end	400mm	The length from the shaft end which can be used of customer.
RH-6FRH series		
Air hose	φ4 x 8pcs	Both ends are free.
Hand input signal cable	Signal	The robot arm side is connector (HC1, HC2), and one side is free.
	Power	
Useable length from the shaft end	380mm	The length from the shaft end which can be used of customer.
RH-12FRH/20FRH series		
Air hose	φ6 x 4pcs	Both ends are free.
Hand input signal cable	Signal	The robot arm side is connector (HC1, HC2), and one side is free.
	Power	
Useable length from the shaft end	420mm	The length from the shaft end which can be used of customer.

[Caution]

This option can be installed on clean-type, but its cleanliness is not under warranty.

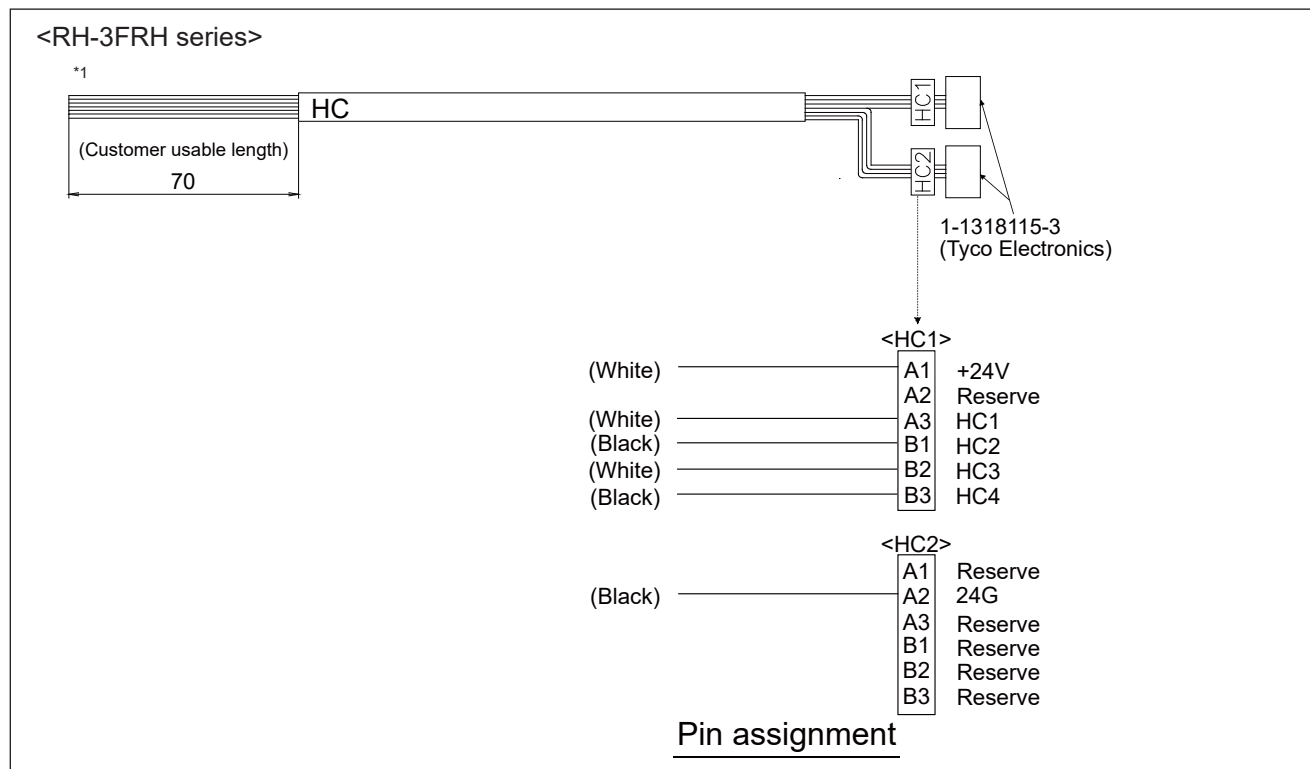

Fig.: Outline dimension drawing and pin assignment (RH-3FRH series)

*1 The signal name is printed at the mark tube.

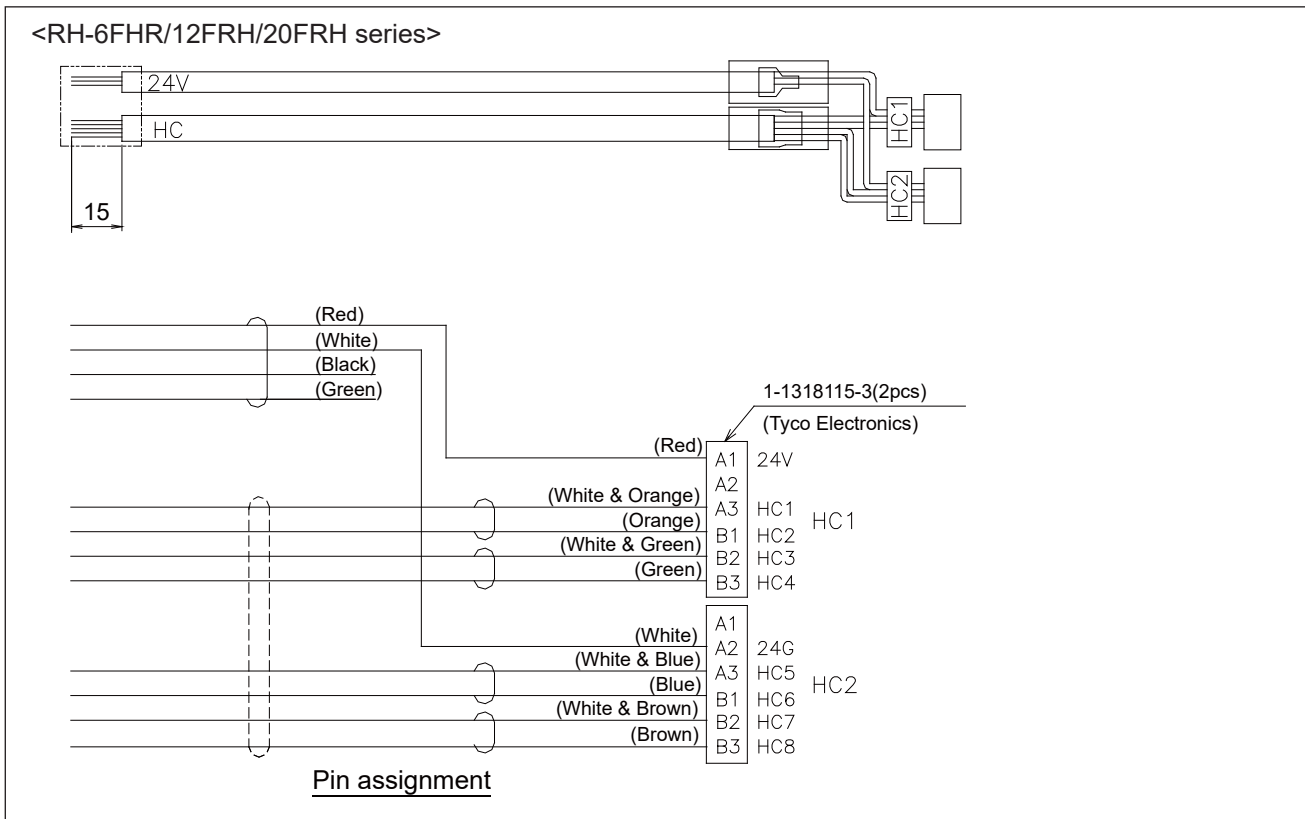

Fig.: Outline dimension drawing and pin assignment (RH-6FHR/12FRH/20FRH series)

External Wiring/Piping box

Order type

●RH-3FRH/6FRH series

1F-UT-BOX

●RH-12FRH/20FRH series

1F-UT-BOX-01

Outline

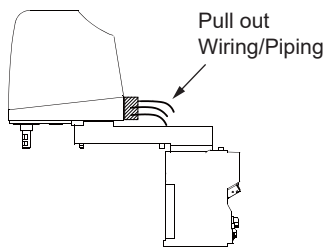

This is a very useful option when removing the air hoses and signal lines from the rear of the No. 2 arm, and pulling hand wiring and piping out to the robot's exterior.

The joint for connects to the external hose is prepared, and the holes which fixes the signal cable to pull out with cable clamp are prepared. Optional hand output cables and hand input cables can be fixed here.

This option can also be used on the oil mist and clean specifications.

Configuration

Table: Configuration equipment



Part name	Type	Qty.	Mass (Kg) ^{*1}	Remarks
RH-3FRH/6FRH series				
External Wiring/Piping box	1F-UT-BOX	1	0.6	Attachments: <ul style="list-style-type: none"> • Air hose (black) φ4-8 • Air hose (black) φ6-1 • Air hose (white) φ6-1 • Installation screw M4x8: 4 (Plain washer) • Cable tie: 4 • Coupling: 2 • Simple spanner for resin nuts
RH-12FRH/20FRH series				
External Wiring/Piping box	1F-UT-BOX-01	1	0.6	Attachments: <ul style="list-style-type: none"> • Air hose (black) φ6-8 • Installation screw M4x12: 4 (Plain washer) • Cable tie: 4 • Simple spanner for resin nuts

*1 Mass indicates one set.

Specification

Table: Specification

Item	Specification	Remarks
RH-3FRH/6FRH series		
Outline	106(W) x 73.6(D) x 72(H)	The coupling is included.
The hole for wiring drawers	$\varnothing 21$ x 4 places	Fix the cable by cable clamp etc.
Coupling	For $\varnothing 4$ air hose x 8pcs	Installed previously
	For $\varnothing 6$ air hose x 2pcs	
RH-12FRH/20FRH series		
Outline	100(W) x 91.9(D) x 70(H)	The coupling is included.
The hole for wiring drawers	$\varnothing 21$ x 4 places	Fix the cable by cable clamp etc.
Coupling	For $\varnothing 6$ air hose x 8pcs	Installed previously

An outside dimension and a component are shown in  Fig.: Outline dimension and configurations (RH-3FRH/6FRH series) or  Fig.: Outline dimension and configurations (RH-12FRH/20FRH series).

<RH-3FRH/6FRH series>

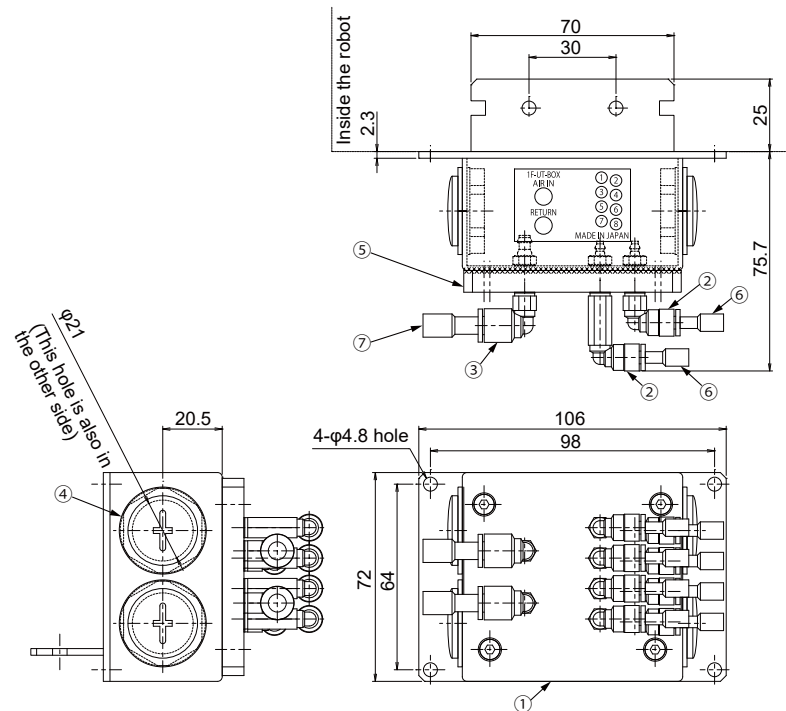

Configuration

Part No.	Part name	Qty.	Specification
①	External Wiring/Piping box housing	1	
②	Quick coupling	8	φ4 (Elbow)
③	Quick coupling	2	φ6 (Elbow)
④	φ21 hole	4	The grommet is attached to each hole. (Two holes are in the right and the left.)
⑤	Manifold block	1	
⑥	Plug	8	Stopper for φ4 quick coupling
⑦	Plug	2	Stopper for φ6 quick coupling
-	Simple spanner for resin nuts	1	Attachment
-	Installation screw	4	Attachment, M4x8 (Plain washer)
-	Air hose	8	Attachment, φ4 (Black)
-	Air hose	1	Attachment, φ6 (Black)
-	Air hose	1	Attachment, φ6 (White)
-	Cable tie	4	Attachment
-	Coupling	2	Attachment, φ6 (Elbow)

Fig.: Outline dimension and configurations (RH-3FRH/6FRH series)

<RH-12FRH/20FRH series>

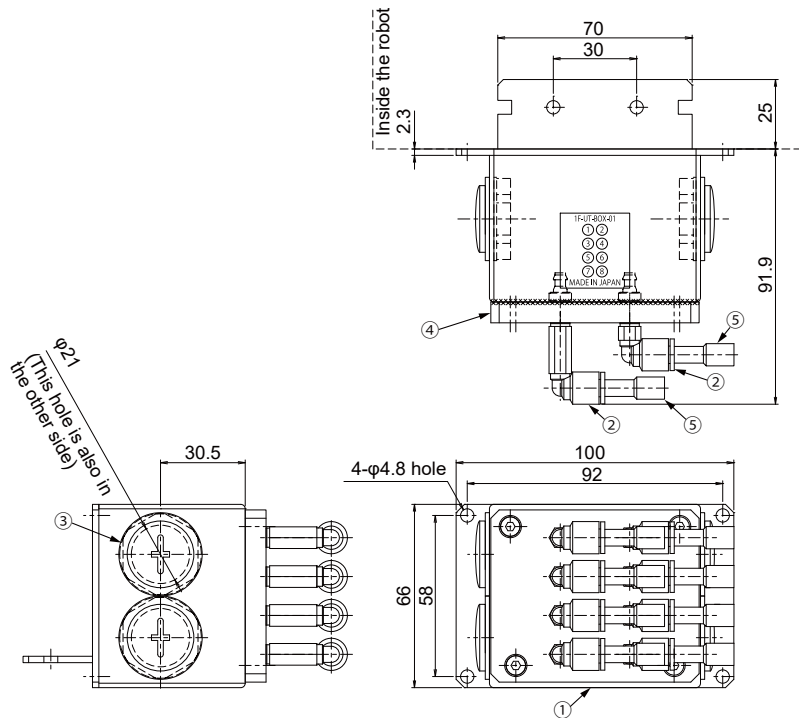

Configuration

Part No.	Part name	Qty.	Specification
①	External Wiring/Piping box housing	1	
②	Quick coupling	8	φ6 (Elbow)
③	φ21 hole	4	The grommet is attached to each hole.
④	Manifold block	1	(Two holes are in the right and the left.)
⑤	Plug	8	Stopper for φ6 quick coupling
-	Simple spanner for resin nuts	1	Attachment
-	Installation screw	4	Attachment, M4x12 (Plain washer)
-	Air hose	8	Attachment, φ6 (Black)
-	Cable tie	4	Attachment

Fig.: Outline dimension and configurations (RH-12FRH/20FRH series)

2.7 About Overhaul

Robots which have been in operation for an extended period of time can suffer from wear and other forms of deterioration. In regard to such robots, we define overhaul as an operation to replace parts running out of specified service life or other parts which have been damaged, so that the robots may be put back in shape for continued use. As a rule of thumb, it is recommended that overhaul be carried out before the total amount of servo-on time reaches the specified time (24,000 hours for the robot arm and 36,000 hours for the controller). However, the degree of the equipment's wear and deterioration presumably varies depending on their operating conditions. Especially for operation with high load and frequency, the maintenance cycle may be shorter. For details on the part selection for replacement and the timing of overhaul, contact your dealer.

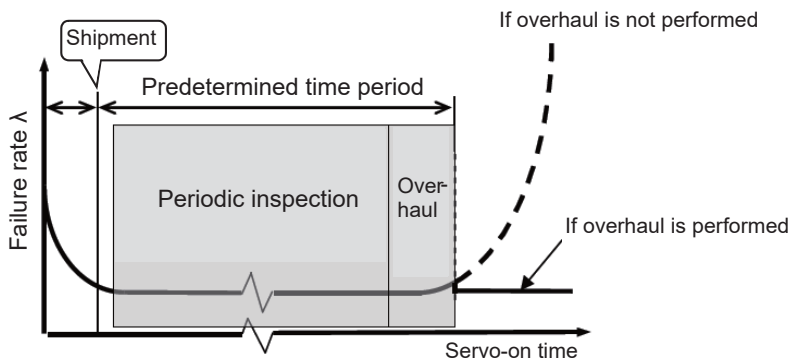

Fig.: Periodic inspection/overhaul periods

2.8 Maintenance parts



A long-term use of industrial robots causes a malfunction due to wear or deterioration of their components, as well as general machines. To prevent such a malfunction and perform smooth operation of the robot for a long term, the regular maintenance, inspection, and replacement of consumable parts are required. Refer to "Maintenance and Inspection" in  RH-FRH Series INSTRUCTION MANUAL ROBOT ARM SETUP & MAINTENANCE (BFP-A3472) for details of the maintenance and inspection. The consumable parts used in the robot arm are shown in  Table: Consumable part list. Purchase these parts from the designated maker or dealer when required. Some Mitsubishi-designated parts differ from the maker's standard parts. Thus, confirm the part name, robot arm and controller serial No. and purchase the parts from the dealer.

Table: Consumable part list

No.	Part name	Type *1	Usage place	Qty.	Supplier
Common parts between robot type					
1	Grease		Reduction gears of each axis	As needed	Mitsubishi Electric
2			Ball screw spline Ball screw Ball spline	As needed	
3	Lithium battery	MR-BAT6V1	Base section	4	
RH-3FRH					
4	Timing belt		J3 axis	1	Mitsubishi Electric
5			J4 axis motor side	1	
6			J4 axis shaft side	1	
RH-6FRH series					
7	Timing belt		J3 axis	1	Mitsubishi Electric
8			J4 axis motor side	1	
9			J4 axis shaft side	1	
RH-12FRH series					
10	Timing belt		J3 axis	1	Mitsubishi Electric
11			J4 axis motor side	1	
12			J4 axis shaft side	1	
RH-20FRH series					
13	Timing belt		J3 axis	1	Mitsubishi Electric
14			J4 axis motor side	1	
15			J4 axis shaft side	1	
RH-3FRHR series					
16	Timing belt		J1 axis	1	Mitsubishi Electric
17			J2 axis	1	
18			J3 axis	1	
19			J4 axis motor side	1	
20			J4 axis shaft side	1	

*1 Confirm the robot arm serial No., and contact the dealer or service branch of Mitsubishi Electric Co., for the type.

3 Controller

3.1 Standard specifications

Basic specifications

CR800-D controller

■ Specifications of CR800-D controller

Item	Unit	Specification	Remarks	
Type		CR800-□HD CR800-03HRD	“□” in type name shows the load (3kg: “03”, 6kg: “06”, 12kg: “12”, 20kg: “20”) of the robot arm. CR800-03HRD controller is for RH-3FRHR only.	
Number of control axis		Simultaneously 4	Additional 8 axes available.	
Memory capacity	Programmed positions	point	39,000	
	No. of steps	step	78,000	
	Number of program		512	
Robot language		MELFA-BASIC V, VI		
Teaching method		Pose teaching method, MDI method *1		
External input and output	Input and output	point	0/0	Max. 256/256 by option
	Dedicated input/output		Assigned with general-purpose input/output	The signal number of "STOP" input signals is fixing.
	Hand open/close input/output	point	8/8	The sink/source type can be switched with parameters.
	Emergency stop input *2	point	1 (duplicated)	*3
	Emergency stop output	point	1 (duplicated)	
	Mode selector switch input *4	point	1 (duplicated)	
	Mode output	point	1 (duplicated)	
	Robot error output	point	1 (duplicated)	
	Additional axis synchronization output	point	1 (duplicated)	
	Door switch input	point	1 (duplicated)	
Ecoder input	Channel	2		
Interface	Additional axis, force sensor interface	Channel	1	SSCNET III/H (Connect with MR-J4-B series)
	Remote input/output	Channel	1	Compatible with Ver. 1.0/2.0
	USB	port	1	Ver. 2.0 HighSpeed device functions only. USB mini-B
				Dedicated T/B port: 100BASE-TX/10BASE-T
	Option slot	slot	2	For option interface
	SD memory card slot	slot	1	For extended memory
	RS-422	port	1	Dedicated T/B port
Power source	Input voltage range	V	Single phase AC 200 to 230	The rate of power-supply voltage fluctuation is within 10%.
	Power capacity	kVA	RH-3FRH series: 0.5 RH-6FRH series: 1.0 RH-12FRH/20FRH series: 1.5 RH-3FRHR series: 1.0	Does not include rush current. *5
	Power supply frequency	Hz	50/60	
Outline dimensions *6	mm	430(W) x 425(D) x 99.5(H)	Excluding protrusions	
Mass	kg	Approx. 12.5		

Item	Unit	Specification	Remarks	
Construction		Self-contained floor type, Opened type. Installation vertically or horizontally	IP20 ^{*7}	
Ambient temperature	In use	°C	0 to 40	Without freeze
	At transport/storage		-15 to +70	
Ambient humidity	In use	%RH	45 to 85	Without dew drops
	At transport/storage		90 or less	
Overvoltage category ^{*8}		II or less		
Pollution level ^{*9}		2 or less		
Altitude	m	1000 or less		
Grounding	Ω	100 or less	100Ω or less (class D grounding) ^{*10}	
Paint color		Dark gray	Equivalent to Munsell: 3.5PB3.2/0.8, PANTONE: 432C	

*1 Pose teaching method: The method to register the current position of the robot arm.

MDI method: The method to register by inputting the numerical value Immediate.

*2 At factory settings, the STO function activated by an external emergency stop input meets the requirements of SIL 2, Category 3, and PL d. The STO function activated by an external emergency stop input meets the requirements of SIL 3, Category 4, and PL e when the parameter setting is changed by referring to  Page 290 Safety diagnosis function (Test pulse diagnosis).

*3 For details on the functions using external input/output signals, always refer to  Page 289 Classification of functions using external input/output signals.

*4 Provide a mode selector switch to change the mode (MANUAL/AUTOMATIC) of the controller. Select the switch that meets the following specifications.

- The switch can be locked in each position of the selected mode.
- The selected switch position can be clearly distinguished from each other.
- Only one mode can be selected at a time.

(Recommended switch model: HA1K-2C2A-2 manufactured by IDEC. The key switch can be locked in each position by removing its key.)

The mode can be changed by other means than the selector switch.

For example, the user can use a mode change program. In the program, provide a means to lock the selected mode with a password.

*5 The power capacity is the recommended value. The power capacity does not include the rush current when the power is turned ON. The power capacity is a guideline and the actual operation is affected by the input power voltage. Use the short circuit breaker which operates by the current leakage under the commercial frequency domain (50-60Hz). If sensitive to the high frequency ingredient, it will become the cause in which below the maximum leak current value carries out the trip.

The following lists the current values of the representative models as a reference.

Robot model	Item	Current [A]	Apparent power[kVA]	Voltage at measurement[V]	
RH-3FRH	At control power ON	0.41	0.09	216.8	
	At servo ON	0.53	0.12	217.0	
	In automatic operation	Effective value	1.98	0.43	217.2
		Peak	4.60	0.99	218.7
RH-6FRH	At control power ON	0.40	0.09	218.1	
	At control power ON	0.59	0.13	217.5	
	In automatic operation	Effective value	2.54	0.53	217.8
		Peak	6.00	1.26	218.3
RH-20FRH	At control power ON	0.44	0.10	215.8	
	At control power ON	0.64	0.14	215.8	
	In automatic operation	Effective value	3.91	0.83	216.0
		Peak	34.00	7.20	216.6
RH-3FRHR	At control power ON	0.39	0.08	216.6	
	At control power ON	0.56	0.12	216.5	
	In automatic operation	Effective value	4.55	0.83	215.8
		Peak	14.50	3.00	216.6

*6 Refer to  Page 205 Outside dimensions for details.

*7 This controller is standard specification. (Refer to  Page 198 Protection specifications and operating supply.)

*8 This indicates the section of the power supply to which the equipment is assumed to be connected between the public electrical power distribution network and the machinery within premises.

Category II applies to equipment for which electrical power is supplied from fixed facilities. The surge voltage withstand level for up to the rated voltage of 300V is 2500V.

- *9 This index indicates the degree to which conductive material is generated in terms of the environment in which the equipment is used. Pollution level 2 is when only non-conductive pollution occurs. A temporary conductivity caused by condensing must be expected occasionally.
- *10 The robot must be grounded by the customer.

■CR800-D controller safety performance

Function	Item	Performance	Remarks	
STO	Safety Level	SIL 3 (IEC 61508:2010)	Performance when: • External emergency stop input when the test pulse diagnosis settings are enabled *1	
		Category 4, PL e (EN ISO 13849-1:2015)		
	Mean time to dangerous failure (MTTFd)	MTTFd ≥ 100 years		
	Diagnostic coverage (DC)	DC = 99%		
	Probability of dangerous failure per hour (PFH) *2	PFH = 1.40×10^{-8} [1/hour]		
	Safety Level	SIL 2 (IEC 61508:2010)		Performance when: • External emergency stop input when the test pulse diagnosis settings are disabled (factory settings) • Door switch input • Mode selector switch input
		Category 3, PL d (EN ISO 13849-1:2015)		
	Mean time to dangerous failure (MTTFd)	MTTFd ≥ 100 years		
Diagnostic coverage (DC)	DC = 90%			
Probability of dangerous failure per hour (PFH) *2	PFH = 1.57×10^{-8} [1/hour]			

*1 To use this product at a performance level of SIL 3, Category 4, PL e, refer to  Page 289 Classification of functions using external input/output signals and set the parameters accordingly.

*2 The robot controller PFH or PFHd (Probability of Dangerous Failure per Hour). The PFH of the emergency stop switch and 3-position enable switch on the teaching pendant is shown in the table below.

Teaching pendant	Switch	B10d [cycle]	N _{op} [cycle/year]	MTTFd [year]	DC [%]	PFH [1/hour]
R32TB	Emergency stop switch	1×10^6	6000	1667	≥ 99	2.47×10^{-8}
	3-position enable switch	1×10^6	6000	1667	≥ 99	2.47×10^{-8}
R56TB	Emergency stop switch	1×10^6	6000	1667	≥ 99	2.47×10^{-8}
	3-position enable switch	7×10^6	6000	11667	60 ≤ DC < 90	1.57×10^{-7}

CR800-R controller

Use the robot CPU unit which connects to CR800-R controller, equipping the base unit of the sequencer of the MELSEC iQ-R series of our company. Specifications such as the power supply and outside dimension of the robot CPU unit are the same as the sequencer's specification. Refer to Fig.: Names of each part of the robot CPU unit (CR800-R controller) (Names of each part), and Fig.: Outside dimensions of robot CPU unit (CR800-R controller) (Outside dimensions).

Although the specification with which the robot CPU unit and the controller (box which mounts the servo amplifier for the robots, the safety circuit, etc.) were put together is shown in Specifications of CR800-R controller, the specification of the controller is mainly described.

Specifications of CR800-R controller

Item	Unit	Specification	Remarks	
Type		CR800-□HR CR800-03HRR	"□" in type name shows the load (3kg: "03", 6kg: "06", 12kg: "12", 20kg: "20") of the robot arm. CR800-03HRR controller is for RH-3FRHR only.	
Number of control axis		Simultaneously 4	Additional 8 axes available.	
Memory capacity	Programmed positions	point	39,000	
	No. of steps	step	78,000	
	Number of program		512	
Robot language		MELFA-BASIC V, VI		
Teaching method		Pose teaching method, MDI method *1		
External input and output	Input and output	point	0/0	Multi-CPU shared device Input 8192/Output 8192 (Max.)
	Dedicated input/output		Assign to the multi-CPU shared device.	
	Hand open/close input/output	point	8/8	The sink/source type can be switched with parameters.
	Emergency stop input *2	point	1 (duplicated)	*3
	Emergency stop output	point	1 (duplicated)	
	Mode selector switch input *4	point	1 (duplicated)	
	Mode output	point	1 (duplicated)	
	Robot error output	point	1 (duplicated)	
	Additional axis synchronization output	point	1 (duplicated)	
Door switch input	point	1 (duplicated)		
Interface	Additional axis, force sensor interface	Channel	1	SSCNET III/H (Connect with MR-J4-B series)
	Remote input/output	Channel	1	Compatible with Ver. 2.0 (safety control)
	Ethernet	port	1	For customer: 1000BASE-T/100BASE-TX/10BASE-T
			1	Dedicated T/B port: 100BASE-TX/10BASE-T
	Option slot	slot	2	Only the function extension card is available.
	SD memory card slot	slot	1	Unusable
	RS-422	port	1	Dedicated T/B port
Power source	Input voltage range	V	Single phase AC 200 to 230	The rate of power-supply voltage fluctuation is within 10%.
	Power capacity	kVA	RH-3FRH series: 0.5 RH-6FRH series: 1.0 RH-12FRH/20FRH series: 1.5 RH-3FRHR series: 1.0	Does not include rush current. *5
	Power supply frequency	Hz	50/60	
Outline dimensions *6	mm	430(W) x 425(D) x 99.5(H)	Excluding protrusions	
Mass	kg	Approx. 12.5		
Construction		Self-contained floor type, Opened type. Installation vertically or horizontally	IP20 *7	
Ambient temperature	In use	°C	0 to 40	Without freeze
	At transport/storage		-15 to +70	

Item	Unit	Specification	Remarks	
Ambient humidity	In use	%RH	45 to 85	Without dew drops
	At transport/storage		90 or less	
Overvoltage category ^{*8}		II or less		
Pollution level ^{*9}		2 or less		
Altitude	m	1000 or less		
Grounding	Ω	100 or less	100Ωor less (class D grounding) ^{*10}	
Paint color		Dark gray	Equivalent to Munsell: 3.5PB3.2/0.8, PANTONE: 432C	

- *1 Pose teaching method: The method to register the current position of the robot arm.
MDI method: The method to register by inputting the numerical value Immediate.
- *2 At factory settings, the STO function activated by an external emergency stop input meets the requirements of SIL 2, Category 3, and PL d. The STO function activated by an external emergency stop input meets the requirements of SIL 3, Category 4, and PL e when the parameter setting is changed by referring to Page 290 Safety diagnosis function (Test pulse diagnosis).
- *3 For details on the functions using external input/output signals, always refer to Page 289 Classification of functions using external input/output signals.
- *4 Provide a mode selector switch to change the mode (MANUAL/AUTOMATIC) of the controller. Select the switch that meets the following specifications.
 - The switch can be locked in each position of the selected mode.
 - The selected switch position can be clearly distinguished from each other.
 - Only one mode can be selected at a time.
 (Recommended switch model: HA1K-2C2A-2 manufactured by IDEC. The key switch can be locked in each position by removing its key.)
 The mode can be changed by other means than the selector switch.
 For example, the user can use a mode change program. In the program, provide a means to lock the selected mode with a password.
- *5 The power capacity is the recommended value. The power capacity does not include the rush current when the power is turned ON. The power capacity is a guideline and the actual operation is affected by the input power voltage. Use the short circuit breaker which operates by the current leakage under the commercial frequency domain (50-60Hz). If sensitive to the high frequency ingredient, it will become the cause in which below the maximum leak current value carries out the trip.
 The following lists the current values of the representative models as a reference.

Robot model	Item	Current [A]	Apparent power[kVA]	Voltage at measurement[V]	
RH-3FRH	At control power ON	0.41	0.09	216.8	
	At servo ON	0.53	0.12	217.0	
	In automatic operation	Effective value	1.98	0.43	217.2
		Peak	4.60	0.99	218.7
RH-6FRH	At control power ON	0.40	0.09	218.1	
	At control power ON	0.59	0.13	217.5	
	In automatic operation	Effective value	2.54	0.53	217.8
		Peak	6.00	1.26	218.3
RH-20FRH	At control power ON	0.44	0.10	215.8	
	At control power ON	0.64	0.14	215.8	
	In automatic operation	Effective value	3.91	0.83	216.0
		Peak	34.00	7.20	216.6
RH-3FRHR	At control power ON	0.39	0.08	216.6	
	At control power ON	0.56	0.12	216.5	
	In automatic operation	Effective value	4.55	0.83	215.8
		Peak	14.50	3.00	216.6

- *6 Refer to Page 205 Outside dimensions for details.
- *7 This controller is standard specification. (Refer to Page 198 Protection specifications and operating supply.)
- *8 This indicates the section of the power supply to which the equipment is assumed to be connected between the public electrical power distribution network and the machinery within premises.
 Category II applies to equipment for which electrical power is supplied from fixed facilities. The surge voltage withstand level for up to the rated voltage of 300V is 2500V.
- *9 This index indicates the degree to which conductive material is generated in terms of the environment in which the equipment is used. Pollution level 2 is when only non-conductive pollution occurs. A temporary conductivity caused by condensing must be expected occasionally.
- *10 The robot must be grounded by the customer.

■ Robot CPU unit (CR800-R controller) standard specification

Item		Unit	Specification	Remarks
Type			R16RTCPU	
Interface	Additional axis interface	port	1	
Power source	Power capacity (DC5V)	A	1.7	
Outline dimension		mm	27.8(W)×110(D)×106(H)	
Mass		kg	0.3	
Ambient temperature	In use	°C	0 to 55	Without freeze
	At transport/storage		-15 to +70	
Ambient humidity	In use	%RH	5 to 95	Without dew drops
	At transport/storage		90 or less	

■ CR800-R controller safety performance

Function	Item	Performance	Remarks	
STO	Safety Level	SIL 3 (IEC 61508:2010)	Performance when: • External emergency stop input when the test pulse diagnosis settings are enabled *1	
		Category 4, PL e (EN ISO 13849-1:2015)		
	Mean time to dangerous failure (MTTFd)	MTTFd ≥ 100 years		
	Diagnostic coverage (DC)	DC = 99%		
	Probability of dangerous failure per hour (PFH) *2	PFH = 1.40 × 10 ⁻⁸ [1/hour]		
	Safety Level	SIL 2 (IEC 61508:2010)		Performance when: • External emergency stop input when the test pulse diagnosis settings are disabled (factory settings) • Door switch input • Mode selector switch input
		Category 3, PL d (EN ISO 13849-1:2015)		
	Mean time to dangerous failure (MTTFd)	MTTFd ≥ 100 years		
Diagnostic coverage (DC)	DC = 90%			
Probability of dangerous failure per hour (PFH) *2	PFH = 1.57 × 10 ⁻⁸ [1/hour]			

*1 To use this product at a performance level of SIL 3, Category 4, PL e, refer to  Page 289 Classification of functions using external input/output signals and set the parameters accordingly.

*2 The robot controller PFH or PFHd (Probability of Dangerous Failure per Hour). The PFH of the emergency stop switch and 3-position enable switch on the teaching pendant is shown in the table below.

Teaching pendant	Switch	B10d [cycle]	N _{op} [cycle/year]	MTTFd [year]	DC [%]	PFH [1/hour]
R32TB	Emergency stop switch	1×10 ⁶	6000	1667	≥ 99	2.47×10 ⁻⁸
	3-position enable switch	1×10 ⁶	6000	1667	≥ 99	2.47×10 ⁻⁸
R56TB	Emergency stop switch	1×10 ⁶	6000	1667	≥ 99	2.47×10 ⁻⁸
	3-position enable switch	7×10 ⁶	6000	11667	60 ≤ DC < 90	1.57×10 ⁻⁷

CR800-Q controller



Use the robot CPU unit which connects to CR800-Q controller, equipping the base unit of the sequencer of the MELSEC-Q series of our company. Specifications such as the power supply and outside dimension of the robot CPU unit are the same as the sequencer's specification. Refer to Fig.: Names of each part of the robot CPU unit (CR800-Q controller) (Names of each part), and Fig.: Outside dimensions of robot CPU unit (CR800-Q controller) (Outside dimensions).

Although the specification with which the robot CPU unit and the controller (box which mounts the servo amplifier for the robots, the safety circuit, etc.) were put together is shown in Page 195 Specifications of CR800-Q controller, the specification of the controller is mainly described.



■Specifications of CR800-Q controller

Item	Unit	Specification	Remarks		
Type		CR800-□HQ CR800-03HRQ	“□” in type name shows the load (3kg: “03”, 6kg: “06”, 12kg: “12”, 20kg: “20”) of the robot arm. CR800-03HRQ controller is for RH-3FRHR only.		
Number of control axis		Simultaneously 4	Additional 8 axes available.		
Memory capacity	Programmed positions	point	26,000		
	No. of steps	step	52,000		
	Number of program		512		
Robot language		MELFA-BASIC V, VI			
Teaching method		Pose teaching method, MDI method *1			
External input and output	Input and output	point	0/0	Multi-CPU shared device Input 8192/Output 8192 (Max.)	
		Dedicated input/output	Assign to the multi-CPU shared device.		
	Hand open/close input/output	point	8/8		The sink/source type can be switched with parameters.
	Emergency stop input *2	point	1 (duplicated)		*3
	Emergency stop output	point	1 (duplicated)		
	Mode selector switch input *4	point	1 (duplicated)		
	Mode output	point	1 (duplicated)		
	Robot error output	point	1 (duplicated)		
	Additional axis synchronization output	point	1 (duplicated)		
Door switch input	point	1 (duplicated)			
Interface	Additional axis, force sensor interface	Channel	1	SSCNET III/H (Connect with MR-J4-B series)	
	Remote input/output	Channel	1	Compatible with Ver. 2.0 (safety control)	
	Ethernet	port	1	For customer: 1000BASE-T/100BASE-TX/10BASE-T	
			1	Dedicated T/B port: 100BASE-TX/10BASE-T	
	Option slot	slot	2	Only the function extension card is available.	
	SD memory card slot	slot	1	Unusable	
RS-422	port	1	Dedicated T/B port		
Power source	Input voltage range	V	Single phase AC 200 to 230	The rate of power-supply voltage fluctuation is within 10%.	
	Power capacity	kVA	RH-3FRH series: 0.5 RH-6FRH series: 1.0 RH-12FRH/20FRH series: 1.5 RH-3FRHR series: 1.0	Does not include rush current. *5	
	Power supply frequency	Hz	50/60		
Outline dimensions *6	mm	430(W) x 425(D) x 99.5(H)	Excluding protrusions		
Mass	kg	Approx. 12.5			
Construction		Self-contained floor type, Opened type. Installation vertically or horizontally	IP20 *7		
Ambient temperature	In use	°C	0 to 40	Without freeze	
	At transport/storage		-15 to +70		

Item	Unit	Specification	Remarks	
Ambient humidity	In use	%RH	45 to 85	Without dew drops
	At transport/storage		90 or less	
Overvoltage category *8		II or less		
Pollution level *9		2 or less		
Altitude	m	1000 or less		
Grounding	Ω	100 or less	100Ω or less (class D grounding) *10	
Paint color		Dark gray	Equivalent to Munsell: 3.5PB3.2/0.8, PANTONE: 432C	

- *1 Pose teaching method: The method to register the current position of the robot arm.
MDI method: The method to register by inputting the numerical value Immediate.
- *2 At factory settings, the STO function activated by an external emergency stop input meets the requirements of SIL 2, Category 3, and PL d. The STO function activated by an external emergency stop input meets the requirements of SIL 3, Category 4, and PL e when the parameter setting is changed by referring to  Page 290 Safety diagnosis function (Test pulse diagnosis).
- *3 For details on the functions using external input/output signals, always refer to  Page 289 Classification of functions using external input/output signals.
- *4 Provide a mode selector switch to change the mode (MANUAL/AUTOMATIC) of the controller. Select the switch that meets the following specifications.
- The switch can be locked in each position of the selected mode.
 - The selected switch position can be clearly distinguished from each other.
 - Only one mode can be selected at a time.
- (Recommended switch model: HA1K-2C2A-2 manufactured by IDEC. The key switch can be locked in each position by removing its key.)
The mode can be changed by other means than the selector switch.
For example, the user can use a mode change program. In the program, provide a means to lock the selected mode with a password.
- *5 The power capacity is the recommended value. The power capacity does not include the rush current when the power is turned ON. The power capacity is a guideline and the actual operation is affected by the input power voltage. Use the short circuit breaker which operates by the current leakage under the commercial frequency domain (50-60Hz). If sensitive to the high frequency ingredient, it will become the cause in which below the maximum leak current value carries out the trip.
The following lists the current values of the representative models as a reference.

Robot model	Item	Current [A]	Apparent power[kVA]	Voltage at measurement[V]	
RH-3FRH	At control power ON	0.41	0.09	216.8	
	At servo ON	0.53	0.12	217.0	
	In automatic operation	Effective value	1.98	0.43	217.2
		Peak	4.60	0.99	218.7
RH-6FRH	At control power ON	0.40	0.09	218.1	
	At control power ON	0.59	0.13	217.5	
	In automatic operation	Effective value	2.54	0.53	217.8
		Peak	6.00	1.26	218.3
RH-20FRH	At control power ON	0.44	0.10	215.8	
	At control power ON	0.64	0.14	215.8	
	In automatic operation	Effective value	3.91	0.83	216.0
		Peak	34.00	7.20	216.6
RH-3FRHR	At control power ON	0.39	0.08	216.6	
	At control power ON	0.56	0.12	216.5	
	In automatic operation	Effective value	4.55	0.83	215.8
		Peak	14.50	3.00	216.6

- *6 Refer to  Page 205 Outside dimensions for details.
- *7 This controller is standard specification. (Refer to  Page 198 Protection specifications and operating supply.)
- *8 This indicates the section of the power supply to which the equipment is assumed to be connected between the public electrical power distribution network and the machinery within premises.
Category II applies to equipment for which electrical power is supplied from fixed facilities. The surge voltage withstand level for up to the rated voltage of 300V is 2500V.
- *9 This index indicates the degree to which conductive material is generated in terms of the environment in which the equipment is used. Pollution level 2 is when only non-conductive pollution occurs. A temporary conductivity caused by condensing must be expected occasionally.
- *10 The robot must be grounded by the customer.

■ Robot CPU unit (CR800-Q controller) standard specification

Item	Unit	Specification	Remarks	
Type		Q172DSRCPU		
Interface	Additional axis interface	port	1	
Power source	Power capacity (DC5V)	A	1.44	
Outline dimension	mm	27.4(W)×120.3(D)×120.5(H)		
Mass	kg	0.38		
Ambient temperature	In use	°C	0 to 55	Without freeze
	At transport/storage		-25 to +75	
Ambient humidity	In use	%RH	5 to 95	Without dew drops
	At transport/storage		5 to 95	

■ CR800-Q controller safety performance

Function	Item	Performance	Remarks	
STO	Safety Level	SIL 3 (IEC 61508:2010)	Performance when: • External emergency stop input when the test pulse diagnosis settings are enabled *1	
		Category 4, PL e (EN ISO 13849-1:2015)		
	Mean time to dangerous failure (MTTFd)	MTTFd ≥ 100 years		
	Diagnostic coverage (DC)	DC = 99%		
	Probability of dangerous failure per hour (PFH) *2	PFH = 1.40×10^{-8} [1/hour]		
	Safety Level	SIL 2 (IEC 61508:2010)		Performance when: • External emergency stop input when the test pulse diagnosis settings are disabled (factory settings) • Door switch input • Mode selector switch input
		Category 3, PL d (EN ISO 13849-1:2015)		
	Mean time to dangerous failure (MTTFd)	MTTFd ≥ 100 years		
Diagnostic coverage (DC)	DC = 90%			
Probability of dangerous failure per hour (PFH) *2	PFH = 1.57×10^{-8} [1/hour]			

*1 To use this product at a performance level of SIL 3, Category 4, PL e, refer to  Page 289 Classification of functions using external input/output signals and set the parameters accordingly.

*2 The robot controller PFH or PFHd (Probability of Dangerous Failure per Hour). The PFH of the emergency stop switch and 3-position enable switch on the teaching pendant is shown in the table below.

Teaching pendant	Switch	B10d [cycle]	N _{op} [cycle/year]	MTTFd [year]	DC [%]	PFH [1/hour]
R32TB	Emergency stop switch	1×10^6	6000	1667	≥ 99	2.47×10^{-8}
	3-position enable switch	1×10^6	6000	1667	≥ 99	2.47×10^{-8}
R56TB	Emergency stop switch	1×10^6	6000	1667	≥ 99	2.47×10^{-8}
	3-position enable switch	7×10^6	6000	11667	60 ≤ DC < 90	1.57×10^{-7}

Protection specifications and operating supply

Protection specifications

A protection method complying with the IEC Standard IP20 (Opened type) is adopted for CR800 controller.

The IEC IP symbols refer only to the degree of protection between the solid and the fluids, and don't indicated that any special protection has been constructed for the prevention against oil and water.

[Information]

•The IEC IP20

It indicates the protective structure that prevents an iron ball $12^{+0.05}_0 0+0.05\text{mm}$ diameter, which is being pressed with the power of $3.1 \text{ kg} \pm 10\%$, from going through the opening in the outer sheath of the supplied equipment.

Operating supply

The controller is supposed to be installed and used in the customer's system. Supply the primary power of the controller from the system. In addition, provide a safety device (ex. earth leakage breaker) that can shut off the power of the controller in the customer's system. When using an earth leakage breaker as a safety device, select a product with the highest sensitivity possible referring to the specifications in the table below.

Item	Unit	Specification
Rated voltage	V	AC200 to 230
Rated sensitivity current	mA	30 or more, but as low as possible
Rated current	A	10 or more, but as low as possible

To ensure that the earth leakage breaker used with the CR800 controller meets the requirements of the shut-off time defined in EN 60364-4-41, set the fault loop impedance of the customer wiring section to the value shown below.

For TN system *1

Item	Unit	Specification	Remarks
CB, CP, NFB	Model name	—	NV30FAU-2P-10A-AC100-240V-30mA
	Rated current	A	10
Input voltage range	V	200 to 230 VAC	—
Maximum permissible fault loop impedance	mΩ	284.9	*2

For TT system *1

Item	Unit	Specification	Remarks
Earth leakage breaker *3 *4	Model name	—	NV30FAU-2P-10A-AC100-240V-30mA
	Rated current	A	10
	Rated sensed current (IΔn)	mA	30
Input voltage range	V	200 to 230 VAC	—
Maximum permissible fault loop impedance	Ω	1199	*2

*1 It indicates the grounding system type.

*2 Check that the fault loop impedance of the customer wiring section is equal to or less than the value shown in the table. This value does not include the fault loop impedance of the controller.

*3 For TT system, the rated sensed current and maximum permissible fault loop impedance may be specified by the authorities. Follow the instructions of the authorities.

*4 For TT system, use a Type B earth leakage breaker as required.

Refer to the section  Page 283 Working environment for details on the working environment.

3.2 Names of each part

Controller

Controller front

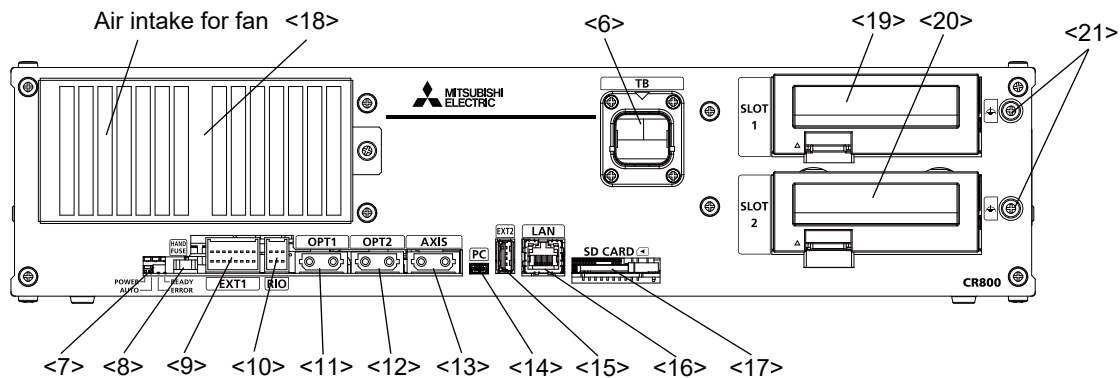

Controller rear

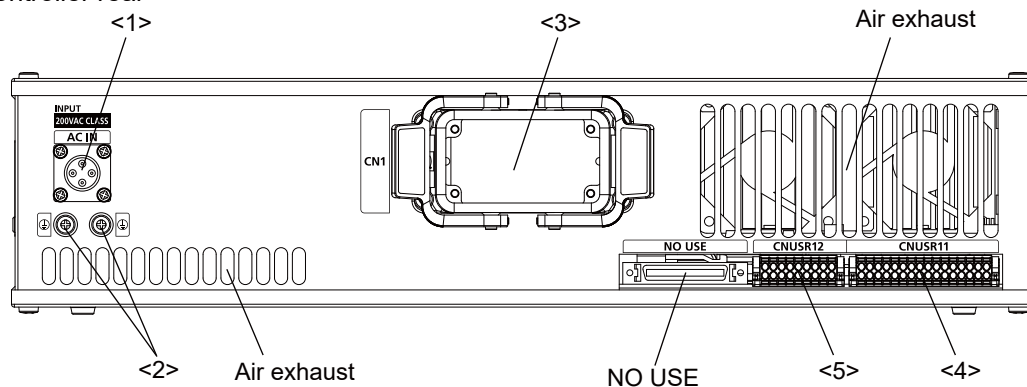

Fig.: Names of controller parts

<1> ACIN connector

Supplied ACIN cable connector (input voltage: AC200V).

Refer to [CR800 Controller Instruction Manual/Controller Setup, Basic Operation, and Maintenance \(BFP-A3476\)](#) for details on the connection method.

Number of phase	ACIN cable
Single phase	<p>Terminal: M5, cable length: 3m</p>

<2> PE terminal

Terminals for grounding (M4 screw x 2).

<3> CN1 cable

Machine cable connector.

<4> <5> CNUSR connector

Robot I/O cable connectors.

<4>: CNUSR11, <5>: CNUSR12

Refer to [CR800 Controller INSTRUCTION MANUAL Controller setup, basic operation, and maintenance \(BFP-A3476\)](#) for the connection method and the further description of pin assignment.

<6> TB connector

Dedicated connector for connecting T/B.

<7> LED

Four LEDs indicating the controller status.

LED	Details
POWER	Indicates the control power status. On: Control power ON Off: Control power OFF
AUTO	Indicates the controller mode. On: AUTOMATIC mode Off: MANUAL mode
ERROR	Indicates the error status. On: Error occurred. Rapid flashing: High-level error occurred. Off: Normal operation
READY	Indicates the operation status. On: ON (ready) Slow flashing: During operation Rapid flashing: Operation suspended.

<8> HAND FUSE

Fuse for the hand.

<9> EXT1

Connector for releasing the brake in an emergency.

For details on the method of releasing the brake in an emergency, refer to  RH-FRH Series INSTRUCTION MANUAL ROBOT ARM SETUP & MAINTENANCE (BFP-A3472).

<10> RIO

Parallel I/O extension connector.

<11> OPT1

Connector for communication with the robot CPU. This connector cannot be used in CR800-D controller.

<12> OPT2

Unused.

<13> AXIS

Connector for additional axis connection.

<14> PC

Connector for communication with a personal computer. This connector cannot be used in CR800-R/CR800-Q controller.

<15> EXT2

Connector for function extension. This connector cannot be used in CR800-R/CR800-Q controller.

<16> LAN

Connector for Ethernet communication. This connector cannot be used in CR800-R/CR800-Q controller.

<17> SD CARD

SD memory card slot. This connector cannot be used in CR800-R/CR800-Q controller.

<18> Filter cover

Dustproof dust filter cover. An air filter is provided inside the filter cover.

<19> <20> Option slot

Option card slots (must be covered when not used).

<19> SLOT1, <20> SLOT2

<21> FG terminal

Option card cable terminals for grounding (M4 screw x 2).

CAUTION

Use the network equipments (personal computer, USB hub, LAN hub, etc) confirmed by manufacturer. The thing unsuitable for the FA environment (related with conformity, temperature or noise) exists in the equipments connected to USB. When using network equipment, measures against the noise, such as measures against EMI and the addition of the ferrite core, may be necessary. Please fully confirm the operation by customer. Guarantee and maintenance of the equipment on the market (usual office automation equipment) cannot be performed.

Robot CPU unit

CR800-R controller

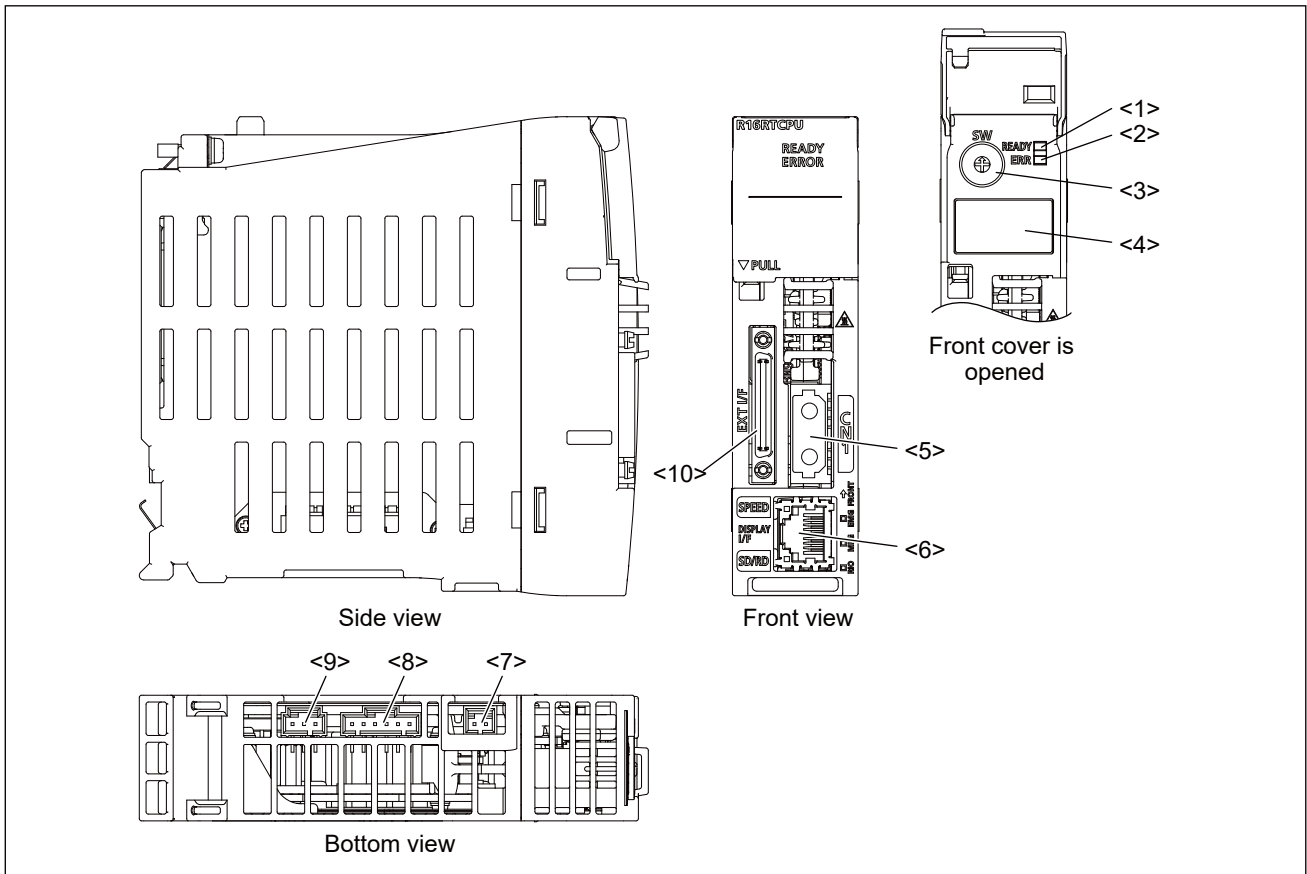

Fig.: Names of each part of the robot CPU unit (CR800-R controller)

<1> <2> LED

Indicators for the operation status and the error status of the robot CPU.

READY LED	ERROR LED	CPU status
OFF	OFF	Power is off or a hardware error occurred.
Flashing	OFF	During initialization.
ON	OFF	Normal operation.
ON	Flashing	Moderate error occurred.
OFF	ON/flashing	Critical error occurred.

<3> Rotary switch

Provided for maintenance. Always set it as "0."

<4>Dot matrix LED

3-digit display indicating the operation status and error information

<5> CN1 connector

Connect the SSCNET III cable between the OPT1 connector on the controller and this connector.

<6>Network connector

Connector for Ethernet communication.

<7> EMG connector

Unused.

<8> MPG connector

Unused.

<9> RIO connector

Unused.

<10>EXT I/F

Unused.

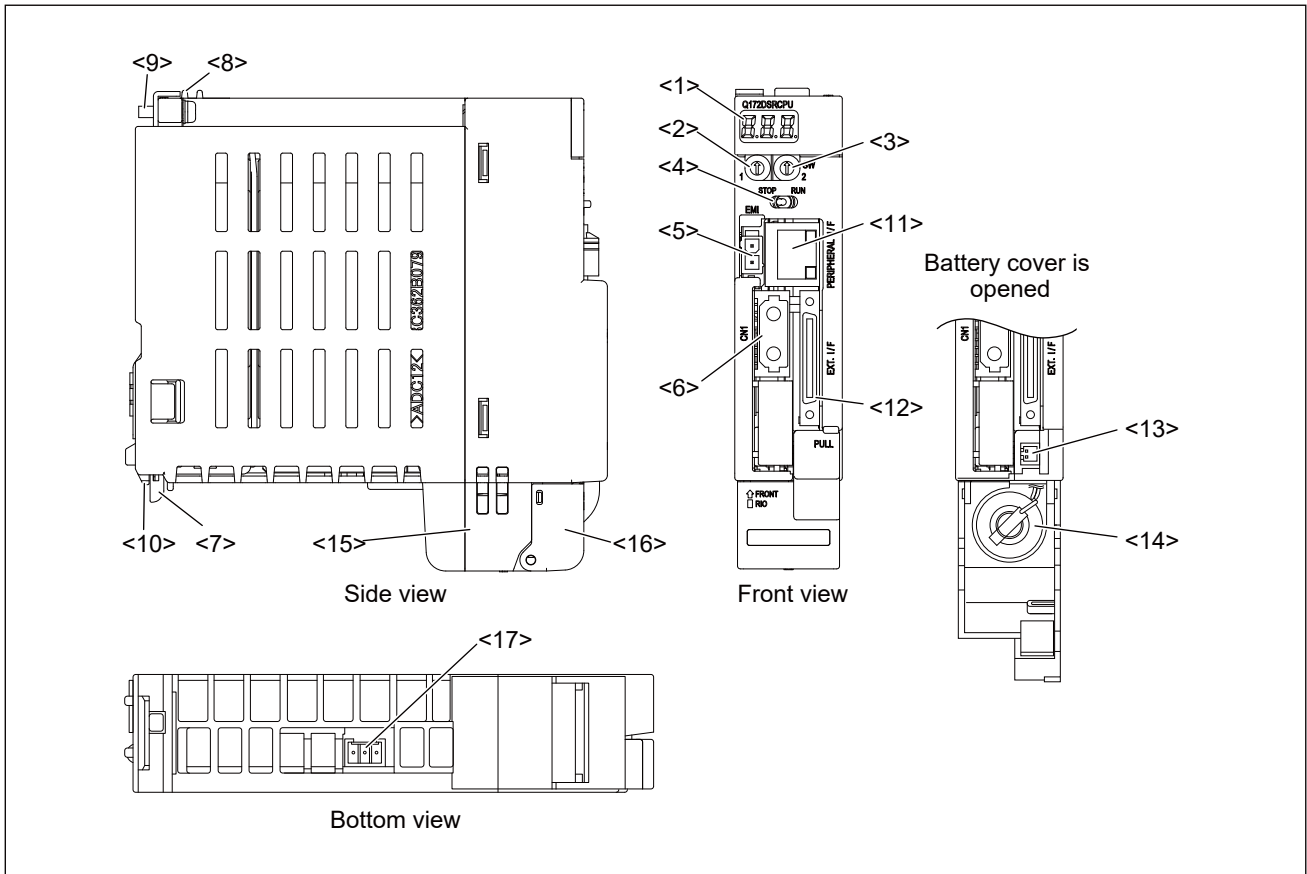

Fig.: Names of each part of the robot CPU unit (CR800-Q controller)

<1> Seven segments LED

Indicates operational status and error information.

<2> Rotary switch (SW1)

Set up operation mode. Always set it as "0."

<3> Rotary switch (SW2)

Set up operation mode. Always set it as "0."

<4> RUN/STOP switch

Unused.

<5> Emergency stop input (EMI)

Unused.

<6> CN1 connector *1

Connect the SSCNET III cable to this connector and the OPT1 connector on the controller. (Connection for robot servo amplifiers)

<7> Lever for unit installation

Use this lever, when installing the unit in the base unit.

<8> Hook for unit fixing *2

The hook which fixes the unit to the base unit (For the support at installation)

<9> Unit fixing screw

The screw for fixing to the base unit (M3×13)

<10> The projection for unit fixing

The projection for fixing to the base unit

<11> PERIPHERAL I/F connector

Connector for Ethernet communication.

<12> EXT I/F connector

Unused.

<13> Battery connector

The connector for connection with battery.

<14> Battery^{*3}

Battery (Q6BAT) for storing data.

<15> Battery holder

Compartment for the battery.

<16> Battery cover

Battery holder cover.

<17> RIO connector

Unused.

- *1 Please store in the duct or fix the cable section near robot CPU with the bunch wire rod so that prudence of the cable is not applied to the connector section.
- *2 It is equipment for the support when installing the unit in the basic base unit. Please be sure to fix the unit to the basic base unit with the attached fixing screw.
- *3 Please be sure to use the external battery. Unless the battery cable is connected surely, the program in SRAM with a built-in robot CPU, the parameter, origin position data, etc. are not held.

3.3 Outside dimensions/Installation dimensions

Outside dimensions

Controller

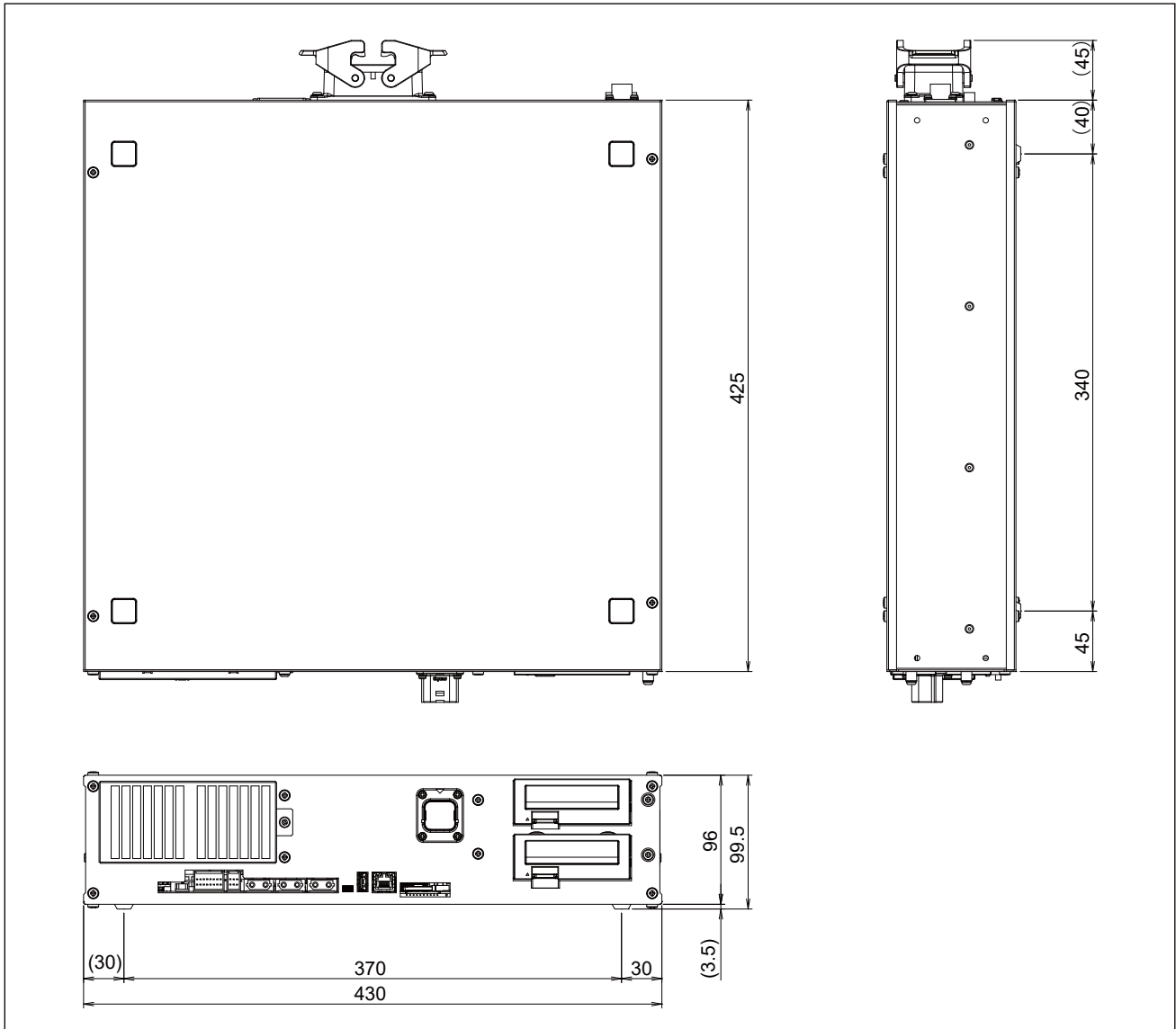

Fig.: Outside dimensions of controller

Robot CPU unit

■CR800-R controller

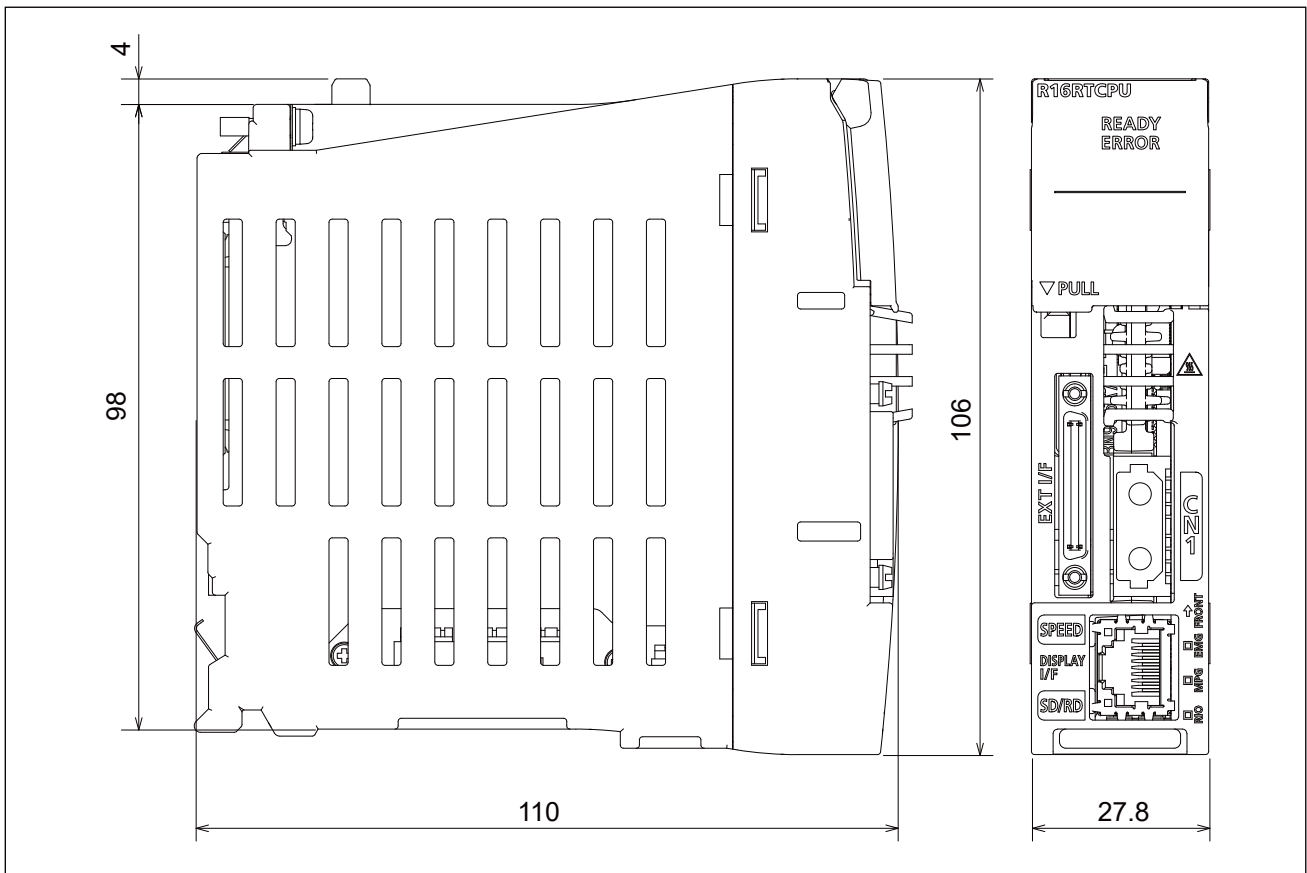

Fig.: Outside dimensions of robot CPU unit (CR800-R controller)

■CR800-Q controller

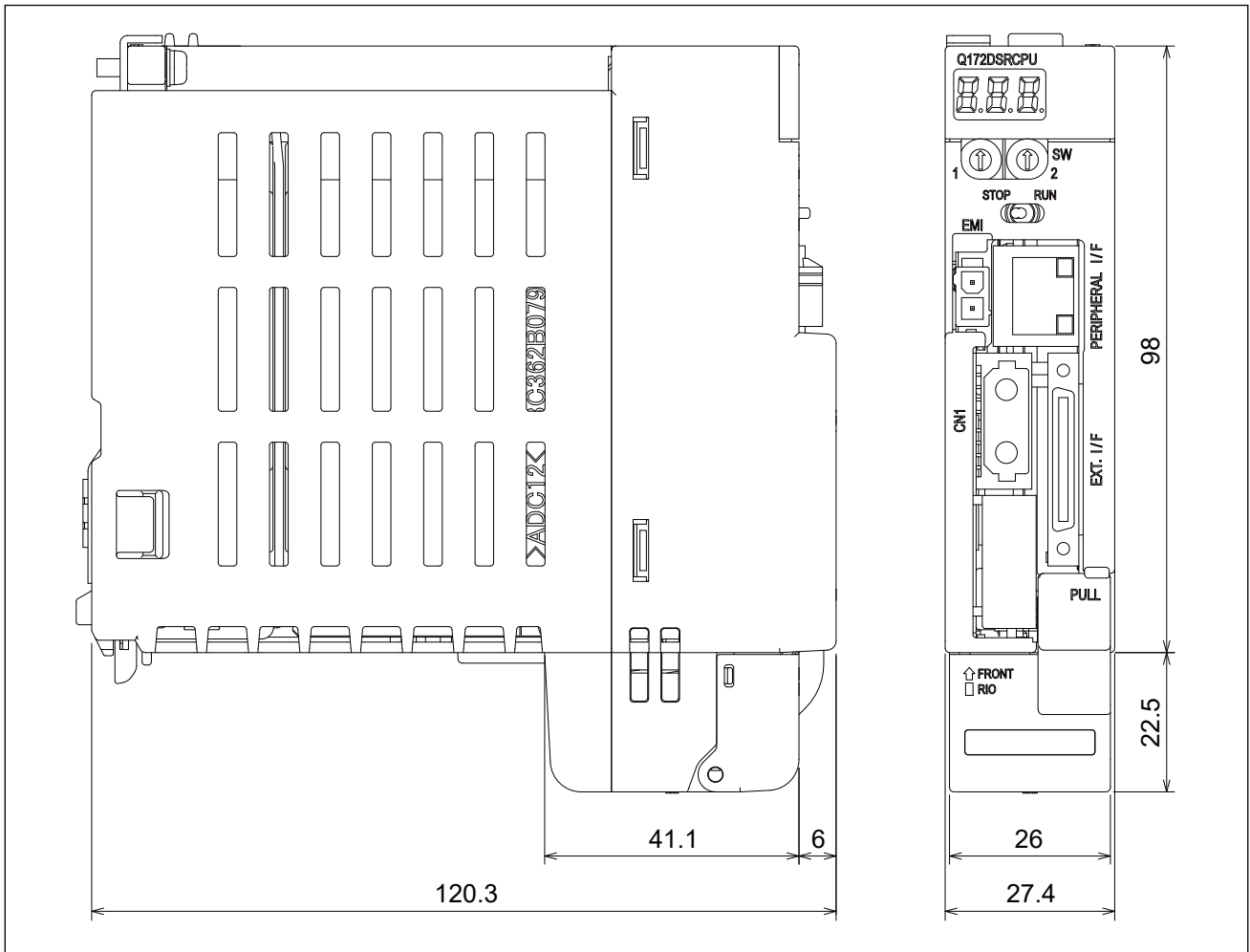

Fig.: Outside dimensions of robot CPU unit (CR800-Q controller)

Installation dimensions

Controller

The following figures show the dimensions required installing the controller.

For the placement of the controller on its side (the horizontal installation), two stacks is permitted.

Horizontal installation

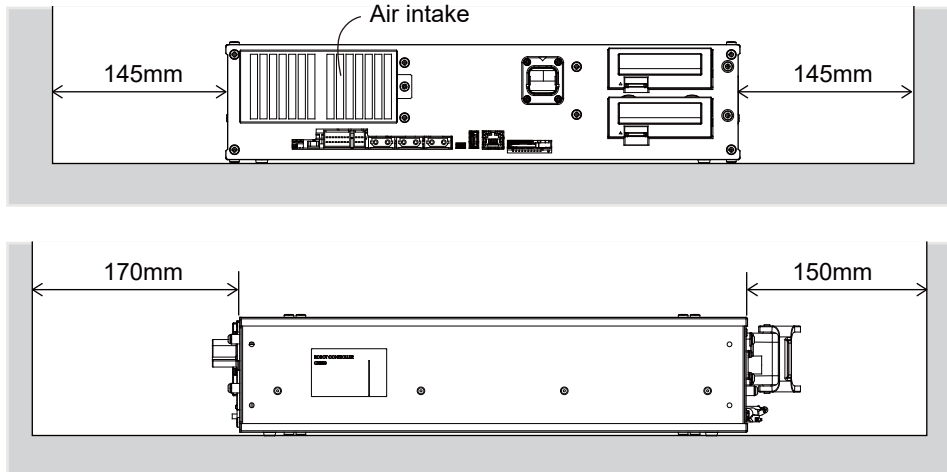

Vertical installation

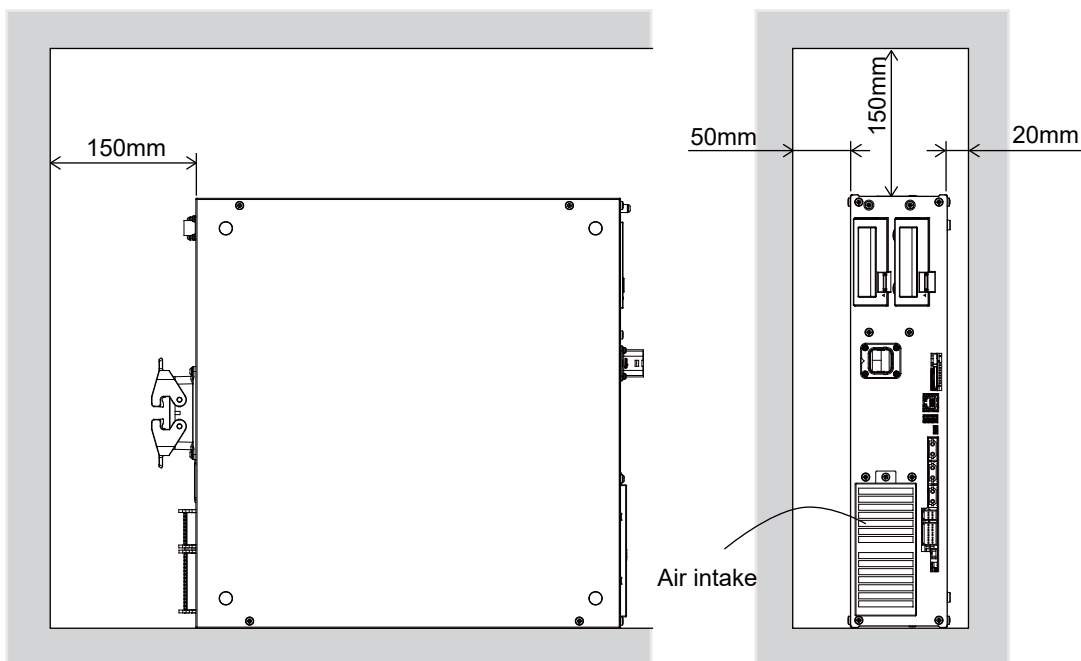

Fig.: Installation dimensions

⚠ CAUTION

When installing the controller vertically, ensure that the air intake is at the bottom as illustrated in Fig.: Installation dimensions.

⚠ CAUTION

Fixing installation section sure for prevention from the fall, when using the controller placing vertically. The reference figure of the metal plate for fixing is shown in Fig.: Reference figure of the fixing metal plate for vertical installation.

You should install the metal plate for fixation to the controller with M4 x 8 or the shorter screw. The screw projection length inside the controller (side board thickness is 1.2 mm) surely makes 6.8 mm or less.

⚠ CAUTION

When storing the controller in a cabinet, etc., take special care to the heat radiating properties and ventilation properties so that the ambient temperature remains within the specification values. And, don't install the controller in the position where direct rays or the heat of lighting hits. The skin temperature of the controller may rise, and the error may occur..

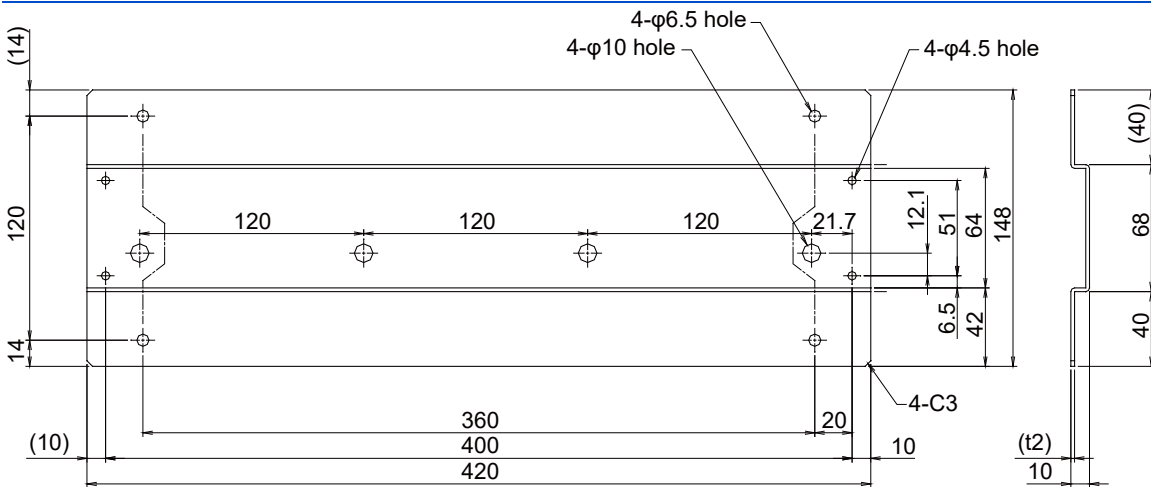

Fig.: Reference figure of the fixing metal plate for vertical installation

Robot CPU unit

Because to improve ventilation and to make unit replacement easy, please secure the following distance between the upper and lower sides of the unit and the structure, etc.

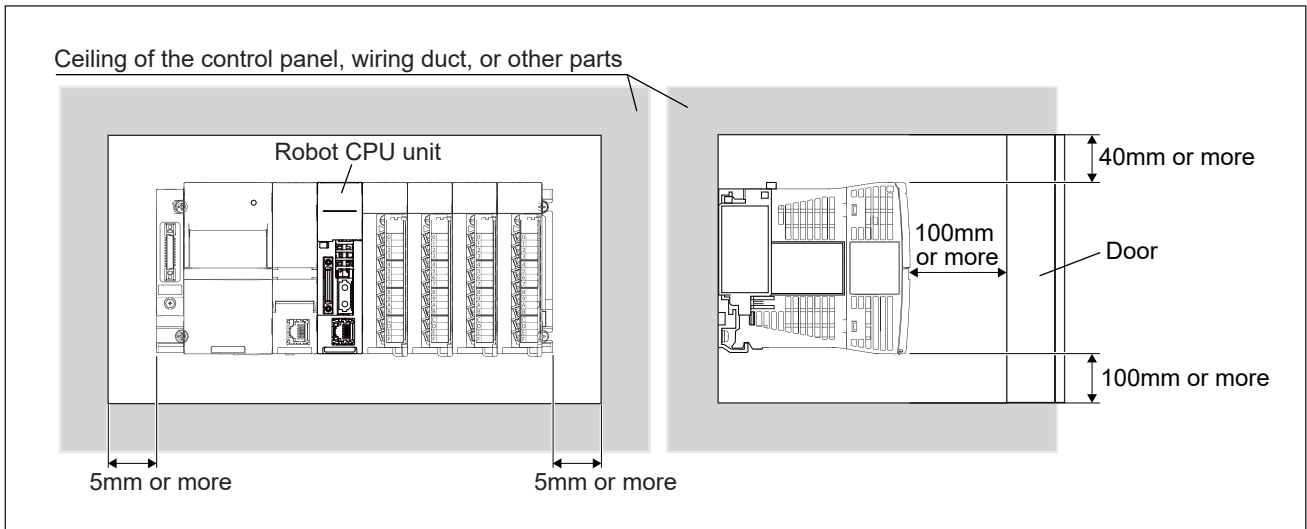

Fig.: Installation of robot CPU Unit

3.4 External input/output

Types

(1) Dedicated input/output

These inputs and outputs carry out the robot remote operation and status display.



(2) General-purpose input/output

These are inputs and outputs that the customer can program for peripheral device control.

(3) Hand input/output

These are inputs and outputs related to the hand that the customer can program.

(4) Emergency stop/Door switch input

Information on wiring the emergency stop and wiring used to ensure safety can be found on  Page 214 Emergency stop input and output etc. and  Page 278 Examples of safety measures.

<For Reference>

Linking our GOT2000 Series display equipment to the robot controller over the Ethernet permits you to control robot controller's input/output from a GOT (graphic operation terminal).

3.5 Dedicated input/output



Show the main function of dedicated input/output in the  Table: Dedicated input/output list. Refer to attached instruction manual  CR800 Series Controller INSTRUCTION MANUAL Detailed explanations of functions and operations (BFP-A3478) in the product for the other functions. Each parameter indicated with the parameter name is used by designated the signal No., assigned in the order of input signal No. and output signal No.

Table: Dedicated input/output list

Parameter name	Input *1			Output	
	Name	Function	Level	Name	Function
TEACHMD	None			Teaching mode output signal	Outputs that the teaching mode is entered.
ATTOPMD	None			Automatic mode output signal	Outputs that the automatic mode is entered.
ATEXTMD	None			Remote mode output signal	Outputs that the remote mode is entered.
RCREADY	None			Controller power ON complete signal	Outputs that external input signals can be received.
AUTOENA	Automatic operation enabled input signal	Allows automatic operation.	L	Automatic operation enabled output signal	Outputs the automatic operation enabled state.
START	Start input signal	Starts all slots.	E	Operating output signal	Outputs that the slot is operating.
STOP	Stop input signal	Stops all slots. The input signal No. is fixed to 0. Note) Use the emergency stop input for stop inputs related to safety.	L	Wait output signal	Outputs that the slot is temporarily stopped.
STOP2	Stop input signal	The program during operation is stopped. Unlike the STOP parameter, change of the signal number is possible. Notes) Specification is the same as the STOP parameter.	L	Wait output signal	Outputs that the slot is temporarily stopped. Notes) Specification is the same as the STOP parameter.
SLOTINIT	Program reset input signal	Resets the wait state.	E	Program selection enabled output signal	Outputs that the slot is in the program selection enabled state.
ERRRESET	Error reset input signal	Resets the error state.	E	Error occurring output signal	Outputs that an error has occurred.
CYCLE	Cycle stop input signal	Carries out cycle stop.	E	In cycle stop operation output signal	Outputs that the cycle stop is operating.
SRVOFF	Servo ON enabled input signal	Turns the servo OFF for all mechanisms.	L	Servo ON enabled output signal	Outputs servo-on disable status. (Echo back)
SRVON	Servo ON input signal	Powers on the robot servos. For multiple mechanisms, it powers on the servos of all the mechanisms.	E	In servo ON output signal	Outputs the servo ON state. For multiple mechanisms, the output is performed when at least one of the mechanisms is in the servo ON state.
IOENA	Operation rights input signal	Requests the operation rights for the external signal control.	L	Operation rights output signal	Outputs the operation rights valid state for the external signal control.
MELOCK	Machine lock input signal	Sets/resets the machine lock state for all mechanisms.	E	In machine lock output signal	Outputs the machine lock state.
SAFEPOS	Evasion point return input signal	Requests the evasion point return operation.	E	In evasion point return output signal	Outputs that the evasion point return is taking place.
OUTRESET	General-purpose output signal reset	Resets the general-purpose output signal.	E	None	
EMGERR	None			Emergency stop output signal	Outputs that an emergency stop has occurred.
S1START : S32START	Start input	Starts each slot.	E	In operation output	Outputs the operating state for each slot.
S1STOP : S32STOP	Stop input	Stops each slot.	L	In wait output	Outputs that each slot is temporarily stopped.

Parameter name	Input *1			Output	
	Name	Function	Level	Name	Function
PRGSEL	Program selection input signal	Designates the setting value for the program No. with numeric value input signals.	E	None	
OVRDSEL	Override selection input signal	Designates the setting value for the override with the numeric value input signals.	E	None	
IODATA *2	Numeric value input (start No., end No.)	Used to designate the program name, override value., mechanism value.	L	Numeric value output (start No., end No.)	Used to output the program name, override value., mechanism No.
PRGOUT	Program No. output request	Requests output of the program name.	E	Program No. output signal	Outputs that the program name is being output to the numeric value output signal.
LINEOUT	Line No. output request	Requests output of the line No.	E	Line No. output signal	Outputs that the line No. is being output to the numeric value output signal.
OVRDOUT	Override value output request	Requests the override output.	E	Override value output signal	Outputs that the override value is being output to the numeric value output signal.
ERROUT	Error No. output request	Requests the error No. output.	E	Error No. output signal	Outputs that the error No. is being output to the numeric value output signal.
JOGENA	Jog valid input signal	Validates jog operation with the external signals	E	Jog valid output signal	Outputs that the jog operation with external signals is valid.
JOGM	Jog mode input 2-bit	Designates the jog mode.	L	Jog mode output 2-bit	Outputs the current jog mode.
JOG+	Jog feed + side for 8-axes	Requests the + side jog operation.	L	None	
JOG-	Jog feed - side for 8-axes	Requests the - side jog operation.	L	None	
HNDCNTL1 : HNDCNTL3	None			Mechanism 1 hand output signal status : Mechanism 3 hand output signal status	Mechanism 1: Outputs the status of general-purpose outputs 900 to 907. Mechanism 2: Outputs the status of general-purpose outputs 910 to 917. Mechanism 3: Outputs the status of general-purpose outputs 920 to 927.
HNDSTS1 : HNDSTS3	None			Mechanism 1 hand input signal status : Mechanism 3 hand input signal status	Mechanism 1: Outputs the status of hand inputs 900 to 907. Mechanism 2: Outputs the status of hand inputs 910 to 917. Mechanism 3: Outputs the status of hand inputs 920 to 927.
HNDERR1 : HNDERR3	Mechanism 1 hand error input signal : Mechanism 3 hand error input signal	Requests the hand error occurrence.	L	Mechanism 1 hand error output signal : Mechanism 3 hand error output signal	Outputs that a hand error is occurring.
AIRERR1 : AIRERR3	Pneumatic pressure error 1 input signal : Pneumatic pressure error 3 input signal	Request the pneumatic pressure error occurrence.	L	Pneumatic pressure error 1 output signal. : Pneumatic pressure error 3 output signal.	Outputs that a pneumatic pressure error is occurring.
M1PTEXC : M3PTEXC	None		L	Maintenance parts replacement time warning signal	Outputs that the maintenance parts have reached the replacement time.
USERAREA *3	None			User-designated area 8-points	Outputs that the robot is in the user-designated area.

*1 The level indicates the signal level.

L: Level signal → The designated function is validated when the signal is ON, and is invalidated when the signal is OFF.

E: Edge signal → The designated function is validated when the signal changes from the OFF to ON state, and the function maintains the original state even when the signal then turns OFF.

*2 Four elements are set in the order of input signal start No., end No., output signal start No. and end No.

*3 Up to eight points can be set successively in order of start output signal No. and end output signal No.

3.6 Emergency stop input and output etc.

Do wiring of the external emergency stop, the special stop input, the door switch, and the mode selector switch from the "special input/output" terminal connector.

Table: Special input/output terminal

Item	Name	Function
Input	Emergency stop	Applies the emergency stop. Dual line, normal close
Input	Special stop input	Applies the stop. (Refer to Page 219 Special stop input (SKIP))
Input	Door switch	Servo-off. Dual line, normal close (Page 220 Door switch function)
Input	Mode selector switch	Changes the mode (MANUAL/AUTOMATIC) of the controller. Dual line (Page 221 Mode selector switch function)
Output	Robot error output	Contact is opening during error occurrence.
Output	Emergency stop output	The point of contact opens under occurrence of emergency stop of external input signal, emergency stop of T/B.
Output	Mode output	MANUAL mode: contactor is opening, AUTOMATIC mode: contactor is closing.
Output	Additional axis synchronization output	When an additional axis is used, the servo ON/OFF status of the additional axis can be synchronized with the robot arm. (Page 226 Additional axis synchronization output)

*At the time of the power supply OFF, the output point of contact is always open.

[Note]

Wire for each input terminal as shown in [Fig.: External emergency stop connection](#).

The contact capacity of each input/output terminal is DC24V/100mA. Do not connect the equipment except for this range.

Noise or other effects that overload contact capacities will lead to failure. An example of noise prevention is shown in [Fig.: Protection circuit example](#).

In the customer's system, do not ground the + side of 24V power supply prepared by customer for connect to the controller. (related with emergency stop and parallel input/output) If it connects with the controller under the condition that the + side is grounded, it will lead to failure of controller.

An example of connecting devices such as PLCs

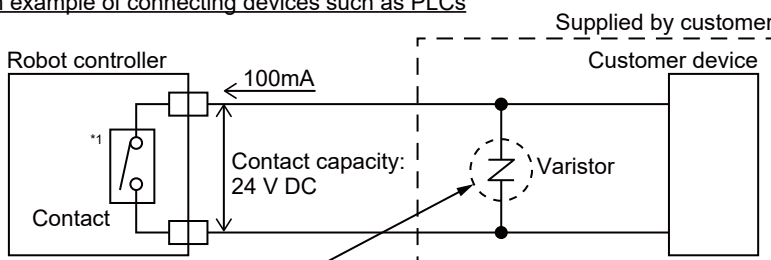

Use noise prevention methods that are specific to the devices being used and the environment they are being used in.

An example of connecting devices such as relays

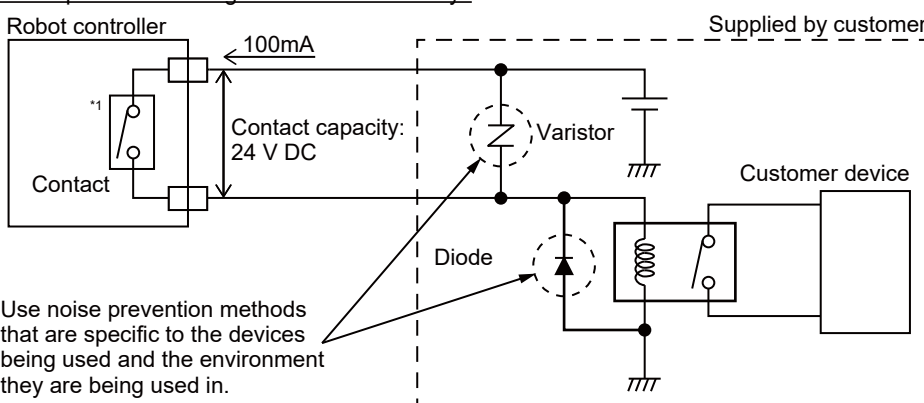

Use noise prevention methods that are specific to the devices being used and the environment they are being used in.

Recommended varistor

Model	Manufacturer	Varistor voltage	Max. permissible circuit voltage
ERZV10D390	Panasonic	39V	31V
72210S0250K101	TDK	39V	31V

Fig.: Protection circuit example

*1 The actual internal robot controller circuit differs from the internal robot controller circuit in the figure.



[Note]

If a stop signal or servo OFF signal is input simultaneously with a door switch open/emergency stop input, the error, H056n "Servo sys. error (A/D)" may occur.

When a door switch open/emergency stop is input, the robot turns off the servo after it stops. It is unnecessary to input a stop signal or servo OFF signal. To input a stop signal or servo OFF signal with a door switch open/emergency stop input, wait for 100ms or more after a door switch open/emergency stop input.

Pin number assignment of each terminal and the circuit diagram are shown in  Fig.: External emergency stop connection.

Connection of the external emergency stop and mode selector switch

The input terminals for the external emergency stop, door switch, and mode selector switch are arranged as shown in  Fig.: External emergency stop connection. Customers should be sure to prepare the external emergency stop, door switch, and mode selector switch, etc. and use the robot while these are connected. Connection procedures are shown below. In addition, refer to  Page 278 Examples of safety measures for the information on the emergency stop connection and cautions.

[Caution]

The emergency stop circuit is duplicated inside the controller. The emergency stop switch uses a double contact-type switch, so please be sure to fix both of the contacts to the connector pins as shown below in order to ensure the wiring is duplicated. An error will continue to occur in the event that only one of the pins is connected.

1) Please prepare the emergency stop switch, door switch, and mode selector switch.

2) Connect the contacts of each switch to the contacts as shown below:

a) External emergency stop switch

CNUSR11 connector "between 7 and 23" and "between 14 and 30".

b) Door switch

CNUSR11 connector "between 6 and 22" and "between 13 and 29".

c) Mode selector switch

CNUSR11 connector "between 5 and 21" and "between 12 and 28".

[Caution]

Be sure to use a shield cable for the emergency stop wiring cable and dedicated stop input wiring cable. And when operating in an environment that is easily affected by noise, be sure to install the ferrite core (recommended model name: E04SR301334, manufacturer: Seiwa Electric Mfg. Co., Ltd.). Be sure to place the ferrite core in 300mm or less from the connecting terminal section.

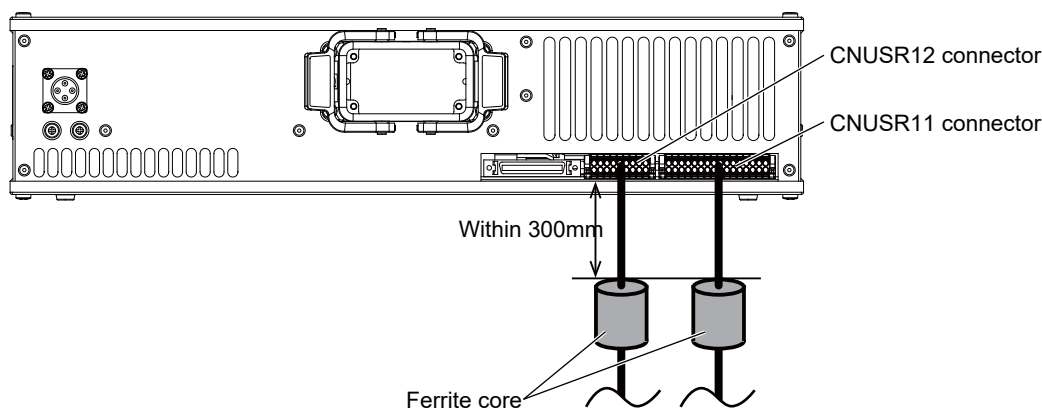

Fig.: Installation position of ferrite cores

For information on the installation method, follow the instructions of the ferrite core being used.

⚠ CAUTION

Make sure there are no mistakes in the wiring. Connecting differently to the way specified in the manual can result in errors, such as the emergency stop not being released. In order to prevent errors occurring, please be sure to check that all functions (such as the teaching box emergency stop, customer emergency stop, and door switch) are working properly after the wiring setup is completed.

⚠ CAUTION

You should always connect doubly connection of the emergency stop, the door switch, and the mode selector switch. In connection of only one side, if the relay of customer use should break down, it may not function correctly.

The robot output contacts (error output, emergency stop output, mode output, additional axis synchronization output) are duplicated output contacts that are wired in series. As with emergency stop switches and door switches, ensure that all connections to customer devices are duplicated to achieve redundancy. The robot output contacts (error output, emergency stop output, mode output, additional axis synchronization output) are duplicated output contacts that are wired in series. As with emergency stop switches and door switches, ensure that all connections to customer devices are duplicated to achieve redundancy.

⚠ CAUTION

Please make sure to wire the multiple emergency stop switches so that they each function independently. Check and make sure that the emergency stop doesn't only function under an AND condition (when multiple emergency stop switches are ON at the same time).

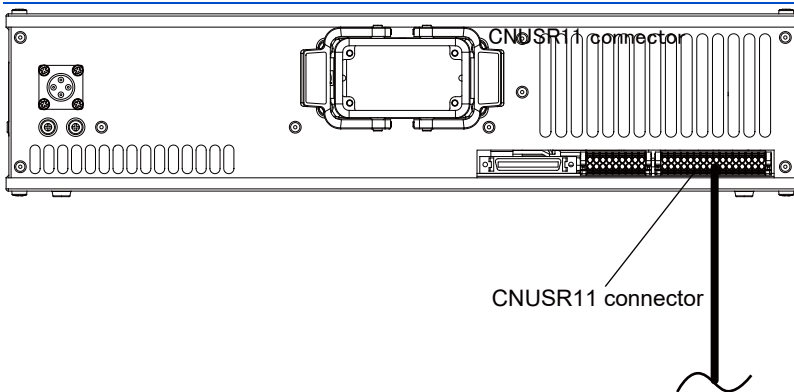

Fig.: Emergency stop cable and mode selector switch connection

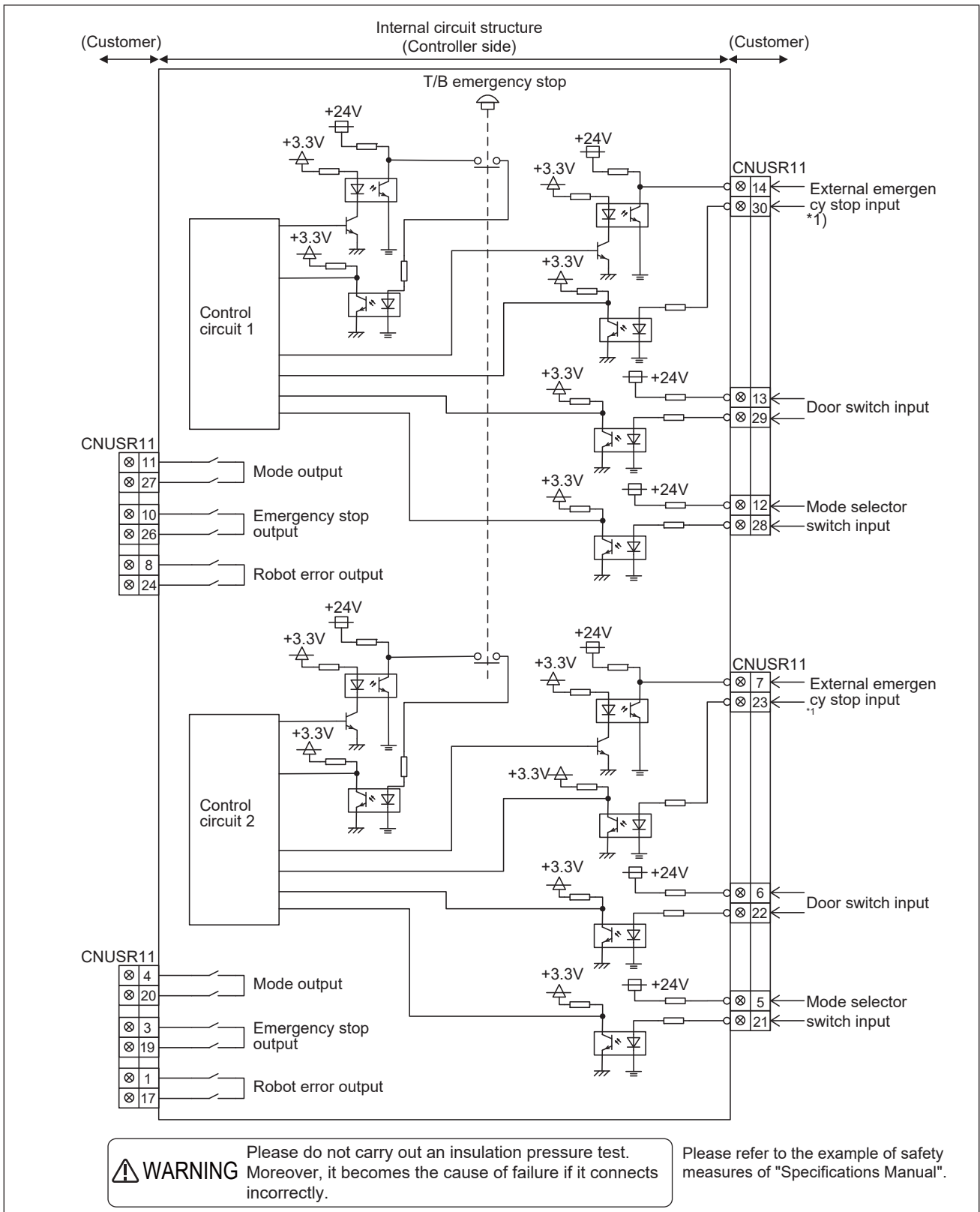

Fig.: External emergency stop connection

*1 The actual internal robot controller circuit differs from the internal robot controller circuit in the figure.

⚠ CAUTION

Place the emergency stop switch in an easily operable position, and be sure to wire it to the emergency stop correctly by referencing [Page 278 Examples of safety measures](#). This is a necessary measure in order to ensure safe operation so that the robot can be stopped immediately by pressing the emergency stop switch in the event that the robot malfunctions.

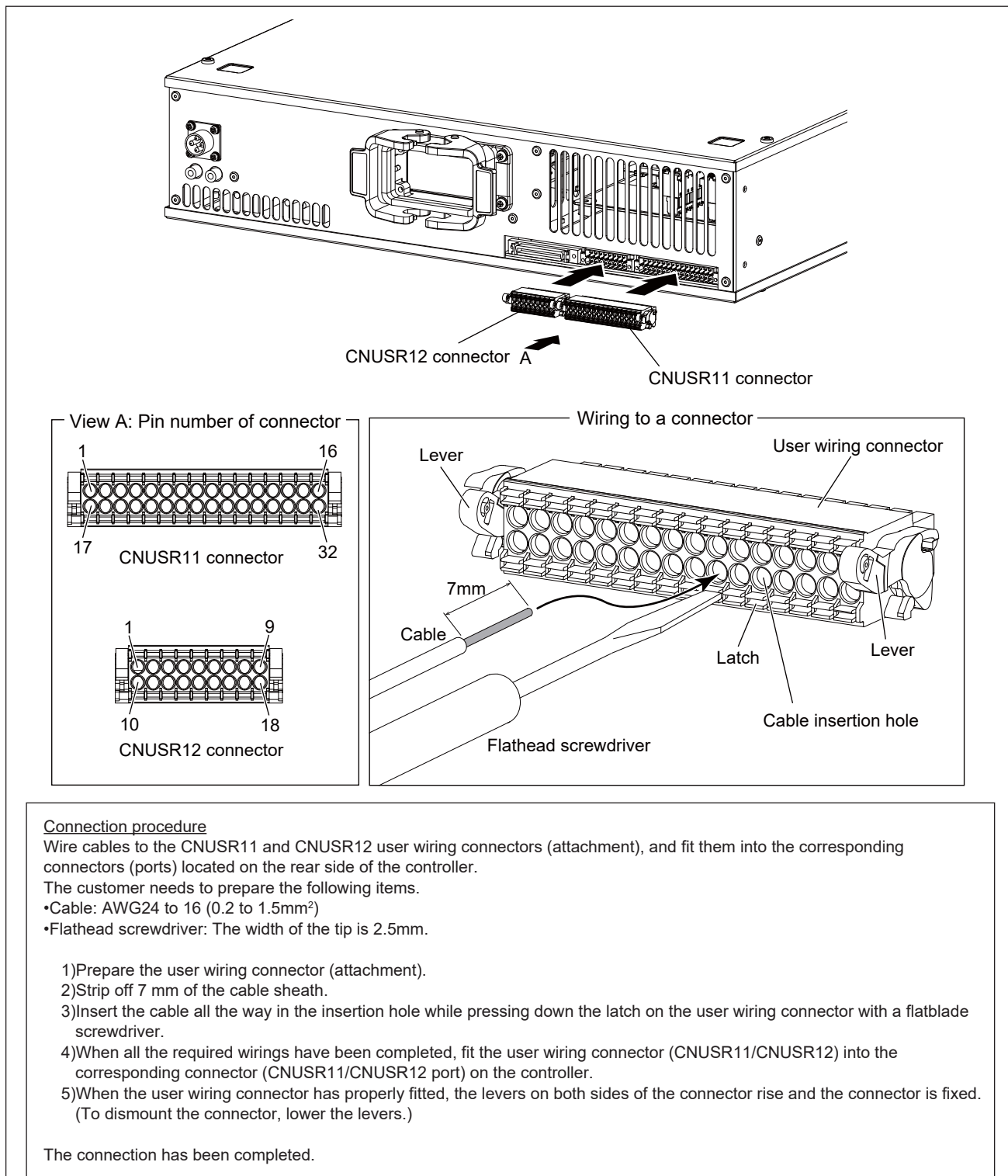

Fig.: Wiring method to the user wiring connector

⚠ CAUTION

Fully check the number of the cable insertion hole (connector pin number) for incorrect connection. Incorrect wiring may damage the robot or cause a malfunction.

⚠ CAUTION

When wiring to the CNUSR11/CNUSR12 connector, pay attention to fraying wires of the core wires. The fraying wires can come into contact with the adjacent terminal, causing a short circuit.

Do not apply solder on core wires. Doing so may cause a contact failure.

Special stop input (SKIP)

The SKIP is the input signal to stop the robot. Please connect the pin 4, 13 of the CNUSR12 connector shown in Fig.: Connection of the special-stop-input.

Table: Special stop input electric specification

Item	Specifications	Internal circuit	
Type	DC input		
No. of input point	1		
Insulation method	Photo-coupler insulation		
Rated input voltage	DC24V		
Rated input current	Approx. 11mA		
Working voltage range	DC 21.6 to 26.4V (Ripple rate within 5%)		
ON voltage/ON current	DC 8V or more / 2mA or more		
OFF voltage/OFF current	DC 4V or less / 1mA or less		
Input resistance	Approx. 2.2kΩ		
Response time	OFF→ON		1ms or less
	ON→OFF		1ms or less
Common method	1 point per common		
External wire connection method	Connector		

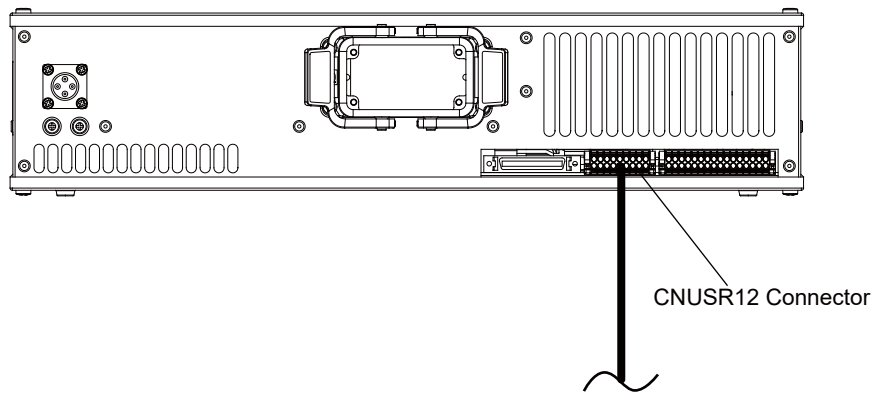



Fig.: Connection of the special-stop-input

*Refer to Fig.: Wiring method to the user wiring connector" for more details about how to wire a connector.

Note) In the customer's system, do not ground the + side of 24V power supply prepared by customer for connect to the controller. (related with emergency stop and parallel input/output) If it connects with the controller under the condition that the + side is grounded, it will lead to failure of controller.

Door switch function

This function acquires the status of the switches attached on the door of the safety fence, and it turns OFF the servo to stop the robot when the door is opened. Perform wiring so that the contact opens when the door is opened.

Follow the wiring example shown in  Fig.: External emergency stop connection and  Page 278 Examples of safety measures). Details of this function according to the robot status are shown below (Fig.: Door switch function).

●During automatic operation

When the door is opened, the servo turns OFF and the robot stops. An error occurs. The process of the restoration: Close the door, reset the alarm, turn on the servo, and restart.

●During teaching

Even when the door is opened, using a selector switch allows to turn the servo ON with the teaching pendant to operate the robot.

①Auto executing

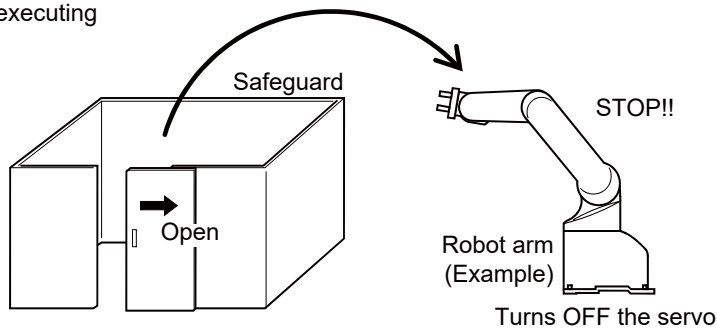

②Teaching

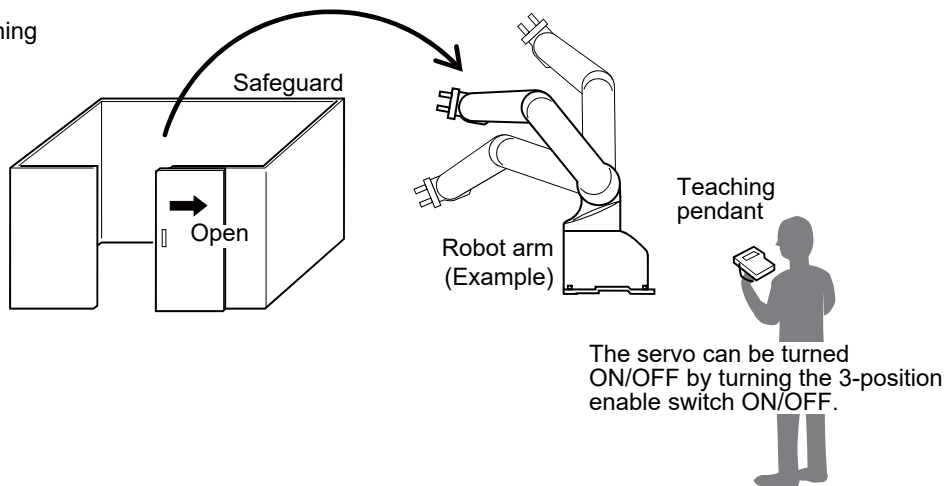

Fig.: Door switch function

Mode selector switch function

The mode selector switch switches the mode of the controller between MANUAL mode and AUTOMATIC mode.

Table: States of input terminal

Mode of controller	Input terminal
MANUAL (Teaching)	Open
AUTOMATIC (Automatic operation)	Close

Automatic Operation/Jog Operation/Brake Release and Necessary Switch Settings

The following is a description of various operations performed on the robot and switch settings that are required.

Table: Various operations and necessary switch settings

No	Operation	Related switch settings ^{*1}				Description
		[T/B ENABLE] switch	3-position enable switch	Mode selector switch input terminal	Door switch input terminal	
1	Jog operation	Enable	ON	Open (MANUAL mode)	—	If the mode selector switch input is set to Open (MANUAL mode), the state of door switch input does not matter.
3	Brake release ^{*2}	Enable	ON	Open (MANUAL mode)	—	If the mode selector switch input is set to Open (MANUAL mode), the state of door switch input does not matter.
4	Automatic operation	Disable	—	Close (AUTOMATIC mode)	Close (Door Close)	Door switch input must always be in a state of Close (Door Close).

*1 "-" in the table indicates that the state of switch concerned does not matter.

Refer to the following for operation of each switch.

•[T/B ENABLE] switch:

☞ Page 228 Teaching pendant (T/B)

•3-position enable switch:

☞ Page 228 Teaching pendant (T/B)

•Mode selector switch input terminal:

☞ Page 278 Examples of safety measures

•Door switch input terminal:

☞ Page 278 Examples of safety measures

*2 T/B is used for the brake release operation. Brake release can be effected only when the 3-position enable switch is placed in intermediate position (lightly gripped position). At this point, the state of door switch input does not matter.

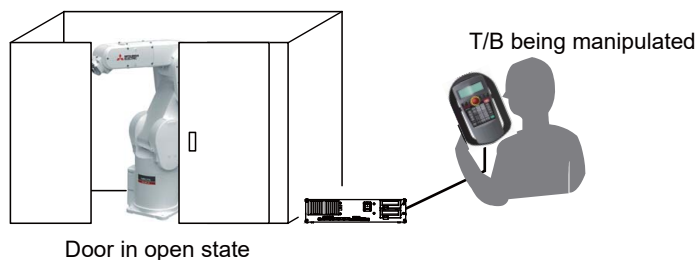

Fig.: Brake release operation

⚠ CAUTION

Upon the release of brake, the robot arm may fall under its own weight depending on the axis which has been released. To ensure safety, take appropriate measures such as supporting the axis to avoid the free fall.

3.7 Additional Axis Function

This controller is equipped with an additional axis interface for controlling an additional axis when a traveling axis or rotary table is added to the robot. A maximum of eight axes of servo motors can be controlled at the same time by connecting a general-purpose servo amplifier (MR-J4-B series) that supports Mitsubishi's SSCNET III.

Refer to CR800 series controller ADDITIONAL AXIS FUNCTION INSTRUCTION MANUAL (BFP-A3504) for details on the additional axis function.

Wiring of the Additional Axis Interface

Table: Dedicated connectors inside the controller shows the connectors for additional axes inside the controller.

Fig.: Example of addition axis connection shows a connection example (configuration example).

Table: Dedicated connectors inside the controller

Name	Connector name	Details
Connector for additional axes	AXIS	The connector for connecting the general-purpose servo amplifier.

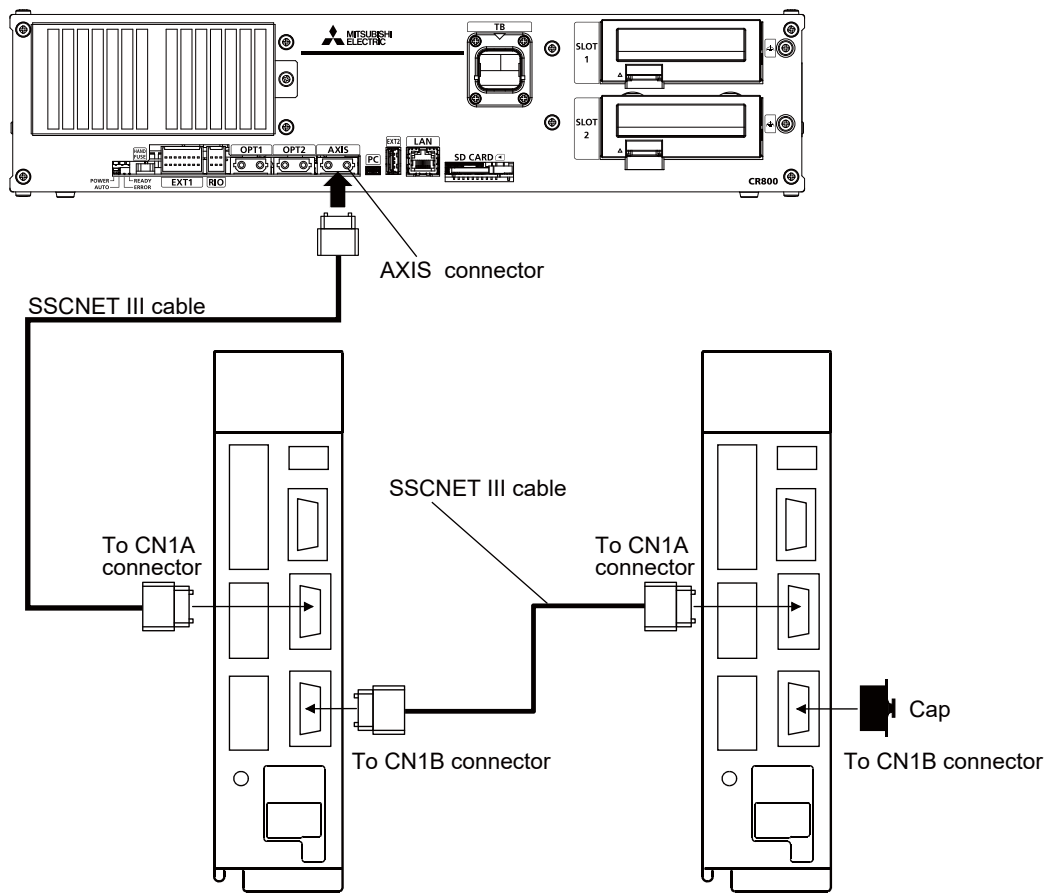

* It cannot communicate, if connection of CN1A and CN1B is mistaken.

Fig.: Example of addition axis connection

Example of the installation of the noise filter

EMC filter (recommended)

Please install the recommendation filter shown below according to the example of connection.

Table: Combination of a servo amplifier and filter (Soshin Electric)

Servo amplifier	Recommended filter (Soshin Electric)				Mass [kg]
	Model	Rated current [A]	Rated voltage [VAC]	Leakage current [mA]	
MR-J4-10B(-RJ) to MR-J4-100B(-RJ)	HF3010A-UN ^{*1}	10	250	5	3.5
MR-J4-200B(-RJ) MR-J4-350B(-RJ)	HF3030A-UN ^{*1}	30			5.5
MR-J4-500B(-RJ) MR-J4-700B(-RJ)	HF3040A-UN ^{*1}	40		6.5	6
MR-J4-11KB(-RJ) MR-J4-15KB(-RJ) MR-J4-22KB(-RJ)	HF3100A-UN ^{*1}	100			12
MR-J4-60B4(-RJ) MR-J4-100B4(-RJ)	TF3005C-TX	5	500	5.5	6
MR-J4-200B4(-RJ) MR-J4-700B4(-RJ)	TF3020C-TX	20			
MR-J4-11KB4(-RJ)	TF3030C-TX	30			
MR-J4-15KB4(-RJ)	TF3040C-TX	40			12.5
MR-J4-22KB4(-RJ)	TF3060C-TX	60			
MR-J4-10B1(-RJ) to MR-J4-40B1(-RJ)	TF3010A-UN ^{*1}	10			250

*1 Following surge protector is separately required to use any of these EMC filters.

RSPD-250-U4 (Manufacture: OKAYA Electric Industries CO., Ltd.)

Table: Combination of a servo amplifier and filter (COSEL)

Servo amplifier	Recommended filter (COSEL)				Mass [kg]
	Model	Rated current [A]	Rated voltage [VAC]	Leakage current [mA]	
MR-J4-11KB(-RJ) to MR-J4-22KB(-RJ)	FTB-100-355-L ^{*1}	100	500	40	5.3
MR-J4-22KB4(-RJ)	FTB-80-355-L ^{*1}	80	500	80	5.3

*1 Following surge protector is separately required to use any of these EMC filters.

RSPD-500-U4 (Manufacture: OKAYA Electric Industries CO., Ltd.)

Installing an EMC noise filter

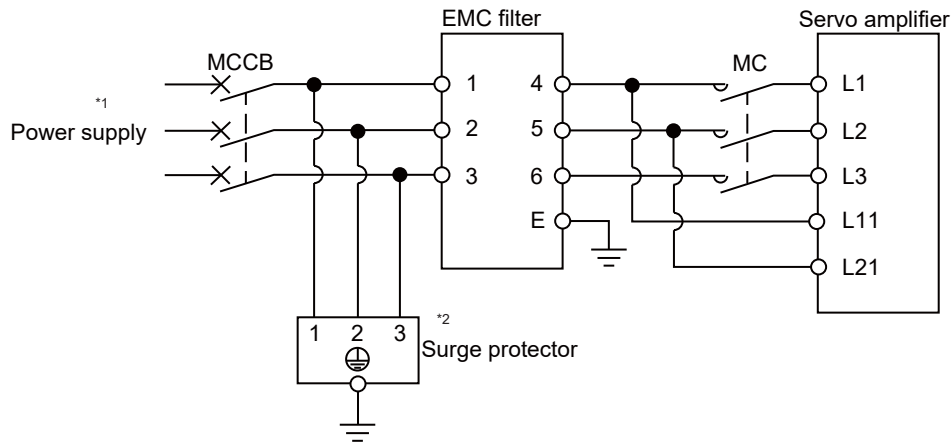

Fig.: Example of EMC noise filter installation

- *1 For 1-phase 200V to 230VAC power supply, connect the power supply to L1, L2 and leave L3 open. There is no L3 for 1-phase 100 to 120 VAC power supply.
- *2 The example is when a surge protector is connected.

Line noise filter

This filter is effective in suppressing noises radiated from the power supply side and output side of the servo amplifier and also in suppressing high-frequency leakage current (zero-phase current) especially within 0.5MHz to 5MHz band.

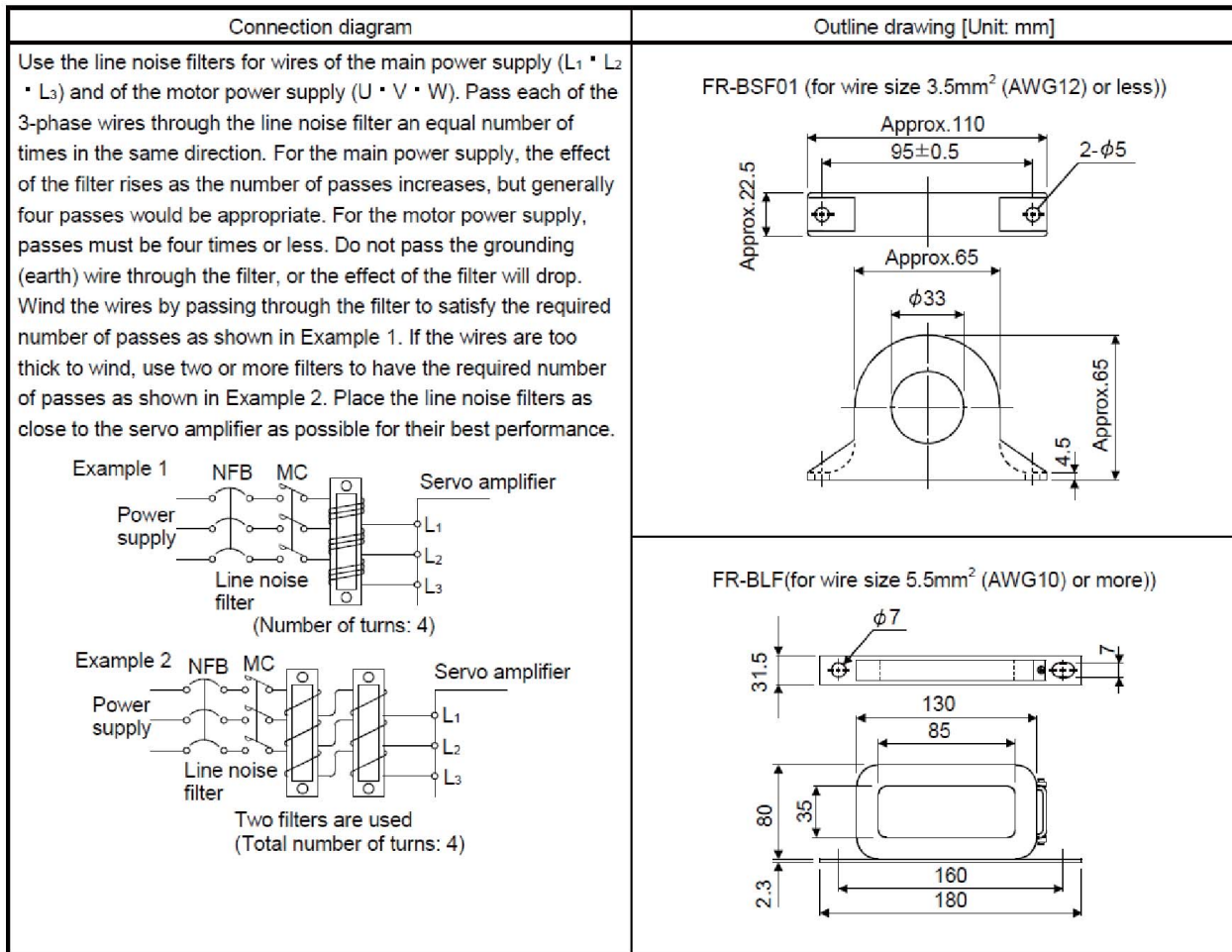

Fig.: Example of noise filter installation

3.8 Additional axis synchronization output

When an additional axis is used, the servo ON/OFF status of the additional axis can be synchronized with the servo ON/OFF status of the robot itself by using the output contact (AXMC) provided on the rear or inside of the controller and configuring a circuit so that the power to the servo amplifier for the additional axis can be turned off when this output is open.

An example circuit is shown in [Example circuit](#). An image of how to connect the connector is shown in [Page 227 Image of how to connect the controller connector](#).

When you are using an additional axis, please perform appropriate circuit connections by referring to these drawings.

Refer to [Page 222 Additional Axis Function](#) and [CR800 series controller ADDITIONAL AXIS FUNCTION INSTRUCTION MANUAL \(BFP-A3504\)](#) for details on the additional axis function.

Note1) you use the addition axis function as a user mechanism who became independent of the robot arm, please do not connect this output signal. Servo-on of the user mechanism may be unable.

Example circuit

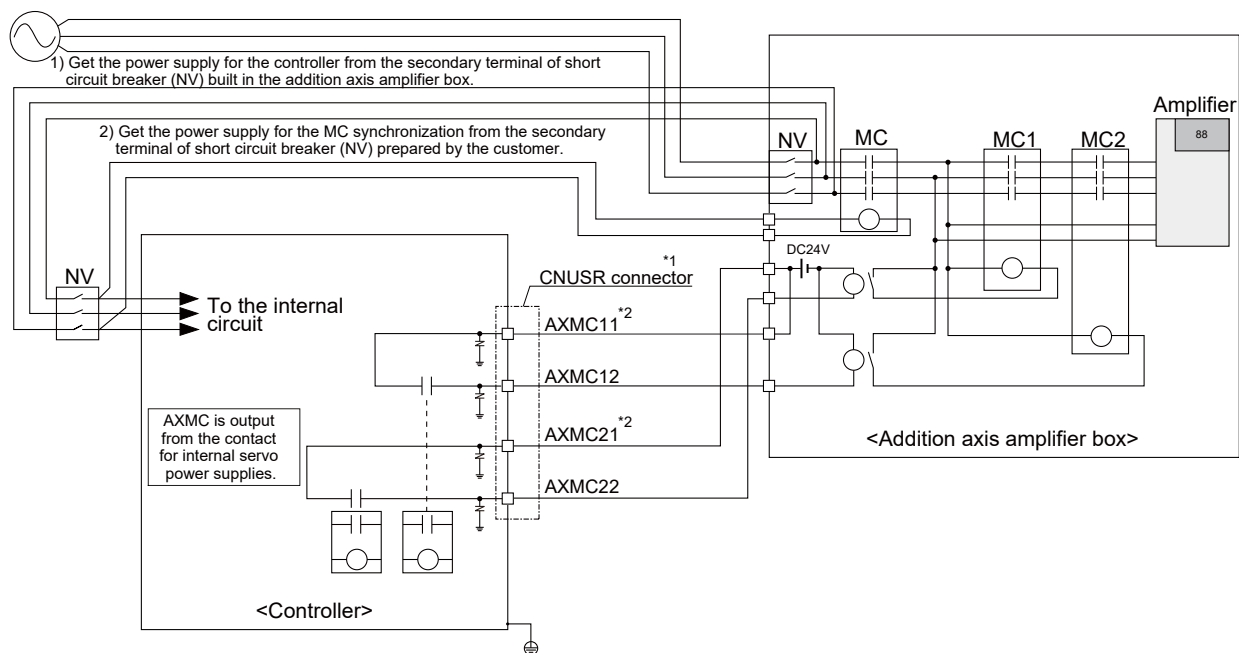

[Note] For the input/output cable (CNUSR connector cable) that connects customer's system and the controller, prevent ground faults from occurring at the + side of the 24V power supply prepared by customer. A ground fault may lead to a failure of the protection device in the controller.

Bending or frictional forces may be applied to the input/output cable repeatedly depending on the system configuration or layout. In this case, use a flexible cable for the input/output cable. Note that a fixed cable may be broken, resulting in a ground fault.

Fig.: Example of circuit for additional axis synchronization output

*1 Connector and pin number.

Signal	Connector	Pin number
AXMC11	CNUSR11	9
AXMC12		25
AXMC21	CNUSR11	2
AXMC22		18

*2 This output is opened, if the robot turns off the servo by occurrence of alarm etc.

<Electric specification>

DC24V/10mA to 100mA

Image of how to connect the controller connector

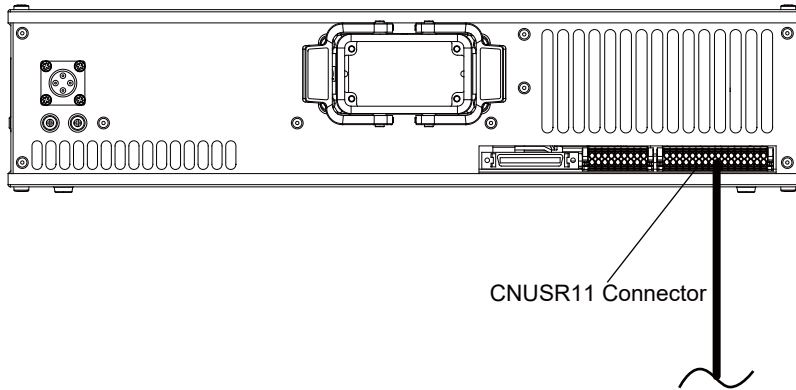



Fig.: AXMC terminal connector

*Refer to  Fig.: Wiring method to the user wiring connector for more details about how to wire a connector.

3.9 Options

There are a variety of options for the robot designed to make the setting up process easier for user needs. User installation is required for the options.

CR800-D/R/Q controller common

Teaching pendant (T/B)

■Order type

- R32TB : Cable length 7m
- R32TB-15 : Cable length 15m

■Outline



This is used to create, edit and control the program, teach the operation position and for jog feed, etc. For safety proposes, a 3-position enable switch is mounted.*1

For multiple robots, you can operate them with just one teaching pendant by repeating the removal of it from another robot and the connection of it to the target robot.

*1 <3-position enable switch>

In ISO/10218 (1992) and JIS-B8433 (1993), this is defined as an "enable device". These standards specify that the robot operation using the teaching pendant is enabled only when the "enable device" is at a specified position.

With the Mitsubishi Electric industrial robot, the above "enable device" is configured of an "[T/B ENABLE] switch" and "3-position enable switch".

The 3-position enable switch has three statuses. The following modes are entered according to the switch state.

a) "Not pressed"

The robot does not operate. *)

b) "Pressed lightly"

The robot can be operated and teaching is possible.

c) "Pressed with force"

The robot does not operate. *)

*The operation is the same regardless of whether the switch is pressed (pulled) in the left or right direction.

*)Releasing or forcefully pressing the 3-position enable switch cuts power to the servos in the same way as when the emergency stop is input. This helps to ensure safety.

Operations such as editing programs and displaying the robot's status are possible while the 3-position enable switch is released or forcefully pressed (excludes operating the robot).

■ Configuration

Table: Configuration device

Part name	Type	Qty.	Mass (kg) *1	Remarks
Teaching pendant	R32TB	Either one pc.	1.7	Cable length is 7m.
	R32TB-15		2.8	Cable length is 15m.

*1 Mass indicates one set.

■ Specifications

Table: Specifications

Items	Specifications	Remarks
Outline dimensions	195(W) x 292(H) x 106(D) (refer to outline drawing)	
Body color	Dark gray	
Mass	Approx. 0.9kg (body only, excluding cables)	
Connection method	Connects with controller via connector.	
Interface	RS-422	
Display method	LCD method: 24 characters x 8 lines, LCD illumination: with backlight	At 8x8 font
Operation section	36 keys	

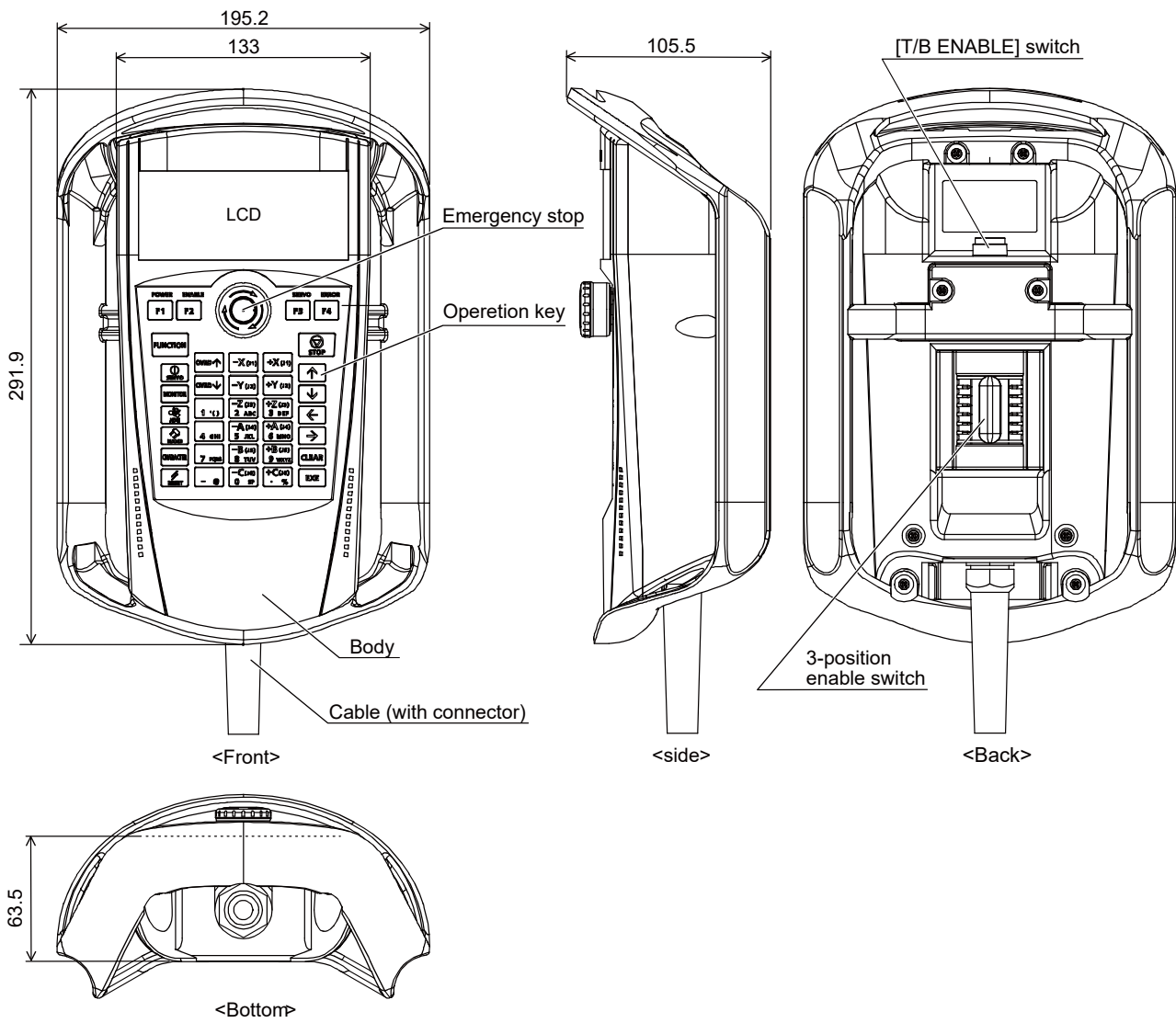

Fig.: Outside dimensions of teaching pendant

■ Installation method

The teaching pendant is connected to the TB connector on the front of the controller.

■Key layout and main functions

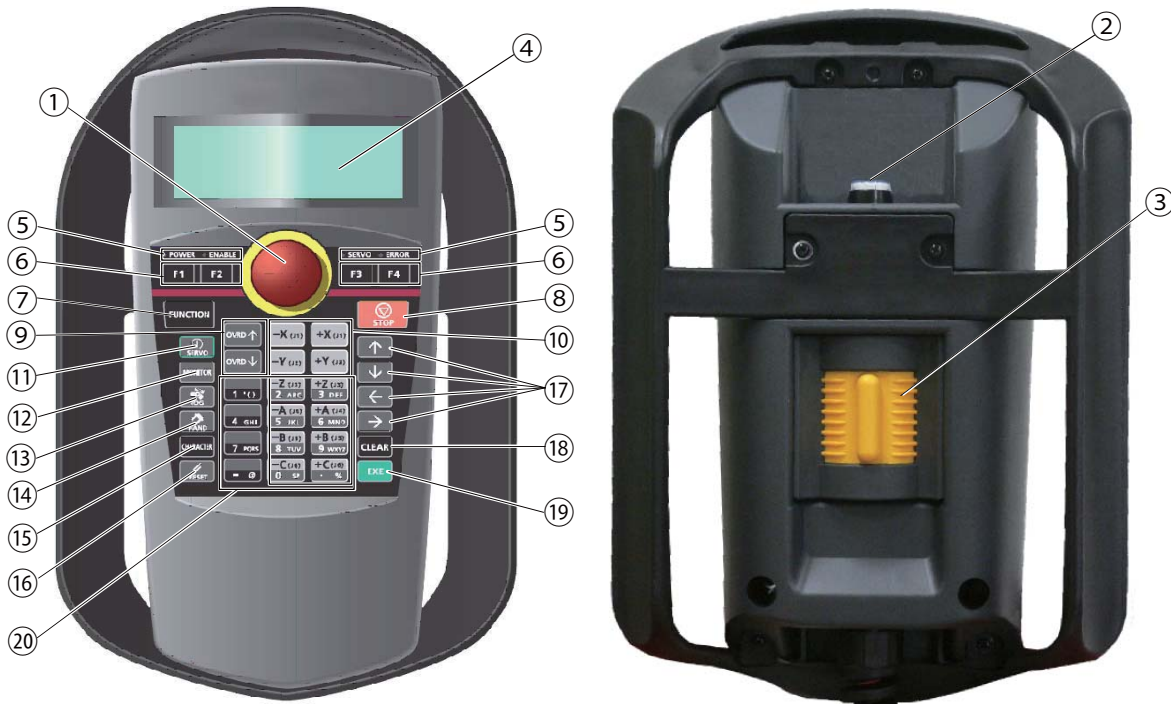

Fig.: Teaching pendant key layout and main functions

No.	Name	Description
1	[Emergency stop] switch	The robot servo turns OFF and the operation stops immediately.
2	[T/B ENABLE] switch	This switch changes the T/B key operation between enable and disable
3	3-position enable switch	When the [T/B ENABLE] switch " 2 " is enabled, and this key is released or pressed with force, the servo will turn OFF, and the operating robot will stop immediately.
4	LCD display panel	The robot status and various menus are displayed.
5	Status display lamp	Display the state of the robot or T/B.
6	[F1], [F2], [F3], [F4]	Execute the function corresponding to each function currently displayed on LCD.
7	[FUNCTION] key	Switch the function display to check another functions assigned to the function keys ([F1], [F2], [F3], and [F4]) when five or more functions are available for next operation, where only four function keys are available.
8	[STOP] key	This stops the program and decelerates the robot to a stop.
9	[OVRD ↑][OVRD ↓] key	Change moving speed. Speed goes up by [OVRD ↑] key. Speed goes down by [OVRD ↓] key
10	[JOG] operation key	Move the robot according to jog mode. And, input the numerical value.
11	[SERVO] key	Press this key with holding 3-position enable switch lightly, then servo power will turn on.
12	[MONITOR] key	It becomes monitor mode and display the monitor menu.
13	[JOG] key	It becomes jog mode and display the jog operation.
14	[HAND] key	It becomes hand mode and display the hand operation.
15	[CHARACTER] key	Switch the function of the number/character keys between number input and character (letter or some special character) input when both inputs are available on the T/B.
16	[RESET] key	This resets the error. The program reset will execute, if this key and the [EXE] key are pressed.
17	[↑][↓][←][→] key	Moves the cursor each direction.
18	[CLEAR] key	Erase a text on the cursor position when number/character input is available.
19	[EXE] key	Input operation is fixed. And, while pressing this key, the robot moves when direct mode.
20	Number/character key	Input the number or character when the number/character input is available.

High-performance teaching pendant (T/B)

Order type

- R56TB : Cable length 7m
- R56TB-15 : Cable length 15m

Outline



This is used to create, edit and control the program, to teach the operation position, or to perform jog feed, etc. This High-performance teaching pendant has a touchscreen graphical user interface (GUI) which allows easy operation. In addition, the 3-position enable switch^{*1} is provided for the safety use.

For multiple robots, you can operate them with just one teaching pendant by repeating the removal of it from another robot and the connection of it to the target robot.

*1 <3-position enable switch>

In ISO/10218 (1992) and JIS-B8433 (1993), this is defined as an "enable device". These standards specify that the robot operation using the teaching pendant is enabled only when the "enable device" is at a specified position.

With the Mitsubishi Electric

industrial robot, the above "enable device" is configured of an "[T/B ENABLE] switch" and "3-position enable switch".

The 3-position enable switch has three statuses. The following modes are entered according to the switch state.

- a) "Not pressed" The robot does not operate. *)
- b) "Pressed lightly" The robot can be operated and teaching is possible.
- c) "Pressed with force" The robot does not operate. *)

*) Releasing or forcefully pressing the 3-position enable switch cuts power to the servos in the same way as when the emergency stop is input. This helps to ensure safety.

Operations such as editing programs and displaying the robot's status are possible while the 3-position enable switch is released or forcefully pressed (excludes operating the robot).

Configuration

Table: Configuration device

Part name	Type	Qty.	Mass (kg) ^{*1}	Remarks
High-performance teaching pendant	R56TB	Either one pc.	2.1	Cable length is 7m.
	R56TB-15		3.2	Cable length is 15m.

*1 Mass indicates one set.

■ Specifications

Table: Specifications

Items	Specifications	Remarks
Outline dimensions	252(W) x 240(H) x 114(D) (refer to outline drawing)	
Body color	Dark gray	
Mass	Approx. 1.25kg (body only, excluding cables)	
Connection method	Connects with controller via connector.	
Interface	RS-422, Ethernet (10BASE-T)	For connection with robot controller
	USB host	*1
Display	6.5" TFT (640 x 480) color touchscreen, with backlight	

- *1 The operation of the following USB memory sticks has been confirmed.
- a) Kingston Data Traveler Manufacture: Kingston, Type: USB 2.0 memory stick, Memory sizes: 128 MB - 1GB
 - b) Transcend Jet Flash Manufacture: Transcend, Type: USB 2.0 memory stick, Memory sizes: 128 MB - 1GB
- Notice) The operation of those other than the above is not guaranteed.

■ Installation method

The teaching pendant is connected to the TB connector on the front of the controller.

■Outside dimensions and main functions

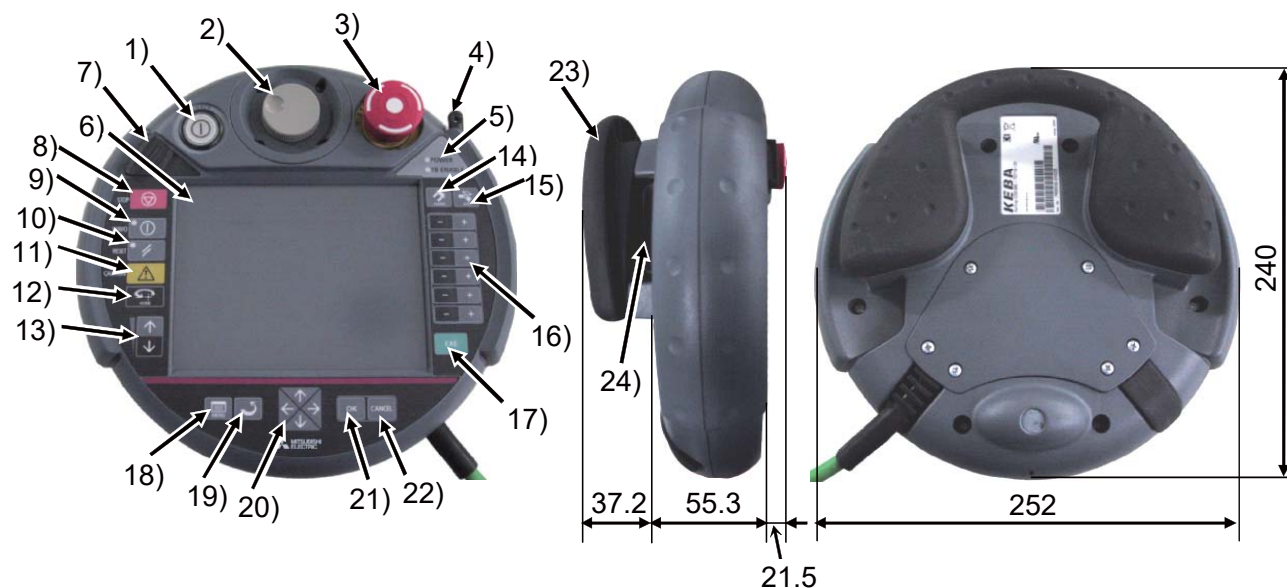

Fig.: Teaching pendant outside dimensions and main functions

No.	Name	Description
1)	TEACH button ([T/B ENABLE] switch)	This changeover switch is used to enable or disable the T/B key operations. The lamp (white) lights up during enabling state.
2)	Wheel	Move the cursor to select the menu and so on.
3)	Emergency stop button	This stops the robot in an emergency state. The servo turns OFF. Turn to the right to cancel.
4)	Touch stylus (Integrated in housing)	The pen which operates the touch panel.
5)	Power supply LED, T/B enable LED	POWER LED lights up during supplying the power supply. TB ENABLE LED lights up during enabling state.
6)	Touch panel	Tap to operate with the stylus pen and the screen is displayed.
7)	USB connector	Plug-in the USB memory stick.
8)	STOP button	This stops the robot immediately. The servo does not turn OFF.
9)	SERVO button	This turns ON the servo power simultaneously with the 3-position enable switch. The LED (green) lights during servo ON.
10)	RESET button	This key resets an error state that has occurred.
11)	CAUTION button	If this button is pushed in jog operation, the limit switch can be canceled. Moreover, push this button, when releasing the brake.
12)	HOME button	Not use.
13)	OVRD button	This scrolls override up or down.
14)	HAND button	Display the screen of hand operation.
15)	JOG button	Display the screen of jog operation
16)	+/- button	This button operates corresponding to the selected operation.
17)	EXE button	Move the robot, such as hand alignment.
18)	MENU button	Display the menu screen.
19)	RETURN button	Close each operation screen.
20)	Arrow button	Move the cursor
21)	OK button	Fix each screen operation.
22)	CANCEL button	Cancel each screen operation.
23)	Multi grip handle.	Holds the T/B.
24)	3-position enable switch	If this switch is released or pressed with force while the T/B is enabled, the servo power supply turns OFF. To move the robot in jog operation or the like, press the switch lightly and hold it. The 3-position enable switch is mounted on each of the multi grip handle.

Function extension card

■Order type

- 2F-DQ510 MELFA Smart Plus card pack (A-type)
- 2F-DQ520 MELFA Smart Plus card pack (AB-type)
- 2F-DQ511 MELFA Smart Plus card (A-type)
- 2F-DQ521 MELFA Smart Plus card (B-type)

■Outline



This card is used to enable the MELFA Smart Plus option.

Insert this card in the option slot on the front of the controller, and enable the MELFA Smart Plus software extension function.

■Configuration

Table: Configuration device

Part name		Type	Qty.	Mass (Kg)	Remarks
MELFA Smart Plus card pack	A-type	2F-DQ510	1	0.5	
	AB-type	2F-DQ520	1	0.5	Software version of controller: Ver. A3 or later
MELFA Smart Plus card	A-type	2F-DQ511	1	0.5	
	B-type	2F-DQ521	1	0.5	Software version of controller: Ver. A3 or later

Controller protection box

■Order type

CR800-MB

■Outline

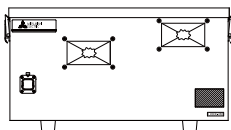

Storing the controller in this box protects the controller from dust and water.

Use this option, when the controller is installed where environment is oil mist such as machine shop etc.

■Configuration

Table: Configuration equipment and types

Part name	Type	Qty.	Mass (Kg) *1	Remarks
Controller protection box	CR800-MB	1	21	
Label for serial number		1		
Transparent seal		1		
Cable tie	T50L	4		
Screw for fixing of the controller mounting plate	M4x8	4		
Instruction Manual	BFP-A3501	1	—	

*1 Mass indicates one set.

■Specifications

Table: Specifications

Item	Unit	Specifications	Remarks
Outside dimension	mm	500(W)×725(D)×250(H)	Protrusions such as rubber legs are excluded.
Mass	kg	21	
Construction		IP54 *1	Self-contained floor type
Grounding	Ω	100 or less (class D grounding)	
Paint color		Dark gray	Equivalent to Munsell: 3.5PB3.2/0.8, PANTONE: 432C

*1 In the environment where oil, such as machining oil, drops on the controller protection box, provide a shield plate to protect the controller protection box from the oil droplets.

(1) The robot must be grounded by the customer.

(2) The customer needs to prepare the power cable for protection box fan and the grounding cable.

(Power supply voltage for fan: 200 VAC, Screw size for power supply connection terminal block: M4)

■ Outside dimension

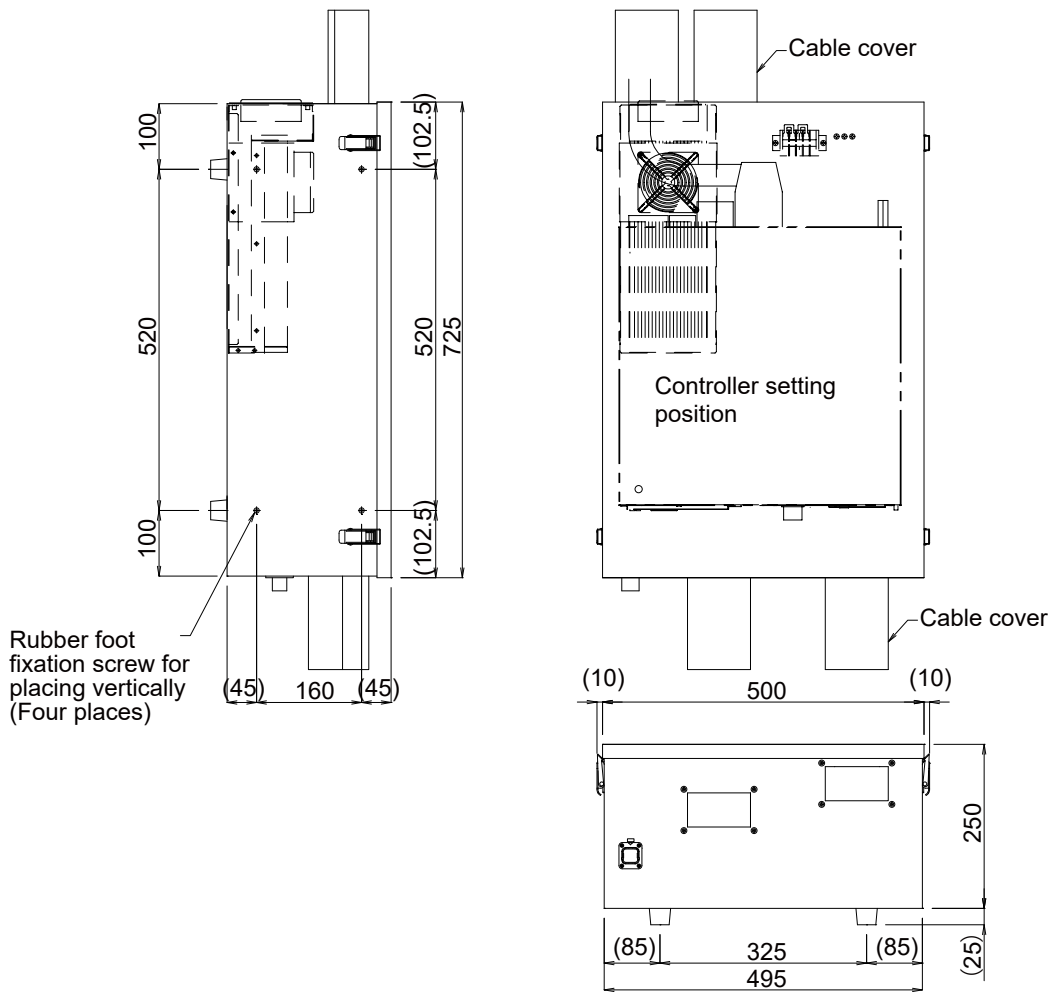

Fig.: Outside dimension

■ Names of each part

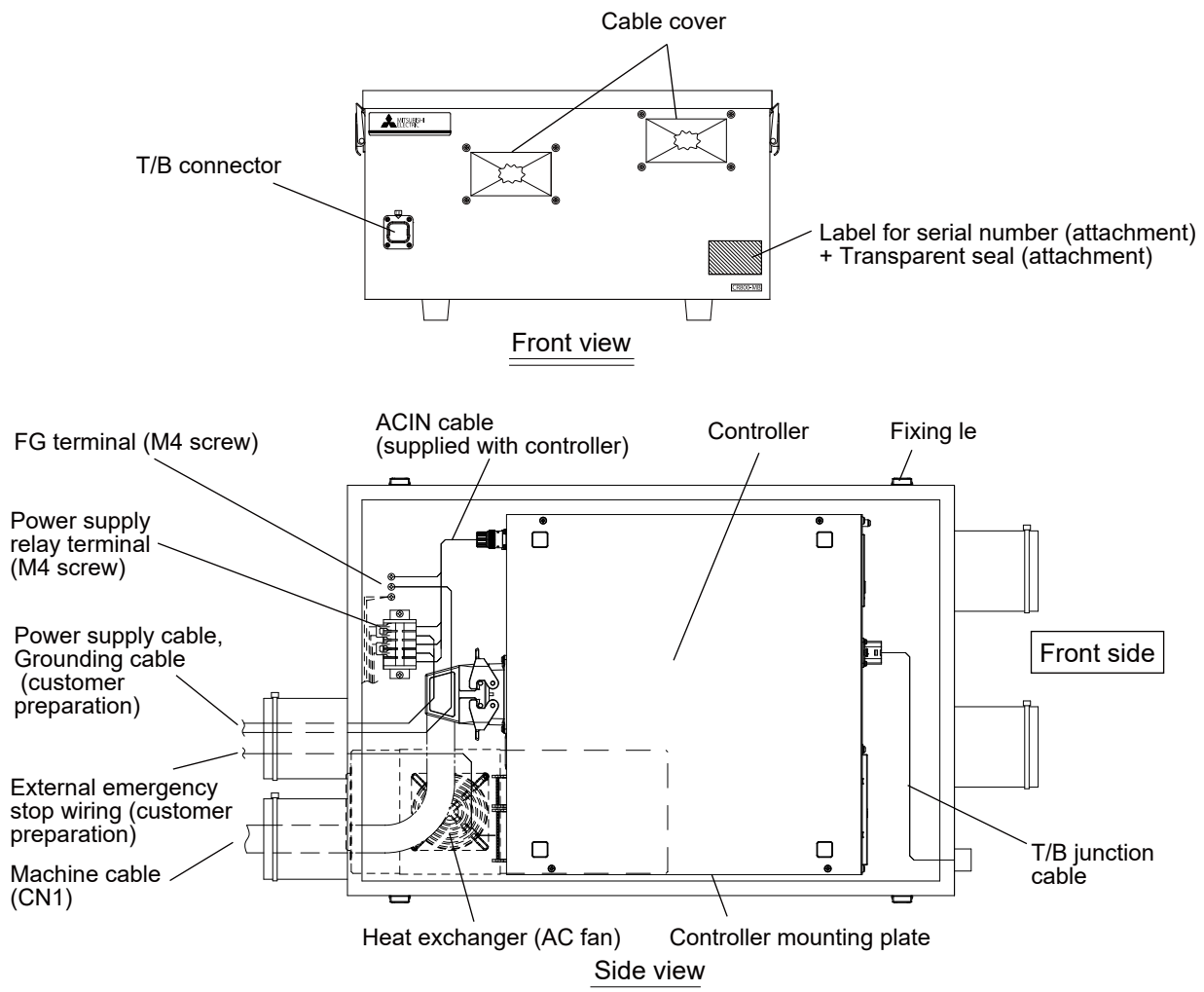

Fig.: Names of each part

■Wiring system diagram

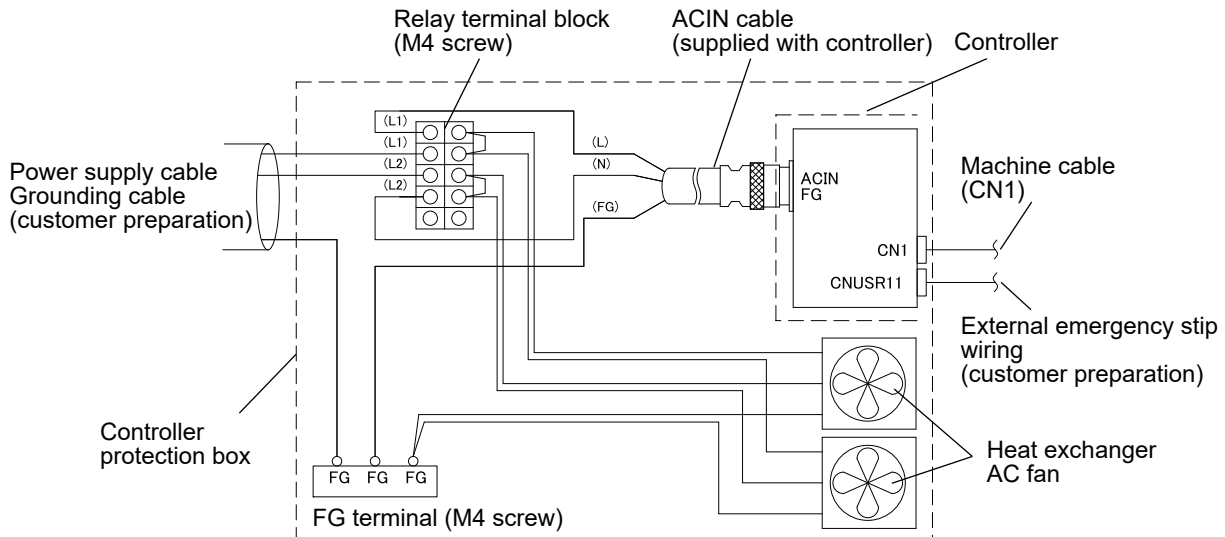

Fig.: Wiring system diagram

[Note]

The figure above is a diagrammatic illustration. The layout inside the controller protection box shown in the figure differs from the actual layout.

■ Installation dimensions

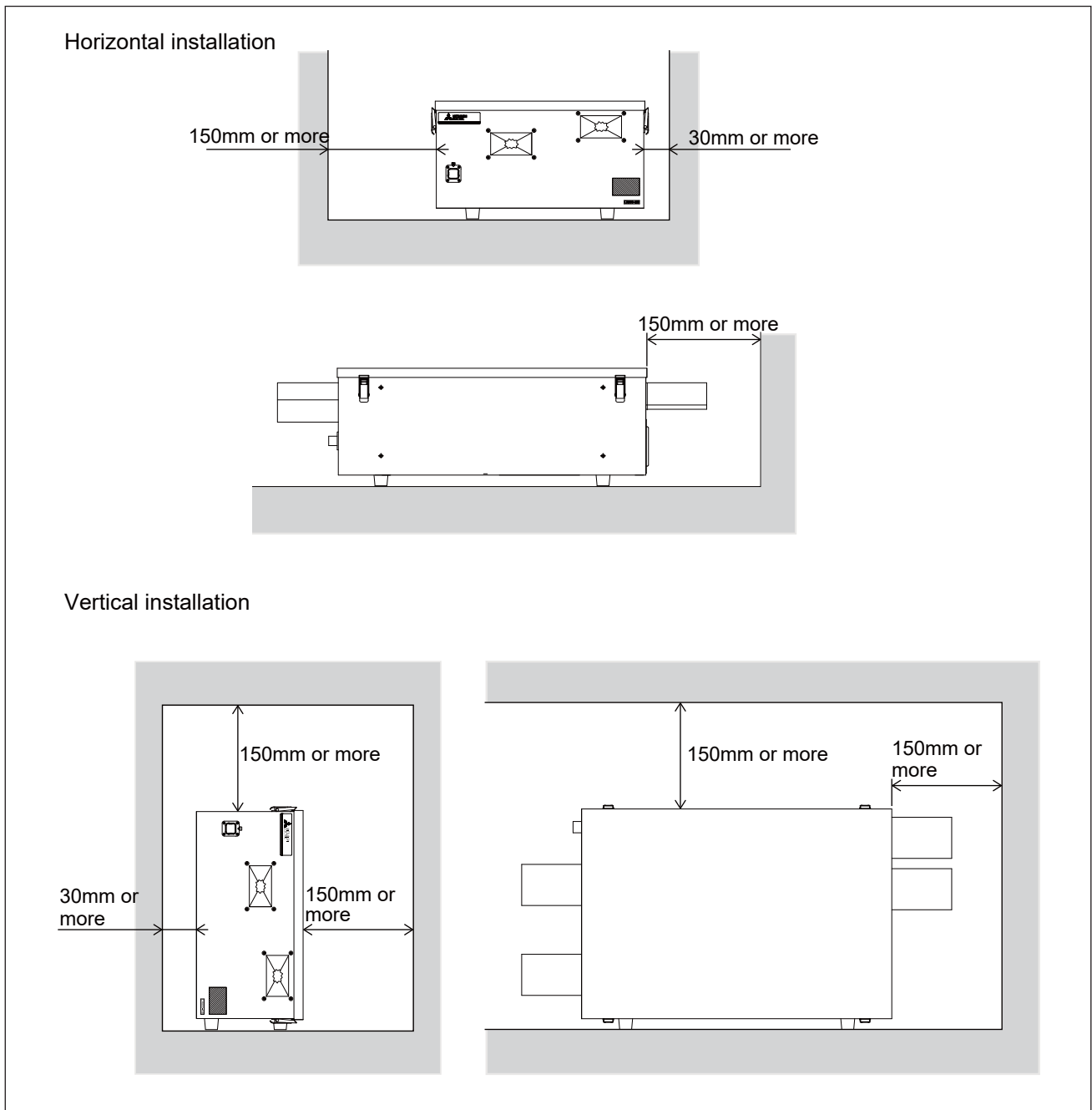

Fig.: Installation dimensions

MELSOFT RT ToolBox3/MELSOFT RT ToolBox3 mini/MELSOFT RT ToolBox3 Pro

■Order type

●MELSOFT RT ToolBox3

•For windows DVD-ROM: 3F-14C-WINE

●MELSOFT RT ToolBox3 mini

•For windows DVD-ROM: 3F-15C-WINE

●MELSOFT RT ToolBox3 Pro

•For windows DVD-ROM: 3F-16D-WINE

■Outline



This is handy software that fully uses the personal computer functions. It can be used in various stages from the robot specifications study (tact study, etc.) to the design support (creation and editing of programs), start up support (execution, control and debugging of program), and maintenance (maintenance forecast).

■Configuration

Table: Product configuration

Part name	Type	Medium	Mass (kg) *1	Remarks
RT ToolBox3	3F-14C-WINE	DVD-ROM	0.2	
RT ToolBox3 mini	3F-15C-WINE	DVD-ROM	0.2	
RT ToolBox3 Pro	3F-16D-WINE	DVD-ROM	0.2	

*1 Mass indicates one set.

■Features

(1) Simple operation with guidance method and menu method

The Windows standard is used for windows operation, so the controller initialization and startup operations can be carried out easily by following the instructions given on the screen. Even a beginner can easily carry out the series of operations from program creation to execution.

(2) Increased work efficiency with ample support functions

The work efficiency is greatly improved with the multi-window method that carries out multiple steps and displays in parallel. The renumbering function, and copy, search, syntax check and step execution are especially sufficient, and are extremely useful when editing or debugging the program.

With the simulation function support of MELSOFT RT ToolBox3, the program can be debugged and the tact checked before starting the machine at the site. This allows the on-site startup work efficiently to be greatly improved.

MELSOFT RT ToolBox3 Pro allows a simulation of robot operation on three-dimensional CAD software SolidWorks®.

(3) The maintenance forecast function increases the efficiency of maintenance work. Analyze the load condition while the robot is actually operating. Based on this analysis, calculate the time for maintenance, such as lubrication and belt replacement. By utilizing this information, the line stop time as well as the maintenance costs can be reduced.

(4) The position recovery support function increases the recovery efficiency in the event of origin position displacement. This function compensates the origin settings and position data by just reproducing several previous teaching points when hand and/or arm displacement occurs, when replacing the motor and the belts, or when reloading the robot. This function can reduce the time required for recovery.

■ Functions

Table: Functions

Function		Functional existence *1			Details
		*3	*4	*5	
Compatible model		○	○	○	Personal computer running Windows 10 or Windows 11. *2
Program editing functions	Editing functions	○	○	○	MELFA BASIC V, VI language compatible Multiple editing screen simultaneously display Command input, comment writing Position data editing File operation (writing to controller, personal computer) Search and replace function (using characters, line Nos., labels) Copy, cut, paste, insert (per character, line), undo (per command statement, position conversion) Line No. automatic generation, renumbering Batch syntax check Command template Position conversion batch editing Position variable template Print, print preview
	Control functions	○	○	○	Program file control (list, copy, movement, delete, content comparison, name change, protect)
	Debugging functions	○	○	○	Direct editing of program in controller Confirmation of robot program operation (step execution, direct execution)
Simulation function		○	○	×	Off-line simulation of robot program operation using CG (computer graphics) Tact time calculation
Monitor functions		○	○	○	Robot operation monitor (robot operation state, stop signal, error monitor, program monitor (execution program, variables), general-purpose input/output signals (forced output possible), dedicated input/output signals, operation confirmation (operation range, current position, hand, etc.) Operation monitor (working time statistics, production information, robot version) Servo monitor (load)
Maintenance function		○	○	○	Parameter setting Batch, divided backup
Simulation function on SolidWorks.		○	×	×	Off-line simulation of robot program operation using CG (computer graphics) Tact time calculation Complex motion path generation, etc.

*1 The functions included with the MELSOFT RT ToolBox3, MELSOFT RT ToolBox3 mini, and the MELSOFT RT ToolBox3 Pro are shown below.

○: Function provided ×: Function not provided

*2 Recommend corresponding to CE Marking, an FCC standard, and a VCCI standard.

*3 MELSOFT RT ToolBox3 Pro (3F-16D-WINE)

*4 MELSOFT RT ToolBox3 (3F-14C-WINE)

*5 MELSOFT RT ToolBox3 mini (3F-15C-WINE)

Instruction Manual (bookbinding)

■Order type

- 5F-GG01-PE01: RH-FRH series

■Outline



This is a printed version of the CD-ROM (instruction manual) supplied with this product.

■Configuration

Table: Product configuration

Name	Type	Mass (Kg) ^{*1}	Specifications
Instruction Manual	5F-GG01-PE01	3.0	The instructions manual set of RH-FRH series.
Safety Manual	BFP-A3541	—	Items relating to safety in handling the robot
Standard Specifications	BFP-A3468	—	Specification of the robot arm and controller
Robot Arm Setup & Maintenance	BFP-A3472	—	Installation method of the robot arm, jog operation, and maintenance and inspection procedures
Controller Setup, Basic Operation and Maintenance	BFP-A3476	—	Installation method of the controller, basic operation, and maintenance and inspection procedures
Detailed Explanation of Functions and Operations	BFP-A3478	—	Functions of the controller and T/B, operation method, and explanation of MELFA-BASIC VI.
Troubleshooting	BFP-A3480	—	Causes of errors occurred and their countermeasures
Additional axis function	BFP-A3504	—	Function of the additional axis, operation method.
Tracking Function	BFP-A3520	—	Function of the tracking, operation method.
GOT Direct Connection Extended Function	BFP-A3546	—	Explains of data configuration of shared memory, monitoring, and operating procedures, between the GOT and controller.
iQ Platform Supporting Extended Function Instruction Manual	BFP-A3528	—	Explains of data configuration of shared memory, monitoring, and operating procedures, between the PLC and robot controller.
Safety communication function	BFP-A3772	—	Using the safety communication function.
Ethernet Function	BFP-A3379	—	Ethernet communication method between personal computer and robot controller.

*1 Mass indicates one set.

CR800-D controller

Parallel I/O interface

Order type

- 2D-TZ368 (Sink type)/2D-TZ378 (Source type)

Outline



This is used to expand the external inputs and outputs.

- The connecting cable with external equipment is not attached. Since we are preparing the external input-and-output cable (2D-CBL05 or 2D-CBL15) as the option, please use.

Notes)Although the combined use with the parallel input-and-output unit (2A-RZ361/2A-RZ371) of another option is also possible, please use the setup of the station number by the different number separately. The station number is automatically determined by the position of the option slot which installed this interface. (station number 0 to 1)

Configuration

Table: Configuration device

Part name	Type	Qty.	Mass (kg) *1	Remarks
Parallel I/O interface	2D-TZ368	Either one pc.	0.4	Input/output 32 points/32 points 2D-TZ368 is sink type. 2D-TZ378 is source type.
	2D-TZ378			

*1 Mass indicates one set.

Specifications

Table: Electrical specifications of input circuits

Item	Specification	Internal circuit	
Type	DC input	<p><Sink type></p>	
Number of input points	32		
Insulation method	Photo coupler insulation		
Rated input voltage	DC12V		DC24V
Rated input current	Approx. 3mA		Approx.9mA
Working voltage range	DC10.2-26.4V (Ripple factor should be less than 5%)		
ON voltage/ON current	DC8V or more/2mA or more		
OFF voltage/ OFF current	DC4V or less/1mA or less		
Input resistance	Approx. 2.7kΩ		
Response time	OFF-ON		10ms or less(DC24V)
	ON-OFF	10ms or less(DC24V)	
Common method	32 points per common		
External cable connection method	Connector		

<Source type>

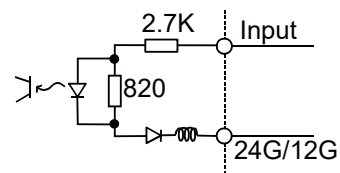

Table: Electrical specifications for the output circuits

Item	Specification	Internal circuit	
Type	Transistor output	<p><Sink type></p> <p><Source type></p>	
No. of output points	32		
Insulation method	Photo-coupler insulation		
Rated load voltage	DC12V/DC24V		
Rated load voltage range	DC10.2-30V (peak voltage DC30V)		
Max. load current	0.1A/point (100%)		
Leakage current at OFF	Within 0.1mA		
Max. voltage drop at ON	DC0.9V(TYP.) *1		
Response time	OFF-ON		10ms or less(Resistance load) (hardware response time)
	ON-OFF		10ms or less(Resistance load) (hardware response time)
Fuse rating	Fuse 1.6A(one per common) Replacement possible (max. 3)		
Common method	16 points per common (common terminal: 2points)		
External wire connection method	Connector		
External power supply	Voltage		DC12/24V(DC10.2-30V)
	Current		60mA(TYP.DC24V per common)(base drive current)

*1 The maximum voltage drop value at signal ON.
Refer to it for the equipment connected to the output circuit.

*A voltage exceeding the rated voltage or incorrect wiring may damage the circuit.

⚠ CAUTION

The protection fuse of the output circuit prevents the failure at the time of the load short circuit and incorrect connection. The load connected of the customer should be careful not to exceed maximum rating current. The internal transistor may be damaged if maximum rating current is exceeded.

■ Installation method

The expansion parallel input/output interface is installed in the controller. Refer to CR800 Controller INSTRUCTION MANUAL Controller setup, basic operation, and maintenance (BFP-A3476) for details on the installing method.

If it installs in the option SLOT of the controller, the station number will be assigned automatically.

SLOT1: station number 0 (0 to 31)

SLOT2: station number 1 (32 to 63)

⚠ CAUTION

If it uses together with parallel input-and-output unit 2A-RZ361/2A-RZ371, please do not overlap with the station number of the parallel input-and-output interface.

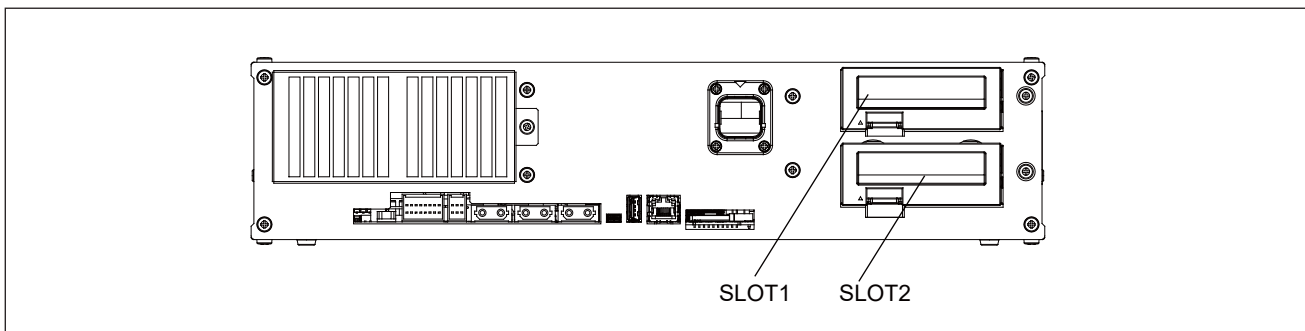

Fig.: Parallel I/O interface installation position

■Pin layout of connector

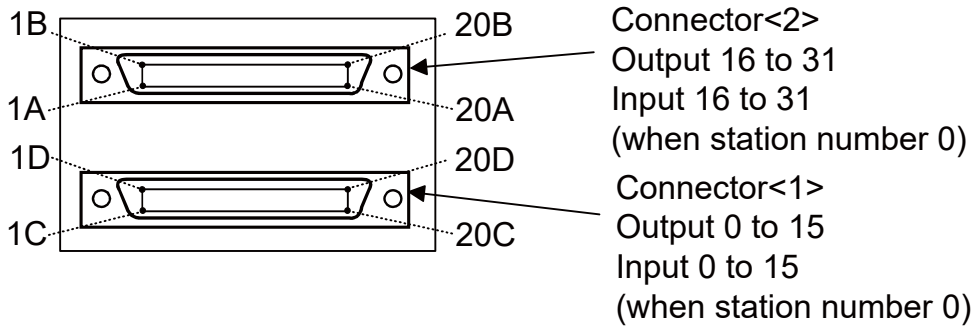

Fig.: Pin layout of connector

■Connector pin No. and signal assignment

The station number is fixed by the slot to install and the allocation range of the general-purpose input-and-output signal is fixed.

Table: The slot number and the station number

Slot number	Station number	Range of the general-purpose input-and-output signal	
		Connector <1>	Connector <2>
SLOT1	0	Input : 0 to 15 Output : 0 to 15	Input : 16 to 31 Output : 16 to 31
SLOT2	1	Input : 32 to 47 Output : 32 to 47	Input : 48 to 63 Output : 48 to 63

The connector pin number of the parallel input-and-output interface installed in SLOT1 and signal number allocation are shown in Table: Connector<1> pin assignment list and external I/O cable (2D-CBL**) color(SLOT1) and Table: Connector<2> pin assignment list and external I/O cable (2D-CBL**) color(SLOT1). If it installs in other slots, please interpret and utilize.

Table: Connector<1> pin assignment list and external I/O cable (2D-CBL**) color(SLOT1)

Pin No.	Line color	Function name		Pin No.	Line color	Function name	
		General-purpose	Dedicated/power supply, common			General-purpose	Dedicated/power supply, common
1C	Orange/Red a		24G/12G: For pins 5D-20D	1D	Orange/Black a		+24V/+12V(COM): For pins 5D-20D
2C	Gray/Red a		COM : For pins 5C-20C* ¹	2D	Gray/Black a		Reserved
3C	White/Red a		Reserved	3D	White/Black a		Reserved
4C	Yellow/Red a		Reserved	4D	Yellow/Black a		Reserved
5C	Pink/Red a	General-purpose input 15		5D	Pink/Black a	General-purpose output 15	
6C	Orange/Red b	General-purpose input 14		6D	Orange/Black b	General-purpose output 14	
7C	Gray/Red b	General-purpose input 13		7D	Gray/Black b	General-purpose output 13	
8C	White/Red b	General-purpose input 12		8D	White/Black b	General-purpose output 12	
9C	Yellow/Red b	General-purpose input 11		9D	Yellow/Black b	General-purpose output 11	
10C	Pink/Red b	General-purpose input 10		10D	Pink/Black b	General-purpose output 10	
11C	Orange/Red c	General-purpose input 9		11D	Orange/Black c	General-purpose output 9	
12C	Gray/Red c	General-purpose input 8		12D	Gray/Black c	General-purpose output 8	
13C	White/Red c	General-purpose input 7		13D	White/Black c	General-purpose output 7	
14C	Yellow/Red c	General-purpose input 6		14D	Yellow/Black c	General-purpose output 6	
15C	Pink/Red c	General-purpose input 5	Operation rights input signal * ²	15D	Pink/Black c	General-purpose output 5	
16C	Orange/Red d	General-purpose input 4	Servo ON input signal * ²	16D	Orange/Black d	General-purpose output 4	
17C	Gray/Red d	General-purpose input 3	Start input * ²	17D	Gray/Black d	General-purpose output 3	Operation rights output signal * ²
18C	White/Red d	General-purpose input 2	Error reset input signal * ²	18D	White/Black d	General-purpose output 2	Error occurring output signal * ²
19C	Yellow/Red d	General-purpose input 1	Servo OFF input signal * ²	19D	Yellow/Black d	General-purpose output 1	In servo ON output signal * ²
20C	Pink/Red d	General-purpose input 0	Stop input * ³	20D	Pink/Black d	General-purpose output 0	Operating output * ²

*1 Sink type: +24V/+12V(COM), Source type: 24G/12G

*2 The dedicated signal is assigned at shipping. It can change with the parameter.

*3 The dedicated input signal (STOP) is assigned at shipping. The signal number is fixing.

Table: Connector<2> pin assignment list and external I/O cable (2D-CBL**) color(SLOT1)

Pin No.	Line color	Function name		Pin No.	Line color	Function name	
		General-purpose	Dedicated/power supply, common			General-purpose	Dedicated/power supply, common
1A	Orange/Red a		24G/12G: For pins 5B-20B	1B	Orange/Black a		+24V/+12V(COM): For pins 5B-20B
2A	Gray/Red a		COM:For pins 5A-20A *1	2B	Gray/Black a		Reserved
3A	White/Red a		Reserved	3B	White/Black a		Reserved
4A	Yellow/Red a		Reserved	4B	Yellow/Black a		Reserved
5A	Pink/Red a	General-purpose input 31		5B	Pink/Black a	General-purpose output 31	
6A	Orange/Red b	General-purpose input 30		6B	Orange/Black b	General-purpose output 30	
7A	Gray/Red b	General-purpose input 29		7B	Gray/Black b	General-purpose output 29	
8A	White/Red b	General-purpose input 28		8B	White/Black b	General-purpose output 28	
9A	Yellow/Red b	General-purpose input 27		9B	Yellow/Black b	General-purpose output 27	
10A	Pink/Red b	General-purpose input 26		10B	Pink/Black b	General-purpose output 26	
11A	Orange/Red c	General-purpose input 25		11B	Orange/Black c	General-purpose output 25	
12A	Gray/Red c	General-purpose input 24		12B	Gray/Black c	General-purpose output 24	
13A	White/Red c	General-purpose input 23		13B	White/Black c	General-purpose output 23	
14A	Yellow/Red c	General-purpose input 22		14B	Yellow/Black c	General-purpose output 22	
15A	Pink/Red c	General-purpose input 21		15B	Pink/Black c	General-purpose output 21	
16A	Orange/Red d	General-purpose input 20		16B	Orange/Black d	General-purpose output 20	
17A	Gray/Red d	General-purpose input 19		17B	Gray/Black d	General-purpose output 19	
18A	White/Red d	General-purpose input 18		18B	White/Black d	General-purpose output 18	
19A	Yellow/Red d	General-purpose input 17		19B	Yellow/Black d	General-purpose output 17	
20A	Pink/Red d	General-purpose input 16		20B	Pink/Black d	General-purpose output 16	

*1 Sink type: +24V/+12V(COM), Source type: 24G/12G

<Reference> The example of connection with our PLC

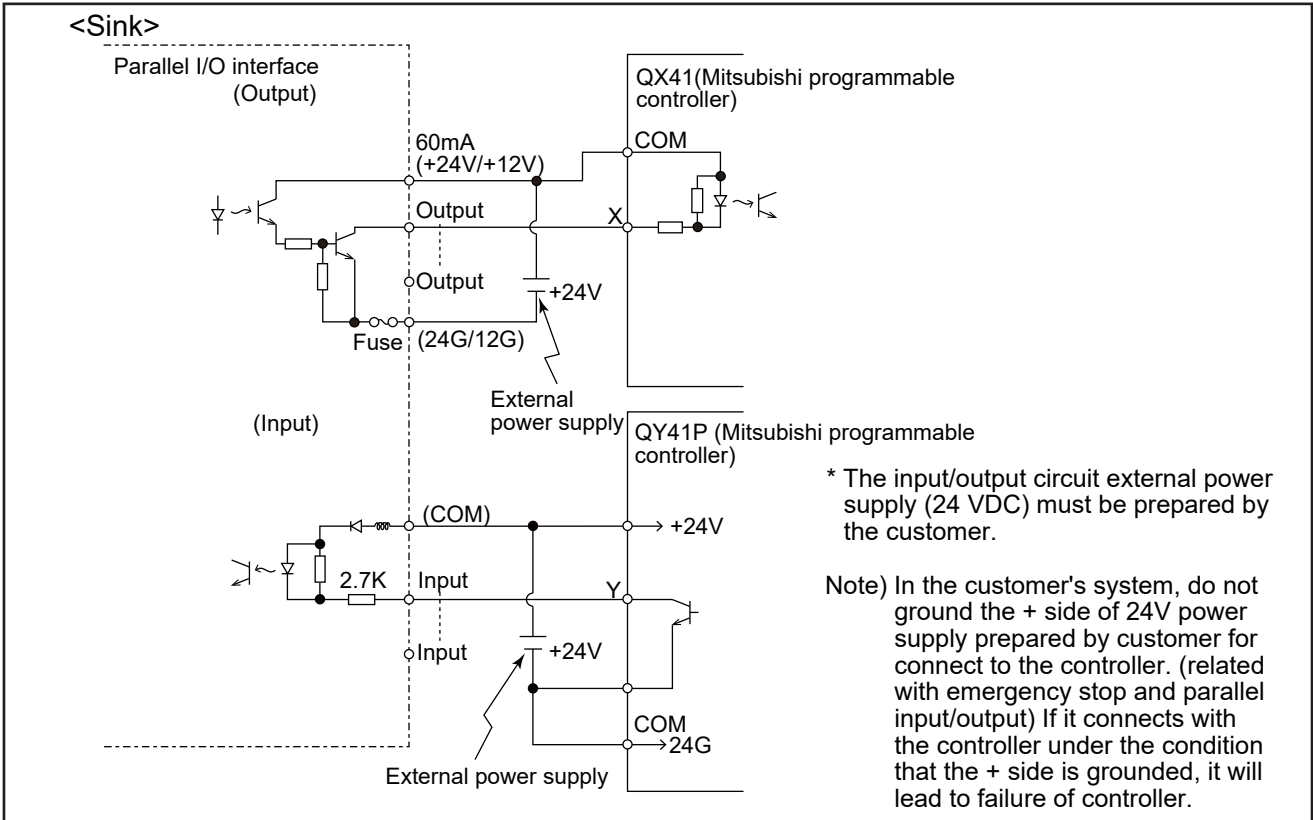

Fig.: Connection with a Mitsubishi PLC (Example of sink type)
The following shows an example of a protective circuit.

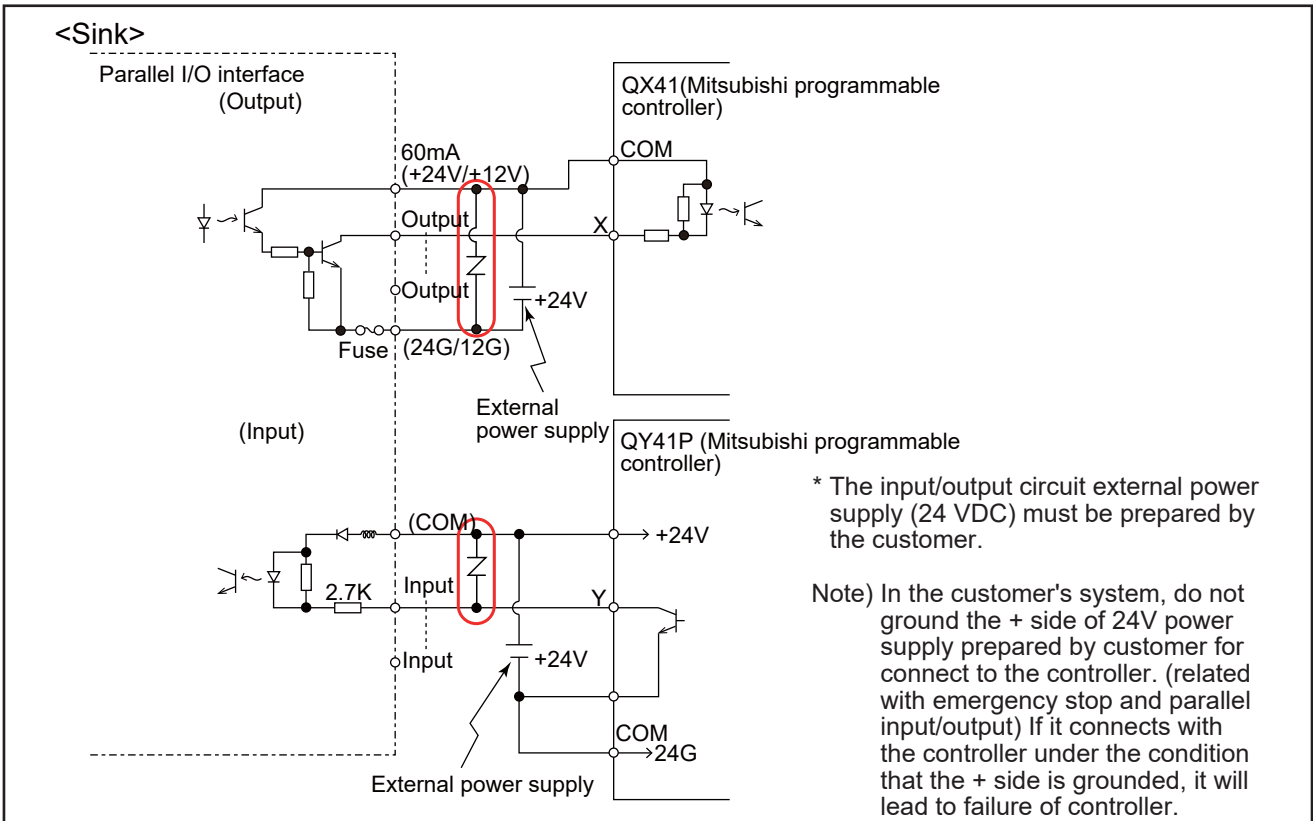

Fig.: Connection with a Mitsubishi PLC (Example of sink type) for use of a protective circuit

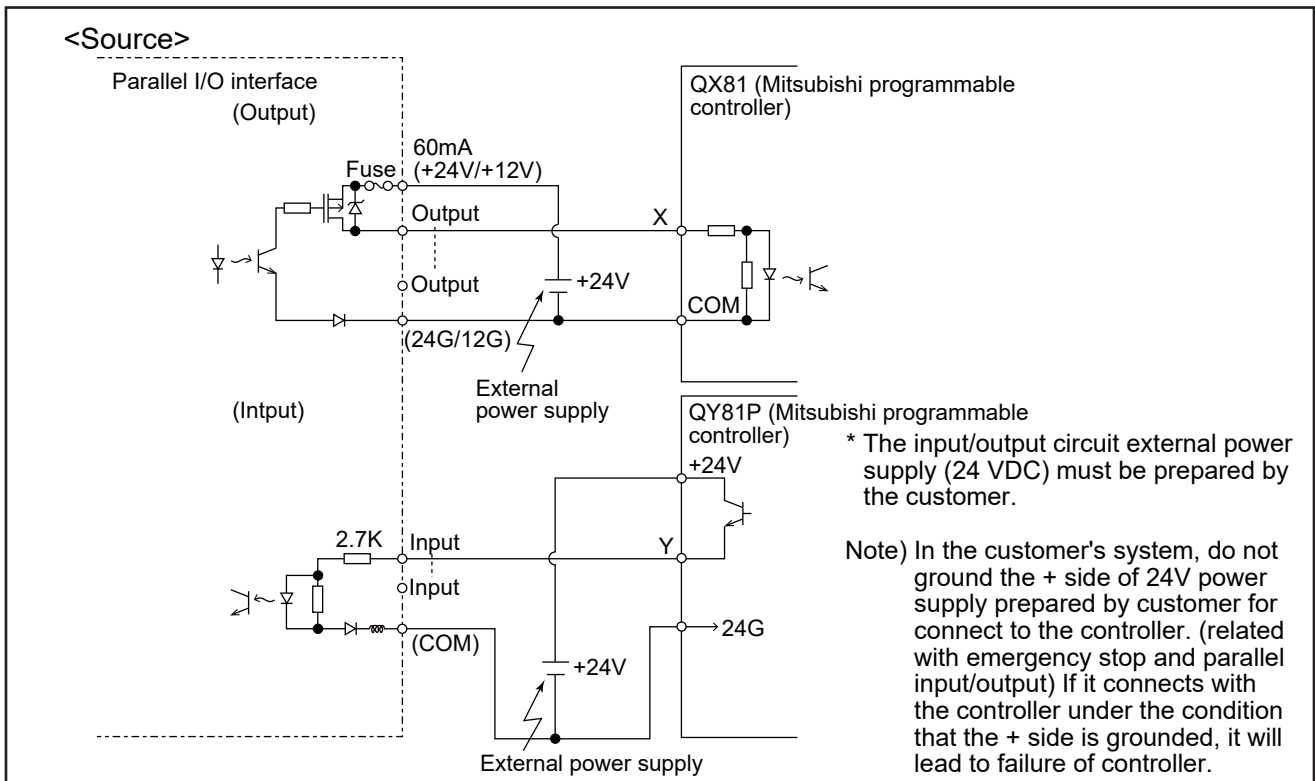

Fig.: Connection with a Mitsubishi PLC (Example of source type)

The following shows an example of a protective circuit.

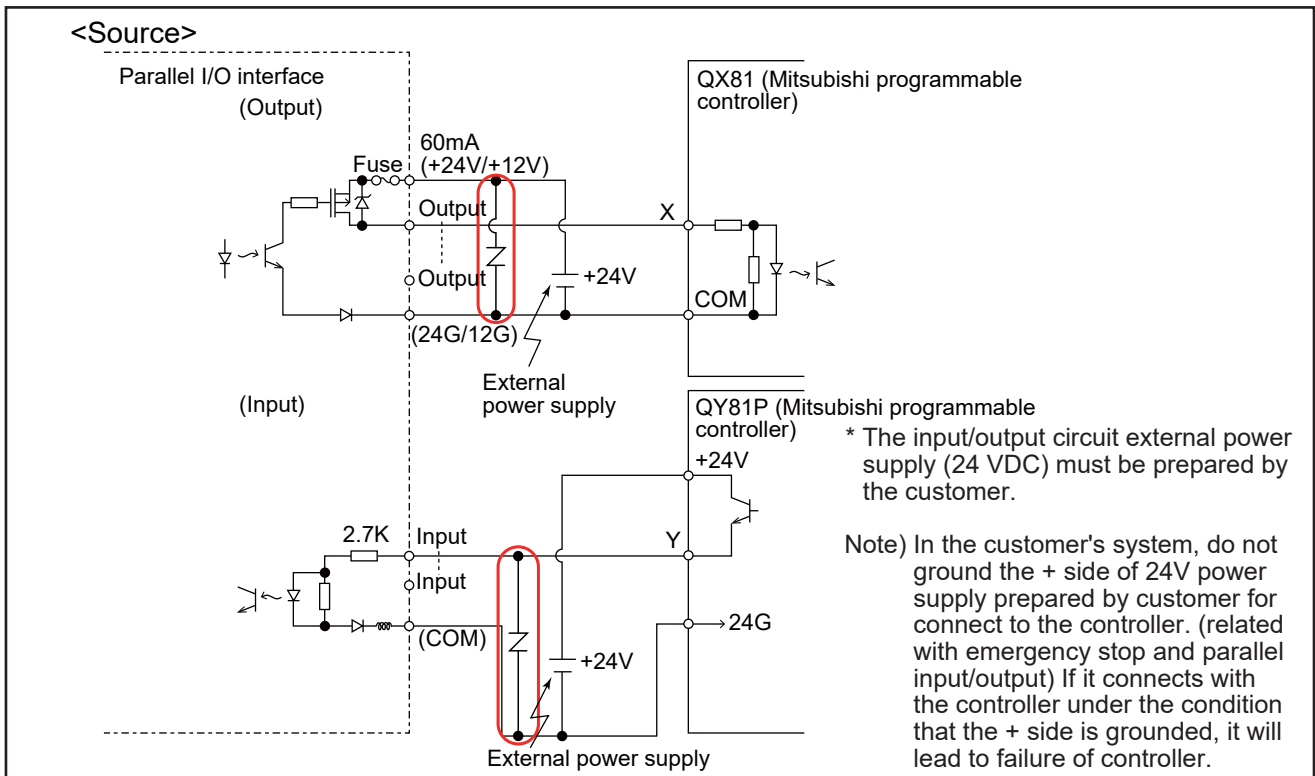

Fig.: Connection with a Mitsubishi PLC (Example of source type) for use of a protective circuit

External I/O cable

Order type

●2D-CBL□□

Note) The numbers in the boxes □□ refer to the length.(05: 5m, 15: 15m)

Outline



This is the dedicated cable used to connect an external peripheral device to the connector on the parallel I/O interface. For parallel I/O unit is another option 2A-CBL**.

One end matches the connector on the parallel input/output unit, and the other end is free. Connect the peripheral device's input/output signal using the free end.

One cable correspond to the input 16 points and output 16 points.

Two cables are needed to connection of (input 32 points and output 32 points) with built-in standard.

Configuration

Table: Configuration device

Part name	Type	Qty.	Mass (kg) *1	Remarks
External I/O cable	2D-CBL□□	1 pc.	0.7(5m) 1.84(15m)	5m or 15m

*1 Mass indicates one set.

Specifications

Table: Specifications

Items	Specifications
Number of cables x cable size	AWG #28 x 20P(40 cores)
Total length	5m, 15m

Connector pin numbers and cable colors

Table: Connector pin numbers and cable colors

Pin No.	Cable colors	Pin No.	Cable colors	Pin No.	Cable colors	Pin No.	Cable colors
1A/C	Orange/Red a	11A/C	Orange/Red c	1B/D	Orange/Black a	11B/D	Orange/Black c
2A/C	Gray/Red a	12A/C	Gray/Red c	2B/D	Gray/Black a	12B/D	Gray/Black c
3A/C	White/Red a	13A/C	White/Red c	3B/D	White/Black a	13B/D	White/Black c
4A/C	Yellow/Red a	14A/C	Yellow/Red c	4B/D	Yellow/Black a	14B/D	Yellow/Black c
5A/C	Pink/Red a	15A/C	Pink/Red c	5B/D	Pink/Black a	15B/D	Pink/Black c
6A/C	Orange/Red b	16A/C	Orange/Red d	6B/D	Orange/Black b	16B/D	Orange/Black d
7A/C	Gray/Red b	17A/C	Gray/Red d	7B/D	Gray/Black b	17B/D	Gray/Black d
8A/C	White/Red b	18A/C	White/Red d	8B/D	White/Black b	18B/D	White/Black d
9A/C	Yellow/Red b	19A/C	Yellow/Red d	9B/D	Yellow/Black b	19B/D	Yellow/Black d
10A/C	Pink/Red b	20A/C	Pink/Red d	10B/D	Pink/Black b	20B/D	Pink/Black d

Notes) Pin number of connector<1> are 1C, 2C,20C, 1D, 2D,20D, connector<2> are 1A, 2A,20A, 1B, 2B,20B.

■Connections and outside dimensions

The sheath of each signal cable (40 lines) is color indicated and marked with dots. Refer to the cable color specifications in

☞ Table: Connector pin numbers and cable colors when making the connections.

(Eg.) Pin number: color indication

1 : Orange/Red/a

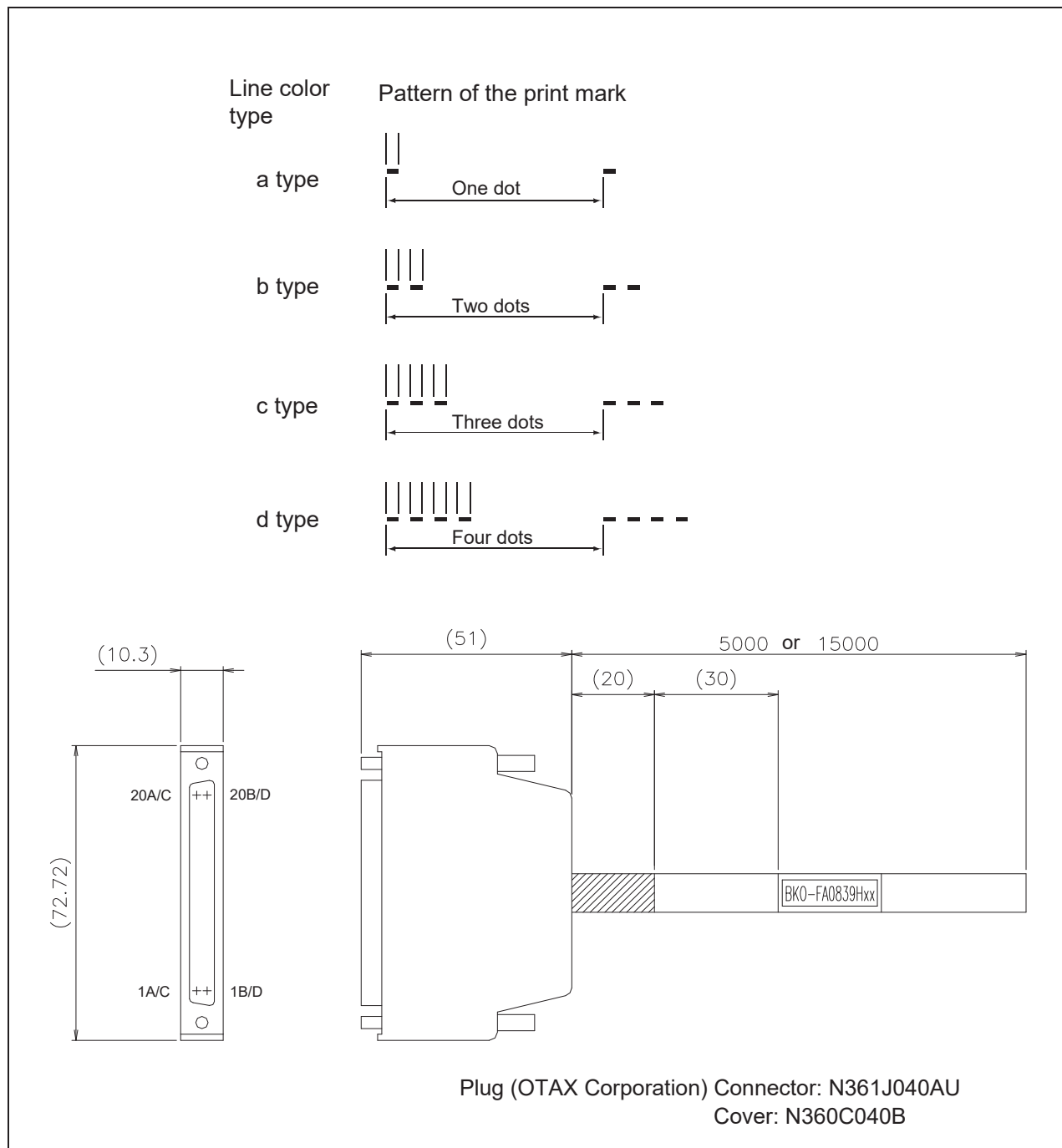
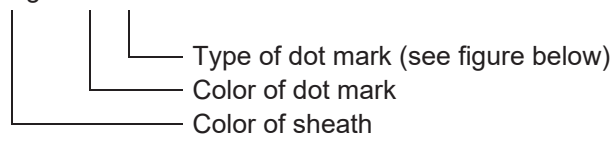

Fig.: Connections and outside dimensions

Parallel I/O unit

Order type

- 2A-RZ361 (Sink type)/2A-RZ371 (Source type)

Outline



This is used to expand the external inputs and outputs.

- The connection cable is not included. Prepare the optional external input/output cable (2A-CBL05 or 2A-CBL15).
- Use 2A-RZ361 if the external input/output signal logic is of the sink type and 2A-RZ371 for source type signal logic.

Notes) Although the combined use with the parallel I/O interface (2D-TZ368/2D-TZ378) of another option is also possible, please use the setup of the station number by the different number separately. The station number is automatically fixed by the position of the option slot which installed the parallel I/O interface in 0-1.

Configuration

Table: Configuration device

Part name	Type	Qty.	Mass (kg) *1	Remarks
Parallel I/O unit	2A-RZ361	Either one pc.	0.7	Input/output 32 points/32 points 2A-RZ361 is the sink type. 2A-RZ371 is the source type.
	2A-RZ371			
Robot I/O link connection connector	NETcable-1	2 sets	-	Connector with pins. The cable must be prepared and wired by the customer.
Power connection connector	DCcable-2	Each 1 set	-	Connector with pins. The cable must be prepared and wired by the customer.
Terminator	R-TM	1 pc.	-	100Ω(1/4W)

*1 Mass indicates one set.

Specifications

1) Up to eight stations can be connected to this unit (one station occupies one unit).

The combined use with another optional parallel I/O interface (2D-TZ368/2D-TZ378) is possible, but the maximum number of stations is eight in total. In this case, set any of station numbers carefully so that they do not duplicate.

2) The power supply (24V) must be prepared by the customer and connected with the power connection cable (DCcable-2)

A separate 24V power supply is required for the input/output circuit wiring.

Table: Electrical specifications of input circuits

Item	Specification	Internal circuit	
Type	DC input	<p><Sink type></p> <p><Source type></p>	
Number of input points	32		
Insulation method	Photo coupler insulation		
Rated input voltage	12VDC		24VDC
Rated input current	Approx 3mA		Approx 7mA
Working voltage range	10.2 to 26.4VDC (Ripple factor should be less than 5%.)		
ON voltage/ON current	8VDC or more/ 2mA or more		
OFF voltage/ OFF current	4VDC or less/ 1mA or less		
Input resistance	Approx. 3.3kΩ		
Response time	OFF-ON		10ms or less (24VDC)
	ON-OFF		10ms or less (24VDC)
Common method	8 points per common		
External cable connection method	Connector		

Table: Electrical specifications for the output circuits

Item		Specification	Internal circuit
Type		Transistor output	<p><Sink type></p> <p><Source type></p>
No. of output points		32	
Insulation method		Photo-coupler insulation	
Rated load voltage		12VDC/24VDC	
Rated load voltage range		10.2 to 30VDC(peak voltage 30VDC)	
Max. load current		0.1A/point (100%)	
Leakage current at OFF		0.1mA or less	
Max. voltage drop at ON		0.9VDC(TYP.) *1	
Response time	OFF-ON	2ms or less (hardware response time)	
	ON-OFF	2ms or less (Resistance load) (hardware response time)	
Fuse rating		Fuse 3.2A (one per common) Replacement not possible	
Common method		8 points per common (common terminal: 4 points)	
External wire connection method		Connector	
External power supply	Voltage	12VDC/24VDC(10.2 to 30VDC)	
	Current	60mA (TYP. 24VDC per common) (base drive current)	

*1 The maximum voltage drop value at signal ON.
Refer to it for the equipment connected to the output circuit.

*A voltage exceeding the rated voltage or incorrect wiring may damage the circuit.

⚠ CAUTION

The output circuit protective fuses prevent failure in case of load short-circuit and improper connections. Please do not connect loads that cause the current to exceed the maximum rated current. If the maximum rated current is exceeded, the internal transistors may be damaged.

⚠ CAUTION

Inputs the power supply for control (DCcable-2) then inputs the controller's power supply.

NET cable-1 (Network cable)

Pin No.	RIO1/2
1	TXRXH
2	TXRXL
3	SG(GND)

Connector: 1-178288-3

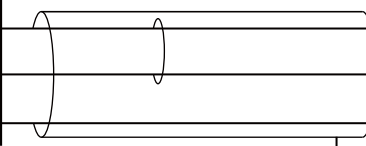

RIO	Pin No.
TXRXDH	1A
TXRXDL	1B
SG(GND)	2B
FG	3A

Connector: J21DF-06V-KX-L

DCcable-2 (Power cable)

Pin No.	RIO1/2
1	24V
2	24G(RG)
3	FG(PE)

Connector: 2-178288-3

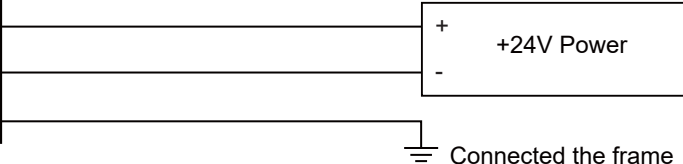

Connected the frame ground or protect ground

R-TM (Terminator)

Pin No.	RIO1/2
1	TXRXH
2	TXRXL
3	SG(GND)

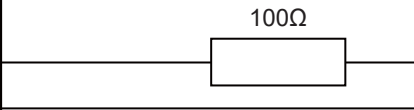

List of parts and manufacturer

Type	Connector type	Contact type	Resistant	Manufacturer
NETcable-1	1-178288-3 (2)	1-175218-2 (6)	-	Tyco Electronics
	51103-0300 (1)	50351-8100 (3)	-	MOLEX
	J21DF-06V-KX-L(1)	SJ2F-01GF-P1.0(4)	-	JST
DCcable-2	2-178288-3 (1)	1-175218-5 (3)	-	Tyco Electronics
R-TM	1-178288-3 (1)	1-175218-3 (2)	100Ω(1/4W) (1)	Equivalent to KOA.

Note 1) The 24V power supply is prepared by customer (The power consumption is approx. 0.3A.)

In the customer's system, do not ground the + side of 24V power supply prepared by customer for connect to the controller. (related with emergency stop and parallel input/output) If it connects with the controller under the condition that the + side is grounded, it will lead to failure of controller.

Note 2) The cable for general purpose can be used to the network cable. However, use the twisted shield cable of AWG#22 (0.3mm²) or more.

Fig.: Specifications for the connection cable

■ Installation method

The expansion parallel input/output unit is installed outside of the controller. Connect with the network connection cable (NETcable-1) from the RIO connector in the front of the controller.

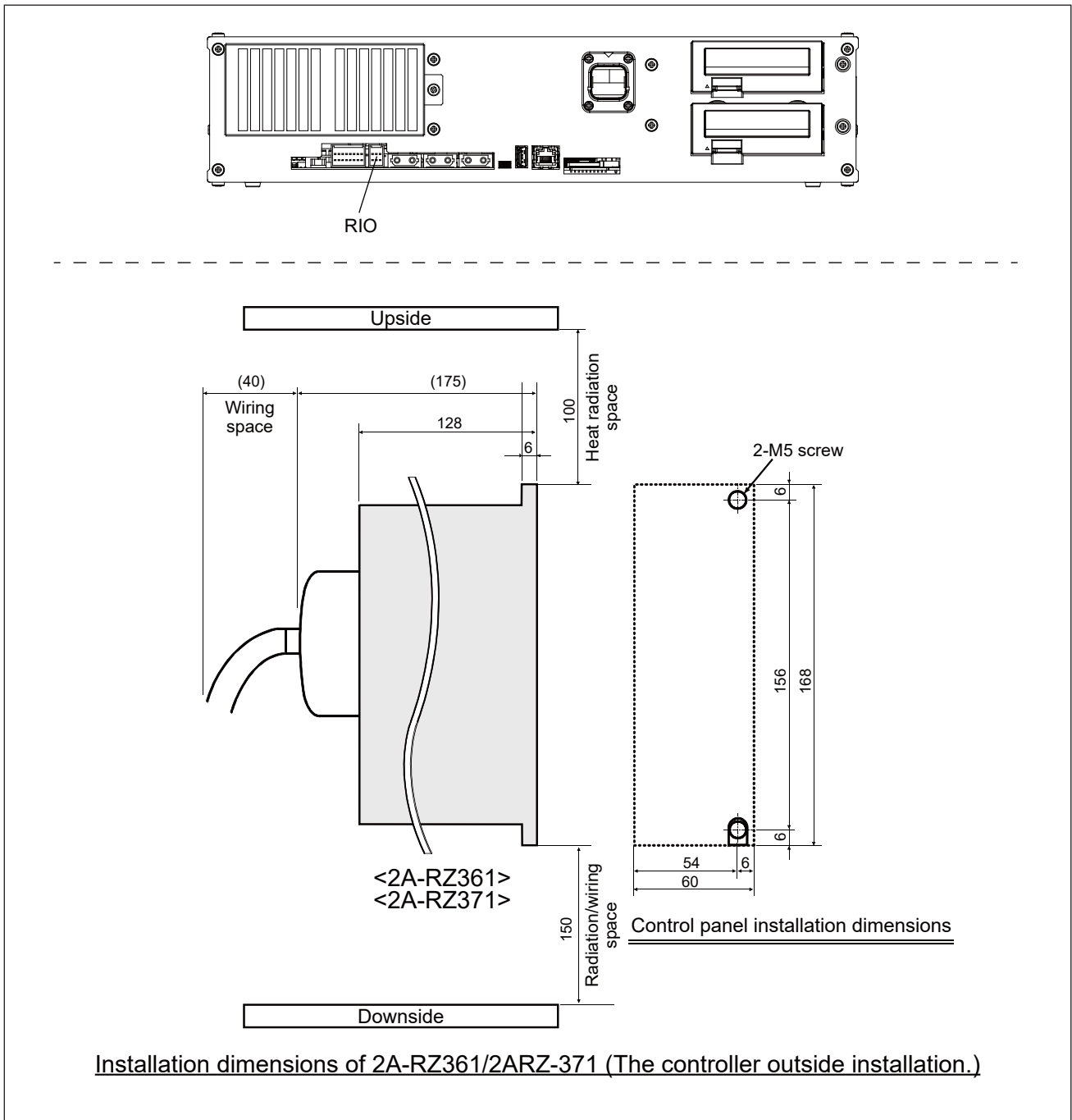

Fig.: Installing the parallel I/O unit

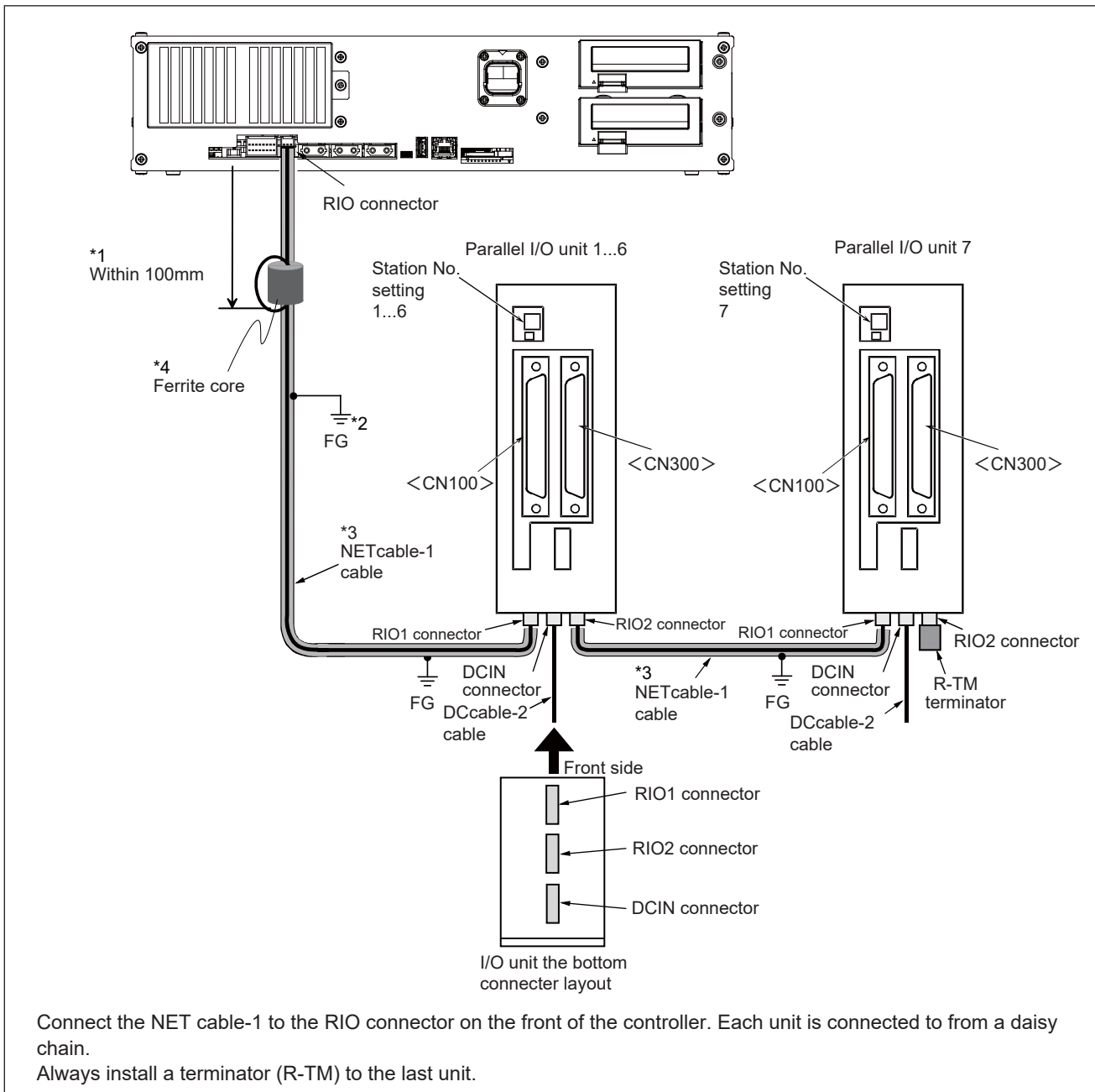
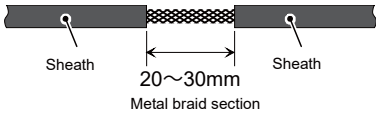

Fig.: Connection method of expansion parallel I/O unit

- *1 Install the ferrite core in within 100mm from each connector.
- *2 Grounding terminal position



Peel the sheath in the position about 200-300mm from the connector end of the cable, so you can install and remove the cover.
* Don't damage the shield line.

- *3 Use a shield cable for NET cable-1 as a measure against noise.
The unit could malfunction because of noise if the shield cable is not used.
Always connect the shield to FG. Install the attached ferrite core in both ends.
- *4 Install the ferrite core on the cable as required.
Recommended ferrite core: E04SR301334 (manufacture: SEIWA ELECTRIC MFG)

Pin arrangement of the connector

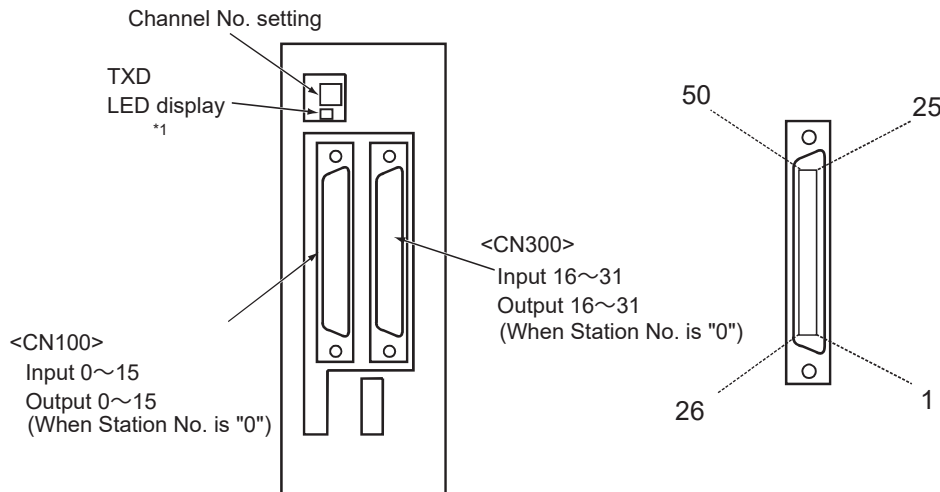

Fig.: Pin arrangement of the parallel I/O unit

*2A-RZ361/2 A-RZ371 are 32/32 input-and-output units. (One-station occupancy)

*1 TXD LED display

Indicator for the communication status. The dimly lit lamp indicates that the unit is in the normal condition. The brightness of the light depends on the communication conditions.

Assignment of pin number and signal

The assignment range of the general-purpose input-and-output signal is fixed by the setup of the station number.

Although the combined use with the parallel I/O interface (2D-TZ368/2D-TZ378) of another option is also possible, please use the setup of the station number by the different number separately.

Table: Assignment of pin number and signal

Unit Number	Station number	CN100	CN300
1st set	0	Input: 0 to 15 Output: 0 to 15	Input : 16 to 31 Output : 16 to 31
2nd set	1	Input: 32 to 47 Output: 32 to 47	Input : 48 to 63 Output : 48 to 63
3rd set	2	Input: 64 to 79 Output: 64 to 79	Input : 80 to 95 Output : 80 to 95
4th set	3	Input: 96 to 111 Output: 96 to 111	Input : 112 to 127 Output : 112 to 127
5th set	4	Input: 128 to 143 Output: 128 to 143	Input : 144 to 159 Output : 144 to 159
6th set	5	Input: 160 to 175 Output: 160 to 175	Input : 176 to 191 Output : 176 to 191
7th set	6	Input: 192 to 207 Output : 192 to 207	Input : 208 to 223 Output : 208 to 223
8th set	7	Input: 224 to 239 Output: 224 to 239	Input : 240 to 255 Output : 240 to 255

The connector pin number of the parallel I/O unit of the station number 0 and signal number assignment are shown in

☞ Table: Connector CN100pin No. and signal assignment list (2A-CBL□□) and ☞ Table: Connector CN300pin No. and signal assignment list (2A-CBL□□). If it is set as other station number, please interpret and utilize.

Table: Connector CN100pin No. and signal assignment list (2A-CBL□□)

Pin No.	Line color	Function name		Pin No.	Line color	Function name	
		General-purpose	Dedicated/power supply, common			General-purpose	Dedicated/power supply, common
1	Orange/Red A		FG	26	Orange/Blue A		FG
2	Gray/Red A		0V:For pins 4-7, 10-13	27	Gray/Blue A		0V:For pins 29-32, 35-38
3	White/Red A		12V/24V:For pins 4-7	28	White/Blue A		12V/24V:For pins 29-32
4	Yellow/Red A	General-purpose output 0	Operating output *1	29	Yellow/Blue A	General-purpose output 4	
5	Pink/Red A	General-purpose output 1	In servo ON output signal *1	30	Pink/Blue A	General-purpose output 5	
6	Orange/Red B	General-purpose output 2	Error occurring output signal *1	31	Orange/Blue B	General-purpose output 6	
7	Gray/Red B	General-purpose output 3	Operation rights output signal *1	32	Gray/Blue B	General-purpose output 7	
8	White/Red B		0V:For pins 4-7, 10-13	33	White/Blue B		0V:For pins 29-32, 35-38
9	Yellow/Red B		12V/24V:For pins 10-13	34	Yellow/Blue B		12V/24V:For pins 35-38
10	Pink/Red B	General-purpose output 8		35	Pink/Blue B	General-purpose output 12	
11	Orange/Red C	General-purpose output 9		36	Orange/Blue C	General-purpose output 13	
12	Gray/Red C	General-purpose output 10		37	Gray/Blue C	General-purpose output 14	
13	White/Red C	General-purpose output 11		38	White/Blue C	General-purpose output 15	
14	Yellow/Red C		COM0:For pins 15-22 *2	39	Yellow/Blue C		COM1:For pins 40-47 *2
15	Pink/Red C	General-purpose input 0	Stop input *3	40	Pink/Blue C	General-purpose input 8	
16	Orange/Red D	General-purpose input 1	Servo OFF input signal *1	41	Orange/Blue D	General-purpose input 9	
17	Gray/Red D	General-purpose input 2	Error reset input signal *1	42	Gray/Blue D	General-purpose input 10	
18	White/Red D	General-purpose input 3	Start input *1	43	White/Blue D	General-purpose input 11	
19	Yellow/Red D	General-purpose input 4	Servo ON input signal *1	44	Yellow/Blue D	General-purpose input 12	
20	Pink/Red D	General-purpose input 5	Operation rights input signal *1	45	Pink/Blue D	General-purpose input 13	
21	Orange/Red E	General-purpose input 6		46	Orange/Blue E	General-purpose input 14	
22	Gray/Red E	General-purpose input 7		47	Gray/Blue E	General-purpose input 15	
23	White/Red E		Reserved	48	White/Blue E		Reserved
24	Yellow/Red E		Reserved	49	Yellow/Blue E		Reserved
25	Pink/Red E		Reserved	50	Pink/Blue E		Reserved

*1 The dedicated signal is assigned at shipping. It can change with the parameter.

*2 Sink type:12V/24V(COM),Source type:0V(COM)

*3 The dedicated input signal (STOP) is assigned at shipping. The signal number is fixing.

Table: Connector CN300pin No. and signal assignment list (2A-CBL□□)

Pin No.	Line color	Function name		Pin No.	Line color	Function name	
		General-purpose	Dedicated/power supply, common			General-purpose	Dedicated/power supply, common
1	Orange/Red A		FG	26	Orange/Blue A		FG
2	Gray/Red A		0V:For pins 4-7, 10-13	27	Gray/Blue A		0V:For pins 29-32, 35-38
3	White/Red A		12V/24V:For pins 4-7	28	White/Blue A		12V/24V:For pins 29-32
4	Yellow/Red A	General-purpose output 16		29	Yellow/Blue A	General-purpose output 20	
5	Pink/Red A	General-purpose output 17		30	Pink/Blue A	General-purpose output 21	
6	Orange/Red B	General-purpose output 18		31	Orange/Blue B	General-purpose output 22	
7	Gray/Red B	General-purpose output 19		32	Gray/Blue B	General-purpose output 23	
8	White/Red B		0V:For pins 4-7, 10-13	33	White/Blue B		0V:For pins 29-32, 35-38
9	Yellow/Red B		12V/24V:For pins 10-13	34	Yellow/Blue B		12V/24V:For pins 35-38
10	Pink/Red B	General-purpose output 24		35	Pink/Blue B	General-purpose output 28	
11	Orange/Red C	General-purpose output 25		36	Orange/Blue C	General-purpose output 29	
12	Gray/Red C	General-purpose output 26		37	Gray/Blue C	General-purpose output 30	
13	White/Red C	General-purpose output 27		38	White/Blue C	General-purpose output 31	
14	Yellow/Red C		COM0:For pins 15-22*1	39	Yellow/Blue C		COM1:For pins 40-47*1
15	Pink/Red C	General-purpose input 16		40	Pink/Blue C	General-purpose input 24	
16	Orange/Red D	General-purpose input 17		41	Orange/Blue D	General-purpose input 25	
17	Gray/Red D	General-purpose input 18		42	Gray/Blue D	General-purpose input 26	
18	White/Red D	General-purpose input 19		43	White/Blue D	General-purpose input 27	
19	Yellow/Red D	General-purpose input 20		44	Yellow/Blue D	General-purpose input 28	
20	Pink/Red D	General-purpose input 21		45	Pink/Blue D	General-purpose input 29	
21	Orange/Red E	General-purpose input 22		46	Orange/Blue E	General-purpose input 30	
22	Gray/Red E	General-purpose input 23		47	Gray/Blue E	General-purpose input 31	
23	White/Red E		Reserved	48	White/Blue E		Reserved
24	Yellow/Red E		Reserved	49	Yellow/Blue E		Reserved
25	Pink/Red E		Reserved	50	Pink/Blue E		Reserved

*1 Sink type: 12V/24V(COM), Source type: 0V(COM)

<Reference> The example of connection with our PLC

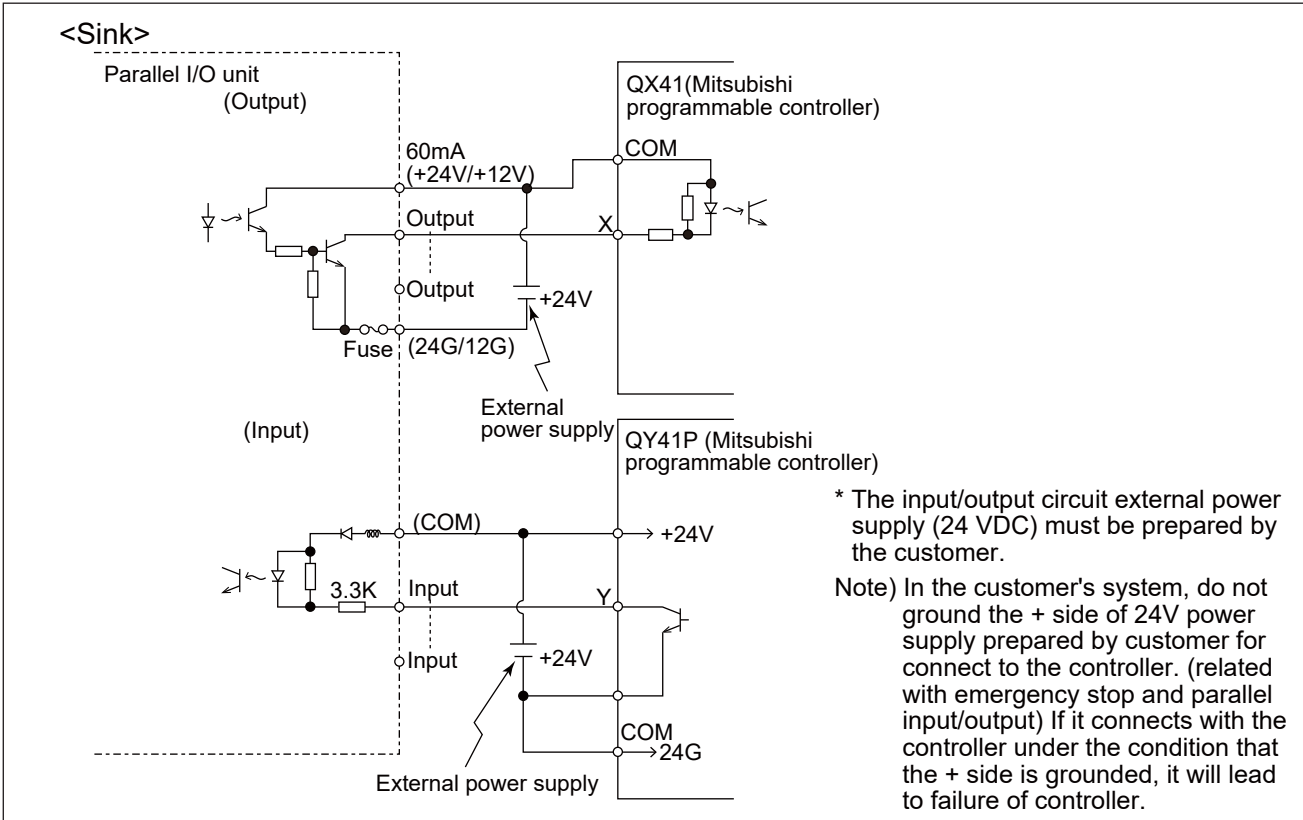

Fig.: Connection with a Mitsubishi PLC (Example of sink type)

The following shows an example of a protective circuit.

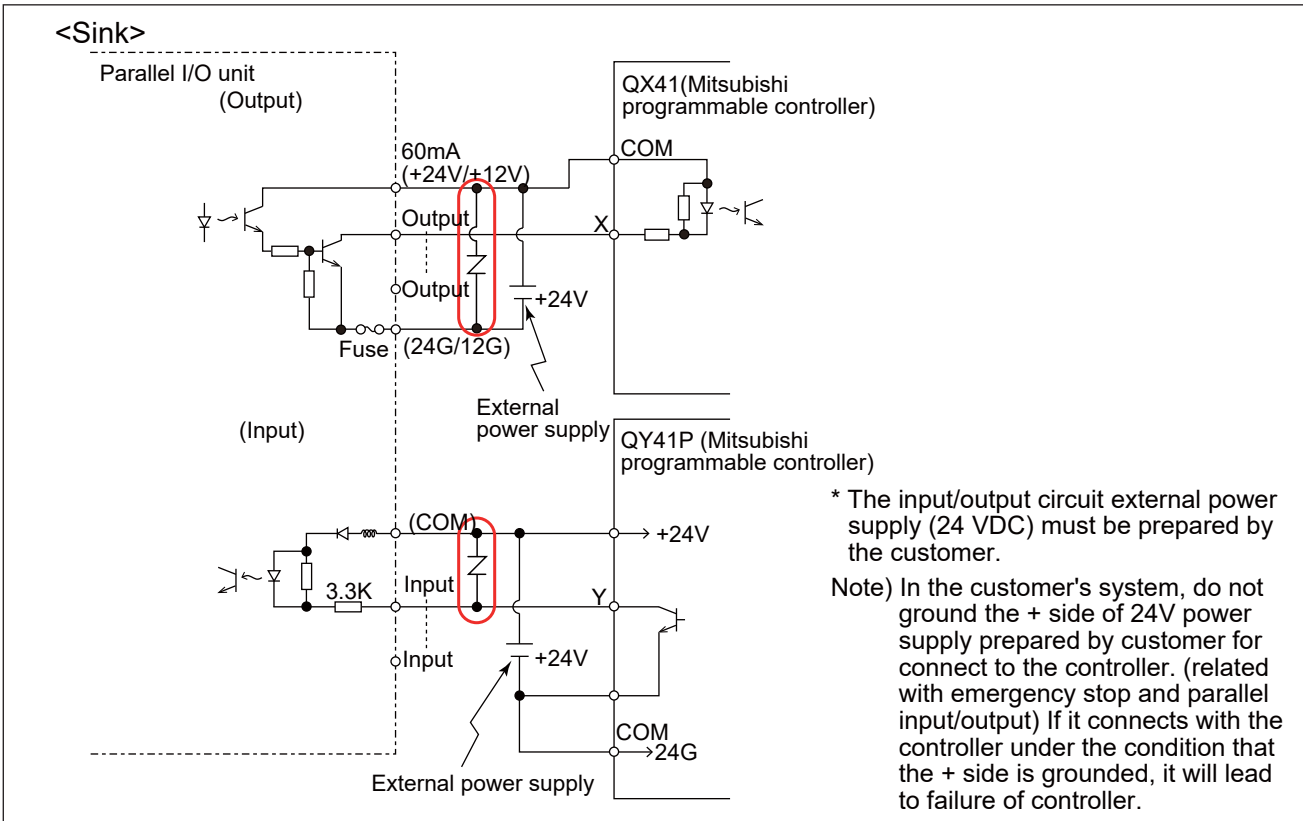

Fig.: Connection with a Mitsubishi PLC (Example of sink type) for use of a protective circuit

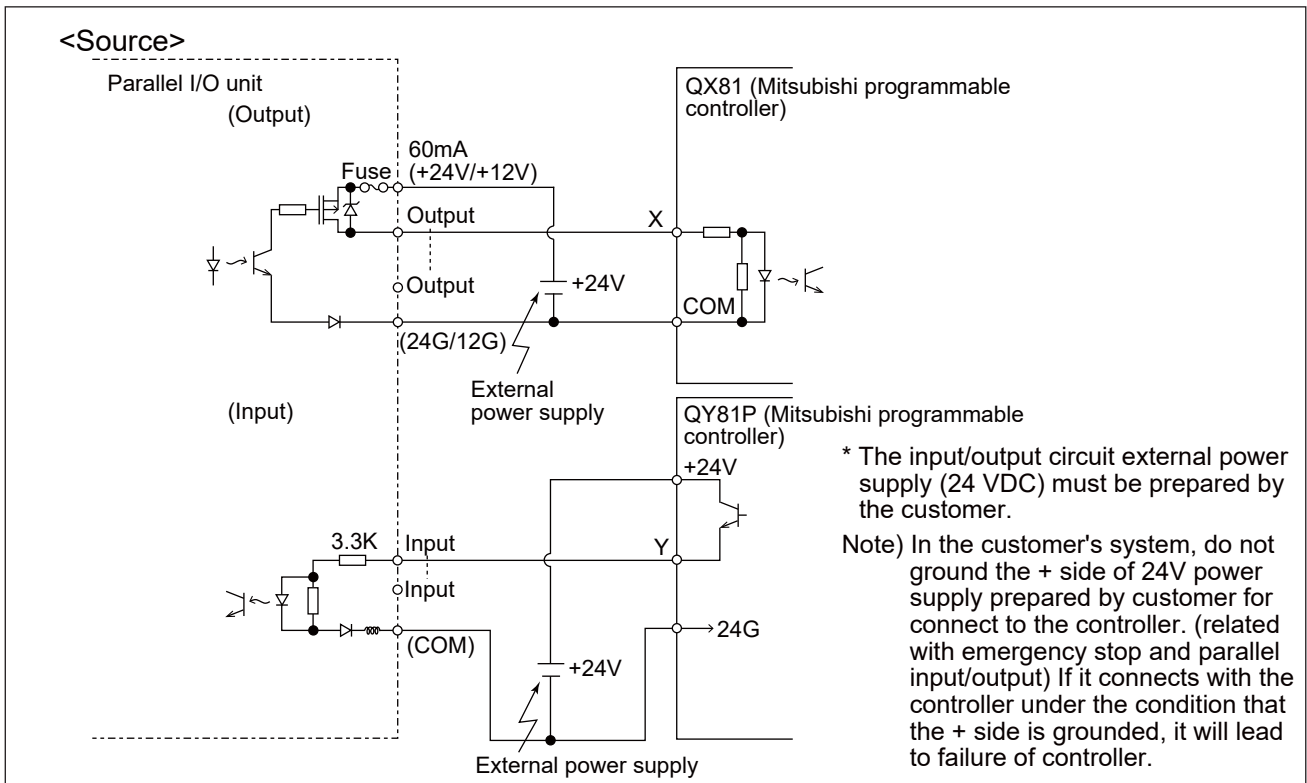

Fig.: Connection with a Mitsubishi PLC (Example of source type)
The following shows an example of a protective circuit.

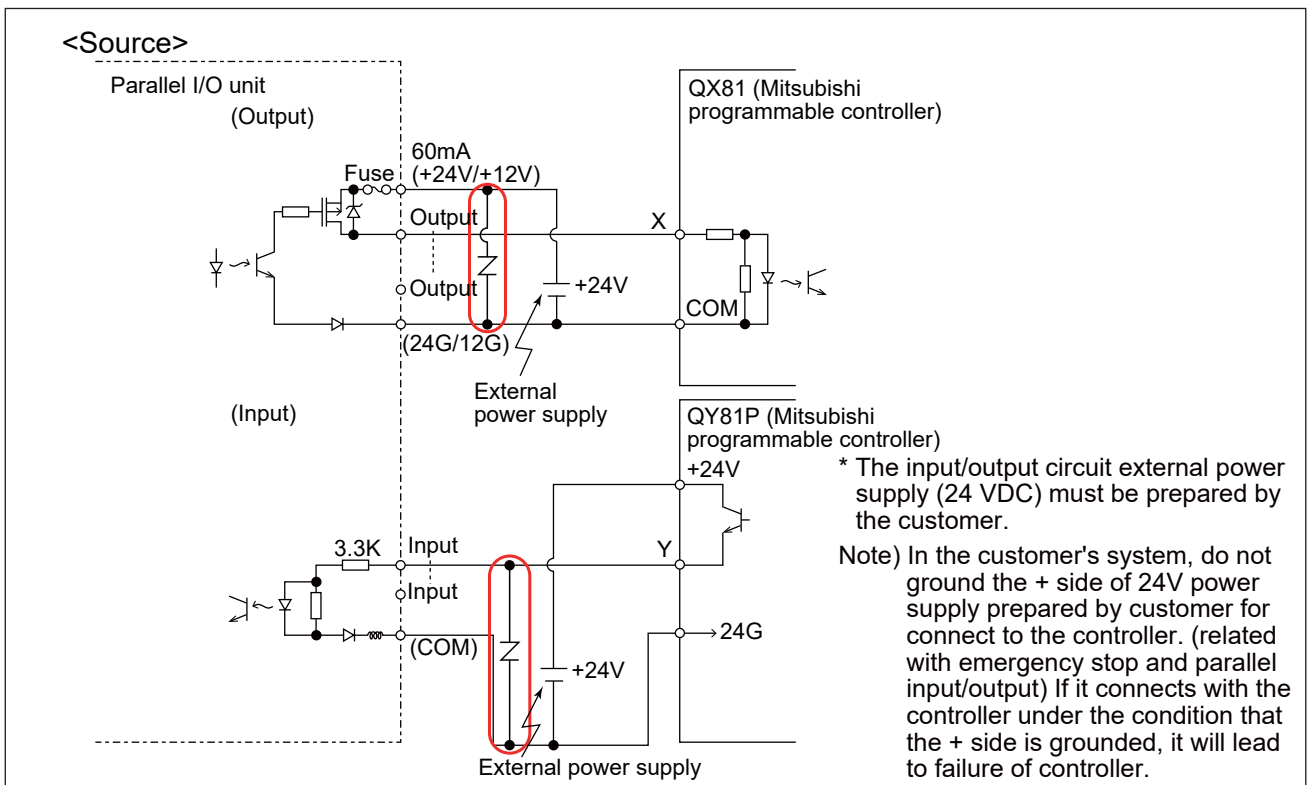

Fig.: Connection with a Mitsubishi PLC (Example of source type) for use of a protective circuit

External I/O cable

■Order type

●2A-CBL□□

Note) The numbers in the boxes □□ refer to the length.(05: 5m:15: 15m)

■Outline



This is the dedicated cable used to connect an external peripheral device to the connector on the parallel input/output unit. One end matches the connector on the parallel input/output unit, and the other end is free. Connect the peripheral device's input/output signal using the free end.

One cable correspond to the input 16 points and output 16 points.

Two cables are needed to connection of (input 32 points and output 32 points) with built-in standard.

■Configuration

Table: Configuration device

Part name	Type	Qty.	Mass(kg) *1	Remarks
External I/O cable	2A-CBL□□	1pc.	0.7(5m) 1.84(15m)	5m or 15m

*1 Mass indicates one set.

■Specifications

Table: Specifications

Items	Specifications
Number of cables x cable size	50 cores x AWG #28
Total length	5m or 15m

■Connector pin numbers and cable colors

Table: Connector pin numbers and cable colors

Pin No.	Cable colors	Pin No.	Cable colors	Pin No.	Cable colors	Pin No.	Cable colors	Pin No.	Cable colors
1	Orange/Red A	11	Orange/Red C	21	Orange/Red E	31	Orange/Blue B	41	Orange/Blue D
2	Gray/Red A	12	Gray/Red C	22	Gray/Red E	32	Gray/Blue B	42	Gray/Blue D
3	White/Red A	13	White/Red C	23	White/Red E	33	White/Blue B	43	White/Blue D
4	Yellow/Red A	14	Yellow/Red C	24	Yellow/Red E	34	Yellow/Blue B	44	Yellow/Blue D
5	Pink/Red A	15	Pink/Red C	25	Pink/Red E	35	Pink/Blue B	45	Pink/Blue D
6	Orange/Red B	16	Orange/Red D	26	Orange/Blue A	36	Orange/Blue C	46	Orange/Blue E
7	Gray/Red B	17	Gray/Red D	27	Gray/Blue A	37	Gray/Blue C	47	Gray/Blue E
8	White/Red B	18	White/Red D	28	White/Blue A	38	White/Blue C	48	White/Blue E
9	Yellow/Red B	19	Yellow/Red D	29	Yellow/Blue A	39	Yellow/Blue C	49	Yellow/Blue E
10	Pink/Red B	20	Pink/Red D	30	Pink/Blue A	40	Pink/Blue C	50	Pink/Blue E

■Connections and outside dimensions

The sheath of each signal cable (50 lines) is color indicated and marked with dots.

Refer to the cable color specifications in  when making the connections.

(Eg.) Pin number: color indication

1 : Orange/Red/a

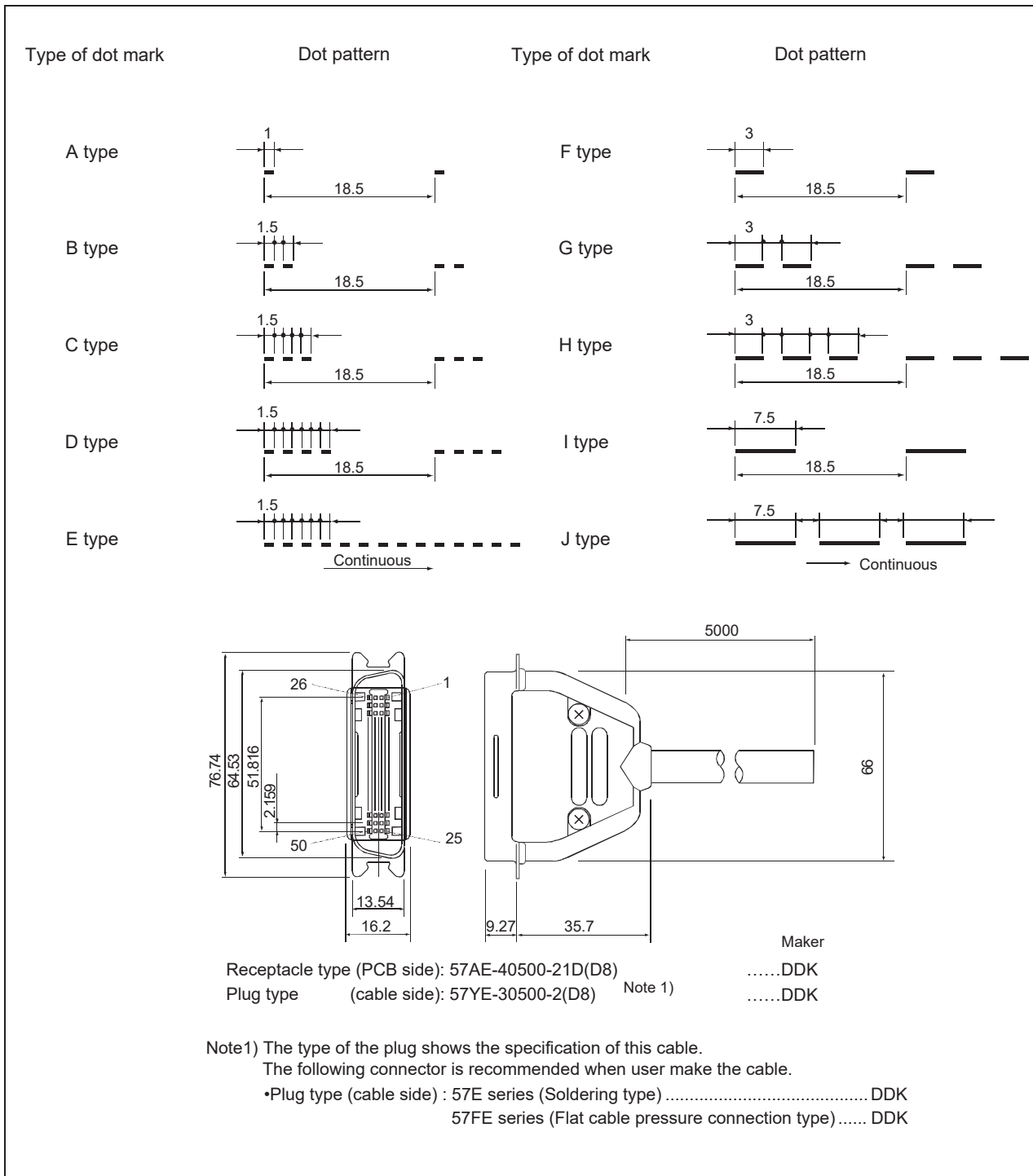
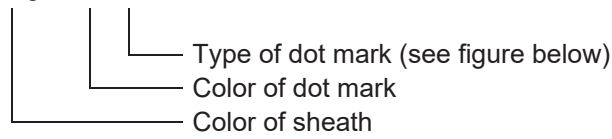

Fig.: Connections and outside dimensions

CC-Link interface

Order type

●2D-TZ576

Outline



The CC-Link interface is the option interface to not only add bit data to the robot controller, but also to add CC-Link field network function that allows cyclic transmission of word data.

Configuration

Table: Configuration device

Part name	Type	Qty.	Mass(kg) *1	Remarks
CC-Link interface	TZ576	1	0.6	
Manual	BFP-A8634	1	—	CD-ROM
Ferrite core	E04SR301334	2	—	Be sure to install this for noise countermeasure.
Cable clamp	AL4	2	—	
	AL5	2	—	
On-line connector for communication	A6CON-LJ5P	1	—	
Terminal resistor	A6CON-TR11N	1	—	Resistance value: 100Ω
One-touch connector plug for communication	A6CON-L5P	2	—	

*1 Mass indicates one set.

Table: Procured by the customer

Part name	Type	Qty.	Remarks
Master station	FX3U-16CCL-M (FX series)	1	
	RJ61BT11 (R series)		
	QJ61BT11 (Q series)		
	QJ61BT11N (Q series)		
	AJ61QBT11 (QnA series)		
	A1SJ61QBT11 (QnAS series)		
	AJ61BT11 (A series)		
	A1SJ61BT11 (AnS series)		
	A80BD-J61BT11 (personal computer board)		
Communication cable	—	1	Ddedicated cable

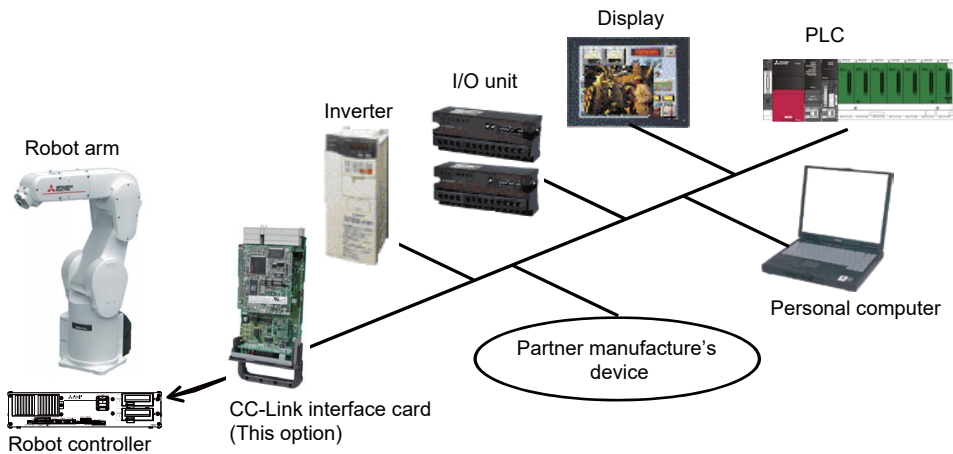

Fig.: Example of CC-Link Product Configuration

■ Specifications

Table: Specifications

Item		Specifications				Remarks
Communication function		Bit data and word data can be transmitted.				Word data are used by the registers.
Station type		Intelligent device station *1				
Support station		Local station				No master station function
The version corresponding to CC-Link		Ver.2				The extended cyclic setup is possible.
Mountable option slot		Slot 1, 2				
Number of mountable CC-Link interface cards		1				Multiple CC-Link interface cards cannot be inserted.
Number of stations		1 to 64 stations				When four stations are occupied, continuous station numbers are used. The station numbers are set by a DIP switch.
Transmission speed		10M/5M/2.5M/625K/156K bps				This is set by the rotary SW.
Station number		1 to 64				When two or more stations are occupied, continuous station numbers are used.
Number of occupied stations		1/2/3/4				
Extended cyclic setup		1/2/4/8				
Maximum link point		Remote I/O (RX, RY).	Each 896 points			The two last cannot be used.
		Remote register (RWr, RWw)	Each 128 register			
Extended cyclic setup		-	1 fold setup	2 fold setup	3 fold setup	4 fold setup
Link point per set	When one station is occupied	Remote I/O (RX, RY).	32 point	32 point	64 point	128 point
		Remote register (RWw)	4 word	8 word	16 word	32 word
		Remote register (RWr)	4 word	8 word	16 word	32 word
	When two stations is occupied	Remote I/O (RX, RY).	64 point	96 point	192 point	384 point
		Remote register (RWw)	8 word	16 word	32 word	64 word
		Remote register (RWr)	8 word	16 word	32 word	64 word
	When three stations is occupied	Remote I/O (RX, RY).	96 point	160 point	320 point	640 point
		Remote register (RWw)	12 word	24 word	48 word	96 word
		Remote register (RWr)	12 word	24 word	48 word	96 word
	When four stations is occupied	Remote I/O (RX, RY).	128 point	224 point	448 point	896 point
		Remote register (RWw)	16 word	32 word	64 word	128 word
		Remote register (RWr)	16 word	32 word	64 word	128 word
Number of the maximum occupancy station		4 stations				
The I/O first number of the robot controller.		No. 6000 - The number corresponding to the station number by the setup of the parameter "CCFIX."				

*1 Not available for the transient transmission function and FX-series models that do not support intelligent devices.

■Functions

(1) Communication function

- The number of usable points is 896 points maximum for bit control and 128 points maximum for word control.

(2) Easy setup

- The CC-Link interface card can be set by a rotary switch or DIP switch.
- No separate space is required to mount the CC-Link interface card as it is embedded in the robot controller (can only be mounted into slot 2).
- Easy wiring since only four terminals need to be connected.
- Dedicated commands have been added to MELFA-BASIC V, VI (robot programming language); thus, no complex interface programming is required.

(3) High-speed response

- The link scan time when connecting 64 stations is approximately 7.2 ms.
- A transmission speed can be selected from 10M, 5M, 2.5M, 625K and 156K bps according to the transmission distance.

SD memory card

■Order type

2F-2GBSD

■Outline



This card is used as an extended memory.

Insert this card to the slot (SD CARD) on the front of the controller, and store robot programs, logging data, or other data.

■Configuration

Table: Configuration device

Part name	Type	Qty.	Remarks
SD memory card	2F-2GBSD	1	Memory card capacity: 2GB

3.10 Maintenance parts

The consumable parts used in the controller are shown in  Table: Controller consumable parts list. Purchase these parts from your dealer when required. Some Mitsubishi-designated parts differ from the maker's standard parts. Thus, confirm the part name, robot arm and controller serial No. and purchase the parts from your dealer.

Table: Controller consumable parts list

No.	Name	Type *1	Qty.	Usage place	Supplier
1	Filter	BKOFA0773H42	1	Inside the filter cover	Mitsubishi Electric
2	Lithium battery	Q6BAT	1	Robot CPU unit: For Q172DSRCPU (CR800-Q controller only)	Mitsubishi Electric

*1 Confirm the robot arm serial No., and contact the dealer or service branch of Mitsubishi Electric Co., for the type.

4 Software

4.1 List of commands

The available new functions in MELFA-BASIC VI are given in  Table: List of MELFA-BASIC VI commands.

Table: List of MELFA-BASIC VI commands

Type	Class	Function	Input format (example)
Structured programming	Function procedure	Defines the Function procedure. Function procedure summarizes a series of processing enclosed by the Function statement and the FEnd statement.	Function M Func(M1, M2) M3=M1+M2 Func=M3 Exit Function FEnd
Library function	#Include statement	Reads the designated program.	#Include "PRG1"
Position and operation control	Joint interpolation	Moves to the designated position with joint interpolation.	Mov P1
	Linear interpolation	Moves to the designated position with linear interpolation.	Mvs P1
	Circular interpolation	Moves along a designated arc (start point→passing point→start point (end point)) with 3-dimensional circular interpolation (360 degrees).	Mvc P1,P2,P1
		Moves along a designated arc (start point→passing point→end point) with 3-dimensional circular interpolation.	Mvr P1,P2,P3
		Moves along the arc on the opposite side of a designated arc (start point→reference point→end point) with 3-dimensional circular interpolation.	Mvr2 P1,P9,P3
		Moves along a set arc (start point→end point) with 3-dimensional circular interpolation.	Mvr3 P1,P9,P3
	Speed designation	Designates the speed for various interpolation operations with a percentage (0.1% unit).	Ovrd 100
		Designate the speed for joint interpolation operation with a percentage (0.1% unit).	JOvrd 100
		Designates the speed for linear and circular interpolation with a numerical value (mm/s unit).	Spd 123.5
		Designates the acceleration/deceleration time as a percentage in respect to the predetermined maximum acceleration/deceleration. (1% unit)	Accel 50,80
		Automatically adjusts the acceleration/deceleration according to the parameter setting value.	Oadl ON
		Sets the hand and work conditions for automatic adjustment of the acceleration/deceleration.	Loadset 1,1
	Operation	Adds a process unconditionally to the operation.	Wth
		Adds a process conditionally to the operation.	Wthlf
		Designates smooth operation.	Cnt 1,100,200
		Performance of movement is upgraded corresponding to the application.	MvTune 4
		Designates the positioning completion conditions with a No. of pulses.	Fine 200
		Designates the positioning completion conditions with a distance in a straight line	Fine 1, P
		Turns the servo power ON/OFF for all axes.	Servo OFF
		Limits the operation of each axis so that the designated torque is not exceeded.	Torq 4,10
Position control	Designates the base conversion data.	Base P1	
	Designates the tool conversion data.	Tool P1	
Float control	The robot arm rigidity is lowered and softened. (XYZ coordinate system)	Cmp Pos ,&B00000011	
	The robot arm rigidity is lowered and softened. (JOINT coordinate system)	Cmp Jnt ,&B00000011	
	The robot arm rigidity is lowered and softened. (TOOL coordinate system)	Cmp Tool ,&B00000011	
	The robot arm rigidity is returned to the normal state.	Cmp Off	
	The robot arm rigidity is designated.	CmpG 1.0,1.0,1.0,1.0,1.0,1.0,1.0,1.0	

Type	Class	Function	Input format (example)	
Position and operation control	Pallet	Defines the pallet.	Def Plt 1,P1,P2,P3,P4,5,3,1	
		Operates the pallet grid point position.	Plt 1,M1	
	Singular point passage	Move to a specified position using linear interpolation passing through a singular point.	Mvs P1 Type 0,2	
	Branching	Branches unconditionally to the designated place.	Branches unconditionally to the designated place.	GoTo *LBL
			Branches according to the designated conditions.	If M1=1 Then GoTo *L100 Else GoTo *L200 EndIf
		Repeats until the designated end conditions are satisfied.	Repeats until the designated end conditions are satisfied.	For M1=1 To 10 Next M1
			Repeats while the designated conditions are satisfied.	While M1<10 WEnd
		Branches corresponding to the designated expression value.	On M1 GoTo *La1, *Lb2, *Lc3	
		Executes program block corresponding to the designated expression value.	Select Case 1 Break Case 2 Break End Select	
		Moves the program process to the next line.	Skip	
	Collision detection	Set to enable/disable the collision detection.	ColChk On/Off	
		Set the detection level of the collision detection.	ColLvl 100,80,,,,,	
	Subroutine	Executes the designated subroutine. (Within program)	GoSub *L200	
		Returns from the subroutine.	Return	
		Executes the designated program.	CallP "P10",M1,P1	
		Defines the program argument executed with the CALLP command.	FPm M10,P10	
		Executes the subroutine corresponding to the designated expression value.	On M1 GoSub*La1,*La2,*La3	
	Interrupt	Defines the interrupt conditions and process.	Def Act 1, M1=1 GoTo *L123	
		Enables/disables the interrupt.	Act 1=1	
		Defines the start line of the program to be executed when an interrupt is generated from the communication line.	On Com(1) GoSub *LABC	
		Enables the interrupt from the communication line.	Com(1) On	
		Disables the interrupt from the communication line.	Com(1) Off	
		Stops the interrupt from the communication line.	Com(1) Stop	
	Wait	Designates the wait time, and the output signal pulse output time. (0.01s unit)	Dly 0.5	
		Waits until the variable becomes the designated value.	Wait M_In(20)=1	
	Stop	Stops the program execution.	Hlt	
		Generates an error. During program execution, continue, stop or servo OFF can be designated.	Error 9000	
		Ends the program execution.	End	
	Hand	Hand open	Opens the designated hand.	HOpen 1
		Hand close	Closes the designated hand.	HClose 1
	Input/output	Assignment	Defines the input/output variables.	Def IO PORT1=Bit,99
		Input	Retrieves the general-purpose input signal.	M1=M_In (78)
		Output	Calls out the general-purpose output signal.	M_Out(23) =0
Parallel execution	Mechanism designation	Acquires the mechanism with the designated mechanism No.	GetM 1	
		Releases the mechanism with the designated mechanism No.	RelM 1	
	Selection	Selects the designated program for the designated slot.	XLoad 2,"P102"	
	Start/stop	Carries out parallel execution of the designated program.	XRun 3,"100",0	
		Stops parallel execution of the designated program.	XStp 3	
Returns the designated program's execution line to the head and enters the program selection enabled state.	XRst 3			

Type	Class	Function	Input format (example)
Others	Definition	Defines the integer type or real number type variable.	Def Inte KAISUU
		Defines the character string variable.	Def Char MESSAGE
		Defines the layout variable. (Up to 3-dimensional possible)	Dim PDATA(2,3)
		Defines the joint variable.	Def Jnt TAIHI
		Defines the position variable.	Def Pos TORU
		Defines the function.	Def FN TASU(A,B)=A+B
	Clear	Clears the general-purpose output signal, variables in program, variables between programs, etc.	Clr 1
	File	Opens a file.	Open "COM1:" AS #1
		Closes a file.	Close #1
		Inputs data from a file.	Input #1,M1
		Outputs data to a file.	Print #1,M1
	Comment	Describes a comment.	Rem "ABC"
	Label	Indicates the branching destination.	*SUB1

4.2 List of parameters

Show the main parameter in the  Table: List of parameters.

Table: List of parameters

Parameter	Details
Standard tool coordinates.	MEXTL Set the default value for the tool data. Unit: mm or deg.
Standard base coordinates	MEXBS Set the relation of the world coordinate system and robot coordinate system. Unit: mm or deg.
XYZ operation range	MEPAR Designate the overrun limit value for the world coordinate system.
JOINT operation range	MEJAR Set the overrun limit value for each joint axis.
Free plane limit	This is the overrun limit set with the free plane. Create a plane with the three coordinates x1, y1, z1 to x3, y3, z3, and set the outer side of the plane as the outside operation range (error). The following three types of parameters are used.
	SFC1P : SFC8P Eight types of free plane limits can be set in SFC1P to SFC8P. There are nine elements, set in the order of x1, y1, z1, x2, y2, z2, x3, y3, z3.
	SFC1ME : SFC8ME Designate which mechanism to use eight types of set free plane limits. The mechanism No. to use is set with 1 to 3.
	SFC1AT : SFC8AT Set the validity of the eight types of set free plane limits. (Valid 1/Valid 2/invalid = 1/-/1/0)
User-defined area	An area (cube) defined with two XYZ coordinate points can be designated and that area set as the outside operation range. Furthermore, a signal can be output when the axis enters that area. Up to 32 types of area can be designated.
	AREA1CS : AREA32CS Specify the coordinate system of the user definition area *. 0: Base coordinate system (conventional compatibility) 1: Robot coordinate system
	AREA1P1 : AREA32P1 Designated the 1st point of the area. There are eight elements, set in the order of x, y, z, a, b, c, L1, L2. (L1 and L2 are the additional axes.)
	AREA1P2 : AREA32P2 Designated the 2nd point of the area. There are eight elements, set in the order of x, y, z, a, b, c, L1, L2. (L1 and L2 are the additional axes.)
	AREA1ME : AREA32ME Designate which mechanism to use the 32 types of set area. The mechanism No. to use is set with 1 to 3.
	AREA1AT : AREA32AT Designate the area check type. (Invalid/zone/interference = 0/1/2) Zone: The dedicated output signal USRAREA turns ON. Interference: An error occurs..
	Automatic return setting
Buzzer ON/OFF	BZR Designate whether to the turn buzzer ON or OFF.
Jog setting	JOGJSP Designate the joint jog and step operation speed. (Set dimension H/L amount, max. override.)
	JOGPSP Designate the linear jog and step operation speed. (Set dimension H/L amount, max. override.)
Jog speed limit value	JOGSPMX Limit the operation speed during the teaching mode. Max. 250[mm/s]
Hand type	HANDTYPE Set the hand type of the single/double solenoid, and the signal No. (Single/double = S/D) Set the signal No. after the hand type. Example) D900
Stop input B contact designation	INB Change the dedicated input (stop) to either of normal open or normal close.
User-designated origin	USERORG Designate the user-designated origin position.
Program selection memory	SLOTON Select the program selected previously when initializing the slot. The non-selected state will be entered when not set.

Parameter	Details	
Communication setting	CBAU232	Set the baud rate.
	CLEN232	Set the character length.
	CPRTY232	Set the parity.
	CSTOP232	Set the stop bit.
	CTERM232	Set the end code.
Slot table	SLT1 : SLT32	Make settings (program name, operation type, order of priority, etc.) for each slot during slot initialization.
No. of multi-tasks	TASKMAX	Designate the No. of programs to be executed simultaneously. (Max. 32)
Multi CPU system setting	QMLTCPUN	At the multi CPU system, set the number of CPU units with which the standard base unit is equipped.
	QMLTCPUn	Sets the high-speed communication area of each CPU unit in the multi CPU system.
	QMLTCPUS	Sets the input offset of each CPU unit in the multi CPU system.
Select the function of singular point adjacent alarm	MESNGLSW	Designate the valid/invalid of the singular point adjacent alarm. (Invalid/Valid =0/1) When this parameter is set up "VALID", this warning sound is buzzing even if parameter: BZR (buzzer ON/OFF) is set up "OFF".
Display language	LNG	Sets the display language on the RT ToolBox3 (option).

5 Instruction Manual

5.1 Details of each instruction manual

The contents and purposes of the documents enclosed with this product are shown below.

Use these documents according to the application.

For special specifications, a separate instruction manual describing the special section may be enclosed.

Manual name	Description
Safety Manual	Explains the common precautions and safety measures to be taken for robot handling, system design and manufacture to ensure safety of the operators involved with the robot.
Standard Specifications	Explains the product's standard specifications, factory-set special specifications, option configuration and maintenance parts, etc. Precautions for safety and technology, when incorporating the robot, are also explained.
Robot Arm Setup & Maintenance	Explains the procedures required to operate the robot arm (unpacking, transportation, installation, confirmation of operation), and the maintenance and inspection procedures.
Controller setup, basic operation, and maintenance	Explains the procedures required to operate the controller (unpacking, transportation, installation, confirmation of operation), basic operation from creating the program to automatic operation, and the maintenance and inspection procedures.
Detailed explanations of functions and operations	Explains details on the functions and operations such as each function and operation, commands used in the program, connection with the external input/output device, and parameters, etc.
Troubleshooting	Explains the causes and remedies to be taken when an error occurs. Explanations are given for each error No.
Additional axis function	Explains the specifications, functions and operations of the additional axis control.
Tracking Function	Explains the control function and specifications of conveyor tracking.
GOT Direct Connection Extended Function	Explains the detailed description of data configuration of shared memory, monitoring, and operating procedures about the GOT (standalone type robot).
iQ Platform Supporting Extended Function	Explains the detailed description of data configuration of shared memory, monitoring, and operating procedures about the PLC (iQ Platform compatible type robot).
Safety communication function	Explains about the safety communication function which expands the robot safety functions by communicating safely with a safety programmable controller.
Ethernet Function	Explains the measures to perform communication with personal computers on Ethernet with the TCP/IP protocol.

6 Safety

6.1 Safety

Measures to be taken regarding safety of the industrial robot are specified in the "Labor Safety and Sanitation Rules". Always follow these rules when using the robot to ensure safety.

Self-diagnosis stop functions

This robot has the self-diagnosis stop functions shown in  Table: Self-diagnosis stop functions and the stop functions shown in  Table: List of stop functions for safe use.

Table: Self-diagnosis stop functions

No.	Function	Details	Remarks
1	Overload protection function *1	Activates when the total servo current time exceeds the specified value.	The drive circuit is shut off. The robot stops, and an alarm displays.
2	Overcurrent diagnosis function *1	Activates when an overcurrent flows to the motor circuit.	The drive circuit is shut off. The robot stops, and an alarm displays.
3	Encoder disconnection diagnosis function	Activates when the encoder cable is disconnected.	The drive circuit is shut off. The robot stops, and an alarm displays.
4	Deflection over diagnosis function	Activates when an error occurs between the command value and actual position, and the error exceeds the specified amount.	The drive circuit is shut off. The robot stops, and an alarm displays.
5	AC power voltage drop diagnosis function	Activates when the AC power voltage drops below the specified value.	The drive circuit is shut off. The robot stops, and an alarm displays.
6	CPU error detection function	Activates when an error occurs in the CPU.	The drive circuit is shut off. The robot stops, and an alarm displays.
7	Overrun prevention function	Software limit detection	This is the limit provided by the software to enable operation only in the operation range.
		Mechanical stopper	This is the mechanical stopper provided outside the software.

*1 There is no thermal memory function that conforms to EN 61800-5-1:2007/A1:2017

Table: List of stop functions

Stop function	Teaching pendant	External input	Details
Emergency stop	<input type="radio"/>	<input type="radio"/>	The servo power is shut off and the mechanical brakes activate to stop the robot by stopping operation in an emergency. To recover, reset the alarm, and turn the servo ON with the servo ON command.
Stop	<input type="radio"/>	<input type="radio"/>	The robot immediately decelerates to stop by stopping operation as usual. Note that the servo power is not shut off. Use this when using the collision evasion sensor, etc.

External input/output signals that can be used for safety protection measures

Table: External input/output signals that can be used for safety protection measures

Signal		Connection point	Parameter	Functions	Usage method
Input	External emergency stop *1	Connector CNUSR11	—	This servo power is shut off, and the robot stops immediately.	Externally installed emergency stop switch. Stopping at high-level error occurrence.
	Door switch input *1		—		The door switch of the safe protection fence.
	Stop	CR800-D: Parallel I/O unit or interface CR800-R/Q: Sequencer unit	STOP, STOP2	The program execution is stopped, and the robot stops. The servo power is not shut off.	The robot is stopped when a peripheral device fault occurs. The servo power is not shut off.
	Servo OFF		SRVOFF	The servo power can be shut off.	The robot is stopped when a peripheral device fault occurs. The servo power is also shut off.
	Automatic operation enable		AUTOENA	Disables automatic operation when inactive.	Door switch on safety protection fence.
Output	Emergency stop output	Connector CNUSR11	—	Outputs the input signal of external emergency stop or emergency stop switch of T/B turned on.	Display and warn the pilot lamp, the input signal of external emergency stop or the emergency stop switch of T/B turned on.
	In servo ON	CR800-D: Parallel I/O unit or interface CR800-R/Q: Sequencer unit	SRVON	The servo power ON/OFF state is output.	The servo power ON/OFF state is shown and alerted with the display lamps.
	Waiting		STOP, STOP2	Outputs that the robot is temporarily stopped.	The temporary stop state is shown and alerted with the display lamps.
	In alarm	Connector CNUSR11	ERRRESET	Outputs when an alarm occurs in the robot.	The alarm state is shown and alerted with the display lamps.

*1 The external emergency stop input and the door switch input have duplicate NC contacts for redundancy. Thus, if the emergency stop input circuit is opened when the robot is started up, the robot will not operate. Refer to  Page 278 Examples of safety measures for details.

And, refer to  Page 221 Automatic Operation/Jog Operation/Brake Release and Necessary Switch Settings for the function of the door switch input and the mode selector switch input.

Precautions for using robot

The safety measures for using the robot are specified in the "Labor Safety and Sanitation Rules". An outline of the rules is given below.

Robot installation

- Secure sufficient work space required to safely perform work such as teaching and maintenance related to the robot.
- Install the controller outside the robot's motion space. (If a safety fence is provided, install outside the fence.)
- Install the controller where the entire robot operation can be viewed.
- Install display lamps, etc., to indicate the robot's operation state.
- Securely fix the robot arm onto the fixing table with the designated bolts.

Prevention of contact with operator

- Install a safety fence or enclosure so that the operator cannot easily enter the robot's motion space.
- Install an interlock function that will stop the robot if the safety fence or enclosure door is opened.

Work procedures

- Create and observe work procedures for the robot teaching, operation, inspection and emergencies.
- Create hand signals to be followed when several operators are working together.
- Create displays such as "Teaching in Progress" and "Inspection in Progress" to be put up when an operator is in the robot's motion space so that other operators will not operate the operation panel (controller, control panel).

Training

- Train the operators about the operations, maintenance and safety required for the robot work.
- Only trained and registered operators must operate the robot. Participation in the "Special training for industrial robots" sponsored by the Labor Safety and Sanitation Committee, etc., is recommended for safety training.

Daily inspection and periodic inspection

- Always inspect the robot before starting daily operations and confirm that there are no abnormalities.
- Set the periodic inspection standards in view of the robot's ambient environment and operation frequency, and perform periodic inspections.
- Make records when periodic inspections and repairs have been done, and store the records for three or more years.

Safety measures for automatic operation

- (1) Install safety fences so that operators will not enter the operation area during operation and indicate that automatic operation is in progress with lamps, etc.
- (2) Create signals to be given when starting operation, assign a person to give the signal, and make sure that the operator follows the signals.

Safety measures for teaching

Observe the following measures when teaching, etc., in the robot's operation range.

- (1) Specify and follow items such as procedures related to teaching work, etc.
- (2) Take measures so that operation can be stopped immediately in case of trouble, and measures so that operation can be restarted.
- (3) Take measures with the robot start switch, etc., to indicate that teaching work is being done.
- (4) Always inspect that stop functions such as the emergency stop device before starting the work.
- (5) Immediately stop the work when trouble occurs, and correct the trouble.
- (6) Take measures so that the work supervisor can immediately stop the robot operation when trouble occurs.
- (7) The teaching operator must have completed special training regarding safety. (Training regarding industrial robots and work methods, etc.)
- (8) Create signals to be used when several operators are working together.

Safety measures for maintenance and inspections, etc.

Turn the power OFF and take measures to prevent operators other than the relevant operator from pressing the start switch when performing inspections, repairs, adjustments, cleaning or oiling.

If operation is required, take measures to prevent hazards caused by unintentional or mistaken operations.

- (1) Specify and follow items such as procedures related to maintenance work, etc.
- (2) Take measures so that operation can be stopped immediately in case of trouble, and measures so that operation can be restarted.
- (3) Take measures with the robot start switch, etc., to indicate that work is being done.
- (4) Take measures so that the work supervisor can immediately stop the robot operation when trouble occurs.
- (5) The operator must have completed special training regarding safety. (Training regarding industrial robots and work methods, etc.)
- (6) Create signals to be used when several operators are working together.

Examples of safety measures

The controller's dedicated I/O terminal connector has a duplicate emergency stop circuit.

The safety measure examples are shown in Fig.: Example of safety measures (wiring example 1) to Fig.: Example of safety measures (wiring example 4). Create a circuit as shown below for safety measures. In addition, the figure shows the normal state which is not in the emergency stop state.

[Note]

- In the emergency-stop related wiring by the customer, if the coil (is not the contact points) of the relay prepared by the customer is connected to the controller, please be sure to implement the measure against the noise by the customer in the coil section. And, please also take the lifetime of noise suppression parts into consideration.
- Electric specification of the emergency-stop-related output terminal: 24V DC or less, related current 100mA or less.
- In the customer's system, do not ground the + side of 24V power supply prepared by customer for connect to the controller. (related with emergency stop and parallel input/output) If it connects with the controller under the condition that the + side is grounded, it will lead to failure of controller.

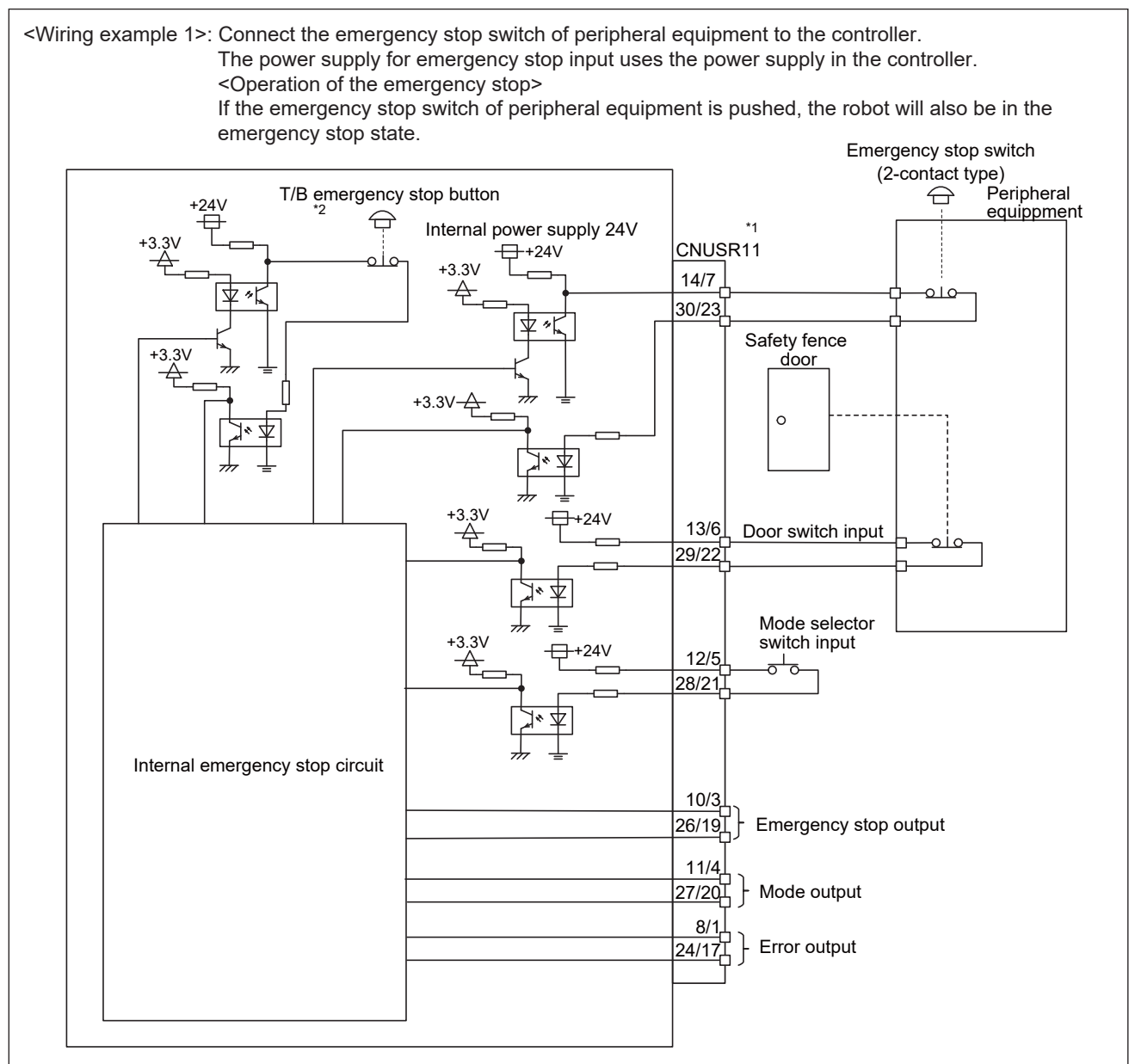

Fig.: Example of safety measures (wiring example 1)

*1 The CNUSR11 connector is a two-level terminal block, indicating that there are two circuits (channels). Two terminals (cable insertion holes) need to be used for one circuit.

*2 The T/B emergency stop button connected with the controller.

<Wiring example 2>: Connect the emergency stop switch, and door switch of peripheral equipment to the controller.
 The power supply for emergency stop input uses the power supply in the controller. Monitor the emergency stop state by the peripheral equipment side.
 <Operation of the emergency stop>
 If the emergency stop switch of peripheral equipment is pushed, the robot will also be in the emergency stop state.
 When the controller power is OFF, the peripheral devices are in the emergency stop state.

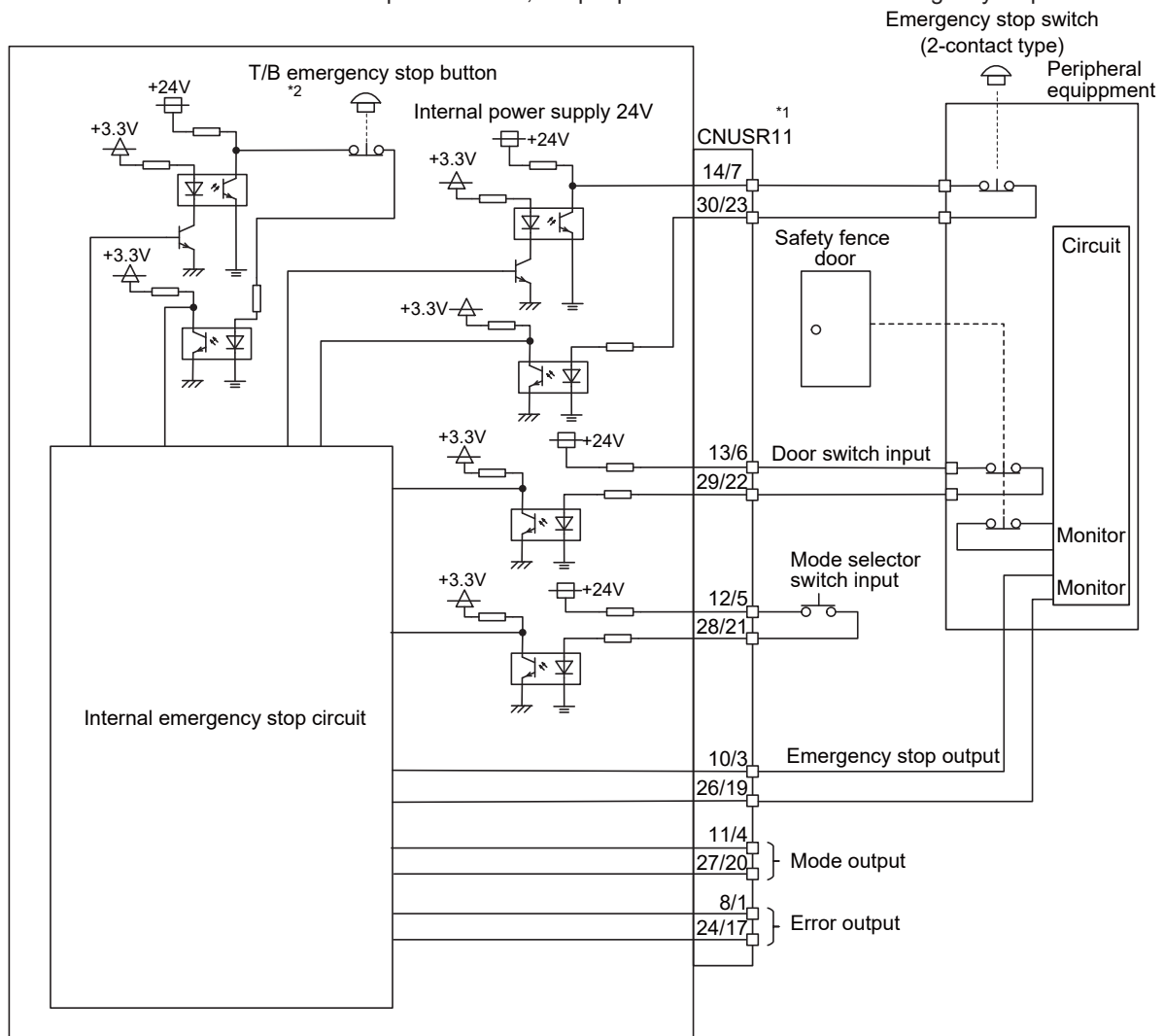

Fig.: Example of safety measures (wiring example 2)

*1 The CNUSR11 connector is a two-level terminal block, indicating that there are two circuits (channels). Two terminals (cable insertion holes) need to be used for one circuit.

*2 The T/B emergency stop button connected with the controller.

<Wiring example 3>: Connect the emergency stop switch of peripheral equipment, and the door switch to two controllers, and it interlocks. The power supply for emergency stop input uses the power supply in the controller.
 Monitor the emergency stop state by the peripheral equipment side.
 <Operation of the emergency stop>
 If the emergency stop switch of peripheral equipment is pushed, the robot will also be in the emergency stop state.
 When the controller power is OFF, the peripheral devices are in the emergency stop state.

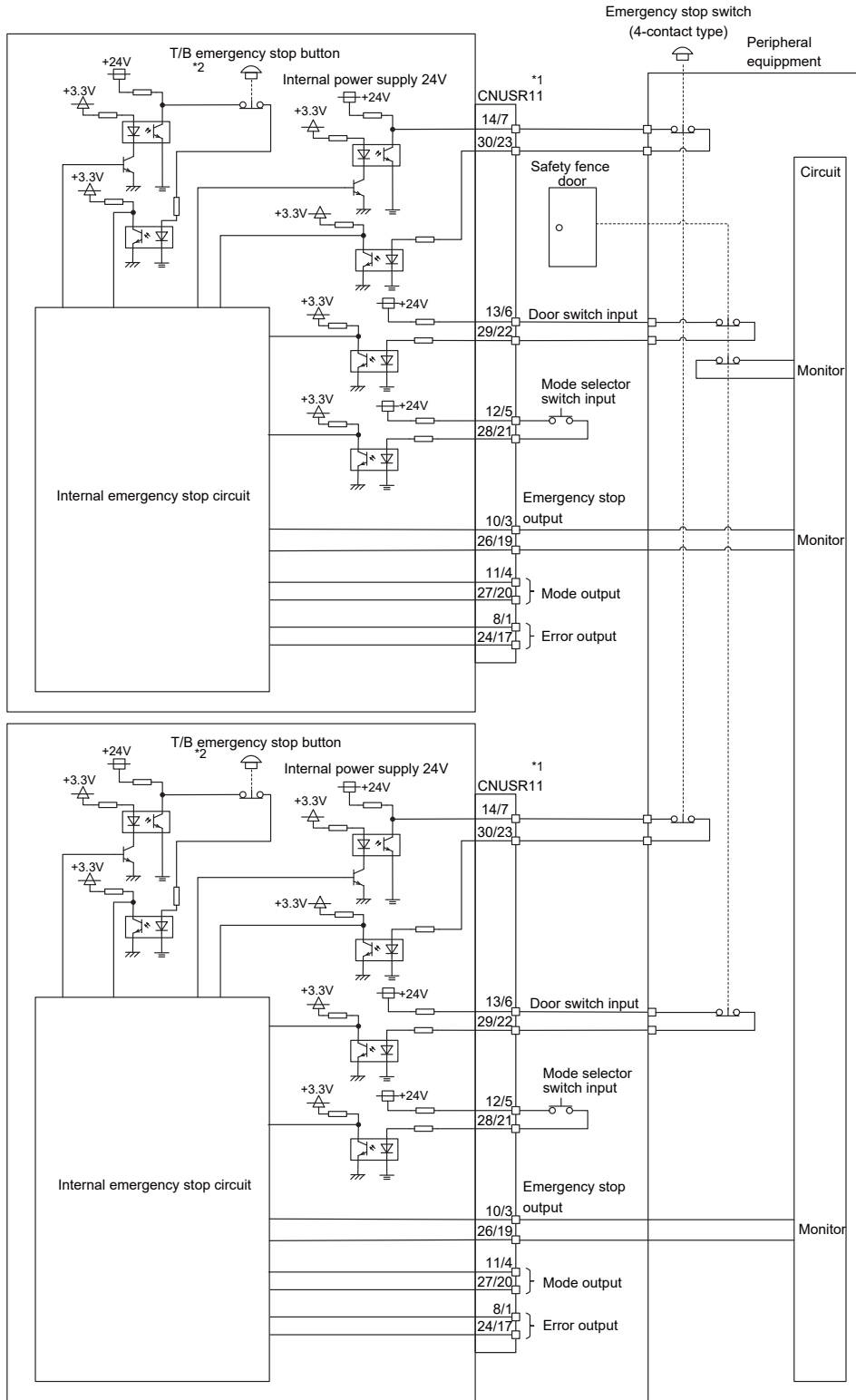
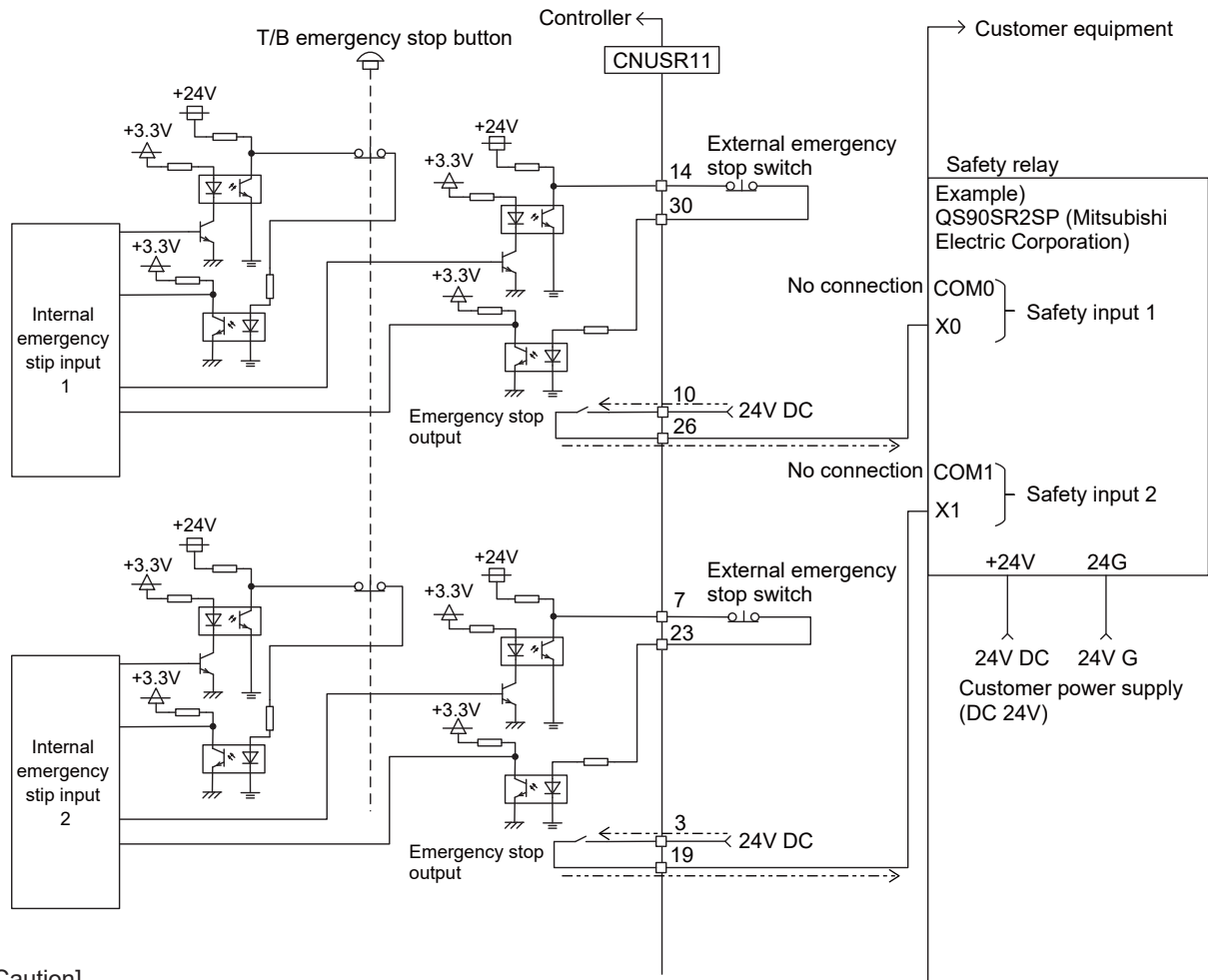

Fig.: Example of safety measures (wiring example 3)

- *1 The CNUSR11 connector is a two-level terminal block, indicating that there are two circuits (channels). Two terminals (cable insertion holes) need to be used for one circuit.
- *2 The T/B emergency stop button connected with the controller.

<Wiring example 4>: Connect the controller to the safety relay
 Use the controller's emergency stop button to input safety relay.



[Caution]

- 1) Setup a safety relay on the user equipment, and when using to input the emergency stop button on the controller, please only use a safety relay that functions when connecting the input to the one end of the 2 systems (i.e. QS90SR2SP (Manufacture: Mitsubishi Electric Corporation)).
- 2) When connecting emergency stop button output to an exterior safety relay, please take note of the polarity and make sure that the electrical current flows in the same direction as indicated by the dotted arrows in the two places in the diagram. If the polarity is setup incorrectly this function will not operate correctly. Please connect 3 and 10 terminal of CNUSR11 connector to 24V.

Fig.: Example of safety measures (wiring example 4)

External emergency stop connection [supplementary explanation]

(1) Use a 2-contact type switch for all switches.

(2) Install a limit switch on the safety fence's door. With a constantly open contact (normal open), wire to the door switch input terminal so that the switch turns ON (is conducted) when the door is closed, and turns OFF (is opened) when the door is open.

(3) Use a manual-return type of normal close which have two lines for the emergency stop button.

(4) Classify the faults into minor faults (faults that are easily restored and that do not have a great effect) and major faults (faults that cause the entire system to stop immediately, and that require care in restoration), and wire accordingly.

[Caution]

The emergency stop input (terminal block) on the user wiring in the controller can be used for safety measures as shown in figure above. Note that there are limits to the No. of switch contacts, capacity and cable length, so refer to the following and install.

- Switch contact

Prepare a 2-contact type. *1

- Switch contact capacity

Related current of 24 VDC or higher for a no-voltage contact. *1

- Cable length

The length of the wire between the switch and terminal block must be max. 15m or less. Please use the shield line, in case of the cable may receive the noise etc. by other equipment, such as servo amplifier. And, if it is necessary, please fix a ferrite core (recommended model name: E04SR301334, manufacturer: Seiwa Electric Mfg. Co., Ltd.) to the shielded cable.

The size of the wire that fits to use is shown below.

CNUSR11 connector: AWG24 to 16 (0.2 to 1.25mm²)

Electric specification of the emergency stop related output circuit is 100mA/24V or less. Don't connect the equipment except for this range.

CAUTION

Be sure to perform wiring correctly. If there are mistakes in the wiring, the robot may not stop when the emergency stop button is pressed and there will be a risk of damage or personal injury occurring.

After wiring, be sure to press each of the installed emergency stop switches and check whether the emergency stop circuit works properly.

CAUTION

Be sure to duplicate connection of the emergency stop, door switch and mode selector switch. If not duplicated, these functions may fail due to a broken relay used by customer, etc

*1 The minimum load electric current of the switch is more than 5mA/24V.

6.2 Working environment

Avoid installation in the following places as the equipment's life and operation will be affected by the ambient environment conditions. When using in the following conditions, the customer must pay special attention to the preventive measures.

Power supply

- Where the voltage fluctuation will exceed the input voltage range.
- Where a momentary power failure exceeding 20ms may occur.
- Where the power capacity cannot be sufficiently secured.

CAUTION

Please use the controller with an input power supply voltage fluctuation rate of 10% or less. In the case of 200 VAC input, for example, if the controller is used with 180 VAC during the day and 220 VAC during the night, turn the servo off once and then on again.

If this is not performed, an excessive regeneration or overvoltage error may occur.

Noise

- Where a surge voltage exceeding 2000V, 5kHz (equivalent to EN 61000-4-4) may be applied on the primary voltage.
Locations where a strong electric field or magnetic field exists, such as near large inverters, high output frequency oscillator, large contactors and welding machines.

[Recommendation]

A noise-cut transformer; a noise filter; reinforcement of ground lines and electromagnetic shields; isolation by keeping away from noise sources; reduction of noise level of emission.

This product has undergone EMC testing for products intended for use in industrial environments (tested to standards EN 61000-6-2 and EN 61000-6-4). This product is not intended to be connected to residential, commercial, or light-industrial power supplies.

Temperature and humidity

- Where the atmospheric temperature exceeds 40 degree , lower than 0 degree.
- Where the relative humidity exceeds 85%RH, lower than 45%RH, and where dew may condense.
- Where the robot will be subject to direct sunlight or near heat generating sources such as heaters.

Vibration

- Where excessive vibration or impact may be applied. (Use in an environment of 34m/s^2 or less during transportation and 5m/s^2 or less during operation.)

Installation environment

- Where strong electric fields or magnetic fields are generated.
- Where the installation surface is rough. (Avoid installing the robot on a bumpy or inclined floor.)
- Where there is heavy powder dust and oil mist present.

6.3 Precautions for handling

(1) This robot has brakes on J3 axes. The precision of the robot may drop, looseness may occur and the reduction gears may be damaged if the robot is moved with force with the brakes applied.

(2) Avoid moving the robot arm by hand. When unavoidable, gradually move the arm. If moved suddenly, the accuracy may drop due to an excessive backlash, or the backed up data may be destroyed.

(3) Note that depending on the posture, even when within the movement range, the shaft section could interfere with the base section. Take care to prevent interference during jog. *1

(4) The robot arm consists of precision parts such as bearing. Lubricants such as grease are also applied on the moving parts to keep the mechanical accuracy. In a cold start under low temperature or in the first start after being stored for one month or longer, lubricants may not be spread enough. Such condition may lower the positioning accuracy, cause servo and overload alarms, and early wearing of the moving parts. To avoid such situation, perform warm-up operation of the machine at a low speed (at about 20% of normal operation speed). Move the robot arm from the lower to the upper limit of the movable range with the 30 degree joint angle or more for about 10 minutes (RH-3FRHR series: for about 30 minutes). After that, speed up the operation gradually.

Please use the warm-up operation. (About the details of the warm-up operation, refer to  ICR800 Series Controller INSTRUCTION MANUAL Detailed explanations of functions and operations (BFP-A3478).)

(5) When the air hoses and cables are used inside the shaft (J3 axis), the grease for cable protection may ooze out or abrasion powders may be generated from the tip of the shaft while the robot is moving. However, movements and performance of the robot are not affected. Wipe off the grease or powders as required.

(6) The robot arm and controller must be grounded with 100Ω or less (class D grounding) to secure the noise resistance and to prevent electric shocks.

(7) The items described in these specifications are conditions for carrying out the periodic maintenance and inspections described in the instruction manual.

(8) When using the robot arm on a mobile axis or elevating table, the machine cables enclosed as standard configuration may break due to the fixed installation specifications. In this case, use the "machine cable (replacement) for flexed" options.

(9) If this robot interferes with the workpiece or peripheral devices during operation, the position may deviate, etc. Take care to prevent interference with the workpiece or peripheral devices during operation.

(10) Do not attach a tape or a label to the robot arm and the controller. If a tape or a label with strong adhesive power, such as a packaging tape, is attached to the coated surfaces of the robot arm and controller, the coated surface may be damaged when such tape or label is peeled off.

(11) If the robot is operated with a heavy load and at a high speed, the surface of the robot arm gets very hot. It would not result in burns, however, it may cause secondary accidents if touched carelessly.

(12) Do not shut down the input power supply to stop the robot. If the power supply is frequently shut down during a heavy load or high-speed operation, the speed reducer may be damaged, backlash may occur, and the program data may be destroyed.

(13) During the robot's automatic operation, a break is applied to the robot arm when the input power supply is shut down by a power failure, for instance. When a break is applied, the arm may deviate from the operation path predetermined by automatic operation and, as a result, it may interfere with the mechanical stopper depending on the operation at shutdown. In such a case, take an appropriate measure in advance to prevent any dangerous situation from occurring due to the interference between the arm and peripheral devices.

Example) Installing a UPS (uninterruptible power supply unit) to the primary power source in order to reduce interference.

(14) Do not conduct an insulated voltage test. If conducted by mistake, it may result in a breakdown.

(15) When the sequencer system becomes large too much, the robot's locus may deteriorate uncommonly. If this phenomenon occurs, inform to the dealer. And, when it turns out that the system is enlarged in advance, please inform our company.

(16) Fretting may occur on the axis which moving angle or moving distance move minutely, or not moves. Fretting is that the required oil film becomes hard to be formed if the moving angle is small, and wear occurs. The axis which not moved is moving slightly by vibration etc. To make no fretting recommends to move these axes about once every day the 30 degree or more, or the 20mm or more.

(17) The United Nations' Recommendations on the Transport of Dangerous Goods must be observed for transborder transportation of lithium batteries by air, sea, and land. The lithium batteries (MR-BAT6V1, Q6BAT) used in Mitsubishi industrial robots contain lithium and fall under the definition.

When the lithium batteries are shipped for storage, etc., they will be classified as Class 9: Miscellaneous dangerous substances and articles. Please contact your transportation company and must provide appropriate transport safety measures as the customer's consignor.

(18) If the air supply temperature (primary piping) used for the tool etc. is lower than ambient air temperature, the dew condensation may occur on the coupling or the hose surface.

(19) Collision detection function is valid condition for both of automatic and jog operation at shipping.

So, the robot stops immediately if the robot's tool or arm interferes with a peripheral device, minimizing damage. Therefore, please use in the valid condition.

(20) When fumigants that contain halogen materials such as fluorine, chlorine, bromine, and iodine are used for disinfecting and protecting wooden packaging from insects, they cause malfunction when entering our products. Please take necessary precautions to ensure that remaining materials from fumigant do not enter our products, or treat packaging with methods other than fumigation (heat method). Additionally, disinfect and protect wood from insects before packing products.

*1 Jog operation refers to operating the robot manually using the teaching pendant.

6.4 EMC installation guideline

Outlines

Industrial robots are one of the components of automation systems as well as main components. This section introduces methods and parts to ensure electromagnetic compatibility (EMC) in automation systems.

We test for EMC in the environment described in this manual, but the noise level varies depending on device types, layout, control panel structure, and wiring, etc. Please make final checks for EMC.

EMC

EMC can be broadly classified into two categories: EMI and EMS.

(1) Emission (EMI: Electromagnetic Interference)

The capacity not to generate the disturbance noise which has a bad influence outside.

(2) Immunity (EMS: Electromagnetic Susceptibility)

The capacity which does not malfunction for the disturbance noise from the outside.

Each contents are shown below.

Item	Name	Contents
Emission (EMI)	Radiative noise disturbance	The electromagnetic noise etc. which are emitted to environs.
	Electrical-conduction noise disturbance	The electromagnetism noise etc. which flow out of the power-supply line.
Immunity (EMS)	Electrostatic discharge immunity test	The noise from the electrified human body.
	Radiated, radio-frequency, electromagnetic field immunity test susceptibility test	The electromagnetism noise from the transceiver, the broadcasting station, etc.
	Electrical fast transient burst immunity test	The relay noise or the electromagnetism noise etc. which are caused in power-supply ON/OFF.
	Immunity to conducted disturbances induced radio-frequency fields	The electromagnetism noise etc. which flow in through the power source wire and the grounding wire.
	Power frequency magnetic field immunity test	The electromagnetism noise with a power supply frequency of 50/60 Hz etc.
	Voltage dips, short interruptions and voltage variations immunity test	The noise in the variation of the source voltage of the power dispatching, etc.
	Surge immunity test	The electromagnetism noise by the thunderbolt, etc.

EMC measures

There are mainly following items in the EMC measures.

- (1) Store into the sealed metal board.
- (2) Grounding all the conductor that have floated electrically (makes the impedance low).
- (3) Wiring so that the power source wire and signal wire are separated.
- (4) Use the shield cable for the cable which wired outside of the metal board.
- (5) Install the noise filter.

To suppress the noise emitted out of the board, be careful of the following item.

- (1) Ensure grounding of the equipment.
- (2) Use the shield cable.
- (3) Separate the metal board electrically. Narrows the distance/hole.

The strength of electromagnetic noise emitted to environment is changed a lot by the shielding efficiency of cable and the distance of metal board, so it should be careful.

Example of EMC measures

Industrial robots are designed for use with other devices. We test our industrial robots for conformity with EMC standards in the following system architecture. However, it does not mean that every system meets the requirements of EMC standards. Electromagnetic compatibility depends on the relationship between the industrial robot and devices in the system, wiring conditions, layout, or other factors. Therefore, check whether the entire machinery/system meets the requirements.

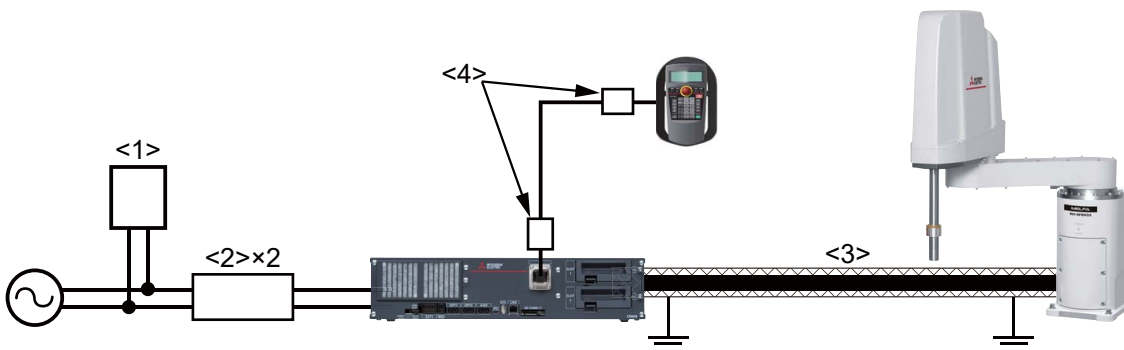

Fig.: Example of EMC measures

- 1) Attach the shield tube <3> to the machine cable and ground both ends of the tube.
- 2) Install the ferrite cores <4> on the cable of the teaching pendant.
- 3) Attach the noise filters <2> and surge protector <1> to the power cable.

Table: Parts for EMC measures

No.	Item	Model	Quantity	Manufacturer
1	Surge protector	LV275DI-Q4	1	OKAYA ELECTRIC INDUSTRIES CO., LTD.
2	Noise filter	RSMN-2016	2	TDK-Lambda Corporation
3	Shield tube	MTFX40	1	Zippertubing (Japan), Ltd.
4	Ferrite core	E04SR301334	2	SEIWA ELECTRIC MFG CO.Ltd

Parts for EMC measures

For details on the parts for EMC measures described on Page 287 Example of EMC measures contact your nearest Mitsubishi branch or dealer.

6.5 Standards

Information on product-specific standards can be found on the Mitsubishi Electric FA Global website.

<https://www.mitsubishielectric.com/fa/products/standard/SearchServlet.page?kisyu=/robot>

Appendix

Appendix 1 Inertia calculation method

An allowable moment of inertia in the mechanical interface at the tip of the robot arm is determined. If a load exceeding the allowable moment of inertia is put, on the tip of the arm, vibration during operation and an overload alarm may occur.

Therefore, consider the matching/appropriateness of the hand and load to be mounted on the tip of the arm for the robot specifications when you select a robot. The following describes the load inertia calculation method.

Calculate the total moment of inertia about the J4 axis.

$$I = I_{z1} + I_{z2} + W_1 L_1^2 + W_2 L_2^2$$

I: total moment of inertia about the J4 axis
I_z: load inertia
W: mass (kg)

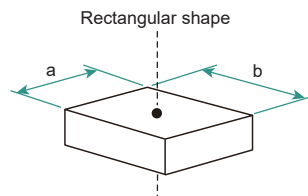
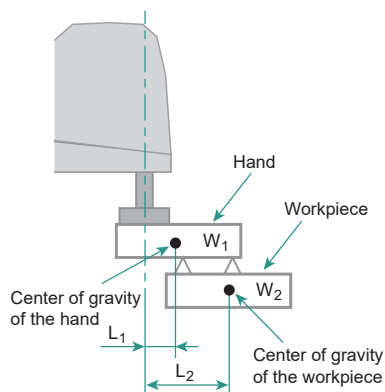

$$\text{Load inertia: } I_z = W \cdot \frac{a^2 + b^2}{12}$$

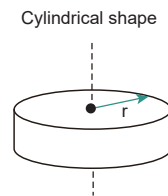

$$\text{Load inertia: } I_z = W \cdot \frac{r^2}{2}$$

[Calculation example]

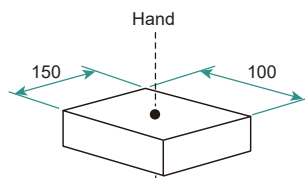
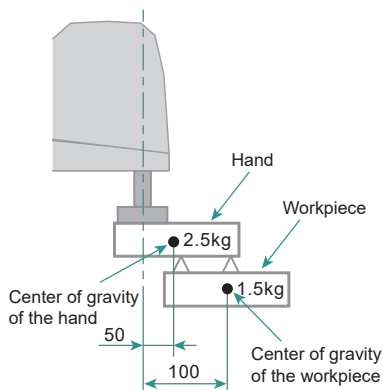

$$\text{Load inertia: } I_{z1} = 2.5 \times \frac{0.15^2 + 0.1^2}{12} = 0.0068 \text{ kg}\cdot\text{m}^2$$

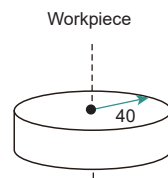

$$\text{Load inertia: } I_{z1} = 1.5 \times \frac{0.04^2}{2} = 0.0012 \text{ kg}\cdot\text{m}^2$$

Total moment of inertia about the J4 axis

$$I = 0.0068 + 0.0012 + 2.5 \times 0.05^2 + 1.5 \times 0.1^2 = 0.030 \text{ kg}\cdot\text{m}^2$$

The calculation result (0.030 kg·m²) is greater than the allowable inertia (rating) of 0.01 kg·m² for RH-6FRH.

However, if the center of gravity of the hand is aligned with the axis of rotation of J4 and the workpiece is held directly below the J4 axis, both L₁ and L₂ become zero and the total inertia around the J4 axis is calculated as follows.

$$I = 0.0068 + 0.0012 = 0.008 \text{ kg}\cdot\text{m}^2 < 0.01 \text{ kg}\cdot\text{m}^2$$



The result is smaller than the allowable inertia.

If the total moment of inertia exceeds the allowable inertia, consider changing the alignment or other conditions for the holding system.

Appendix 2 Classification of functions using external input/output signals

Before using the functions, note the following.

Table: Classification of functions using external input/output signals

Classification	Function	Description
Safety signal	Emergency stop input	Detects emergency stop inputs. The safety diagnosis function for the emergency stop input circuit makes the STO function meet the requirements of SIL 3, Category 4, PL e. At factory settings, the STO function meets the requirements of SIL 2, Category 3, PL d. To make the STO function meet the requirements of SIL 3, Category 4, PL e, change the parameter setting by referring to  Page 290 Safety diagnosis function (Test pulse diagnosis).
	Mode selector switch input	Switches the controller mode between MANUAL and AUTOMATIC.
	Door switch input	Receives the status of the switch installed on the door of the safety fence to detect the opening of the door.
Non-safety signal	Emergency stop output	Monitors whether the robot is in the emergency stop state.
	Mode output	Monitors whether the robot operates in MANUAL or AUTOMATIC mode.
	Robot error output	Monitors the error status of the robot.
	Additional axis synchronization output	Synchronizes the state of the additional axes (servo ON/OFF) with that of the robot arm. For details, refer to  Page 226 Additional axis synchronization output.



Appendix 3 Safety diagnosis function (Test pulse diagnosis)

This function enables diagnosis of external wiring by pulse signals output from the emergency stop ports (EXTEMG11, EXTEMG21). Changing parameter TPOEMG allows EXTEMG11 and EXTEMG21 to output off-pulses regularly. The width of output pulses is always approximately 20 ms. Checking regularly the test pulses inside the robot controller enables confirming the correct operation of the emergency stop lines.

When using this function, connect emergency stop switches by seeing  Fig.: How to wire emergency stop lines. Make sure to prevent test pulses of this function from causing faulty operation of peripheral devices.

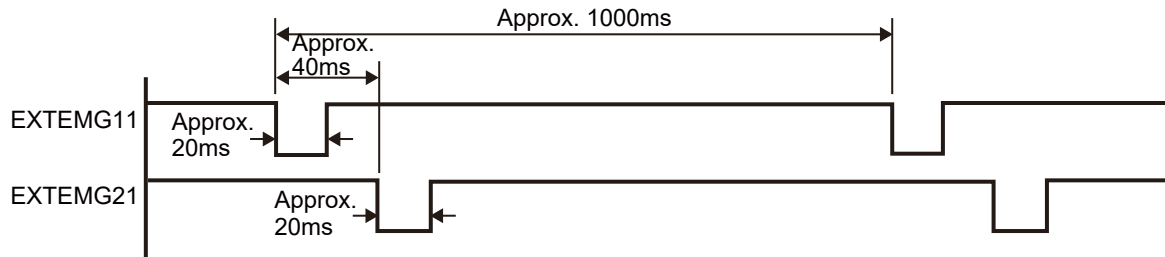

Fig.: Test pulse diagnosis

Table: Parameter details

Item	Description
Parameter name	TPOEMG
Function	This enables configuring the pulse output function for outputting test pulse signals from emergency stop ports (EXTEMG11, EXTEMG21).
What parameter settings means	0: Outputs no test pulses 1: Outputs test pulses
Default	0

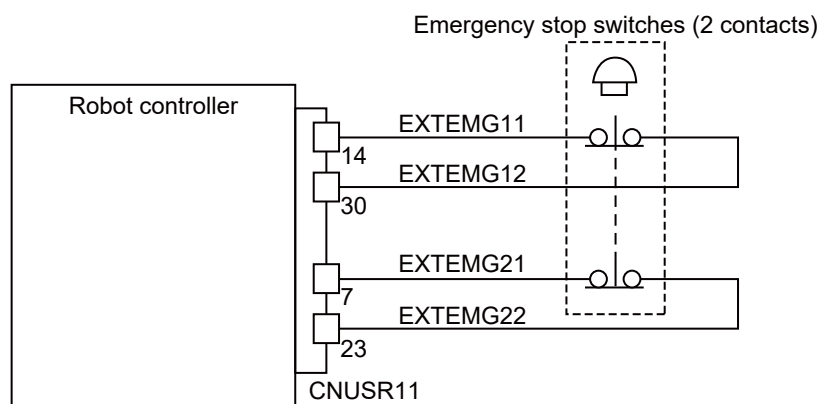

Fig.: How to wire emergency stop lines

Appendix 4 Safety block diagram

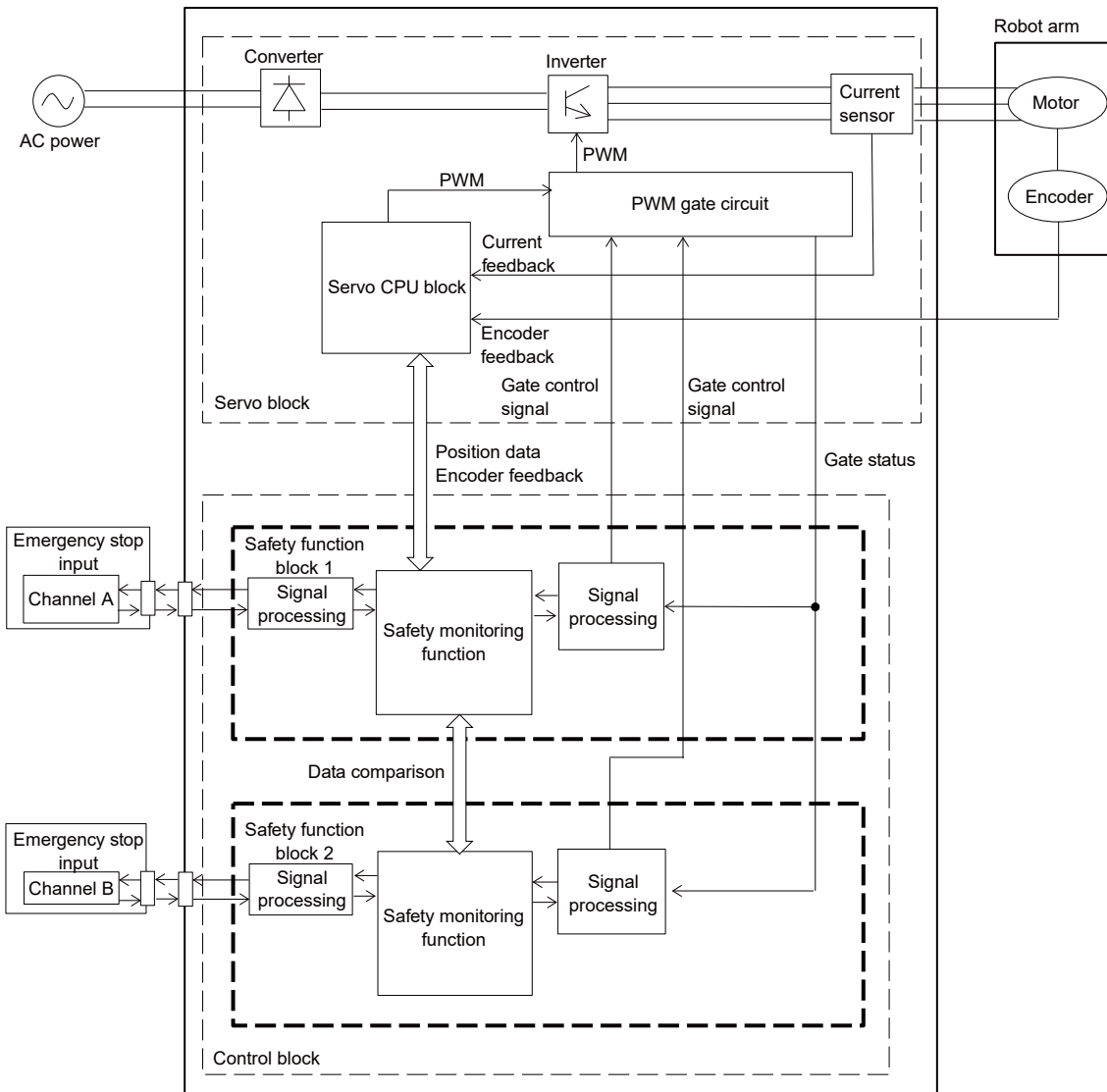



Fig.: Safety block diagram

A

Appendix 5 Origin position adjustment of J2 axis

When a calculated point is used for a robot's work point, the accuracy of J2 axis is important. This paragraph  Page 292 Origin position adjustment of J2 axis gives the details of an origin position adjustment by the configuration flag (RIGHT/LEFT).

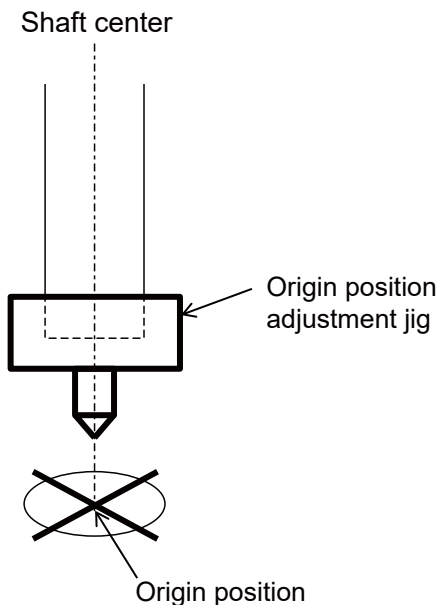

Fig.: Origin position adjustment

For the origin position adjustment, a reference point is an axis center of a shaft. When a center of the hand is offset from a center of the shaft, the hand must be removed before the origin position adjustment.

Origin position adjustment procedure

- 1) Designate any point as an origin position.
- 2) Match the center of the shaft with the origin position in a right hand coordinate system.
- 3) Perform teaching work to the joint variables JR.
- 4) Match the center of the shaft with the origin position in a left hand coordinate system.
- 5) Perform teaching work to the joint variables JL.
- 6) Execute the following commands in the order presented.

```
MDJNT_J2=(JR.J2+JL.J2)/2
JDJNT_Data=(0,0,0,0,0,0)
JDJNT_Data.J2=JDJNT_Data.J2-(MDJNT_J2)
PrmWrite 1,"DJNT",JDJNT_Data
```

- 7) Move J2 axis to 0 degrees, and check the robot position.

After the origin position adjustment, an adjusted value is stored in the parameter DJNT.

For another origin position adjustment with retaining an earlier adjusted value after the first adjustment is finished, change "JDJNT_Data=(0,0,0,0,0,0)" into "PrmRead 1,"DJNT",JDJNT_Data" before command execution.

As a repeat of command execution causes an accumulation of the adjusted values, clear the parameter DJNT back to 0 before another origin position adjustment.

Appendix 6 Specifications discussion material (RH-3FRH series)

Customer information

Company name		Name	
Address		Telephone	

Purchased model

Item	Type	Arm length	Stroke	Controller
General specification	RH-3FRH <input type="checkbox"/> 15-D	<input type="checkbox"/> 350 <input type="checkbox"/> 450 <input type="checkbox"/> 550	■ 150	CR800-03HD
	RH-3FRH <input type="checkbox"/> 15-R			CR800-03HR
	RH-3FRH <input type="checkbox"/> 15-Q			CR800-03HQ
Clean specification	RH-3FRH <input type="checkbox"/> 12C-D	<input type="checkbox"/> 350 <input type="checkbox"/> 450 <input type="checkbox"/> 550	■ 120	CR800-03HD
	RH-3FRH <input type="checkbox"/> 12C-R			CR800-03HR
	RH-3FRH <input type="checkbox"/> 12C-Q			CR800-03HQ

Shipping special specifications

Item	Standard specification	Special shipping specifications
Robot arm	Machine cable <input type="checkbox"/> 5m	<input type="checkbox"/> Not provided
Controller	Robot CPU unit connecting cable <input type="checkbox"/> 10m	<input type="checkbox"/> Not provided <input type="checkbox"/> 5m <input type="checkbox"/> 20m <input type="checkbox"/> 30m

Options (Installable after shipment)

Item	Type	Provision, and specifications when provided.	
Robot arm	Stopper for changing the operating range	1F-DH-01 <input type="checkbox"/> Not provided <input type="checkbox"/> Provided	
	Machine cable (replacement)	1F- <input type="checkbox"/> UCBL-41	Fixed type: <input type="checkbox"/> Not provide <input type="checkbox"/> 2m <input type="checkbox"/> 5m <input type="checkbox"/> 10m <input type="checkbox"/> 15m <input type="checkbox"/> 20m
		1F- <input type="checkbox"/> LUCBL-41	Flexed type: <input type="checkbox"/> Not provide <input type="checkbox"/> 10m <input type="checkbox"/> 15m <input type="checkbox"/> 20m
	Solenoid valve set	1F-VD0 <input type="checkbox"/> -01 1F-VD0 <input type="checkbox"/> E-01	<input type="checkbox"/> Not provide 1F-VD0 <input type="checkbox"/> -01 (Sink type): <input type="checkbox"/> 1set <input type="checkbox"/> 2set <input type="checkbox"/> 3set <input type="checkbox"/> 4set 1F-VD0 <input type="checkbox"/> E-01 (Source type): <input type="checkbox"/> 1set <input type="checkbox"/> 2set <input type="checkbox"/> 3set <input type="checkbox"/> 4set
	Hand input cable	1F-HC35C-01	<input type="checkbox"/> Not provided <input type="checkbox"/> Provided
	Hand output cable	1F-GR60S-01	<input type="checkbox"/> Not provided <input type="checkbox"/> Provided
	Hand curl tube	1E-ST0408C-300	<input type="checkbox"/> Not provided <input type="checkbox"/> Provided
External Wiring/Piping box	1F-UT-BOX	<input type="checkbox"/> Not provided <input type="checkbox"/> Provided	
Controller	Simple teaching pendant	R32TB- <input type="checkbox"/> <input type="checkbox"/>	<input type="checkbox"/> Not provided <input type="checkbox"/> 7m <input type="checkbox"/> 15m
	High-performance teaching pendant	R56TB- <input type="checkbox"/> <input type="checkbox"/>	<input type="checkbox"/> Not provided <input type="checkbox"/> 7m <input type="checkbox"/> 15m
	Parallel I/O interface	2D-TZ368/ 2D-TZ378	<input type="checkbox"/> Not provided 2D-TZ368(Sink type)/ <input type="checkbox"/> -1pc. <input type="checkbox"/> -2pc. 2D-TZ378(Source type)/ <input type="checkbox"/> -1pc. <input type="checkbox"/> -2pc.
	External I/O cable (For parallel I/O interface)	2D-CBL <input type="checkbox"/> <input type="checkbox"/> (2D-TZ368/TZ378)	<input type="checkbox"/> Not provided <input type="checkbox"/> 5m-()pc. <input type="checkbox"/> 15m-()pc.
	Parallel I/O unit	2A-RZ361/ 2A-RZ371	<input type="checkbox"/> Not provided <input type="checkbox"/> 2A-RZ361(Sink type)/() unit <input type="checkbox"/> 2A-RZ371(Source type)/() unit
	External I/O cable (For Parallel I/O unit)	2A-CBL <input type="checkbox"/> <input type="checkbox"/> (2A-RZ361/RZ371)	<input type="checkbox"/> Not provided <input type="checkbox"/> 5m-()pc. <input type="checkbox"/> 15m-()pc.
	CC-Link interface	2D-TZ576	<input type="checkbox"/> Not provided <input type="checkbox"/> Provided
	EtherNet/IP interface	2D-TZ535	<input type="checkbox"/> Not provided <input type="checkbox"/> Provided
	PROFINET interface	2D-TZ535-PN	<input type="checkbox"/> Not provided <input type="checkbox"/> Provided
	CC-Link IE Field interface	2F-DQ535	<input type="checkbox"/> Not provided <input type="checkbox"/> Provided
	EtherCAT interface	2F-DQ535-EC	<input type="checkbox"/> Not provided <input type="checkbox"/> Provided
	Function extension card	2F-DQ510	MELFA Smart Plus card pack (A-type): <input type="checkbox"/> Not provided <input type="checkbox"/> Provided
		2F-DQ520	MELFA Smart Plus card pack (AB-type): <input type="checkbox"/> Not provided <input type="checkbox"/> Provided
		2F-DQ511	MELFA Smart Plus card (A-type): <input type="checkbox"/> Not provided <input type="checkbox"/> Provided
		2F-DQ521	MELFA Smart Plus card (B-type): <input type="checkbox"/> Not provided <input type="checkbox"/> Provided
	SD memory card	2F-2GBSD	<input type="checkbox"/> Not provided <input type="checkbox"/> Provided
	Safety option	4F-SF002-01	<input type="checkbox"/> Not provided <input type="checkbox"/> Provided
	Controller protection box	CR800-MB	<input type="checkbox"/> Not provided <input type="checkbox"/> Provided
	RT ToolBox3	3F-14C-WINE	<input type="checkbox"/> Not provided <input type="checkbox"/> Windows 10/11 English DVD-ROM
	RT ToolBox3 mini	3F-15C-WINE	<input type="checkbox"/> Not provided <input type="checkbox"/> Windows 10/11 English DVD-ROM
RT ToolBox3 Pro	3F-16D-WINE	<input type="checkbox"/> Not provided <input type="checkbox"/> Windows 10/11 English DVD-ROM	
Instructions manual	5F-GG01-PE01	<input type="checkbox"/> Not provided <input type="checkbox"/> Provided () sets	
Function extension	Force sensor set	4F-FS002H-W200	<input type="checkbox"/> Not provided <input type="checkbox"/> Provided
		4F-FS002H-W1000	<input type="checkbox"/> Not provided <input type="checkbox"/> Provided
	MELFA-3D Vision 3.0	3F-53U-WINM	<input type="checkbox"/> Not provided <input type="checkbox"/> Provided

Maintenance parts (Consumable parts)

Maintenance parts	<input type="checkbox"/> Backup batteries MR-BAT6V1 () pcs. <input type="checkbox"/> Backup batteries Q6BAT*1 () pcs. <input type="checkbox"/> Grease () cans
-------------------	--

Robot selection check list

Work description	<input type="checkbox"/> Material handling <input type="checkbox"/> Assembly <input type="checkbox"/> Machining L/UL <input type="checkbox"/> Sealing <input type="checkbox"/> Testing and inspection <input type="checkbox"/> Other ()
Workpiece mass () g	Hand mass () g
Atmosphere <input type="checkbox"/> General environment <input type="checkbox"/> Clean () <input type="checkbox"/> Other ()	
Remarks	

*1 Only the CR800-Q controller is applicable.



Appendix 8 Specifications discussion material (RH-12FRH series)

Customer information

Company name		Name	
Address		Telephone	

Purchased model

Item	Type	Arm length	Stroke	Controller
General specification	RH-12FRH □□△△ -D	□ 550 □ 700 □ 850	□ 350 □ 450	<input type="checkbox"/> CR800-12HD
	RH-12FRH □□△△ -R			<input type="checkbox"/> CR800-12HR
	RH-12FRH □□△△ -Q			<input type="checkbox"/> CR800-12HQ
Clean specification	RH-12FRH □□△△ C-D	□ 550 □ 700 □ 850	□ 350 □ 450	<input type="checkbox"/> CR800-12HD
	RH-12FRH □□△△ C-R			<input type="checkbox"/> CR800-12HR
	RH-12FRH □□△△ C-Q			<input type="checkbox"/> CR800-12HQ
Oil mist specification	RH-12FRH □□△△ M-D	□ 550 □ 700 □ 850	□ 350 □ 450	<input type="checkbox"/> CR800-12HD
	RH-12FRH □□△△ M-R			<input type="checkbox"/> CR800-12HR
	RH-12FRH □□△△ M-Q			<input type="checkbox"/> CR800-12HQ

Shipping special specifications

Item	Standard specification	Special shipping specifications
Robot arm	Machine cable <input type="checkbox"/> 5m	<input type="checkbox"/> Not provided
Controller	Robot CPU unit connecting cable <input type="checkbox"/> 10m	<input type="checkbox"/> Not provided <input type="checkbox"/> 5m <input type="checkbox"/> 20m <input type="checkbox"/> 30m

Options (Installable after shipment)

Item	Type	Provision and specifications when provided.	
Robot arm	Stopper for changing the operating range	1F-DH-02 <input type="checkbox"/> Not provided <input type="checkbox"/> Provided	
	Machine cable (replacement)	1F-□□ UCBL-41 Fixed type: <input type="checkbox"/> Not provide <input type="checkbox"/> 2m <input type="checkbox"/> 5m <input type="checkbox"/> 10m <input type="checkbox"/> 15m <input type="checkbox"/> 20m 1F-□□ LUCBL-41 Flexed type: <input type="checkbox"/> Not provide <input type="checkbox"/> 10m <input type="checkbox"/> 15m <input type="checkbox"/> 20m	
	Solenoid valve set	1S-VD0 □ -01 <input type="checkbox"/> Not provide 1S-VD0 □ E-01 1S-VD0 □ -01 (Sink type): <input type="checkbox"/> 1set <input type="checkbox"/> 2set <input type="checkbox"/> 3set <input type="checkbox"/> 4set 1S-VD0 □ E-01 (Source type): <input type="checkbox"/> 1set <input type="checkbox"/> 2set <input type="checkbox"/> 3set <input type="checkbox"/> 4set	
	Hand input cable	1F-HC35C-02 <input type="checkbox"/> Not provided <input type="checkbox"/> Provided	
	Hand output cable	1F-GR60S-01 <input type="checkbox"/> Not provided <input type="checkbox"/> Provided	
	Hand curl tube	1N-ST0608C-01 <input type="checkbox"/> Not provided <input type="checkbox"/> Provided	
	External Wiring/Piping box	1F-UT-BOX-01 <input type="checkbox"/> Not provided <input type="checkbox"/> Provided	
	Internal Wiring/Piping for hand	1F-HS604S-01 <input type="checkbox"/> Not provided <input type="checkbox"/> Provided (For 350mm stroke) 1F-HS604S-02 <input type="checkbox"/> Not provided <input type="checkbox"/> Provided (For 450mm stroke)	
Controller	Simple teaching pendant	R32TB-□□ <input type="checkbox"/> Not provided <input type="checkbox"/> 7m <input type="checkbox"/> 15m	
	High-performance teaching pendant	R56TB-□□ <input type="checkbox"/> Not provided <input type="checkbox"/> 7m <input type="checkbox"/> 15m	
	Parallel I/O interface	2D-TZ368/ 2D-TZ378 <input type="checkbox"/> Not provided 2D-TZ368(Sink type)/□ -1pc. □ -2pc. 2D-TZ378(Source type)/□ -1pc. □ -2pc.	
	External I/O cable (For parallel I/O interface)	2D-CBL □□ <input type="checkbox"/> Not provided <input type="checkbox"/> 5m-()pc. <input type="checkbox"/> 15m-()pc. (2D-TZ368/TZ378)	
	Parallel I/O unit	2A-RZ361/ 2A-RZ371 <input type="checkbox"/> Not provided <input type="checkbox"/> 2A-RZ361(Sink type)/() unit <input type="checkbox"/> 2A-RZ371(Source type)/() unit	
	External I/O cable (For Parallel I/O unit)	2A-CBL □□ <input type="checkbox"/> Not provided <input type="checkbox"/> 5m-()pc. <input type="checkbox"/> 15m-()pc. (2A-RZ361/RZ371)	
	CC-Link interface	2D-TZ576 <input type="checkbox"/> Not provided <input type="checkbox"/> Provided	
	EtherNet/IP interface	2D-TZ535 <input type="checkbox"/> Not provided <input type="checkbox"/> Provided	
	PROFINET interface	2D-TZ535-PN <input type="checkbox"/> Not provided <input type="checkbox"/> Provided	
	CC-Link IE Field interface	2F-DQ535 <input type="checkbox"/> Not provided <input type="checkbox"/> Provided	
	EtherCAT interface	2F-DQ535-EC <input type="checkbox"/> Not provided <input type="checkbox"/> Provided	
	Function extension card	2F-DQ510	MELFA Smart Plus card pack (A-type): <input type="checkbox"/> Not provided <input type="checkbox"/> Provided
		2F-DQ520	MELFA Smart Plus card pack (AB-type): <input type="checkbox"/> Not provided <input type="checkbox"/> Provided
		2F-DQ511	MELFA Smart Plus card (A-type): <input type="checkbox"/> Not provided <input type="checkbox"/> Provided
		2F-DQ521	MELFA Smart Plus card (B-type): <input type="checkbox"/> Not provided <input type="checkbox"/> Provided
	SD memory card	2F-2GBSD <input type="checkbox"/> Not provided <input type="checkbox"/> Provided	
	Safety option	4F-SF002-01 <input type="checkbox"/> Not provided <input type="checkbox"/> Provided	
	Controller protection box	CR800-MB <input type="checkbox"/> Not provided <input type="checkbox"/> Provided	
	RT ToolBox3	3F-14C-WINE <input type="checkbox"/> Not provided <input type="checkbox"/> Windows 10/11 English DVD-ROM	
	RT ToolBox3 mini	3F-15C-WINE <input type="checkbox"/> Not provided <input type="checkbox"/> Windows 10/11 English DVD-ROM	
RT ToolBox3 Pro	3F-16D-WINE <input type="checkbox"/> Not provided <input type="checkbox"/> Windows 10/11 English DVD-ROM		
Instructions manual	5F-GG01-PE01 <input type="checkbox"/> Not provided <input type="checkbox"/> Provided () sets		
Function extension	Force sensor set	4F-FS002-W200 <input type="checkbox"/> Not provided <input type="checkbox"/> Provided 4F-FS002-W1000 <input type="checkbox"/> Not provided <input type="checkbox"/> Provided	
	MELFA-3D Vision 3.0	3F-53U-WINM <input type="checkbox"/> Not provided <input type="checkbox"/> Provided	

Maintenance parts (Consumable parts)

Maintenance parts	<input type="checkbox"/> Backup batteries MR-BAT6V1 () pcs. <input type="checkbox"/> Backup batteries Q6BAT*1 () pcs. <input type="checkbox"/> Grease () cans
-------------------	--

Robot selection check list

Work description	<input type="checkbox"/> Material handling <input type="checkbox"/> Assembly <input type="checkbox"/> Machining L/UL <input type="checkbox"/> Sealing <input type="checkbox"/> Testing and inspection <input type="checkbox"/> Other ()	
Workpiece mass () g	Hand mass () g	Atmosphere <input type="checkbox"/> General environment, <input type="checkbox"/> Clean <input type="checkbox"/> Oil mist: Confirm oil proof <input type="checkbox"/> request (Oil name:)/ <input type="checkbox"/> not request ^(Note1) <input type="checkbox"/> Dusts (Please take measures such as a jacket.) <input type="checkbox"/> Chemicals (Please consult), <input type="checkbox"/> Other ()
Remarks		

*1 Only the CR800-Q controller is applicable.

*2 Refer to  Page 77 Protection specifications about oil resistance.

Appendix 9 Specifications discussion material (RH-20FRH series)

Customer information

Company name		Name	
Address		Telephone	

Purchased model

Item	Type	Arm length	Stroke	Controller
General specification	RH-20FRH <input type="checkbox"/> <input type="checkbox"/> <input type="checkbox"/> <input type="checkbox"/> -D	<input type="checkbox"/> 850 <input type="checkbox"/> 1000	<input type="checkbox"/> 350 <input type="checkbox"/> 450	<input type="checkbox"/> CR800-20HD
	RH-20FRH <input type="checkbox"/> <input type="checkbox"/> <input type="checkbox"/> <input type="checkbox"/> -R			<input type="checkbox"/> CR800-20HR
	RH-20FRH <input type="checkbox"/> <input type="checkbox"/> <input type="checkbox"/> <input type="checkbox"/> -Q			<input type="checkbox"/> CR800-20HQ
Clean specification	RH-20FRH <input type="checkbox"/> <input type="checkbox"/> <input type="checkbox"/> <input type="checkbox"/> C-D	<input type="checkbox"/> 850 <input type="checkbox"/> 1000	<input type="checkbox"/> 350 <input type="checkbox"/> 450	<input type="checkbox"/> CR800-20HD
	RH-20FRH <input type="checkbox"/> <input type="checkbox"/> <input type="checkbox"/> <input type="checkbox"/> C-R			<input type="checkbox"/> CR800-20HR
	RH-20FRH <input type="checkbox"/> <input type="checkbox"/> <input type="checkbox"/> <input type="checkbox"/> C-Q			<input type="checkbox"/> CR800-20HQ
Oil mist specification	RH-20FRH <input type="checkbox"/> <input type="checkbox"/> <input type="checkbox"/> <input type="checkbox"/> M-D	<input type="checkbox"/> 850 <input type="checkbox"/> 1000	<input type="checkbox"/> 350 <input type="checkbox"/> 450	<input type="checkbox"/> CR800-20HD
	RH-20FRH <input type="checkbox"/> <input type="checkbox"/> <input type="checkbox"/> <input type="checkbox"/> M-R			<input type="checkbox"/> CR800-20HR
	RH-20FRH <input type="checkbox"/> <input type="checkbox"/> <input type="checkbox"/> <input type="checkbox"/> M-Q			<input type="checkbox"/> CR800-20HQ

Shipping special specifications

Item	Standard specification	Special shipping specifications
Robot arm	Machine cable <input type="checkbox"/> 5m	<input type="checkbox"/> Not provided
Controller	Robot CPU unit connecting cable <input type="checkbox"/> 10m	<input type="checkbox"/> Not provided <input type="checkbox"/> 5m <input type="checkbox"/> 20m <input type="checkbox"/> 30m

Options (Installable after shipment)

Item	Type	Provision, and specifications when provided.	
Robot arm	Stopper for changing the operating range	1F-DH-02 <input type="checkbox"/> Not provided <input type="checkbox"/> Provided	
	Machine cable (replacement)	1F- <input type="checkbox"/> <input type="checkbox"/> UCBL-41 Fixed type: <input type="checkbox"/> Not provide <input type="checkbox"/> 2m <input type="checkbox"/> 5m <input type="checkbox"/> 10m <input type="checkbox"/> 15m <input type="checkbox"/> 20m 1F- <input type="checkbox"/> <input type="checkbox"/> LUCBL-41 Flexed type: <input type="checkbox"/> Not provide <input type="checkbox"/> 10m <input type="checkbox"/> 15m <input type="checkbox"/> 20m	
	Solenoid valve set	1S-VD0 <input type="checkbox"/> -01 <input type="checkbox"/> Not provide 1S-VD0 <input type="checkbox"/> E-01 <input type="checkbox"/> 1S-VD0 <input type="checkbox"/> -01 (Sink type): <input type="checkbox"/> 1set <input type="checkbox"/> 2set <input type="checkbox"/> 3set <input type="checkbox"/> 4set <input type="checkbox"/> 1S-VD0 <input type="checkbox"/> E-01 (Source type): <input type="checkbox"/> 1set <input type="checkbox"/> 2set <input type="checkbox"/> 3set <input type="checkbox"/> 4set	
	Hand input cable	1F-HC35C-02 <input type="checkbox"/> Not provided <input type="checkbox"/> Provided	
	Hand output cable	1F-GR60S-01 <input type="checkbox"/> Not provided <input type="checkbox"/> Provided	
	Hand curl tube	1N-ST0608C-01 <input type="checkbox"/> Not provided <input type="checkbox"/> Provided	
	External Wiring/Piping box	1F-UT-BOX-01 <input type="checkbox"/> Not provided <input type="checkbox"/> Provided	
	Internal Wiring/Piping for hand	1F-HS604S-01 <input type="checkbox"/> Not provided <input type="checkbox"/> Provided (For 350mm stroke) 1F-HS604S-02 <input type="checkbox"/> Not provided <input type="checkbox"/> Provided (For 450mm stroke)	
Controller	Simple teaching pendant	R32TB- <input type="checkbox"/> <input type="checkbox"/> <input type="checkbox"/> Not provided <input type="checkbox"/> 7m <input type="checkbox"/> 15m	
	High-performance teaching pendant	R56TB- <input type="checkbox"/> <input type="checkbox"/> <input type="checkbox"/> Not provided <input type="checkbox"/> 7m <input type="checkbox"/> 15m	
	Parallel I/O interface	2D-TZ368/ 2D-TZ378 <input type="checkbox"/> Not provided 2D-TZ368(Sink type)/ <input type="checkbox"/> -1pc. <input type="checkbox"/> -2pc. 2D-TZ378(Source type)/ <input type="checkbox"/> -1pc. <input type="checkbox"/> -2pc.	
	External I/O cable (For parallel I/O interface)	2D-CBL <input type="checkbox"/> <input type="checkbox"/> <input type="checkbox"/> Not provided <input type="checkbox"/> 5m-()pc. <input type="checkbox"/> 15m-()pc.	
	Parallel I/O unit	2A-RZ361/ 2A-RZ371 <input type="checkbox"/> Not provided <input type="checkbox"/> 2A-RZ361(Sink type)/() unit <input type="checkbox"/> 2A-RZ371(Source type)/() unit	
	External I/O cable (For Parallel I/O unit)	2A-CBL <input type="checkbox"/> <input type="checkbox"/> <input type="checkbox"/> Not provided <input type="checkbox"/> 5m-()pc. <input type="checkbox"/> 15m-()pc.	
	CC-Link interface	2D-TZ576 <input type="checkbox"/> Not provided <input type="checkbox"/> Provided	
	EtherNet/IP interface	2D-TZ535 <input type="checkbox"/> Not provided <input type="checkbox"/> Provided	
	PROFINET interface	2D-TZ535-PN <input type="checkbox"/> Not provided <input type="checkbox"/> Provided	
	CC-Link IE Field interface	2F-DQ535 <input type="checkbox"/> Not provided <input type="checkbox"/> Provided	
	EtherCAT interface	2F-DQ535-EC <input type="checkbox"/> Not provided <input type="checkbox"/> Provided	
	Function extension card	2F-DQ510	MELFA Smart Plus card pack (A-type): <input type="checkbox"/> Not provided <input type="checkbox"/> Provided
		2F-DQ520	MELFA Smart Plus card pack (AB-type): <input type="checkbox"/> Not provided <input type="checkbox"/> Provided
		2F-DQ511	MELFA Smart Plus card (A-type): <input type="checkbox"/> Not provided <input type="checkbox"/> Provided
		2F-DQ521	MELFA Smart Plus card (B-type): <input type="checkbox"/> Not provided <input type="checkbox"/> Provided
	SD memory card	2F-2GBSD <input type="checkbox"/> Not provided <input type="checkbox"/> Provided	
	Safety option	4F-SF002-01 <input type="checkbox"/> Not provided <input type="checkbox"/> Provided	
Controller protection box	CR800-MB <input type="checkbox"/> Not provided <input type="checkbox"/> Provided		
RT ToolBox3	3F-14C-WINE <input type="checkbox"/> Not provided <input type="checkbox"/> Windows 10/11 English DVD-ROM		
RT ToolBox3 mini	3F-15C-WINE <input type="checkbox"/> Not provided <input type="checkbox"/> Windows 10/11 English DVD-ROM		
RT ToolBox3 Pro	3F-16D-WINE <input type="checkbox"/> Not provided <input type="checkbox"/> Windows 10/11 English DVD-ROM		
Instructions manual	5F-GG01-PE01 <input type="checkbox"/> Not provided <input type="checkbox"/> Provided () sets		
Function extension	Force sensor set	4F-FS002-W200 <input type="checkbox"/> Not provided <input type="checkbox"/> Provided 4F-FS002-W1000 <input type="checkbox"/> Not provided <input type="checkbox"/> Provided	
	MELFA-3D Vision 3.0	3F-53U-WINM <input type="checkbox"/> Not provided <input type="checkbox"/> Provided	

Maintenance parts (Consumable parts)

Maintenance parts	<input type="checkbox"/> Backup batteries MR-BAT6V1 () pcs. <input type="checkbox"/> Backup batteries Q6BAT*1 () pcs. <input type="checkbox"/> Grease () cans
-------------------	--

Robot selection check list

Work description	<input type="checkbox"/> Material handling <input type="checkbox"/> Assembly <input type="checkbox"/> Machining L/UL <input type="checkbox"/> Sealing <input type="checkbox"/> Testing and inspection <input type="checkbox"/> Other ()	
Workpiece mass () g	Hand mass () g	Atmosphere <input type="checkbox"/> General environment, <input type="checkbox"/> Clean <input type="checkbox"/> Oil mist: Confirm oil proof <input type="checkbox"/> request (Oil name:)/ <input type="checkbox"/> not request ^(Note1) <input type="checkbox"/> Dusts (Please take measures such as a jacket.), <input type="checkbox"/> Chemicals (Please consult), <input type="checkbox"/> Other ()
Remarks		

*1 Only the CR800-Q controller is applicable.

*2 Refer to  Page 77 Protection specifications about oil resistance.

Appendix 10 Specifications discussion material (RH-3FRHR series)

Customer information

Company name		Name	
Address		Telephone	

Purchased model

Item	Type	Arm length	Stroke	Controller
General specification	RH-3FRHR3515-D	■ 350	■ 150	<input type="checkbox"/> CR800-03HRD
	RH-3FRHR3515-R			<input type="checkbox"/> CR800-03HRR
	RH-3FRHR3515-Q			<input type="checkbox"/> CR800-03HRQ
Clean specification	RH-3FRHR3512C-D	■ 350	■ 120	<input type="checkbox"/> CR800-03HRD
	RH-3FRHR3512C-R			<input type="checkbox"/> CR800-03HRR
	RH-3FRHR3512C-Q			<input type="checkbox"/> CR800-03HRQ
Waterproof specification	RH-3FRHR3512W-D	■ 350	■ 120	<input type="checkbox"/> CR800-03HRD
	RH-3FRHR3512W-R			<input type="checkbox"/> CR800-03HRR
	RH-3FRHR3512W-Q			<input type="checkbox"/> CR800-03HRQ

Shipping special specifications

Item	Standard specification	Special shipping specifications
Robot arm	Machine cable <input type="checkbox"/> 5m	<input type="checkbox"/> Not provided
Controller	Robot CPU unit connecting cable <input type="checkbox"/> 10m	<input type="checkbox"/> Not provided <input type="checkbox"/> 5m <input type="checkbox"/> 20m <input type="checkbox"/> 30m

Options (Installable after shipment)

Item	Type	Provision, and specifications when provided.	
Robot arm	Stopper for changing the operating range	1S-DH-05J1 <input type="checkbox"/> Not provided <input type="checkbox"/> Provided 1S-DH-05J2 <input type="checkbox"/> Not provided <input type="checkbox"/> Provided	
	Machine cable (replacement)	1F- <input type="checkbox"/> UCBL-41 Fixed type: <input type="checkbox"/> Not provide <input type="checkbox"/> 2m <input type="checkbox"/> 5m <input type="checkbox"/> 10m <input type="checkbox"/> 15m <input type="checkbox"/> 20m	
		1F- <input type="checkbox"/> LUCBL-41 Flexed type: <input type="checkbox"/> Not provide <input type="checkbox"/> 10m <input type="checkbox"/> 15m <input type="checkbox"/> 20m	
	Solenoid valve set	1S-VD04-05 <input type="checkbox"/> Not provide <input type="checkbox"/> 1S-VD04-05 (Sink type)	
		1S-VD04E-05 <input type="checkbox"/> 1S-VD04E-05 (Source type)	
		1S-VD04W-05 <input type="checkbox"/> Not provide <input type="checkbox"/> 1S-VD04W-05 (Sink type)	
		1S-VD04WE-05 <input type="checkbox"/> 1S-VD04WE-05 (Source type)	
	Hand input cable	1S-HC00S-01 <input type="checkbox"/> Not provided <input type="checkbox"/> Provided	
	Hand output cable	1S-GR35S-02 <input type="checkbox"/> Not provided <input type="checkbox"/> Provided	
	Hand tube	1S-ST0304S <input type="checkbox"/> Not provided <input type="checkbox"/> Provided	
Controller	Simple teaching pendant	R32TB- <input type="checkbox"/> <input type="checkbox"/> <input type="checkbox"/> <input type="checkbox"/> <input type="checkbox"/> Not provided <input type="checkbox"/> 7m <input type="checkbox"/> 15m	
	High-performance teaching pendant	R56TB- <input type="checkbox"/> <input type="checkbox"/> <input type="checkbox"/> <input type="checkbox"/> <input type="checkbox"/> Not provided <input type="checkbox"/> 7m <input type="checkbox"/> 15m	
	Parallel I/O interface	2D-TZ368/ 2D-TZ378 <input type="checkbox"/> Not provided 2D-TZ368(Sink type)/ <input type="checkbox"/> -1pc. <input type="checkbox"/> -2pc. 2D-TZ378(Source type)/ <input type="checkbox"/> -1pc. <input type="checkbox"/> -2pc.	
	External I/O cable (For parallel I/O interface)	2D-CBL <input type="checkbox"/> <input type="checkbox"/> <input type="checkbox"/> <input type="checkbox"/> <input type="checkbox"/> Not provided <input type="checkbox"/> 5m-()pc. <input type="checkbox"/> 15m-()pc.	
	Parallel I/O unit	2A-RZ361/ 2A-RZ371 <input type="checkbox"/> Not provided <input type="checkbox"/> 2A-RZ361(Sink type)/() unit <input type="checkbox"/> 2A-RZ371(Source type)/() unit	
	External I/O cable (For Parallel I/O unit)	2A-CBL <input type="checkbox"/> <input type="checkbox"/> <input type="checkbox"/> <input type="checkbox"/> <input type="checkbox"/> Not provided <input type="checkbox"/> 5m-()pc. <input type="checkbox"/> 15m-()pc.	
	CC-Link interface	2D-TZ576 <input type="checkbox"/> Not provided <input type="checkbox"/> Provided	
	EtherNet/IP interface	2D-TZ535 <input type="checkbox"/> Not provided <input type="checkbox"/> Provided	
	PROFINET interface	2D-TZ535-PN <input type="checkbox"/> Not provided <input type="checkbox"/> Provided	
	CC-Link IE Field interface	2F-DQ535 <input type="checkbox"/> Not provided <input type="checkbox"/> Provided	
	EtherCAT interface	2F-DQ535-EC <input type="checkbox"/> Not provided <input type="checkbox"/> Provided	
	Function extension card	2F-DQ510	MELFA Smart Plus card pack (A-type): <input type="checkbox"/> Not provided <input type="checkbox"/> Provided
		2F-DQ520	MELFA Smart Plus card pack (AB-type): <input type="checkbox"/> Not provided <input type="checkbox"/> Provided
		2F-DQ511	MELFA Smart Plus card (A-type): <input type="checkbox"/> Not provided <input type="checkbox"/> Provided
		2F-DQ521	MELFA Smart Plus card (B-type): <input type="checkbox"/> Not provided <input type="checkbox"/> Provided
	SD memory card	2F-2GBSD <input type="checkbox"/> Not provided <input type="checkbox"/> Provided	
	Safety option	4F-SF002-01 <input type="checkbox"/> Not provided <input type="checkbox"/> Provided	
	Controller protection box	CR800-MB <input type="checkbox"/> Not provided <input type="checkbox"/> Provided	
	RT ToolBox3	3F-14C-WINE <input type="checkbox"/> Not provided <input type="checkbox"/> Windows 10/11 English DVD-ROM	
	RT ToolBox3 mini	3F-15C-WINE <input type="checkbox"/> Not provided <input type="checkbox"/> Windows 10/11 English DVD-ROM	
RT ToolBox3 Pro	3F-16D-WINE <input type="checkbox"/> Not provided <input type="checkbox"/> Windows 10/11 English DVD-ROM		
Instructions manual	5F-GG01-PE01 <input type="checkbox"/> Not provided <input type="checkbox"/> Provided () sets		
Function extension	Force sensor set	4F-FS002-W200 <input type="checkbox"/> Not provided <input type="checkbox"/> Provided 4F-FS002-W1000 <input type="checkbox"/> Not provided <input type="checkbox"/> Provided	
	MELFA-3D Vision 3.0	3F-53U-WINM <input type="checkbox"/> Not provided <input type="checkbox"/> Provided	

Maintenance parts (Consumable parts)

Maintenance parts	<input type="checkbox"/> Backup batteries MR-BAT6V1 () pcs. <input type="checkbox"/> Backup batteries Q6BAT*1 () pcs. <input type="checkbox"/> Grease () cans
-------------------	--

Robot selection check list

Work description	<input type="checkbox"/> Material handling <input type="checkbox"/> Assembly <input type="checkbox"/> Machining L/UL <input type="checkbox"/> Sealing <input type="checkbox"/> Testing and inspection <input type="checkbox"/> Other ()
Workpiece mass () g	Hand mass () g
Atmosphere <input type="checkbox"/> General environment, <input type="checkbox"/> Clean <input type="checkbox"/> Oil mist: Confirm oil proof <input type="checkbox"/> request (Oil name:)/ <input type="checkbox"/> not request ^{Note1)} <input type="checkbox"/> Dusts (Please take measures such as a jacket,) <input type="checkbox"/> Chemicals (Please consult,) <input type="checkbox"/> Other ()	
Remarks	

*1 Only the CR800-Q controller is applicable.

*2 Refer to Page 77 Protection specifications about oil resistance.

REVISIONS

*The manual number is given on the bottom left of the back cover.

Revision date	*Manual number	Description
April 2017	BFP-A3468	<ul style="list-style-type: none"> • First print
July 2017	BFP-A3468-A	<ul style="list-style-type: none"> • Additional camera head (4F-3DVS2-OPT1) and optional visual field expander (2F-3DVS2-OPT2) were deleted. (Error correction).
November 2017	BFP-A3468-B	<ul style="list-style-type: none"> • Description of countermeasures against unauthorized access was added. • Descriptions of CR800-R controller were supplemented. • Correction of errors. <p>GOT1000 was deleted. Description of optional SD memory card was moved to "3.9.2 CR800-D controller"</p>
March 2018	BFP-A3468-C	<ul style="list-style-type: none"> • Correction of figures. (Fig. 2-71, 72, 82, 83) • Descriptions of CR800-Q controller were added. • Notes were added to section 3.6. • Environmental conditions of electromagnetic noise was modified.
June 2018	BFP-A3468-D	<ul style="list-style-type: none"> • Revised the operation method of the brake release switch (Fig. 2-17, 18)
September 2018	BFP-A3468-E	<ul style="list-style-type: none"> • Function extension card (2F-DQ520, 2F-DQ521) were added
December 2018	BFP-A3468-F	<ul style="list-style-type: none"> • The attachments for the external wiring/piping box were corrected. • Added further explanation of the ACIN cable. • Added a network base card for EtherCAT (2F-DQ535-EC). • "3.8 Magnet contactor control connector output (AXMC) for addition axes" was modified.
April 2019	BFP-A3468-G	<ul style="list-style-type: none"> • Correction of errors. <p>Communication interface between robot controllers of CR800-D controller was deleted. Description of connectors (EXT1, OPT1, OPT2) was modified. Correction of figures. (Fig. 2-43, 45, 47, 49, 51, 53, 55, 57, 59, 61, 65 to 68)</p>
July 2019	BFP-A3468-H	<ul style="list-style-type: none"> • Added the procedure for enabling the safety diagnosis function (STO function).
January 2020	BFP-A3468-J	<ul style="list-style-type: none"> • Adopted the DVD-ROM format for RT ToolBox3/RT ToolBox3 mini. • Added a figure to "2.1.2 The counter-force applied to the installation surface". • Added information on the space required for installing and removing the cover. (Fig. 2-19, 21, 23, 25, 27, 29, 31, 33, 35, 37, 39, 41) • Correction of errors. <p>Corrected the specifications of valves for solenoid valve sets. (Table 2-25) Corrected the name of a contact for NETcable-1 and the number of connectors/contacts. (Fig. 3-33) • Corrected the name of a signal. (Table 7-2)</p>
October 2020	BFP-A3468-K	<ul style="list-style-type: none"> • Amended the precautions regarding the prevention of unauthorized access. • Added "Appendix 5: Origin position adjustment of J2 axis". • Added an example of a protective circuit. (Fig. 3-10) • Removed Windows XP and Windows Vista from the supported operating systems for RT ToolBox3, RT ToolBox3 mini, and RT ToolBox3 Pro. • Added information to the specifications of the earth leakage breaker. • Added precautions for vertical installation of the robot controller. • Corrected other mistakes and changed some sections.
January 2021	BFP-A3468-M	<ul style="list-style-type: none"> • Added "6.4 EMC installation guideline".
January 2021	BFP-A3468-N	<ul style="list-style-type: none"> • Updated contents for the optional product "MELFA-3D Vision 3.0 (3F-53U-WINM)"
April 2021	BFP-A3468-P	<ul style="list-style-type: none"> • Added the Safety Communication Function Instruction Manual. • Elaborated on explanations on the STO function.
September 2021	BFP-A3468-R	<ul style="list-style-type: none"> • Corrected the explanation of the parameter "SRVON". • Added illustrations showing the installation position of ferrite cores. (Fig. 3-11) • Revised "(1) Parallel I/O interface". • Revised "(3) Parallel I/O unit". • Corrected the explanation of noise in "6.2 Working environment". • Corrected other mistakes and changed some sections
January 2022	BFP-A3468-S	<ul style="list-style-type: none"> • Revised "6.4 EMC installation guideline". • Corrected other mistakes and changed some sections.
June 2022	BFP-A3468-T	<ul style="list-style-type: none"> • Corrected the model name of the EtherCAT module manufactured by HMS
November 2022	BFP-A3468-U	<ul style="list-style-type: none"> • Changed the plug of the external I/O cable for the parallel I/O interface. • Corrected other mistakes and changed some sections
April 2023	BFP-A3468-V	<ul style="list-style-type: none"> • The HMS module model was corrected. • Added tables about controller safety performance. (Tables 3-2, 5, and 8) • Corrected other mistakes and changed some sections

Revision date	*Manual number	Description
June 2023	BFP-A3468-W	<ul style="list-style-type: none"> Added information on the fault loop impedance to "3.1.2 (2) Operating supply". Added descriptions to "6.1.1 Table 6-1: Self-diagnosis stop functions" regarding that the thermal memory function is not supported for the overload protection function and overcurrent diagnosis function
September 2023	BFP-A3468-X	<ul style="list-style-type: none"> Added information on PoE device connection to "2.5.5 Ethernet cable (For RH-3FRH/6FRH/12FRH/20FRH series)". Corrected "2.5.9 Electrical specifications of hand input/output". Changed some sections.
April 2024	BFP-A3468-Y	<ul style="list-style-type: none"> Amended images in "1.3.2 Robot controller". Amended images in "3.6.3 Door switch function". Amended images in "3.9.1 CR800-D/R/Q controller common" Amended images in "6.4.4 Example of EMC measures". Updated branch information. Corrected other mistakes and changed some sections.
September 2024	BFP-A3468-Z	<ul style="list-style-type: none"> Added product without machine cable. Added "1.2.3 Inclusion of machine cable". Added "6.5 Standards". Removed Windows 7, Windows 8, and Windows 8.1 from the supported operating systems for RT ToolBox3, RT ToolBox3 mini, and RT ToolBox3 Pro. Added Windows 11 to the supported operating systems for RT ToolBox3, RT ToolBox3 mini, and RT ToolBox3 Pro. Changed other sections. Changed some sections in conjunction with the e-Manual.

This manual confers no industrial property rights or any rights of any other kind, nor does it confer any patent licenses. Mitsubishi Electric Corporation cannot be held responsible for any problems involving industrial property rights which may occur as a result of using the contents noted in this manual.

© 2017 MITSUBISHI ELECTRIC CORPORATION

TRADEMARKS

No part of this manual may be reproduced by any means or in any form, without prior consent from Mitsubishi.

The contents of this manual are subject to change without notice.

The specifications values are based on Mitsubishi standard testing methods.

The information contained in this document has been written to be accurate as much as possible.

Please interpret that items not described in this document "cannot be performed" or "error may occur".

Please contact your nearest dealer if you find any doubtful, wrong or skipped point.

This is the original document.

Microsoft, Windows, Windows 10, and Windows 11 are registered trademarks of Microsoft Corporation in the United States and other countries.

The official name of Windows[®] is Microsoft[®]Windows[®]Operating System.

Windows[®] 10 and Windows[®] 11 are trade names of Microsoft Corporation in the United States.

Ethernet is registered trademarks or trademarks of Xerox Corporation in the United States.

All other company names and production names in this document are the trademarks or registered trademarks of their respective owners.

Referenced Standard (Requirement of Chinese standardized law): This Product is designed and manufactured accordance with GB 11291.1.

Illustrations in this Instruction Manual may differ from the actual products.

BFP-A3468-Z(2409)MEE

mitsubishi electric corporation

HEAD OFFICE: TOKYO BLDG., 2-7-3, MARUNOUCHI, CHIYODA-KU, TOKYO 100-8310, JAPAN
NAGOYA WORKS: 1-14, YADA-MINAMI 5-CHOME, HIGASHI-KU, NAGOYA 461-8670, JAPAN

Specifications subject to change without notice.