

SMART

Sensor Monitored Assembly Repair Tool

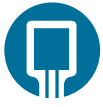

ForceSense



SmartSense



Product description

General function

SMART is a force monitored manual clamp closing tool. It is used to close the common adjustable ear clamps with different required closing forces 1800 N, 2400 N and 3800 N.

Compatibilities

Common adjustable ear clamps

Intended use

Closure of ear clamps until the pre-set closing forces are reached and indicated through light and vibration.

Certifications

CE, REACH, RoHS certified, Directive 2011/65/EC

Packaging

Protective plastic kit

Specials

Battery SAFT LS14500 3.6 V AA

General data

Model and type

SMART

Article no

14100637 (incl. packaging)

GTIN / EAN

0725765155634

Product attributes

Overview functional parts

1 Handles | 2 Handle grip | 3 Shrink hose | 4 Pincer jaws
 5 Clamping zone | 6 Force indicator (LED) | 7 Force stage indicator (LED) | 8 Switch button | 9 Protective cap
 10 Battery | 11 Battery container cover | 12 Carrier
 13 QR code “manuals”

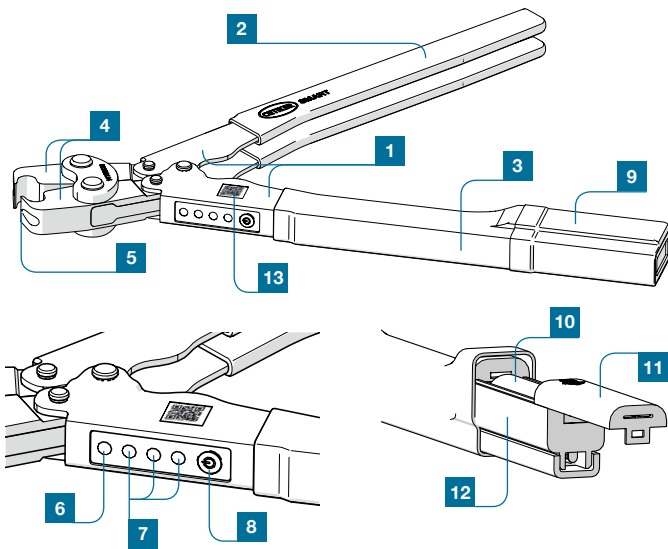

Dimensions

Length	299 mm
Width	58 mm
Height	26 mm
Weight	696 g
Jaw width	12.7 mm
Maximum jaw gap	12.3 mm
Minimum jaw gap	0.25 mm
Reference jaw force	1800 N, 2400 N, 3800 N

Materials

Handle: 1050 (ASTM). Plastisol, polyolefin.

Jaws: 42CrMo4 (EN 1.7225)

Functional critical attributes

Interfaces

- Closing clamps manually in the CVJ application in a garage environment
- Other applications

Performance parameters

Material	Width (w)	kN	Oetiker ref.
Stainless steel	9 mm	3.8	259
Stainless steel	7 mm	2.4	159, 167, 163(*)
Non-stainless steel	7 or 9 mm	1.8	109



(*) For 163 clamps, 1.8kN for diameter below 50 mm, 2.4 kN for diameter above 50 mm

Product damaging parameters

The tool has passed the drop resistant test, but it shall be handled with care and avoid high impact, e.g. used as a hammer.

The tool passed the water splash tests. This does not mean the tool can be dipped in water.

Operating parameters

- Temperature -5 to +50 °C
- Designed to work in moisture environment

Product impacting environment parameters

EMC test pass

Life time

The legal warranty applies.

Maintenance attributes

Maintenance cycle

If the force indicator is flashing, the battery must be changed.

Maintenance responsibility

Handle with care. Maintenance not provided.

Spare parts

Battery SAFT LS14500 3.6 V AA

Health safety critical attributes

Safety features

See instruction manual for detailed safety instructions.

