

fCAL 1

Calibration Measurement Unit



Product description

General function

The Oetiker fCAL 1 is a high-precision force measurement system to verify performance of all Oetiker clamp power tools. The handheld device pairs with interchangeable sensors and jaws, adapting easily to different tool geometries and configurations.

Compatibilities

All Oetiker clamp power tools

Intended use

Designed for quality control, maintenance, production, and service departments to measure the closing force of Oetiker power tools.

Certifications*

CE marked

EMC compliant

(*See supplement page for additional information)

Packaging

Comes in a protective case with foam insert that fits one measurement device, up to three sensors, and accessories.

Dimensions fCAL 1 Transport Case:

Length: 440 mm | Width: 360 mm | Height: 120 mm

Weight: 2263 g

Batteries

NiMH rechargeable batteries (4x AA 1.2 V 2500 mAh)

General data

Article numbers*

- 32100060 fCAL 1 Measuring Device
- 32100028 6 kN Closing Force Sensor
- 32100078 10 kN Closing Force Sensor
- 32100095 fCAL 1 Carrying Case
- 32100089 fCAL 1 Accessory Bundle

* See supplement page for additional information

Product attributes

Overview functional parts

fCAL 1 Calibration Measurement Unit

fCAL 1 Calibration Measuring Unit
fCAL 1 Measuring Device
fCAL 1 Closing Force Sensor
fCAL 1 Closing Force Jaws

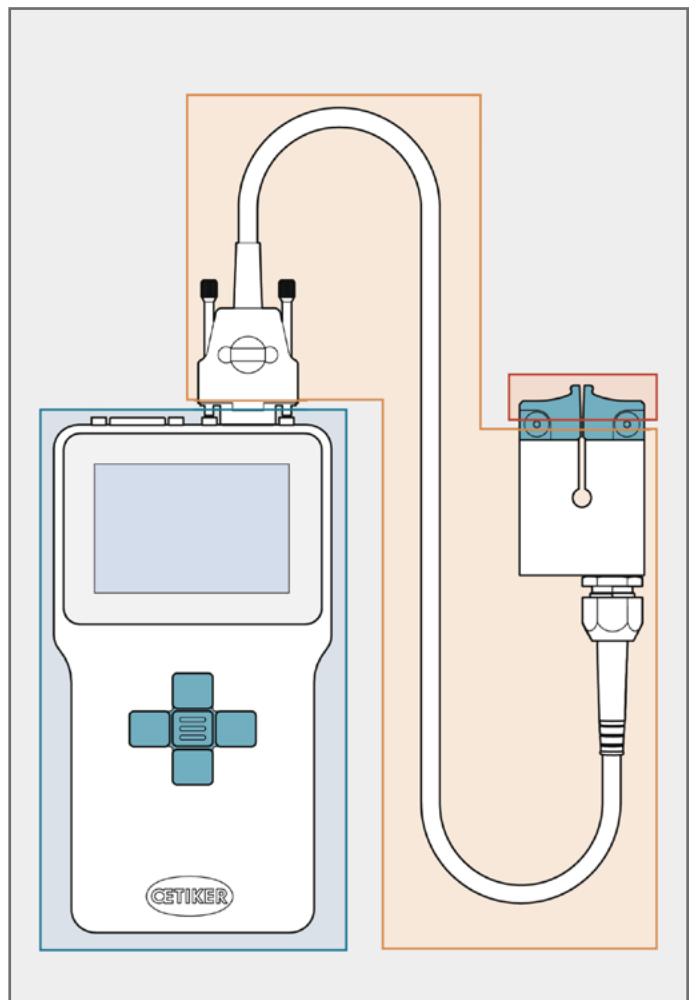

fCAL 1 Measuring Device



1 Display | 2 Control panel | 3 Charging port (USB-C) | 4 X5 interface fCAL 1 Closing Force Sensor (CFS) | 5 X3 interface PC / EPC 01 (RS232) | 6 2x M3 mounting threads for wall mounting | 7 Battery compartment

Dimensions

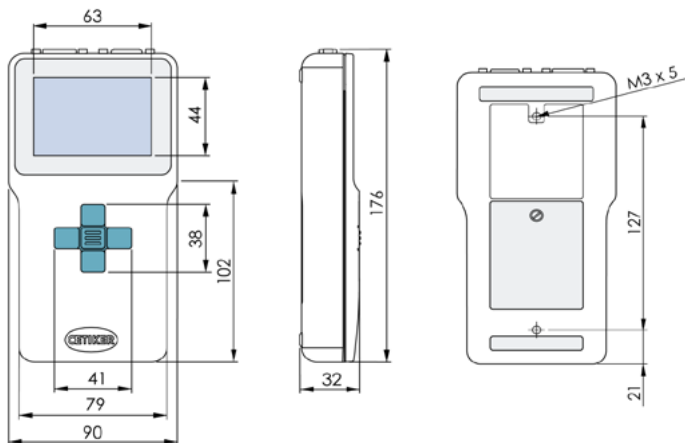

Length	176 mm
Width	90 mm
Height	32 mm
Weight	280 g (without batteries)
Batteries	4x 20g each (80 grams total)

Materials

- Impact-resistant polycarbonate (PC) plastic
- Acrylonitrile butadiene styrene (ABS) plastic
- Tempered glass
- Silicone

fCAL 1 Closing Force Sensor and Jaws

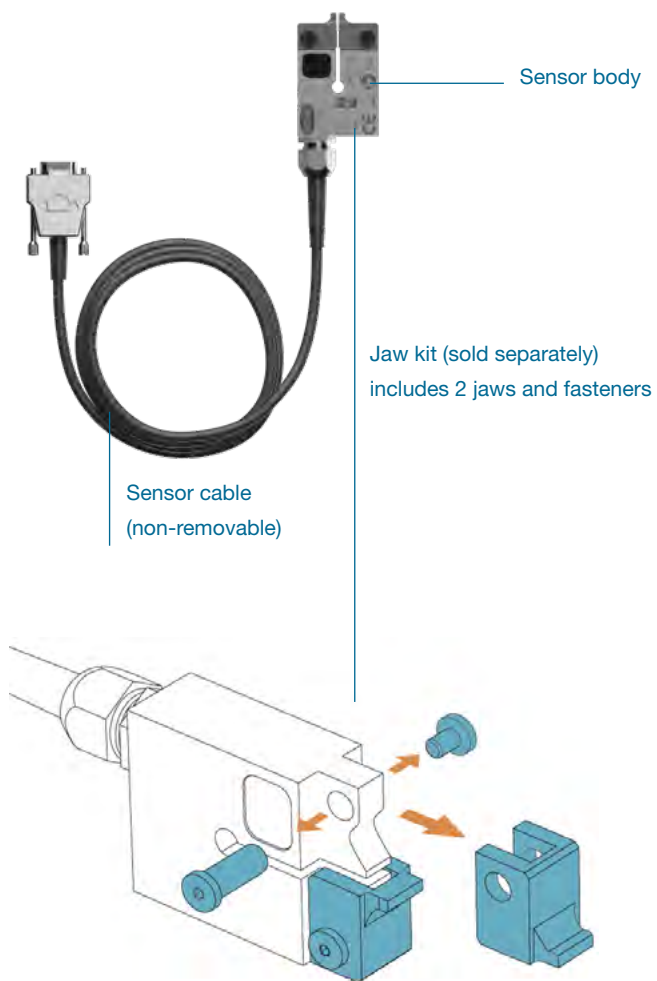

Dimensions

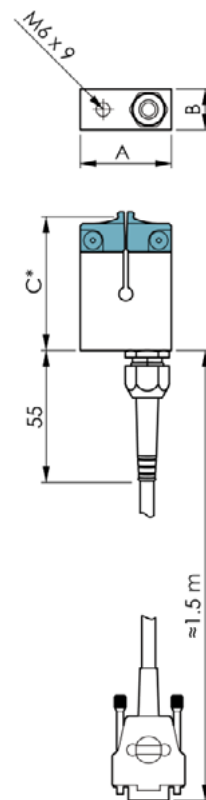

	6 kN Sensor	10 kN Sensor
Length (C*)	59 mm	66.5 mm
Width (A)	40 mm	48 mm
Height (B)	18 mm	22 mm
Weight with cable	350 g	525 g
Sensor cable strain relief length	55 mm	55 mm
Sensor cable strain relief max diameter	9.2 mm	9.2 mm
D-SUB Connector width	32 mm	32 mm
D-SUB Connector height	16 mm	16 mm
Length with connectors	1.559 m	1.5665 m

*consistent for all jaw types

Material

Stainless Steel

Functional critical attributes

	6 kN Closing Force Sensor	10 kN Closing Force Sensor
Sensor type	Strain gauge (DMS) sensor	Strain gauge (DMS) sensor
Measuring range	200-6000 N	200-10 000 N
Operating temperature range	10 °C to 40 °C	10 °C to 40 °C
Calibrated range	1200-6000 N	2000-10 000 N
Altitude max.	2000 m above sea level	2000 m above sea level
Degree of pollution	3 (according to EN 61010-1)	3 (according to EN 61010-1)
Overvoltage category	I (according to EN 61010-1)	I (according to EN 61010-1)
Accuracy	Accurate within ± 11 N below 2000 N, and ± 26 N over the full measuring range.	Accurate within ± 45 N over the measuring range.
Sensor lifecycle	500 000 cycles minimum	500 000 cycles minimum
Product damaging parameters	<ul style="list-style-type: none"> • large fluctuations in ambient temperature • direct sunlight • humidity above 80% and condensation • excessive dust or debris • salty and wet environmental conditions 	

Maintenance attributes

Maintenance cycle

Check the fCAL 1 at least once per shift for externally visible damage and proper function.

Calibration

To maintain the high quality of this measuring instrument, Oetiker recommends that an annual calibration is performed through your nearest Oetiker Service Center.

Measuring device, sensor, or total system can be calibrated. Calibrating the device and sensors independently is recommended to use one Measuring Device with multiple Closing Force Sensors.

Each device, sensor, or system should be re-calibrated after 1 year or 10.000 cycles (whichever happens first).

Maintenance and repair location

Oetiker Service Center

Two-year limited warranty applies. See Oetiker terms and conditions of purchase at Oetiker.com/service for more information

Maintenance and calibration responsibility

The owner of the product

This document has been prepared and provided in good faith without representation or warranty, assurance or undertaking (express or implied) of any kind (including warranties of merchantability, fitness for a particular purpose or non-infringement of intellectual property rights). Neither Oetiker nor any of its officers, employees or agents will accept any responsibility or liability with respect to the adequacy, accuracy, completeness or reasonableness of this document or any other information, notice or documents (whether written or oral) provided or otherwise made available in connection therewith. All and any such responsibility and liability is expressly disclaimed.

Health and safety critical attributes

See instruction manual for detailed safety instructions.

fCAL 1

Calibration Measurement Unit

Product description

Certifications

- EMC compliant
- EU
 - Switzerland
 - Norway
 - United Kingdom
 - USA
 - Canada
 - Mexico
 - Brazil
 - Japan
 - China
 - Thailand
 - South Korea
 - India
 - Turkey
 - Tunisia
 - South Africa
 - Puerto Rico
 - Hong Kong
 - Malaysia
 - Taiwan
 - India
 - Turkey
 - Tunisia
 - South Africa
 - Puerto Rico
 - Hong Kong
 - Malaysia

Maintenance attributes

fCAL 1 spare parts

- 32100022 4x AA NiMH rechargeable batteries
- 32100026 USB-C / USB-C cable
- 32100057 X3 data cable
- 05011983 Hex key for 6 kN sensor
- 05011984 Hex key for 10 kN sensor
- 32100056 6 kN Sensor jaw bolt
- 05011715 6 kN Sensor jaw screw
- 32100079 10 kN Sensor jaw bolt
- 05007854 10 kN Sensor jaw screw
- 08906870 Operating instructions
- 32100017 Battery cover screw
- 32100097 Small cases for one Measuring Device
- 32100098 Small cases for one Closing Force Sensor

General data

Article numbers

6 kN Closing Force Sensor Jaw Kits

- 32100038 10 mm Ear Clamp Jaws for force Calibration
- 32100039 10 mm Ear Clamp Jaws for force and Stroke Calibration
- 32100040 7 mm Ear Clamp Jaws – Force Calibration
- 32100041 7 mm Ear Clamp Jaws – Force and Stroke Calibration
- 32100042 5 mm Ear Clamp Jaws – Force Calibration
- 32100043 5 mm Ear Clamp Jaws – Force and Stroke Calibration
- 32100044 PG 168 Type 3 Jaws – Force Calibration
- 32100045 PG 168 Type 13 Jaws – Force Calibration
- 32100046 PG 168 Type 13 Jaws – Force and Stroke Calibration
- 32100047 PG 192 Jaws – Force Calibration
- 32100048 PG 192 Jaws – Force and Stroke Calibration
- 32100049 PG 168 Type 3 Jaws – Force and Stroke Calibration
- 32100050 PG 292 Jaws – Force and Stroke Calibration
- 32100051 PG 270 Jaws
- 32100052 PG 268 Jaws – Force Calibration
- 32100053 PG 268 Jaws – Force and Stroke Calibration
- 32100054 PG 298 Jaws – Force and Stroke Calibration
- 32100055 PG 292 Jaws – Force Calibration

10 kN Closing Force Sensor Jaw Kits

- 32100087 10 mm Ear Clamp Jaws – Force Calibration
- 32100088 10 mm Ear Clamp Jaws – Force and Stroke Calibration
- 32100083 12.5 mm Ear Clamp Jaws – Force Calibration
- 32100084 12.5 mm Ear Clamp Jaws – Force and Stroke Calibration